

PCAN-MicroMod Digital 1&2

Application-specific PCAN-MicroMod
Motherboard

User Manual v1.10.0



Products taken into account

Product Name	Model	Part number
PCAN-MicroMod Digital 1	Including casing and PCAN-MicroMod	IPEH-002200
PCAN-MicroMod Digital 2	Including casing and PCAN-MicroMod	IPEH-002201

CANopen® and CiA® are registered community trade marks of CAN in Automation e.V.

All other product names mentioned in this document may be the trademarks or registered trademarks of their respective companies. They are not explicitly marked by "™" and "®".

© 2012 PEAK-System Technik GmbH

PEAK-System Technik GmbH
Otto-Roehm-Strasse 69
64293 Darmstadt
Germany

Phone: +49 (0)6151 8173-20
Fax: +49 (0)6151 8173-29

www.peak-system.com
info@peak-system.com

Document version 1.10.0 (2012-05-08)

Contents

1	Introduction	4
1.1	Properties at a Glance	4
1.2	Prerequisites for Operation	5
1.3	Scope of Supply	6
2	Hardware Configuration	7
2.1	Pull-up/Pull-down Circuits for the Digital Inputs	8
3	Operation	10
3.1	Port Assignment	10
3.2	Configuration Program	11
3.2.1	System Prerequisites	11
3.2.2	Installing the Program	12
3.2.3	Creating a Configuration	12
3.2.4	Applicable MicroMod Services	13
3.3	Status LEDs	14
3.4	Several MicroMods on the CAN Bus	14
4	Technical Specifications	16
	Appendix A CE Certificate	18
	Appendix B Dimension Drawing	19

1 Introduction

The motherboards for PCAN-MicroMod provide an application-oriented environment. Typical characteristics of this product group include a wide supply voltage range and the protective circuit for the inputs and outputs. CANopen® firmware is available for all PCAN-MicroMod motherboards.

The motherboards Digital 1 & 2 support general digital requirements.



Note: This manual only refers to the motherboard as base for a PCAN-MicroMod and to the standard firmware. For the PCAN-MicroMod and the configuration program PCAN-MicroMod Configuration, there is separate documentation.

1.1 Properties at a Glance

- Completely configurable using the Windows program PCAN-MicroMod Configuration
- Communication through High-speed CAN (ISO 11898-2)
- Operating voltage 8 to 26 V
- Aluminum profile casing with spring terminal connectors
- Top hat rail mounting option available
- Extended operating temperature range from -40 to +85 °C (-40 to +185 °F)

- └ 8 digital inputs:
 - Pull-up or pull-down circuit selectable (in 3 groups)
 - High state at 5 to 18 V input voltage
 - Schmitt trigger behavior, inverting
 - Low-pass behavior
 - Parallel connection of a frequency input (for each digital input 0 to 3) for alternative use (e.g. fast status changes, countings)
- └ 5 digital outputs:
 - PCAN-MicroMod Digital 1: 4 low-side switches, max. 45 V, 0.35 A
 - PCAN-MicroMod Digital 2: 4 high-side switches, max. 34 V, 1.1 A
 - 1 fast low-side switch, max. 55 V, 0.75 A (“Frequency output”)
 - Short circuit protection
- └ Status LEDs for power supply and digital output

1.2 Prerequisites for Operation

- └ Power supply in the range of 8 to 26 V DC
- └ For creating and transferring configurations: computer with Windows 7/Vista/XP (32-bit or 64-bit) and a CAN interface from the PCAN series

1.3 Scope of Supply

- └ PCAN-MicroMod
- └ PCAN-MicroMod motherboard in casing including mating connectors
- └ PCAN-MicroMod Configuration for Windows
- └ Manual in PDF format

2 Hardware Configuration

You can customize the motherboard by modifying the hardware. The following subsections contain descriptions about possible modifications.

Accessing the Motherboard

In order to carry out the modifications described in the following sections, unscrew the lid of the casing and pull off the MicroMod from the motherboard.



Attention! Electrostatic discharge (ESD) can damage or destroy components on the motherboard or the PCAN-MicroMod. Take precautions to avoid ESD when handling the boards.

Remounting the MicroMod

When you remount the MicroMod, take notice of the white triangular marks on each the motherboard and the MicroMod (upper left corner). These marks must align.

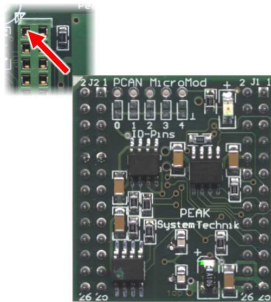







Figure 1: Positioning of the MicroMod

2.1 Pull-up/Pull-down Circuits for the Digital Inputs

At delivery the digital inputs are set to pull-up circuits. You can set them to pull-down circuit in groups. This is done by changing positions of 0-Ohm resistors or solder bridges.

Digital inputs Digital 1	Solder bridge position for	
	Pull-up (+U _b)*	Pull-down (GND)
DIn 0 to DIn 2	R32 (H) 	R35 (L) 
DIn 3 to DIn 5	R33 (H) 	R36 (L) 
DIn 6 and DIn 7	R34 (H) 	R37 (L) 

* Setting at delivery

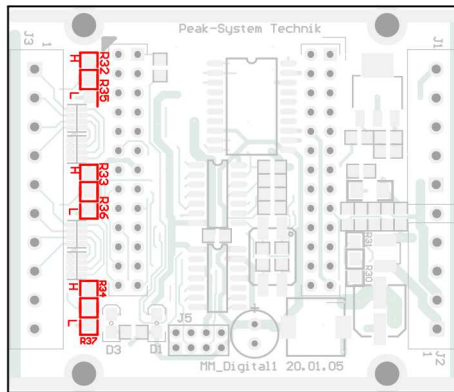







Figure 2: Positions R32/R35, R33/R36, R34/R37 on the Digital 1 motherboard

Digital inputs Digital 2	Solder bridge position for	
	Pull-up (+U _b)*	Pull-down (GND)
DIn 0 to DIn 2	R33 (H) 	R36 (L) 
DIn 3 to DIn 5	R34 (H) 	R37 (L) 
DIn 6 and DIn 7	R35 (H) 	R38 (L) 

* Setting at delivery

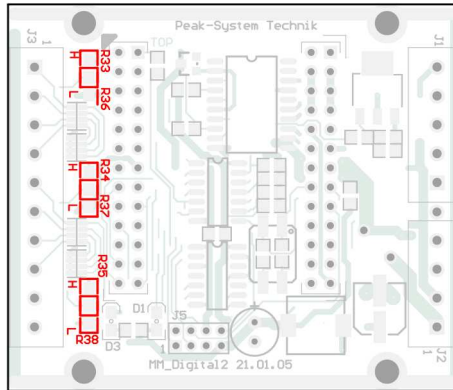

Figure 3: Positions R33/R36, R34/R37, R35/R38 on the Digital 2 motherboard



Attention! Double-check for inadvertently made short circuits after altering the setup of an input group.

3 operation

3.1 Port Assignment

The motherboard has two connectors, J1/2 on the left and J3 on the right. The port assignment is as follows:

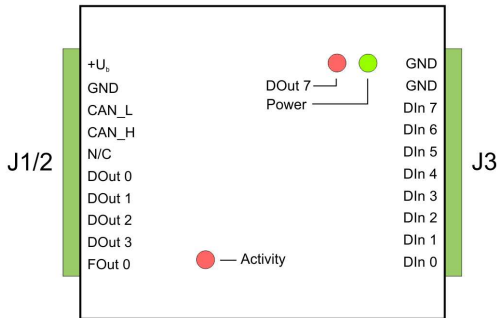

Figure 4: Ports of the motherboards Digital 1 and Digital 2

Port name J1/2	Function
+U _b	Operating voltage 8 - 26 V DC
GND	Digital ground
CAN_L	Differential CAN signal
CAN_H	
N/C	Not connected
DOut 0	Digital output
DOut 1	
DOut 2	
DOut 3	
FOut 0	Frequency output

Port name J3	Function
GND	Digital ground
GND	
DIn 7	Digital input
DIn 6	
DIn 5	
DIn 4	
DIn 3	Digital input, frequency input parallel
DIn 2	
DIn 1	
DIn 0	

3.2 Configuration Program

In order to create and transfer MicroMod configurations, the Windows program PCAN-MicroMod Configuration is used. This section covers basic points about installation and use of the program with the motherboards Digital 1 & 2.

You'll find detailed information about the use of PCAN-MicroMod Configuration in the related documentation which is invoked via the program (e.g. with **F1**).

3.2.1 System Prerequisites

- Windows 7/Vista/XP (32-bit or 64-bit)
- Computer with CAN interface of the PCAN series (for transferring a configuration to the PCAN-MicroMod via CAN)

3.2.2 Installing the Program

Under Windows install the program from the supplied CD. Start the corresponding installation routine by using the CD navigation going to **Tools > PCAN-MicroMod Configuration 2.x.x**.

3.2.3 Creating a Configuration

When you start creating a new configuration in PCAN-MicroMod Configuration, the **Board Type** dialog box appears in order to select the type of the used motherboard. The necessary settings are explained in the following.

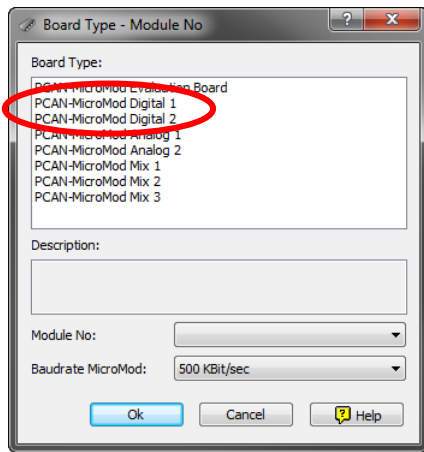

Figure 5: PCAN-MicroMod Configuration: selection of the motherboard Digital 1 or Digital 2

Board Type: PCAN-MicroMod Digital 1, PCAN-MicroMod Digital 2

Select the motherboard that you are using.

Module No: 0

The module number of the MicroMod on the Digital 1 or Digital 2 motherboard is set to 0 at delivery and is relevant if you want to configure more than one MicroMod on the same CAN bus. See also section 3.4 *Several MicroMods on the CAN Bus* on page 14.

Baudrate MicroMod: 500 kbit/s







At delivery the MicroMod is set to a bit rate of 500 kbit/s. A change of this setting will take effect after sending the completed configuration to the MicroMod.



Note: For the first transfer of a configuration to the module it must be integrated in a CAN network with a bit rate of 500 kbit/s.

3.2.4 Applicable MicroMod Services

The motherboard's inputs and outputs are controlled by the services of the MicroMod. The following table shows the assignment of the motherboard functions to the MicroMod services.

Function on motherboard	Port name	Access with MicroMod service(s)
Digital input	DIn 0 ... DIn 7	 Digital Input  Digital Function  Rotary Encoder
Frequency input (parallel to the channels DIn 0 ... DIn 3)		 Frequency Input
Digital output	DOut 0 ... DOut 3	 Digital Output
Frequency output (for higher-frequency status changes)	FOut 0	 PWM and Frequency Output
LED DOut 7	DOut 7	 Digital Output

3.3 Status LEDs

The motherboard including the MicroMod has three LEDs with the following status indications:

LED	Indication
Power (green)	Power is applied.
DOut 7 (red)	Is linked to the digital output DO 7 of the MicroMod and can be configured freely.
Activity (red)	Status of the PCAN-MicroMod:
blinking at 1 Hz	normal operation
blinking at 2 Hz	invalid or no configuration
blinking at 5 Hz	configuration mode
continuously on	internal MicroMod error

3.4 Several MicroMods on the CAN Bus

If you want to use several MicroMods on the same CAN bus and want to configure them, each one needs its own module number. That way the MicroMods are distinguishable for the program PCAN-MicroMod Configuration.

The module number is set on the MicroMod by solder jumpers and lies in the range of 0 to 31. At **delivery** each MicroMod has the **module number 0**.

During normal operation of the PCAN-MicroMod, the module number has no effect on the CAN communication.

For setting the solder jumpers on the MicroMod unscrew the top of the casing and remove the MicroMod from the motherboard. Please find further information about the assignment of module numbers in the separate user manual for the PCAN-MicroMod.



Attention! Electrostatic discharge (ESD) can damage or destroy components on the motherboard or the PCAN-MicroMod. Take precautions to avoid ESD when handling the boards.

Remounting the MicroMod

When you remount the MicroMod, take notice of the white triangular marks on each the motherboard and the MicroMod (upper left corner). These marks must align.

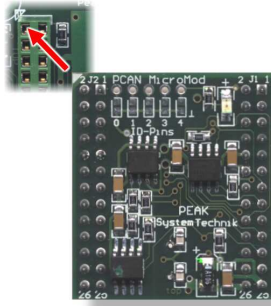

Figure 6: Positioning of the MicroMod

4 Technical specifications

	Digital 1	Digital 2
Power supply		
Operating voltage +U _b	8 - 26 V DC (±5 %)	
Current consumption	max. 200 mA typ. 35 mA at 12 V w/o load	max. 200 mA (w/o output driver)
Ripple (5 V)	< 50 mV (+U _b = 12 V, 200 mA load)	
Reverse-polarity protection	extant; can get ineffective by the wiring with other CAN nodes (danger of destruction of electronic components)	
Digital inputs		
Count	8	
Switching thresholds	UIH = 4 V; UIL = 3 V, contact or logic level	
Input impedance	2.7 kΩ	
Open input	Pull-up, optionally pull-down (in groups)	
Overvoltage protection	extant	
Low-pass	f _g = 7 kHz	
Special feature	Frequency inputs of the PCAN-MicroMod parallel (only DI 0 to DI 3)	
Digital outputs		
Count	5	
Type	Low-side	DOut: High-side FOut: Low-side
Voltage proof	DOut: < 45 V FOut: < 55 V	DOut: < 43 V FOut: < 55 V
Output current	DOut x: 0.35 A FOut: 0.75 A (constant current, all outputs active)	DOut x: 1.1 A FOut: 0.75 A
Short circuit protection	extant; short-circuit currents: DOut x: 0.5 A FOut: 1.2 A	DOut: 4 A FOut: 1.2 A

CAN

Transmission standard	High-speed CAN ISO 11898-2, typ. 500 kbit/s, setup with PCAN-MicroMod Configuration (Windows software)
Termination	none
CAN ID reserved for configuration transfer	0x7E7
Module number at delivery (for configuration transfer)	0

Peculiarity Interference Immunity

Tests	compliant to IEC 61000 and DIN EN 61326
Surge	± 500 V (specification industrial sector: ± 1 kV) ¹
Line-conducted HF compatibility	10 V _{eff} (specification: 3 V _{eff})

Environment

Operating temperature	-40 - +85 °C (-40 - +185 °F)
Temperature for storage and transport	-40 - +100 °C (-40 - +212 °F)
Relative humidity	15 - 90 %, not condensing
Ingress protection (IEC 60529)	IP20
EMC	DIN EN 61326-1:2008-06 EC directive 2004/108/EG

Measures

Casing size (incl. connectors)	55 x 68 x 24 mm See also dimension drawing in Appendix B on page 19
Weight	107 g

¹ This specification could only be fulfilled with ± 500 V due to the available space. Therefore the motherboard should be used with a local power supply.

Appendix A CE Certificate

PCAN-MicroMod Digital 1/2 IPEH-002200/01 – EC Declaration of Conformity
PEAK-System Technik GmbH



Notes on the CE Symbol

The following applies to the "PCAN-MicroMod Digital 1/2" product with the item number(s) IPEH-002200/01.

EC Directive This product fulfills the requirements of EC directive 2004/108/EG on "Electromagnetic Compatibility" and is designed for the following fields of application as for the CE marking:

Electromagnetic Immunity/Emission
DIN EN 61326-1, publication date 2008-06
Electrical equipment for measurement, control and laboratory use – EMC requirements – Part 1: General requirements (IEC 61326-1:2005);
German version EN 61326-1:2006-10

Declarations of Conformity In accordance with the above mentioned EU directives, the EC declarations of conformity and the associated documentation are held at the disposal of the competent authorities at the address below:

PEAK-System Technik GmbH
Mr. Wilhelm
Otto-Roehm-Strasse 69
64293 Darmstadt
Germany

Phone: +49 (0)6151 8173-20
Fax: +49 (0)6151 8173-29
E-mail: info@peak-system.com

A handwritten signature in black ink, appearing to be "U. Wilhelm".

Signed this 3rd day of April 2012

Appendix B Dimension Drawing

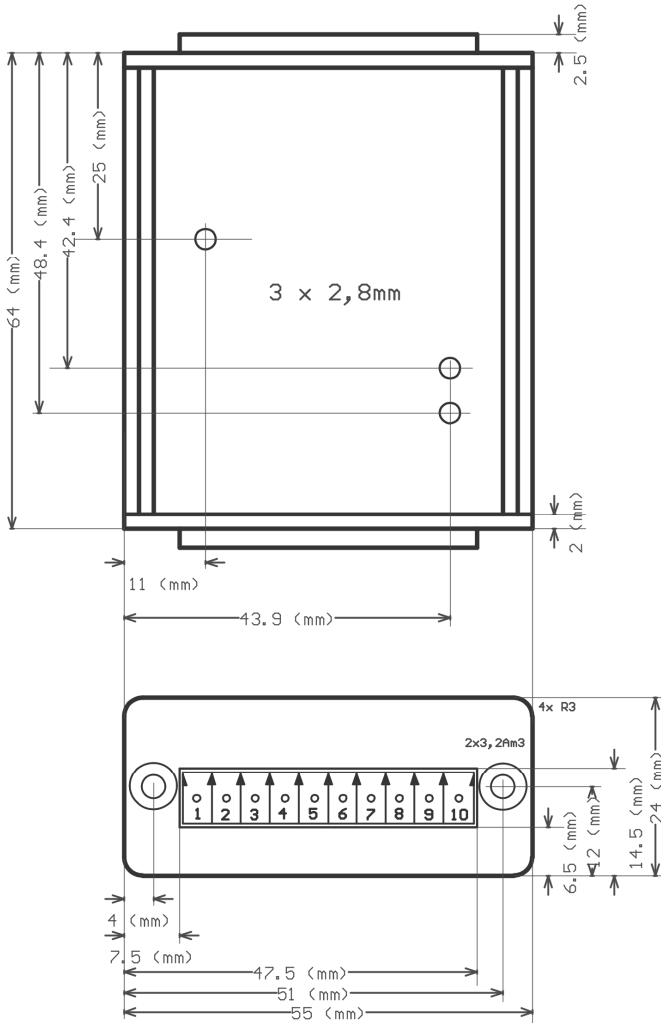

Figure 7: Top view and view of front side with connector. The figure does not show the actual size of the product.