

Torque Sensor

Series 3000 and Series 4000



- Contactless torque sensor
- Measurement range from 0 to 2000Nm bi-directional
- Accuracy classes
 - Series 3000: 0,2
 - Series 4000: 0,1
- High dynamic loads
- Maintenance free handling
- Torque measurement up to 10.000 rpm
- Integrated signal conditioning
- Optional angle sensor
- Optional sensor outputs PWM, 4...20mA, RS232
- Temperature range from -30°C to +85°C

1. Short description

This non-contact sensor measures the torque transferred by the shaft bi-directionally independent from the rotational speed. The sensor package includes the signal processing electronics and a connecting cable, there are no further amplifiers required. Due to the non-contact measurement principle the sensor is maintenance free and suitable for harsh environments.

2. Model Series 3000 / Series 4000

Model Series 3000 / Series 4000		Nominal-Torque	Max. overload	Rotational Speed
Shaft	Unit	Bi-directional (+/-)	Bi-directional (+/-)	[rpm]
15 mm	[Nm]	50	150	10.000
	[ft-lb]	37	111	
15 mm	[Nm]	100	300	10.000
	[ft-lb]	74	221	
25 mm	[Nm]	250	750	8.000
	[ft-lb]	184	553	
25 mm	[Nm]	500	1500	8.000
	[ft-lb]	369	1106	
40 mm	[Nm]	1000	3000	5.000
	[ft-lb]	738	2213	
40 mm	[Nm]	2000	6000	5.000
	[ft-lb]	1475	4425	

3. Technical data

Nr.	Accuracy class ¹	Unit	Series 3000		Series 4000			
			0,2		0,1			
		Unit	Value					
1	Linearity deviation incl. hysteresis	%ME*	<± 0,2		<± 0,1			
2	Circular modulation	%ME*	<± 0,2		<± 0,1			
3	Repeatability	%ME*	<± 0,5		<± 0,5			
Output signal in general		Unit	Value					
4	Frequency range, -3dB point, Bessel characteristic	Hz	0...2500					
5	Analog signal	V	0... 10					
6	Signal at torque = Null ²	V	≈ 5					
7	Signal at positive nominal torque	V	≈ 9					
8	Signal at negative nominal torque	V	≈ 1					
9	Calibration parameter	mV/Nm	≈4000mV / Measurement range					
10	Output resistance	Ω	62					
Effect of temperature		Unit	Value					
11	Nullpointdrift by Temperature	%/10K	<0,2					
12	Nullpointdrift by Temperature at nominal (rated) temperature range ³	%/10K	<0,5					
Power supply		Unit	Value					
13	Power supply	VDC	11...28					
14	Maximal power input	mA	150					
15	Start-up peak	mA						
16	Max. permissible power peak	VDC	30					
General Information		Unit	Value					
17	Degree of protection following EN 60529	IP	50 (64 if required)					
18	Reference temperature	°C	+15...+35					
19	Service temperature range	°C	-30...+85					
20	Storage temperature range	°C	-30...+100					
Nominal rated torque M (bi-directional)		Nm	50	100	250	500	1000	2000
21	Weight	g	1280		2030		5800	
22	Moment of inertia round shaft	kg*mm ²	5,9		59,5		626	

%ME: related to a full scale measurement range

- 1) The accuracy class implies that taken separately the linearity deviation as well as the rotational signal uniformity are either lower than or equal to the value of the accuracy class. The accuracy class is not to be identified with the classification following DIN 51309 or EA-10/14.
- 2) Zero point can be set by button pressing at 5V.
- 3) The factor of transmission declines linearly when temperature increases up to maximum 0,5% / 10K, due to the reduction of the elasticity module.

EMV		Unit	Value		
Interference immunity following DIN EN 61000-6					
	Electromagnetic field				
23	Housing	V/m	June 2011		
24	Magnetic field	A/m	June 2011		
25	Burst	kV	June 2011		
26	ESD	kV	June 2011		
EMV		Unit	Value		
transmission Interference following EN55011; EM55022; EN55014					
27	Voltage transmission interference	-	June 2011		
28	Performance transmission interference	-	June 2011		
29	Field strength transmission interference	-	June 2011		
Load limits ⁴		Unit	Value		
30	Maximum measured torque	%	110		
31	Maximum torque, related to nominal (rated) torque	%	300		
32	Ultimate torque	%	500		
33	Maximum load of key stone (Application factor 1,5)	%	180	200	200
Impact resistance		Unit	Value		
Immunity test level following DIN EN 60068-2-7					
34	Number		June 2011		
35	Duration		June 2011		
36	Acceleration (Halbsinus)		June 2011		
Vibration resistance		Unit	Value		
Immunity test level following DIN EN 60086-2-6					
37	Frequency		June 2011		
38	Duration		June 2011		
39	Acceleration (Amplitude)		June 2011		

- 4) Due to the contact free measurement principle, the torque sensor is as far as possible insensitive to bending and lateral forces. There is no need of adjustment couplings.

4. Versions i.e. ordering possibilities

Series 3000 Accuracy 0,2%					
Series 4000 Accuracy 0,1%					
		Option 1: Measurement range			
	5	0	Nm		
	1	0	0	Nm	
	2	5	0	Nm	
	5	0	0	Nm	
	1	0	0	0	Nm
	2	0	0	0	Nm
		Angle sensor			
	0	without angle sensor			
	1	with angle sensor 360 P/U (optical)			
	2	with angle sensor 8P/U (magnetical) IP64, -40°C			
		Output signal additionally to analog voltage			
	A	Standard model with voltage output			
	S	Voltage output 4-20mA			
	P	PWM output			
	F	Frequency output 20-100kHz			
		Shaft ending			
	0	Standard model with stone key			
	1	Square shaft ending			
		Couplings system with customised endings			
	N	Without couplings system			
	K	With couplings system			
		Protection class			
	0	IP50			
	1	IP64 (possible only with magnetic angle sensor)			

5. Optionally available

5.1 Optional signal outputs

In addition to the analog signal it is also possible to deliver the Series 3000 und Series 4000 with another optional output signal.

Frequency output		
Description	Unit	
Basic frequency	kHz	60
Measurement range	kHz	20...100
Calibration parameter	kHz/Nm	40/Measurement range

Voltage output		
Description	Unit	
Signal at torque = Null	mA	12
Measurement range	mA	4...20
Calibration parameter	mA/Nm	8/Measurement range

PWM-signal output		
Description	Unit	
Carrier frequency	Hz	980
Signal at torque = Null	%	50
Measurement range	%	10...90
Error indication	%	95
Calibration parameter	%/Nm	40/Measurement range

5.2 Angular sensor

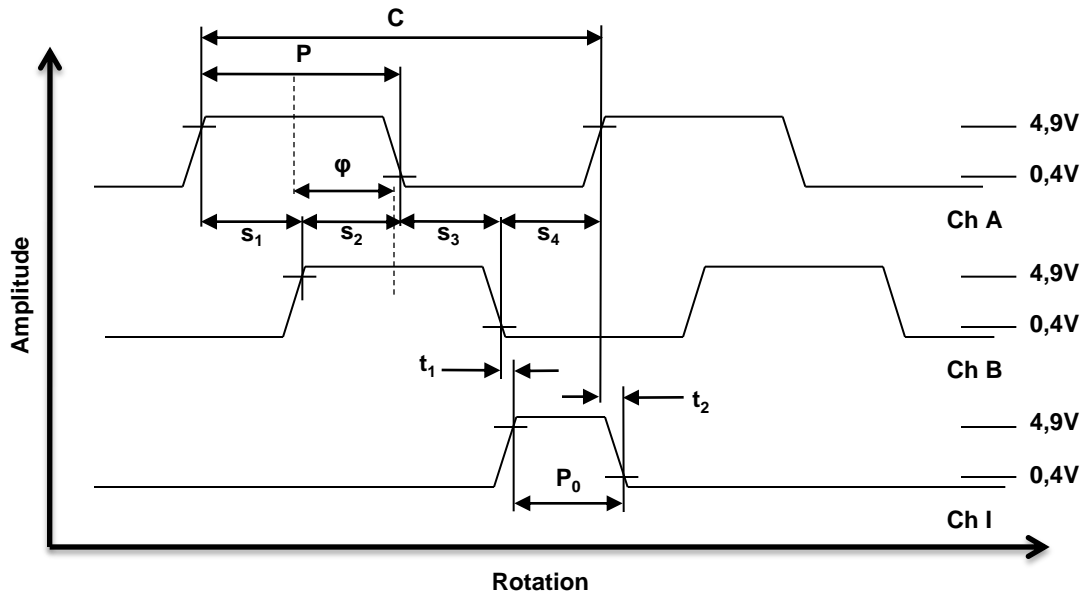

		Symbol	Unit	Typ.	Min.	Max.
1	Impulse per Rotation (optical)	n		360		
2	Periodical error	ΔC	Degree	$0,8 \times 10^{-2}$		$4,2 \times 10^{-2}$
3	Pulswidth error	ΔP	Degree	$1,9 \times 10^{-2}$		$8,3 \times 10^{-2}$
4	Statuswidth error	Δs_x	Degree	$1,4 \times 10^{-2}$		$8,3 \times 10^{-2}$
5	Phase error	$\Delta \varphi$	Degree	$0,6 \times 10^{-2}$		$4,2 \times 10^{-2}$
6	Pulswidth index	P_0	Degree	0,25	0,17	0,33
7	Ch I increases if Ch B or Ch A reduces	t_1	ns	100	10	1000
8	Ch I increases if Ch A or Ch B increases	t_2	ns	300	10	1000
9	Increase-time flanks	t_r	ns	180		
10	Decrease-time flanks	t_f	ns	50		

1) Degree relates to rotation

Angular sensor with 8 Impulses per rotation and magnetic system is also available.

		Unit	Typ.	Min.	Max.
1	Pulses per revolution	-	8		
2	High Level	V		4,9	
3	Low Level	V			0,4

6. Dimensions

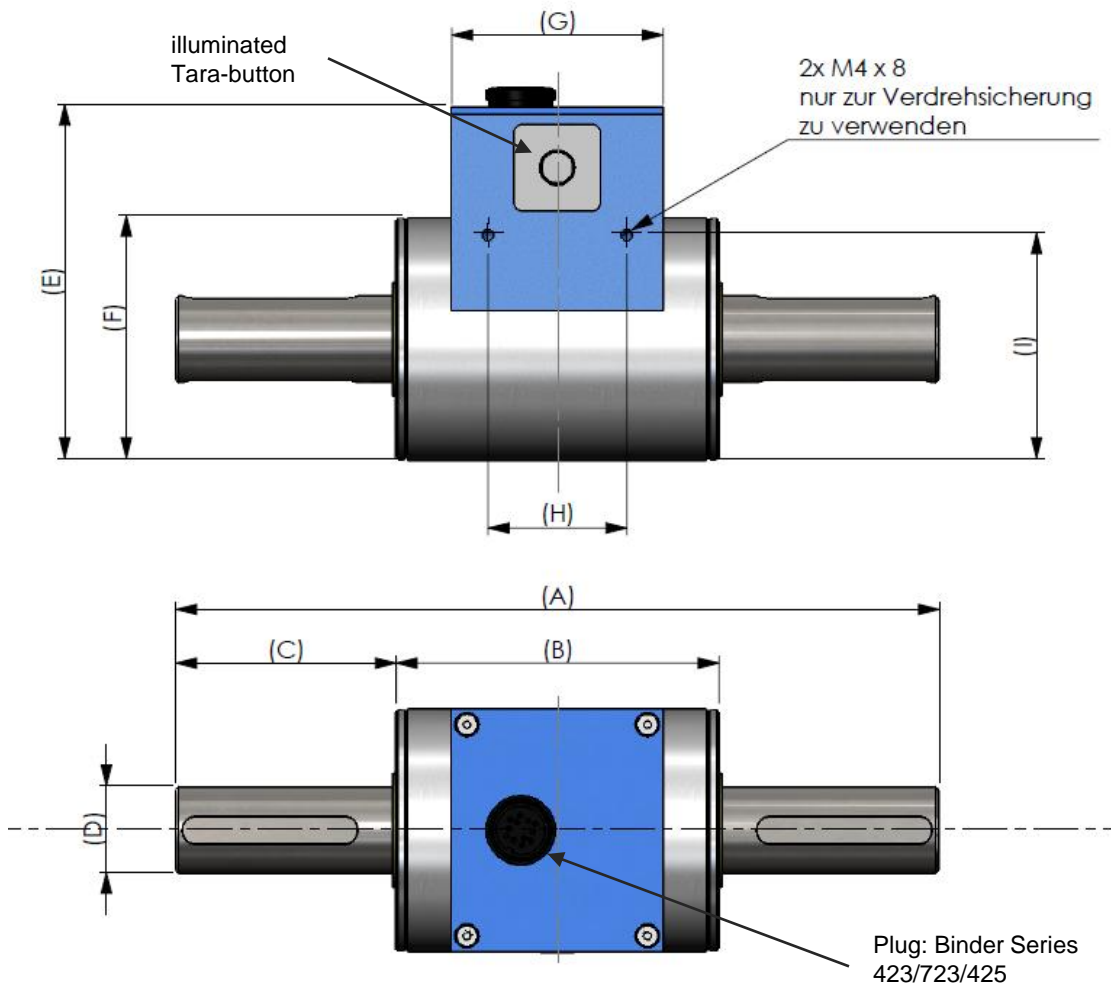

Dimensions (in mm):									
	A	B	C	D	E	F	G	H	I
50 Nm	160	93	49,5	15g6	92,5	60	61	40	55
100 Nm	160	93	49,5	15g6	92,5	60	61	40	55
250 Nm	220	93	63,5	25g6	102,5	70	61	40	65
500 Nm	220	93	63,5	25g6	102,5	70	61	40	65
1000 Nm	350	130	135	40g6	122,5	90	80	60	85
2000 Nm	350	130	135	40g6	122,5	90	80	60	85

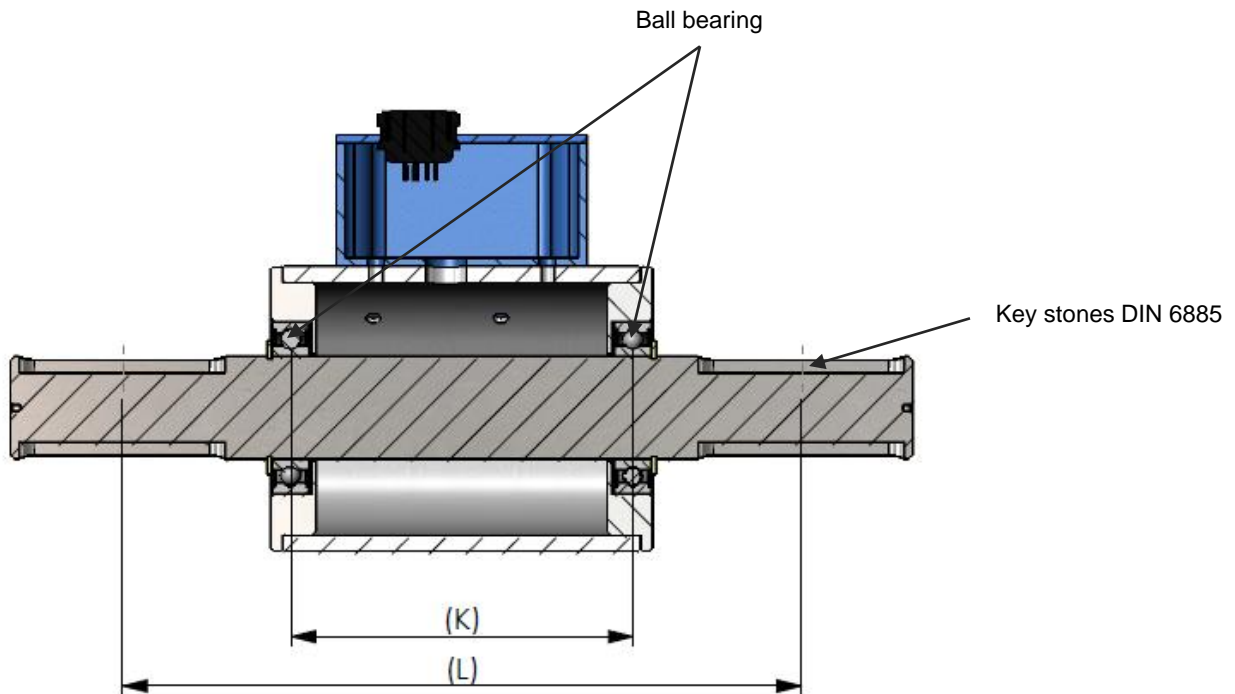

Ball bearing							
Shaft ending	Distance K [mm]	Description	Outer diameter [mm]	Inner diameter [mm]	Max. rotation of bearing [U/min]	Load rating [kN]	
						Dyn. C	Stat. C ₀
Ø 15mm	82,0	E2.6202-2Z/C3	35	15	25.000	7,8	3,75
Ø 25mm	83,4	61905-2RZ	42	25	18.000	7,02	4,3
Ø 40 mm	114,6	6008-2RZ	68	40	11.000	17,8	11,6

Dimensions of Key stone slot (mm)				Key stone DIN 6885			Key stone-position
Shaftending	Width	Depth	Length	Height	Length	Number	Distance L
Ø 15mm	5N9	3	25,5	5	25	1	130,5
Ø 25mm	8N9	4	50,5	7	50	2	165,5
Ø 40 mm	12N9	5	80,5	8	80	2	252,0

At high reverse loads the torque is to be transmitted through a form lock with the shaft.

7. Connecting plan

Pin assignment at Sensor.
Diagram: Top view

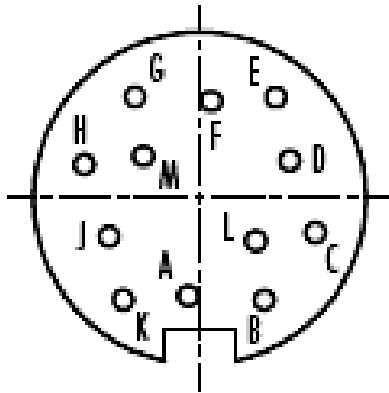

Typ – Binder Series 423/723/425			
Unit number: 09-0132-90-12			
Colourcoding after DIN 47100			
Pin	Colour	Description	Value
A	White	Supply voltage V_{CC}	11V...28V
B	Braun	Mass GND	
C	Green	Analog Out	0V...10V
D	Yellow	Analog GND	
E	Gray	PWM / Frequency / 4-20mA	
F	Pink	Angle Ch-A / Magnetic Angle Sensor	0V...5V
G	Blue	Angle Ch-Z	0V...5V
H	Red	Angle Ch-B	0V...5V
I	Black	-	
K	Violet	Only for internal use	Do not connect
L	Grey-Pink	Only for internal use	Do not connect
M	Red-Blue	Digital GND	

Connection example

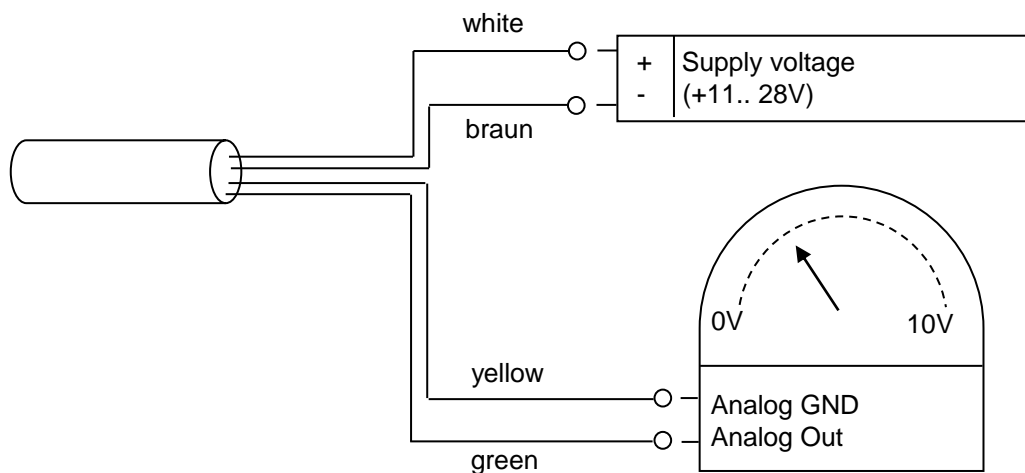

8. User's Manual

8.1 Installation

The torque sensor is to be used in the industrial area. (e.g. test bench).

8.2 Package contents

The torque sensor system contains one sensor with signal receipt and processing integrated in the housing, a connection cable with soldered plug connector and user's manual.

8.3 Mounting and Dismounting

Make sure to install the sensor with the measurement shaft exactly aligned with the connecting shaft. The key stone – adapter / square endings of the connecting shafts are to be attached to the key stone – adapter / square endings of the sensor without extra effort. The Sensor is not force resistant; external axial and radial forces should not affect the housing during connecting. If avoiding of bending and radial forces is not possible make sure to check calculations of the bearing. The approved bearing forces are listed in Chapter 6 – Dimensions. The lateral M4-screw threads serve for protection of the sensor from distortion. Cable should not be longer than 3m. In case of use of a cable other than NCTE-cable or a cable with unsuitable length the performance of the sensor may be affected.

Dismounting is only allowed when no torque is applied on the measuring shaft.

8.4 Adjustment

If required the zero point of the output signal (5 V) can be adjusted by pressing a button. Ex works the sensor is set at 5 V.

8.5 Interface description

Mechanical interface:

The key stone connectors on both endings of the measurement shaft are intended for torque transmission

Electrical interface:

A 12-pin flange receptacle for voltage supply and signal output is fixed on the surface of the housing.

(For pin-allocation check 7. Connecting plan).

8.6 Use (in regular operation, optimization)

Optimal measurement parameters may be achieved when sensor is applied in accordance with the specified nominal (rated) torque and only short-period operation with maximum allowed rotation. By compliance with the allowed operational values the sensor operates interference- and maintenance-free.

8.7 Irregular operation, measurements against interference

The presence of external electromagnetic or magnetic fields can lead to irregular measurement results.

The mechanical overload of the sensor (e.g. exceeding of maximum allowed torque or stronger vibrations) may cause damaging of sensor and incorrect signal output. In such cases the sensor is to be reset (see 8.4 justification). If this does not eliminate the interference, do not open the device and contact NCTE instead.

8.8 Putting into operation

After mounting of sensor do not forget the following:

- Switch on power supply and control voltage (power peaks at sensor must be avoided, before connecting to the sensor devices must be suitably tested).
- Plug in sensor to power supply (with enclosed cable).
- Receipt of output signal with high impedance (z.B. A/D-Wandler, Oszilloskop, PC- Messkarte).
- Receipt of output signal in mechanically unloaded state.

Tara function and error indication:

Series 3000/Series 4000 contains at electronic housing a led button which is to press in order to reset the sensor at zero. The illumination of the button serves as functional illumination as well as error indicator.

Functional illumination:

LED off: no power supply or sensor is damaged
LED on: Sensor is operable.

Error indicator:

Attention LED flashing. The sensor is inoperable.

Flashing of LED can have more possible causes. Various causes are signaled through a flash code. After each flash code the LED makes a short stop, afterwards the flash code starts over.

2x flashing: Magnet field sensors defect.
4x flashing: Electronics defect.

8.9 Service / Maintenance

Service-contact:

Tel.: ++49 89 66 56 19 0
Fax: ++49 89 66 56 19 29

8.10 Disposal

For purposes of disposal please send device back to NCTEngineering GmbH.

8.11 Handling and Transport

By handling, storage and transport do not forget to keep sensor protected from various magnetic and electromagnetic fields which exceed the maximum allowed range of electromagnetic tolerance listed in Chapter 3 Technical data.

8.12 Precautions

- Do not open sensor under any given circumstances.
- The shaftprotection rings on both shaft endings are not to be loosened.
- The mounting nut of the plug as well as the locking screws are not to be loosened or tightened.
- Apply exclusively safely isolated power supply from system voltage
- In regard to electric and mechanical loading please follow the specifications given in the sensor-specific capacity shield and table in Chapter 3.
- Do not expose the sensor to any electric or magnetic fields which exceed the maximum allowed range of electromagnetic tolerance (Chapter 3 Technical data)
- Do not use sensor as support bearing. The existing fixing possibilities serve exclusively for protection of housing from distortion.

9. Calibration and Accuracy class

The exact sensor data are given in the enclosed manufacturing calibration certificate. Apart from information on sensor type this certificate also includes the exact calibration data of the sensor. Each sensor has its own calibration characteristic value which is listed in the calibration certificate as well as on the label of the sensor. Beside calibration characteristic value the calibration certificate also shows the accuracy of each sensor. The accuracy class of an NCTE torque sensor means that the largest single deviation of all values represented as percentage is either smaller from or equals the value which is listed in the accuracy class.

Calibration characteristic value:

The calibration characteristic value shows how much the output signal changes per rotation. It usually makes no difference whether the rotation is directed to the left or to the right.

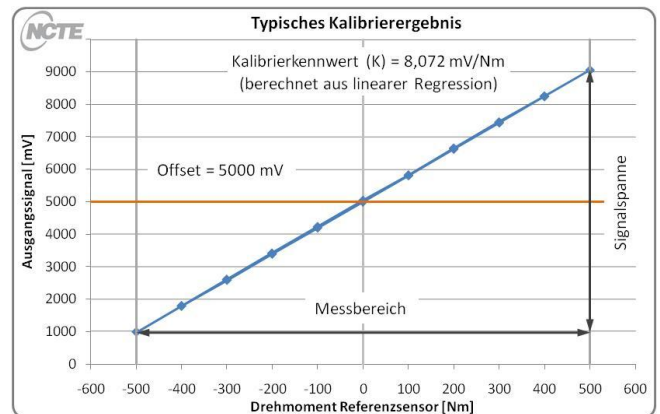

Hysteresis:

Expresses in percent the biggest difference of a torque level between upwards and downwards branch.

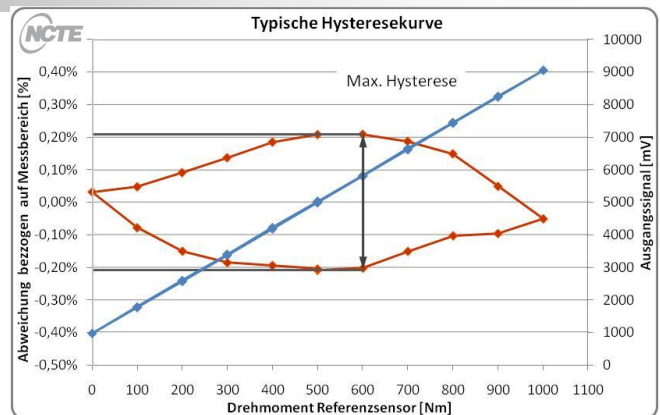

Rotational Signal Uniformity (RSU):

RSU is a signal variation created during 360° rotation of a shaft, without application of torque. The modulation is the difference between minimal and maximal value during single rotation. RSU is generated by smaller inhomogeneities in the magnetic field and depends mostly on the configuration of the Sensorshaft.

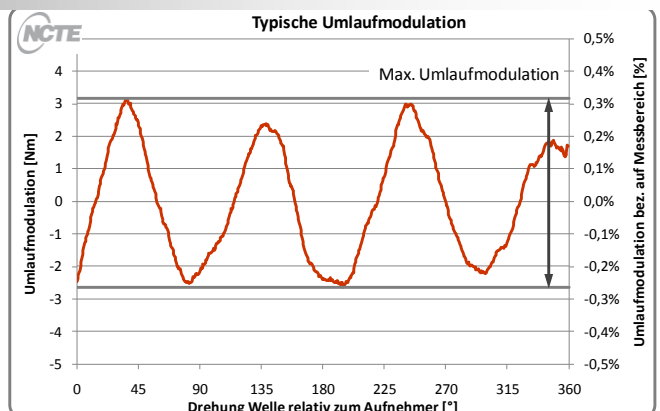

10. Contact Us

NCTEngineering GmbH

Contact:

Erlenhof-Park
Inselkammerstr. 10
82008 Unterhaching
Deutschland
Tel.:+ 49 89 665619-0
Fax:+ 49 89 665619-29
Email: info@ncte.de

Sales:
Joachim Heckler
Tel.:+ 49 89 665619-46
Email: Joachim.Heckler@ncte.de