

F²MC-8FX FAMILY
8-BIT MICROCONTROLLER
MB95F430 SERIES

**INDUCTION HEATER
HARDWARE**

USER MANUAL



Revision History

Version	Date	Updated by	Modifications
1.0.	2010-04-06	Folix	First draft
1.1	2010-08-11	Folix	Modified: 1. System Feature; 2. MCU Pin Assignment; 3. IGBT Feature; 4. Power Module; 5. IGBT Driver Module; 6. Pad Driver Module; 7. Main Board SCH;
1.2	2010-9-10	Terry	Update operation description

This manual contains 22 pages.

1. The products described in this manual and the specifications thereof may be changed without prior notice. To obtain up-to-date information and/or specifications, contact your Fujitsu sales representative or Fujitsu authorized dealer.
2. Fujitsu will not be liable for infringement of copyright, industrial property right, or other rights of a third party caused by the use of information or drawings described in this manual.
3. The contents of this manual may not be transferred or copied without the express permission of Fujitsu.
4. The products contained in this document are not intended for use with equipment which require extremely high reliability such as aerospace equipment, undersea repeaters, nuclear control systems or medical equipment for life support.
5. Some of the products described in this manual may be strategic materials (or special technology) as defined by the Foreign Exchange and Foreign Trade Control Law. In such cases, the products or portions theory must not be exported without permission as defined under the law.

© 2010 Fujitsu Semiconductor Design (Chengdu) Co., Ltd.

Contents

REVISION HISTORY	2
CONTENTS	3
1 INTRODUCTION	4
2 SYSTEM FEATURES	5
3 SYSTEM INTRODUCE	6
3.1 Hardware Block Diagram	6
3.2 MCU Resource Usage	6
3.3 MCU Pin Assignment	7
3.4 IGBT Features	8
4 SYSTEM HARDWARE	9
4.1 System Connect Diagram	9
4.2 Front Board	10
4.3 Main Board	11
5 MODULE DESCRIPTION	12
5.1 Power Module	12
5.2 IGBT Driver Module	13
5.3 Pad Driver Module	14
6 SYSTEM OPERATION	15
6.1 Key & Led Definition	15
7 DEBUG AND PROGRAMMING	17
7.1 Debug Environment and Tools	17
7.2 Hardware Setup	17
7.3 MCU Programming	17
8 ADDITIONAL INFORMATION	18
9 APPENDIX	19
9.1 Front Board SCH and BOM-List	19
9.2 Main Board SCH and BOM-List	20
9.3 List of Figures	22

1 Introduction

This document introduces how to use the electromagnetic oven hardware.

The hardware includes two PCB boards (main board and front board), a fan and a pad.

2 System Features

- Power Control
- Fan Control
- Fan Delay Off
- Buzz Control
- Led Display
- Keyboard
- Kettle Detect
- Kettle Empty Detect
- Timing Power Off (3Hours)
- Constant Power Heating
- Constant Temperature Heating
- IGBT Temp Detect
- Plate Temp Detect
- IGBT Temp Higher Protect (120°C)
- Plate Temp Higher Protect (300°C)
- Kettle Empty Protect (300°C)
- Sensor Open/Short Detection
- Over Current Protect (18A)
- Over Voltage Protect (260V)
- Lower Voltage Protect (150V)
- Surge Protect (1000V)
- No Operation for 2 Hours, auto turn off, if no timer

In the system design, we will use some feedback signals to protect system or calculate watt. The protect signal includes over current, over voltage, surge voltage and kettle detect. If anyone of them appears, the system must stop work. If the IGBT temperature is raised over 60°C, the fan must turn on. If the IGBT temperature is raised over 120°C, the system must stop work. If the kettle is empty, the plate temp will rise. If the temp is raised up to 300°C, the system must stop work.

3 System Introduce

3.1 Hardware Block Diagram

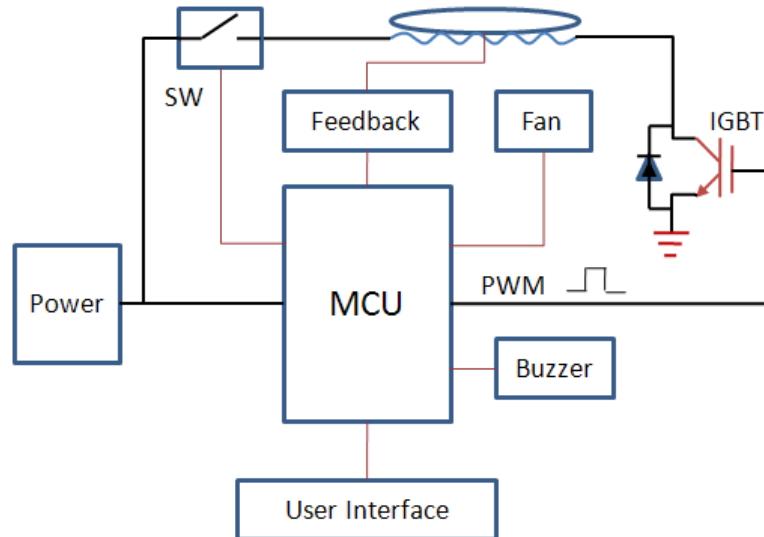

Figure 3-1: Hardware Block Diagram

The electromagnetic eddy current heating is our system theory. We use the PWM to control the IGBT to generate the heating eddy current. The fan is use to cool the IGBT. The feedback signal is used to protect the system and calculate power.

3.2 MCU Resource Usage

MB95F434K Resource Usage			
No.	Resource	Usage Info	Remark
1	VCC	5.0V	
2	ROM		
3	RAM		
4	OSC Clock	16.25MHz	
5	CPU Clock	8.125MHz	
6	GPIO	6 Pins	LED COM(5),Start
7	INTxx	1 Pins (Internal)	Pad osc
8	8/16Bit PPG(Timer)	1 Pins(PPG)	
9	ANxx	4 Pins	
10	UART0	LED Display	
11	Debug	1 Pins	
12	Watchdog Timer	Monitor System	
13	16Bit Timer0	Keyboard Sample	
14	16Bit Timer1	10MS Timer	Protect,Error

3.3 MCU Pin Assignment

No.	Name	Define	Note	Remark
1	PG2/PPG0/X1A/OUT1	sub oscillator	sub oscillator	
2	PG1/TRG0/ADTG/X0A/BZ/OUT0	sub oscillator	sub oscillator	
3	VCC	VCC	Vcc	
4	C	C	C	
5	P60/OPAMP_P	OPAMP_P	Current by Resistor	
6	P61/OPAMP_N	OPAMP_N		
7	P62/OPAMP_O	P62	LED COM2	
8	P12/EC0/UI/DBG	P12/DBG	Debug	
9	P00/INT00/AN00	P00	Start IGBT	
10	P01/INT01/AN01/BZ	BZ	Buzzer	
11	P02/INT02/AN02/UCK/TRG0	UCK	Serial Clock	
12	P03/INT03/AN03/UO/PPG0	UO	Serial Data	
13	P04/INT04/AN04/UI/HCLK1	AN04	AC voltage Measuring	
14	P05/INT05/AN05/TO0/HCLK2	AN05	AC Current Measuring	
15	P06/INT06/AN06/TO1	AN06	Temperature for IGBT	
16	P07/INT07/AN07/EC0	AN07	Temperature for plate	
17	P70/CMP0_O/OUT0/TRG0	P70	LED COM4	
18	P71/CMP0_P	CMP0_P	PAD-L+ Input	
19	P72/CMP0_N	CMP0_N	PAD-L- Input	
20	P73/CMP1_O/OUT1/PPG0	PPG0	PPG-IGBT	
21	P74/CMP1_P	CMP1_P	OverCurrent Input	Reference
22	P75/CMP1_N	CMP1_n	OverCurrent Input	Compare
23	P76/CMP2_O/UCK	P76	LED COM3	
24	P63/CMP2_P	CMP2_P	OverVoltage Input	Reference
25	P64/CMP2_N	CMP2_N	OverVoltage Input	Compare
26	P65/CMP3_O/UO	P65	LED COM0	
27	P66/CMP3_P	CMP3_P	Surge Reference Input	
28	P67/CMP3_N	CMP3_N	Surge Compare Input	
29	PF2/RSTX	PF2	Reset	
30	PF0/X0	X0	oscillator	
31	PF1/X1	X1	oscillator	
32	VSS	VSS	Vss	

3.4 IGBT Features

Symbol	Parameter	Test Conditions	Min.	Typ.	Max.	Units
Off Characteristics						
I_{CES}	Collector Cut-Off Current	$V_{CE} = V_{CES}, V_{GE} = 0V$	–	–	3	mA
I_{GES}	G-E Leakage Current	$V_{GE} = V_{GES}, V_{CE} = 0V$	–	–	± 250	nA
On Characteristics						
$V_{GE(th)}$	G-E Threshold Voltage	$I_C = 25mA, V_{CE} = V_{GE}$	3.5	5.5	7.5	V
$V_{CE(sat)}$	Collector to Emitter Saturation Voltage	$I_C = 25A, V_{GE} = 15V$	–	2.0	2.5	V
		$I_C = 25A, V_{GE} = 15V, T_C = 125^\circ C$	–	2.15	–	V
		$I_C = 50A, V_{GE} = 15V$	–	2.65	–	V
Dynamic Characteristics						
C_{ies}	Input Capacitance	$V_{CE} = 30V, V_{GE} = 0V, f = 1MHz$	–	3700	–	pF
C_{oes}	Output Capacitance		–	130	–	pF
C_{res}	Reverse Transfer Capacitance		–	80	–	pF
Switching Characteristics						
$t_{d(on)}$	Turn-On Delay Time	$V_{CC} = 600V, I_C = 25A, R_G = 10\Omega, V_{GE} = 15V, \text{Inductive Load}, T_C = 25^\circ C$	–	50	–	ns
t_r	Rise Time		–	60	90	ns
$t_{d(off)}$	Turn-Off Delay Time		–	190	–	ns
t_f	Fall Time		–	100	180	ns
E_{on}	Turn-On Switching Loss		–	4.1	6.2	mJ
E_{off}	Turn-Off Switching Loss		–	0.96	1.5	mJ
E_{ts}	Total Switching Loss		–	5.06	7.7	mJ
$t_{d(on)}$	Turn-On Delay Time	$V_{CC} = 600V, I_C = 25A, R_G = 10\Omega, V_{GE} = 15V, \text{Inductive Load}, T_C = 125^\circ C$	–	50	–	ns
t_r	Rise Time		–	60	–	ns
$t_{d(off)}$	Turn-Off Delay Time		–	200	–	ns
t_f	Fall Time		–	154	–	ns
E_{on}	Turn-On Switching Loss		–	4.3	6.9	mJ
E_{off}	Turn-Off Switching Loss		–	1.5	2.4	mJ
E_{ts}	Total Switching Loss		–	5.8	9.3	mJ
Q_g	Total Gate Charge	$V_{CE} = 600V, I_C = 25A, V_{GE} = 15V$	–	200	300	nC
Q_{ge}	Gate-Emitter Charge		–	15	23	nC
Q_{gc}	Gate-Collector Charge		–	100	150	nC

4 System Hardware

4.1 System Connect Diagram

The whole system includes pad, fan, main board and front board. They are connected as below.

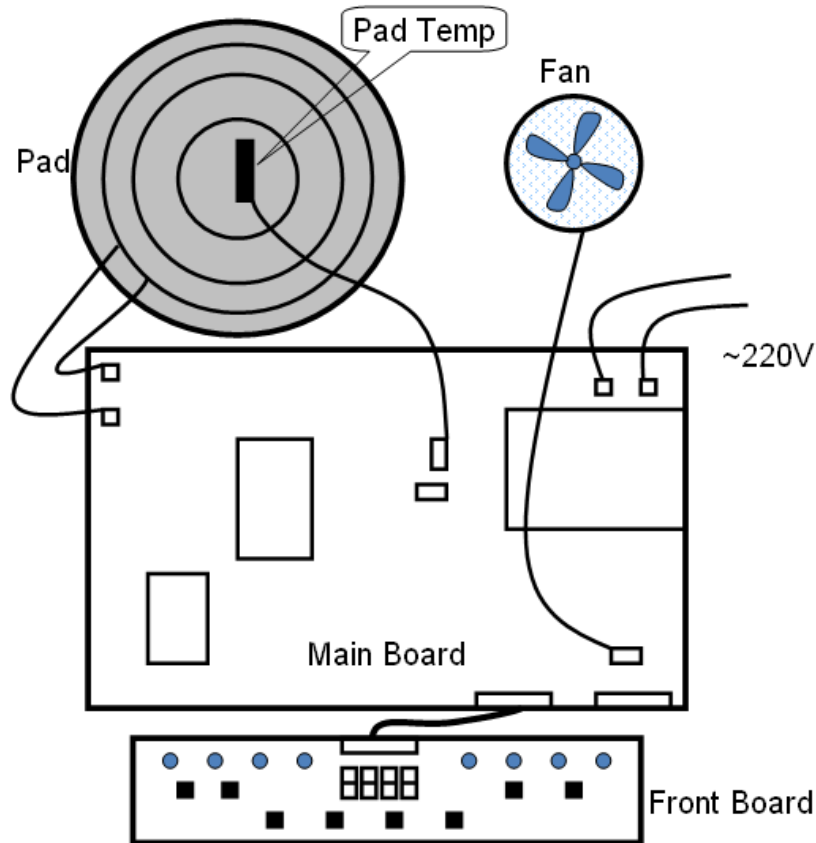

Figure 4-1: System Connection Diagram

Connecting Order:

- Pad to main board
- Pad temp to main board
- Fan to main board
- Front board to main board

4.2 Front Board

Figure 4-2 is the front board image. It is made up of eight LEDs, a 4-bit digital LED and eight buttons.

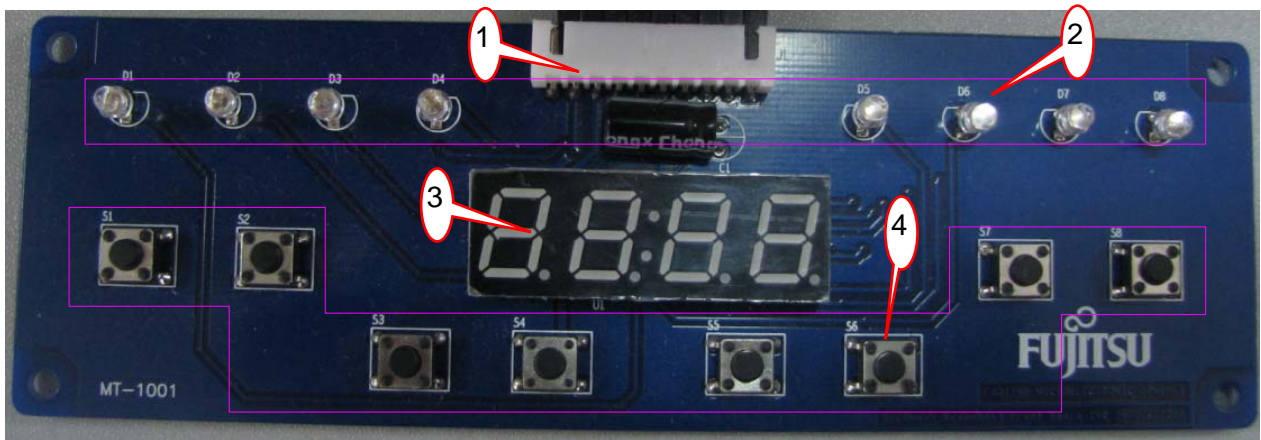

Figure 4-2: Front Board

1. Connector, connect to main board.
2. Eight LEDs, to display some statuses.
3. 4-bit digital LED, to display power and time.
4. Eight buttons, to control the system.

4.3 Main Board

Figure 4-3 is the main board image. It is made up of power module, mcu control module and IGBT driver module.

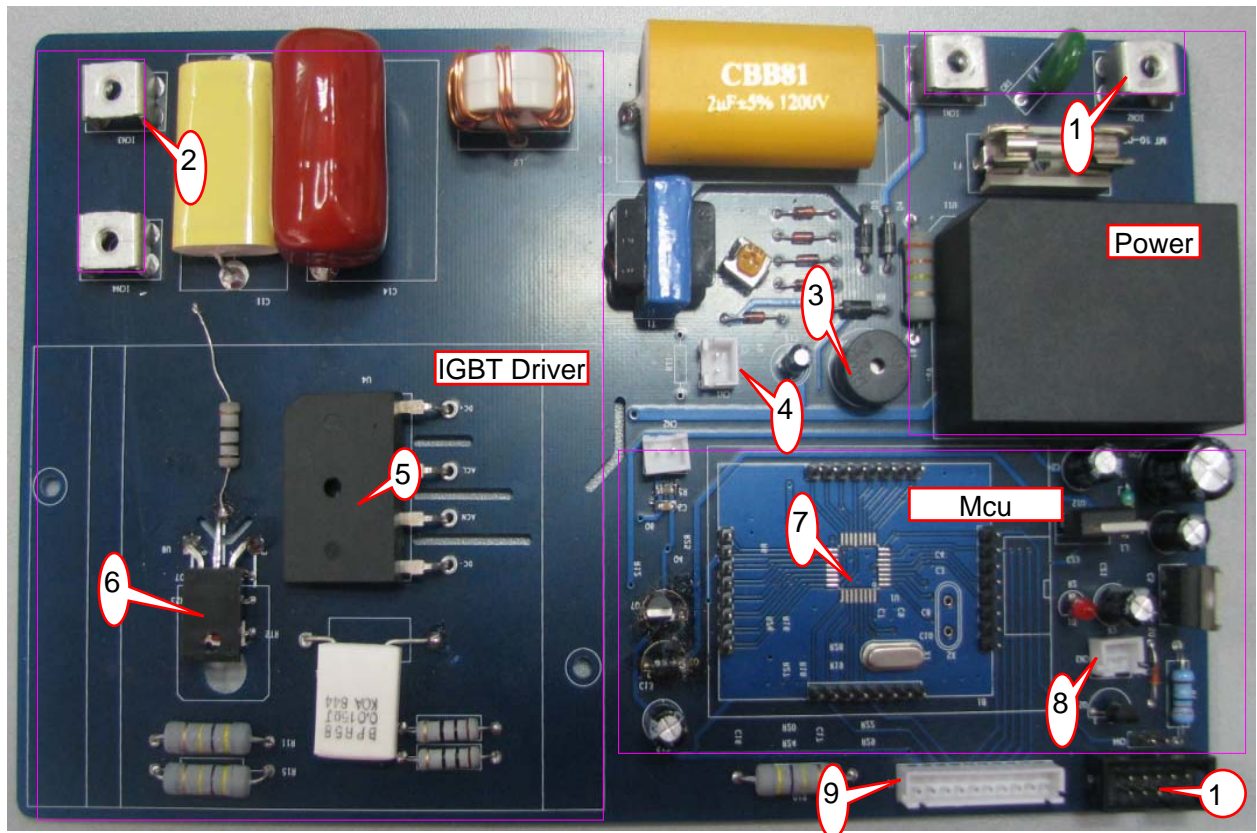
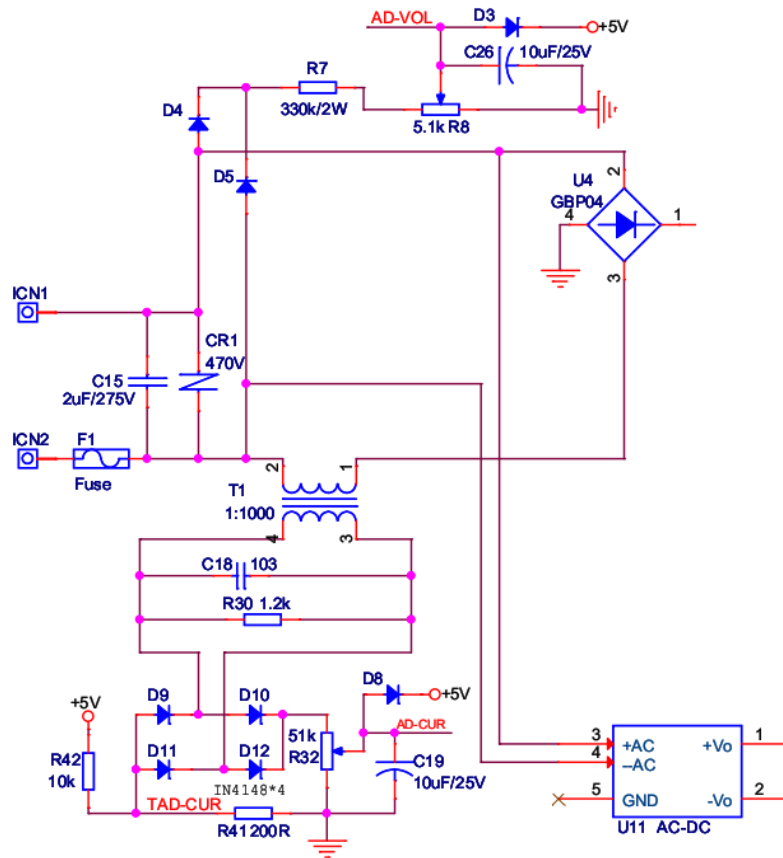

Figure 4-3: Main Board

1. 220VAC, to supply power.
2. Pad Connector, to connect the pad.
3. Buzzer, to note some status.
4. Pad temp connector, to test the pad temperature.
5. IGBT power, to supply power to the IGBT.
6. IGBT, is the IGBT chip.
7. MCU, to control the system.
8. Fan connector, to control the fan.
9. Front connector, to connect the front board.
10. Debug connector, to connect the simulator.

5 Module Description

5.1 Power Module



The 220V is connected by “ICN1” and “ICN2”. The 220V is rectified by “U4”, and supplied to the pad. The “U11” is a 15V power module. It supplies power to the MCU and IGBT driver.

5.2 IGBT Driver Module

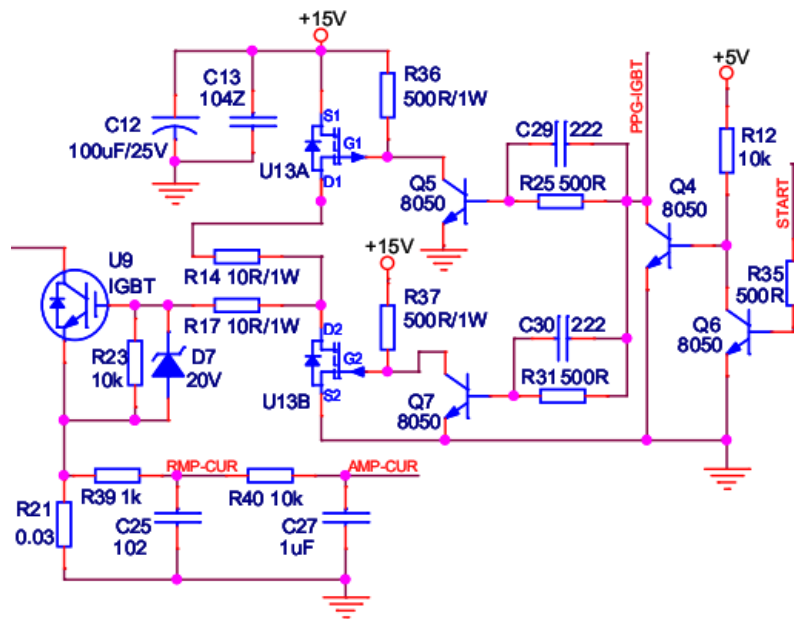

The “START” is the system enable signal. When it is high, the system is enabled, or else disabled.

The “PPG-IGBT” is the IGBT drive signal. When it is high, the IGBT is opened, or else closed. The duty of the “PPG-IGBT” is to decide the pad heating power.

5.3 Pad Driver Module

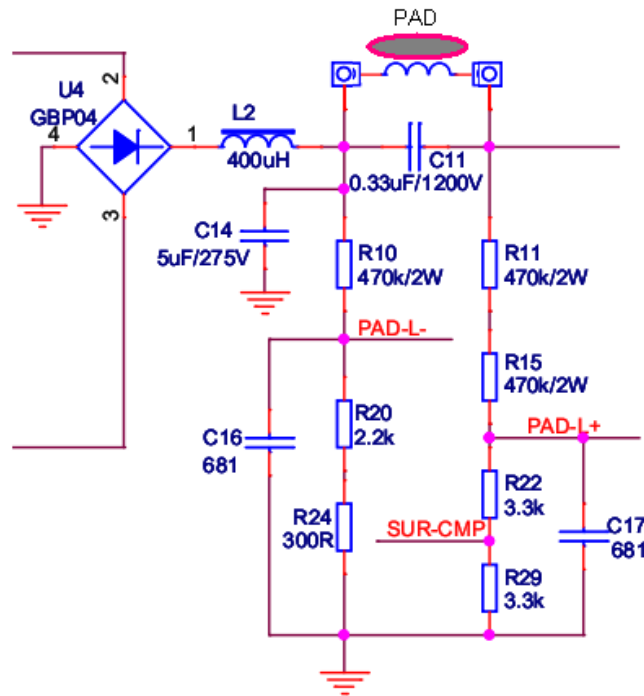

When the IGBT (U9) is opened, the current flows over the “PAD”. The “PAD” is a coil, so it will save the power. The current direction is from left to right. Once the IGBT is closed, because the “PAD” is a coil, the current direction is still from left to right. Because there is a C11, so it and the “PAD” are made an oscillation loop, and the power will be saved in the C11. When the system is working, if there is a cooker on the “PAD” coil, the cooker will be heated.

6 System Operation

6.1 Key & Led Definition

The system key buttons and LEDs are defined as below.

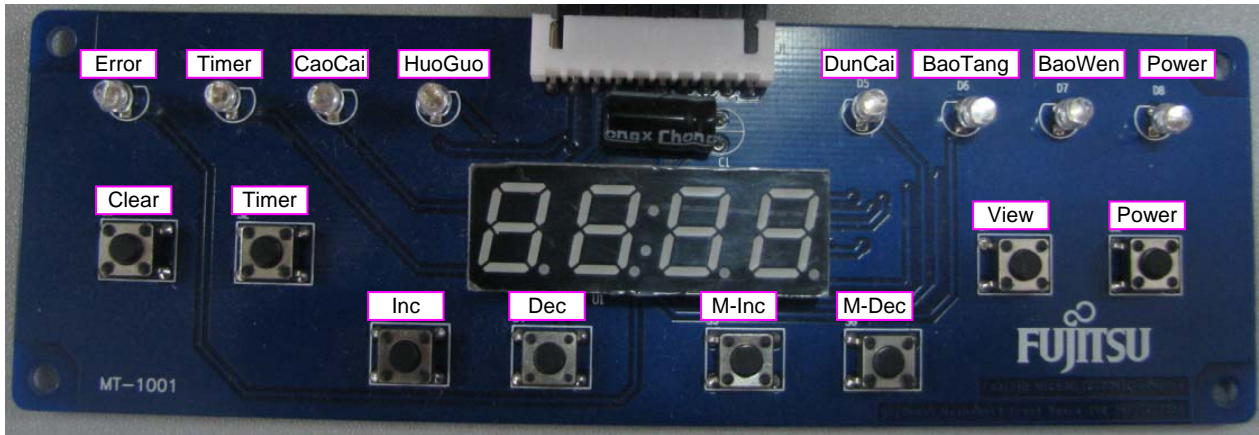

➤ Key Definitions

- Clear-----Clear the timer.
- Timer-----Set the timer.
- Inc-----Power increase.
- Dec-----Power decrease.
- M-Inc-----Mode increase.
- M-Dec-----Mode decrease.
- View-----Change the display, power or timer.
- Power-----Turn on or turn off the device.

➤ Led Definitions

- Error-----Error display.
- Timer-----Timer display.
- CaoCai-----Mode display.
- HuoGuo-----Mode display.
- DunCai-----Mode display.
- BaoTang-----Mode display.
- BaoWen-----Mode display.
- Power-----Power display.

➤

➤ Error Code

Error Code	Description	Notes
0xE0	Power under voltage	
0xE1	Power over voltage	
0xE2	Power over current	
0xE3	Main sensor over 300°C	
0xE4	Main sensor break circuit	
0xE5	Main sensor short circuit	
0xE6	Main sensor temp not change	
0xE7	IGBT temp over 120°C	
0xE8	IGBT sensor break circuit	
0xE9	IGBT sensor short circuit	
0xF0	Kettle is empty	
0xF1		

6.2. Operation Description

- Turn On/Off

When we have connect the power, the “Power” led will light. We can push the “Power” button to turn on the device, and the “Power” led will start wink. At anything, we can push the “Power” button to turn off the device.

- Mode Change

When we turn on the device, the system is in standby. We must push the “M-Inc” or “M-Dec” to start the system. The system has six work modes. You can push the “M-Inc” and “M-Dec” to change the work mode.

- Power Change

In normal, you can use the “Inc” or “Dec” button to change the power, and the range is from 200W to 2100W. When you change the power, the display will automatically change also.

- Timer Set

At first, we push the “Timer”, the system will enter timer setting mode. We can push the “Inc” or “Dec” to change the timer time. When we push the “Timer” again, the timer will be set and started, and the “Timer” led will wink. If we want stop the timer, we must push the “Clear”.

- Display Change

If you push the “View”, you will change the display information between power and time.

7 Debug and Programming

7.1 Debug Environment and Tools

Name	Description	Manufacturer	Notes
Windows XP Pro	PC OS	Microsoft	SP2
Softune V3	Software Developing IDE	Fujitsu	For FFMC-8L
MB95F434K Emulator	MCU Emulator	Fujitsu	---

7.2 Hardware Setup

The basic hardware connection is as below:

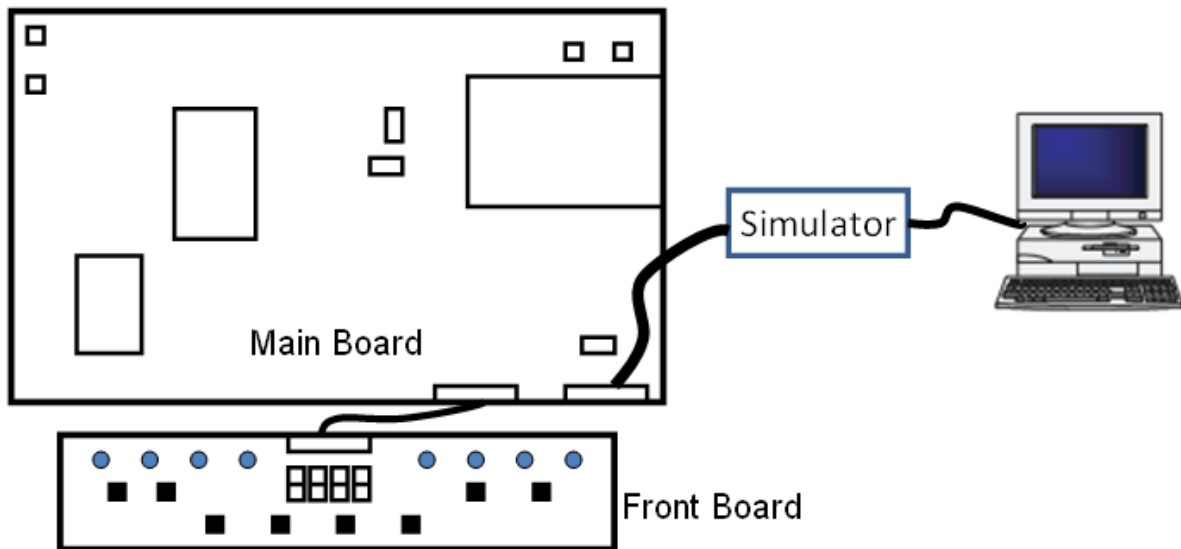

7.3 MCU Programming

We can programme the MCU by the simulator. The basic hardware connection is shown in "7.2 Hardware Setup".

8 Additional Information

For more Information on FUJITSU semiconductor products, visit the following websites:

English version address:

http://www.fujitsu.com/cn/fsp/services/mcu/mb95/application_notes.html

Chinese version address:

http://www.fujitsu.com/cn/fss/services/mcu/mb95/application_notes.html

9 Appendix

9.1 Front Board SCH and BOM-List

➤ Front Board SCH

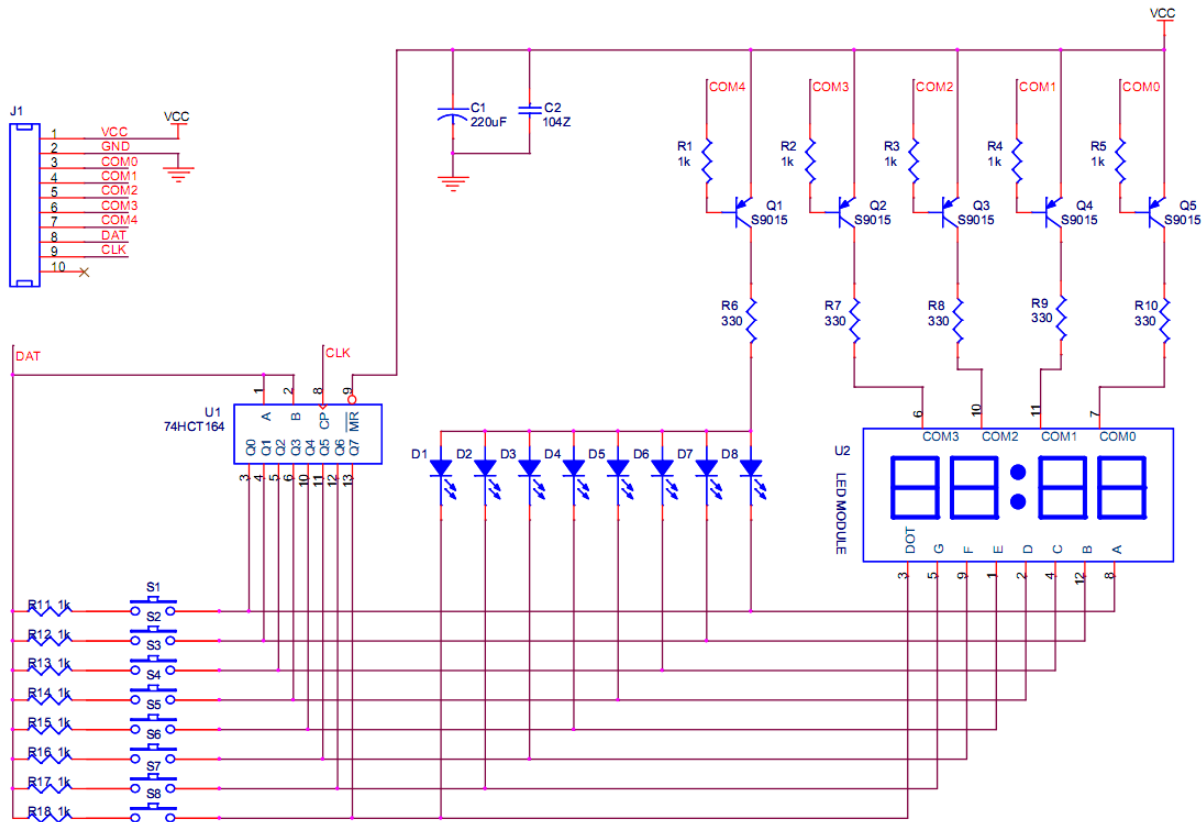

Front Board BOM-List

Front Part List					
Index	Reference	Value	Footprint	Quantity	Description
1	C1	220uF	CAP100V25	1	
2	C2	104Z	C0805	1	
3	D1 D2 D3 D4 D5 D6 D7 D8	IN6264/T0	LED	8	
4	J1	CONN 10	CON10-90	1	
5	Q1 Q2 Q3 Q4 Q5	S9015	SOT-23-PNP	5	
6	R1 R2 R3 R4 R5 R11 R12 R13 R14 R15 R16 R17 R18	1k	R0805	13	
7	R6 R7 R8 R9 R10	330	R0805	5	
8	S1 S2 S3 S4 S5 S6 S7 S8	Switch	KEY	8	
9	U1	74HCT164	SOIC14	1	
10	U2	LED MODULE	LEDM	1	

9.2 Main Board SCH and BOM-List

➤ Main Board SCH

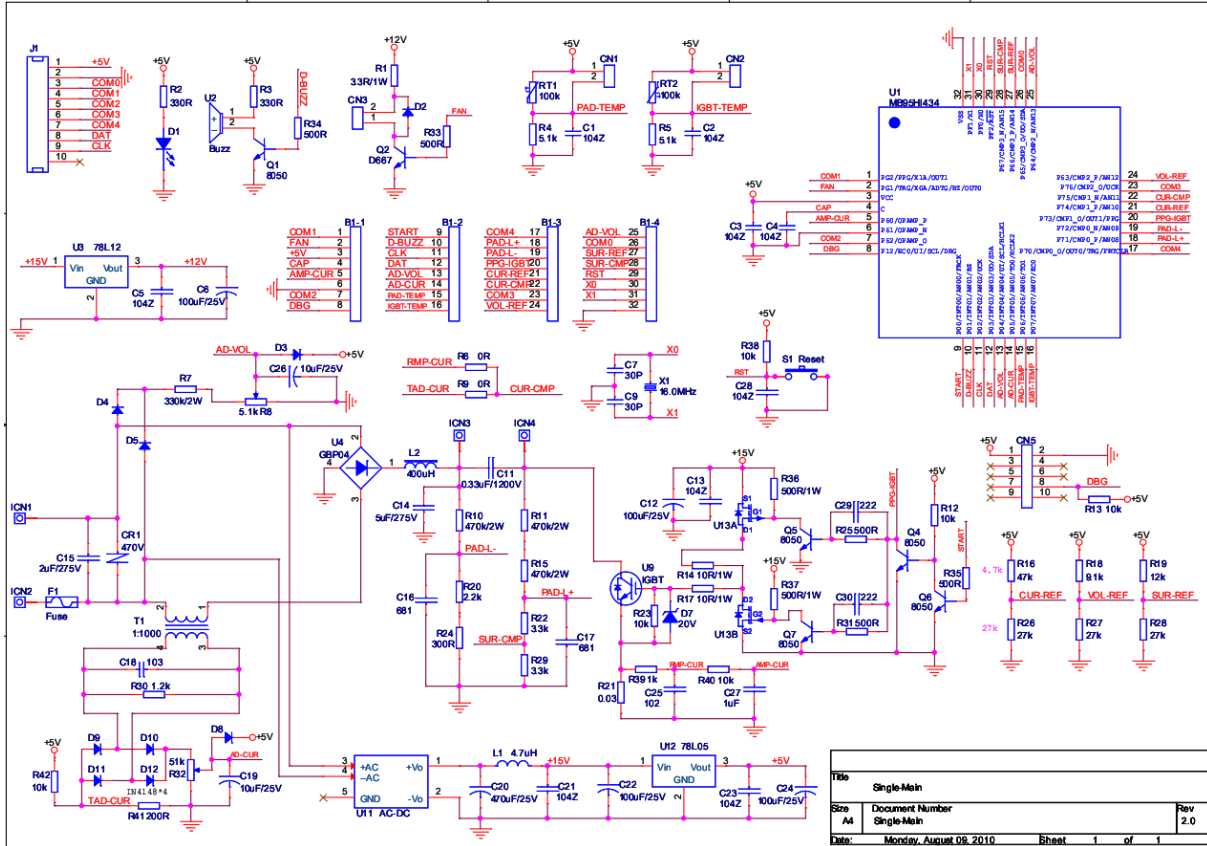

➤ Main Board BOM-List

Main Part List					
Index	Reference	Value	Footprint	Quantity	Description
1	B1	BM-330H	BGM-330H	1	
2	C1 C2 C3 C4 C5 C13 C21 C23	104Z	C0805	8	
3	C6 C12 C22 C24	100uF/25V	CAP100V25	4	
4	C7 C8 C9 C10	30P	C0805	4	
5	C11	0.33uF/1200V	HVCAPD33	1	
6	C14	5uF/275V	HVCAP5U	1	
7	C15	2uF/275V	HVCAP2U	1	
8	C16	681	C0805	1	
9	C17	221	C0805	1	
10	C18	103	C0805	1	
11	C19	2.2uF/25V	CAP2D2V25	1	
12	C20	470uF/25V	CAP470V25	1	
13	CN1 CN2 CN3	CON2_1	CON2_1	3	
14	CN4	JMP2_1	JMP2_1	1	
15	CN5	JMP5_2	JMP5_2	1	

16	CR1	470V	RV	1	
17	D1	Power	LED	1	
18	D2 D8 D9 D10 D11 D12	DI4148	DI4007	6	
19	D3 D4 D5	DI4007	DI4007	3	
20	D7	20V	DI4007	1	
21	F1	Fuse	FUSE-90	1	
22	ICN1 ICN2 ICN3 ICN4	PCN4	PCN4	4	
23	J1	CON10_1	CON10_1	1	
24	L1	4.7uH	R_6_2_10	1	
25	L2	400uH	L-400-90	1	
26	Q1 Q4 Q5 Q6 Q8	8050	SOT-23-8050	5	
27	Q2	D667	TO-92-D667	1	
28	Q3	S8550	TO-92-8550	1	
29	Q7	S8050	TO-92-8050	1	
30	R1	3.3R/1W	R_11_4_16	1	
31	R2 R3	330R	R0805	2	
32	R4 R5 R8	5.1k	R0805	3	
33	R6 R9	0R	R0805	2	
34	R7	330k/2W	R_15_5_22	1	
35	R10 R11 R15	470k/2W	R_15_5_22	3	
36	R12 R13 R25 R36 R37	10k	R0805	5	
37	R14 R17	10R/0.5W	R_11_4_16	2	
38	R16 R29	3.3k	R0805	2	
39	R18 R20	4.7k	R0805	2	
40	R19	6.8k	R0805	1	
41	R21	0.01	R_PWR	1	
42	R22	9.1k	R0805	1	
43	R23	10k	R_6_2_10	1	
44	R24	300R	R0805	1	
45	R26 R27 R28	27k	R0805	3	
46	R30	1.2k	R0805	1	
47	R31	500R	R_V	1	
48	R32	51k	R0805	1	
49	R33 R34 R35	1k	R0805	3	
50	RT1	100k	R_6_2_10	1	
51	RT2	50k	R_6_2_10	1	
52	T1	1:1000	TRANSFER_CUR	1	
53	U1	MB95HI434	LQFP-32	1	
54	U2	Buzz	BUZZER	1	
55	U3	78L12	TO-220	1	
56	U4	GBP04	Rectifier-90	1	

57	U9	IGBT	TO-247-90	1	
58	U11	AC-DC	PWR Module	1	
59	U12	78L05	TO-220	1	
60	X1	16.0MHz	CRYSTAL	1	
61	X2	32.768KHz	CRYSTAL	1	

9.3 List of Figures

Figure 3-1: Hardware Block Diagram.....	6
Figure 4-1: System Connection Diagram.....	9
Figure 4-2: Front Board.....	10
Figure 4-3: Main Board	11