

# Installation Manual



Electric Air Conditioner  
Sizes 024-060

PA12NA

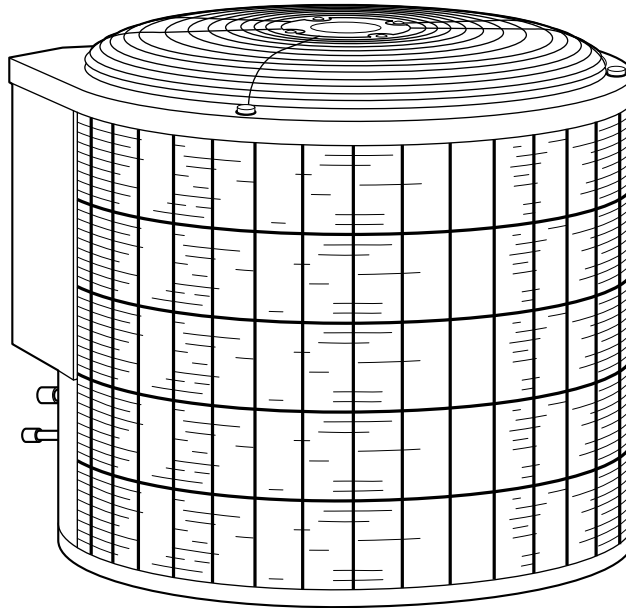

Fig. 1—Model PA12NA

A92461

**NOTE:** Read the entire instruction manual before starting the installation.

## SAFETY CONSIDERATIONS

Improper installation, adjustment, alteration, service, maintenance, or use can cause explosion, fire, electrical shock or other conditions which may cause personal injury or property damage. Consult a qualified installer, service agency, or your distributor or branch for information or assistance. The qualified installer or agency must use factory-authorized kits or accessories when modifying this product. Refer to the individual instructions packaged with the kits or accessories when installing.

Follow all safety codes. Wear safety glasses and work gloves. Use quenching cloth for brazing operations. Have fire extinguisher available. Read these instructions thoroughly and follow all warnings or cautions attached to the unit. Consult local building codes and National Electrical Code (NEC) for special requirements.

Recognize safety information. This is the safety-alert symbol . When you see this symbol on the unit and in instructions or manuals, be alert to the potential for personal injury.

Understand the signal words DANGER, WARNING, and CAUTION. These words are used with the safety-alert symbol. DANGER identifies the most serious hazards which **will** result in severe personal injury or death. WARNING signifies hazards which **could** result in personal injury or death. CAUTION is used to identify unsafe practices which **would** result in minor personal injury or product and property damage.

---

 **WARNING:** Before installing or servicing system, always turn off main power to system. There may be more than 1 disconnect switch. Turn off accessory heater power if applicable. Electrical shock can cause personal injury or death.

---

## INSTALLATION

### PROCEDURE 1—CHECK EQUIPMENT AND JOBSITE

#### A. Unpack Unit

Move to final location. Remove carton taking care not to damage unit.

#### B. Inspect Equipment

File claim with shipping company prior to installation if shipment is damaged or incomplete. Locate unit rating plate on unit service panel. (See Fig. 2.) It contains information needed to properly install unit. Check rating plate to be sure unit matches job specifications.

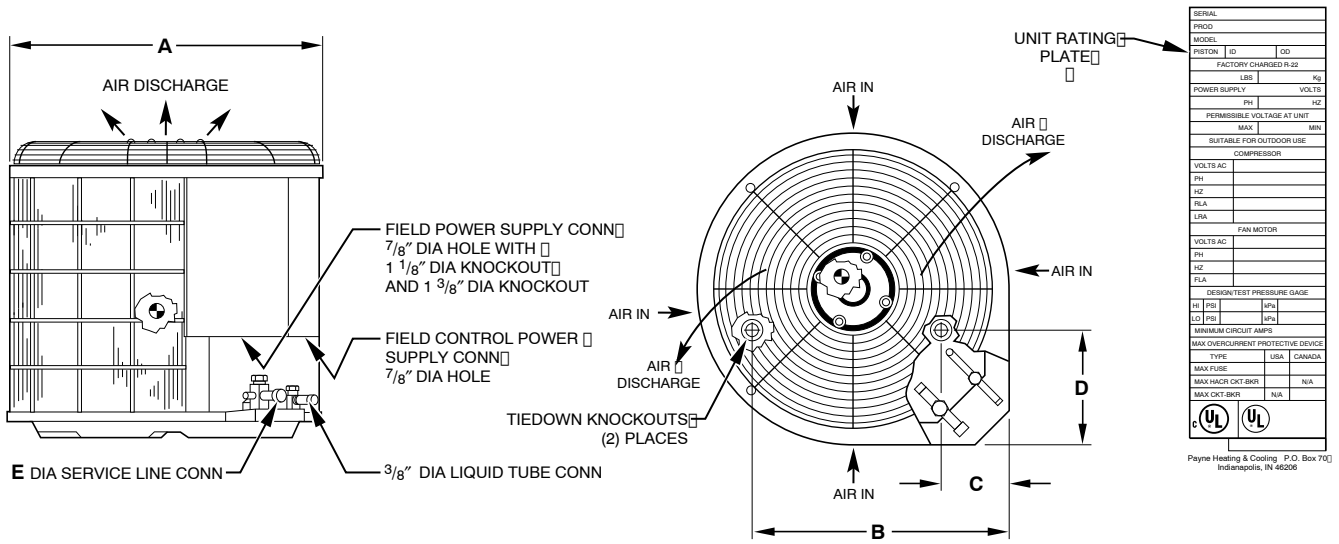

A92490

UNIT SIZE	A	B	C	D	E
	In.	In.	In.	In.	In.
024	30	23-1/2	6-1/2	10	5/8
030, 036	30	23-1/2	6-1/2	10	3/4
042-060	30	23-1/2	6-1/2	10	7/8

Fig. 2—Unit Reference Drawing

**PROCEDURE 2—INSTALL ON A SOLID, LEVEL MOUNTING PAD**

If conditions or local codes require unit be attached to pad, tie-down bolts should be used and fastened through knockouts provided in unit base pan. Refer to unit mounting pattern in Fig. 2 to determine base pan size and knockout hole locations.

When installing, allow sufficient space for airflow clearance, wiring, refrigerant piping, and service. Allow 30-in. clearance to service end of unit and 48 in. above unit. For proper airflow, a 6-in. clearance on 1 side of unit and 12 in. on all remaining sides must be maintained. Maintain a distance of 24 in. between units. Position so water, snow, or ice from roof or eaves cannot fall directly on unit.

On rooftop applications, locate unit at least 6 in. above roof surface. Place unit above a load-bearing wall and isolate unit and tubing set from structure.

Arrange supporting members to adequately support unit and minimize transmission of vibration to building. Consult local codes governing rooftop applications.

**PROCEDURE 3—REPLACE INDOOR CHECK-FLO-RATER® PISTON, IF REQUIRED**

Check indoor coil piston to see if it matches required piston shown on unit rating plate. If it does not match, replace indoor coil piston with piston shipped with outdoor unit. The piston shipped with outdoor unit is correct for any approved indoor coil combination.

**PROCEDURE 4—MAKE PIPING CONNECTIONS**

Outdoor units may be connected to indoor sections using accessory tubing package or field-supplied refrigerant grade tubing of correct size and condition. For tubing requirements beyond 50 ft, consult Long-Line Application Guideline which is available at your local distributor.

**NOTE:** In some cases noise in living area has been traced to gas pulsations from improper installation of equipment.

**A. Installation Recommendations**

1. Locate unit away from windows.
2. Ensure that vapor and liquid line diameters are appropriate to capacity of unit. (See Table 1.)
3. Run refrigerant tubes as directly as possible by avoiding unnecessary turns and bends.
4. Leave some slack between structure and unit to absorb vibration.
5. When passing refrigerant tubes through wall, seal opening with RTV or other pliable silicon-based caulk. (See Fig. 3.)
6. Avoid direct lineset contact with water pipes, ductwork, floor joists, wall studs, floors, and walls.
7. Do not suspend refrigerant tubing from joists and studs with a rigid wire or strap which comes in direct contact with tubing. (See Fig. 3.)
8. Ensure that tubing insulation is pliable and completely surrounds vapor line.
9. When necessary, use hanger straps which are 1-in. wide and conform to shape of tubing insulation. (See Fig. 3.)
10. Isolate hanger straps from insulation by using metal sleeves bent to conform to shape of insulation.

If refrigerant tubes or indoor coil is exposed to atmospheric conditions for longer than 5 minutes, it must be evacuated to 500 microns to eliminate contamination and moisture in system.

**⚠ CAUTION: DO NOT BURY MORE THAN 36 IN. OF REFRIGERANT TUBING IN GROUND. If any section of tubing is buried, there must be a 6-in. vertical rise to valve connections on outdoor unit. If more than recommended length is buried, refrigerant may migrate to cooler buried section during extended periods of unit shutdown, causing refrigerant slugging and possible compressor damage at start-up.**

**NOTE:**  
AVOID CONTACT BETWEEN TUBING AND STRUCTURE

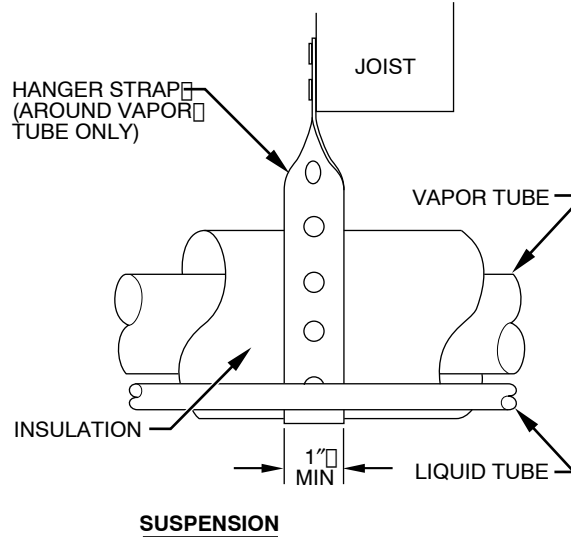
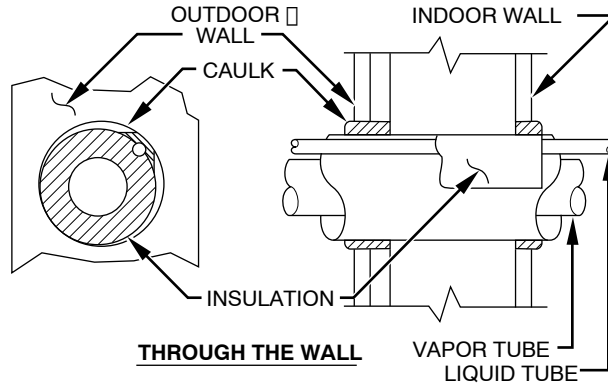

**Fig. 3—Piping Installation**

A92469

**Table 1—Refrigerant Connections and Recommended Liquid and Vapor Tube Diameters (In.)**

UNIT SIZE	LIQUID		VAPOR	
	Connect Diameter	Tube Diameter	Connect Diameter	Tube Diameter
024	3/8	3/8	5/8	5/8
030, 036	3/8	3/8	3/4	3/4
042, 048	3/8	3/8	7/8	7/8
060	3/8	3/8	7/8	1-1/8

Note: Tube diameters are for lengths up to 50 ft. For tubing lengths greater than 50 ft, consult your local distributor or Long-Line Application Guideline.

**B. Outdoor Units Connected to Factory-approved Indoor Units**

Outdoor unit contains correct system refrigerant charge for operation with indoor unit of same size when connected by 15 ft of field-supplied or factory accessory tubing. Check refrigerant charge for maximum efficiency. (See Procedure 10—Checking Charge.)

**C. Install Solenoid Valve in Liquid Tube**

**⚠ CAUTION: All models require liquid line solenoid for performance enhancement. Solenoid valve must be energized during evacuation for complete removal.**

Before making liquid tube connections, install factory-supplied solenoid valve on indoor liquid tube fitting. (See Fig. 4.) Be sure to use flare adapter supplied with indoor coil when making connections.

**⚠ CAUTION: If a field-supplied power source is needed when adding solenoid, wiring must comply with local codes and NEC requirements.**

1. Remove coil liquid connection cap and discard.
2. Mount solenoid valve on liquid tube, making sure valve flow arrow points toward indoor coil. Mount valve in any position except valve body at top and electric coil at bottom. (See Fig. 4.) The solenoid valve is to be installed a maximum of 2 ft from indoor coil.

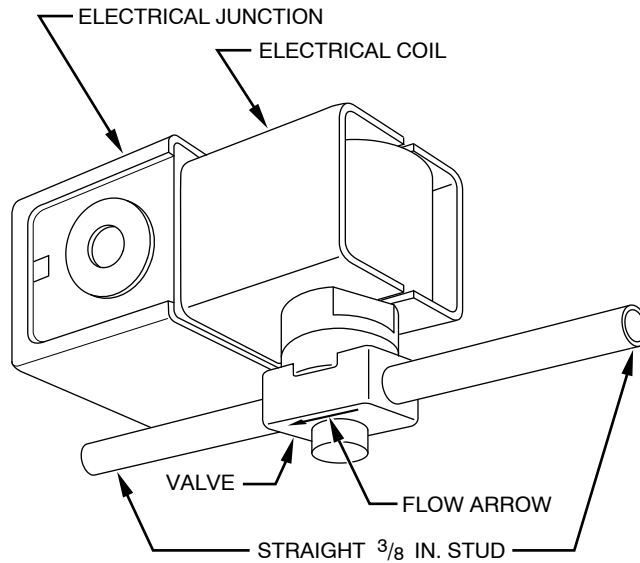

**NOTE:** System flow direction must match arrow on bottom of body.

A87044

**Fig. 4—Solenoid Valve Installation**

3. Braze valve onto end of liquid tube using silver bearing or non-silver bearing brazing material. Consult local code requirements.
4. Braze flare adapter onto outlet end of solenoid valve.
5. Wire solenoid coil into system control circuit as shown in Fig. 6.

#### **PROCEDURE 5—REFRIGERANT TUBING**

Connect tubing to fittings on outdoor unit vapor and liquid service valves. (See Fig. 2.)

---

**⚠ CAUTION:** To avoid valve damage while brazing, service valves must be wrapped with a heat-sinking material such as a wet cloth.

---

#### **A. Sweat Connection**

Use refrigerant grade tubing. Service valves are closed from factory and ready for brazing. After wrapping service valve with a wet cloth, tubing set can be brazed to service valve using either silver bearing or non-silver bearing brazing material. Consult local code requirements. Refrigerant tubing and indoor coil are now ready for leak testing. This check should include all field and factory joints.

#### **PROCEDURE 6—MAKE ELECTRICAL CONNECTIONS**

---

**⚠ WARNING:** To avoid personal injury or death, do not supply power to unit with compressor terminal box cover removed.

---

Be sure field wiring complies with local and national fire, safety and electrical codes, and voltage to system is within limits shown on unit rating plate. Contact local power company for correction of improper voltage. See unit rating plate for recommended circuit protection device.

**NOTE:** Operation of unit on improper line voltage constitutes abuse and could affect unit reliability. See unit rating plate. Do not install unit in system where voltage or phase imbalance may fluctuate above or below permissible limits.

**NOTE:** Use copper wire only between disconnect switch and unit.

**NOTE:** Install branch circuit disconnect per NEC of adequate size to handle unit starting current. Locate disconnect within sight from and readily accessible from unit, per Section 440-14 of NEC.

#### **A. Route Ground and Power Wires**

Remove access panel to gain access to unit wiring. Extend wires from disconnect through power wiring hole provided and into unit control box. (See Fig. 2.)

---

**⚠ WARNING:** According to NEC, ANSI/NFPA 70, and local codes, cabinet must have an uninterrupted or unbroken ground, to minimize personal injury if an electrical fault should occur. The ground may consist of electrical wire or metal conduit when installed in accordance with existing electrical codes. Failure to follow this warning could result in an electric shock, fire, or death.

---

#### **B. Connect Ground and Power Wires**

Connect ground wire to ground connection in control box for safety. Connect power wiring to contactor as shown in Fig. 5.

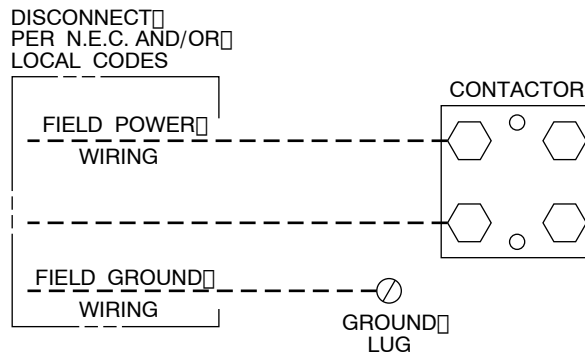

A88174

**Fig. 5—Line Power Connections(1 Phase)**

### C. Connect Control Wiring

Route 24-v control wires through control wiring grommet and connect leads to control wiring. (See Fig. 6.)

Use No. 18 AWG color-coded, insulated (35° C minimum) wires. If thermostat is located more than 100 ft from unit, as measured along control voltage wires, use No. 16 AWG color-coded wires to avoid excessive voltage drop.

Use furnace transformer, fan-coil transformer, or accessory transformer for control power, 24-v/40-va minimum.

**NOTE:** Use of available 24-v accessories may exceed minimum 40-va power requirement. Determine total transformer loading and increase transformer capacity or split load with an accessory transformer as required.

#### PROCEDURE 7—COMPRESSOR CRANKCASE HEATER

A crankcase heater is required if refrigerant tubing is longer than 50 ft.

#### PROCEDURE 8—INSTALL ELECTRICAL ACCESSORIES

Refer to individual instructions packaged with kits or accessories when installing.

#### PROCEDURE 9—START-UP

1. When equipped with a crankcase heater, energize heater a minimum of 24 hr before starting unit. To energize heater only, set thermostat to OFF mode and close electrical disconnect to outdoor unit.

---

**⚠ CAUTION: Service valve gage ports are equipped with Schrader valves. To prevent personal injury, wear safety glasses and gloves when handling refrigerant.**

---

2. Fully open liquid and vapor service valves.
3. Unit is shipped with valve stem(s) front seated, and caps installed. Replace stem caps after system is opened to refrigerant flow. Replace caps finger-tight and tighten additional 1/6 turn with wrench.
4. Close electrical disconnects to energize system.
5. Set room thermostat at desired temperature. Be sure set point is below indoor ambient temperature.
6. Set room thermostat at COOL and fan ON or AUTO modes, as desired. Operate unit for 15 minutes. Check system refrigerant charge. See Checking Charge section below.

---

**⚠ WARNING: Relieve pressure and recover all refrigerant before system repair or final unit disposal to avoid personal injury or death. Use all service ports and open all flow control devices, including solenoid valves.**

---

#### PROCEDURE 10—CHECKING CHARGE

Factory charge is shown on unit rating plate. (See Fig. 2.) Charge procedure is shown on information plate.

---

**⚠ CAUTION: Compressor damage may occur if system is overcharged.**

---



---

**⚠ CAUTION: Do not vent refrigerant to atmosphere. Recover during system repair or final unit disposal.**

---

### CARE AND MAINTENANCE

For continuing high performance, and to minimize possible equipment failure, it is essential that periodic maintenance be performed on this equipment. Consult your servicing contractor or User's Manual for proper frequency of maintenance. Frequency of maintenance may vary depending upon geographic areas, such as coastal applications.

Leave User's Manual with homeowner. Explain system operation and maintenance procedures outlined in manual.

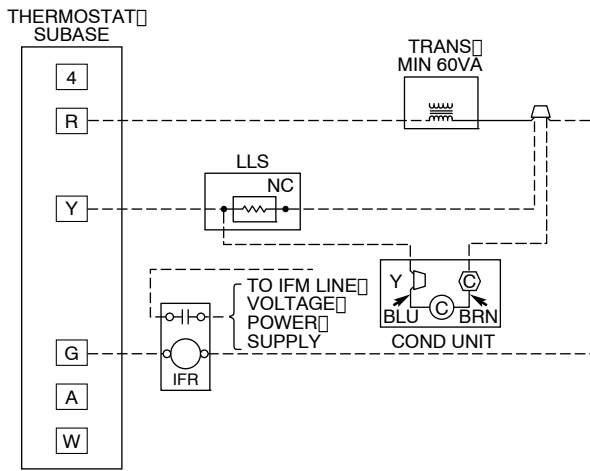

ARRANGEMENT A—COOLING ONLY

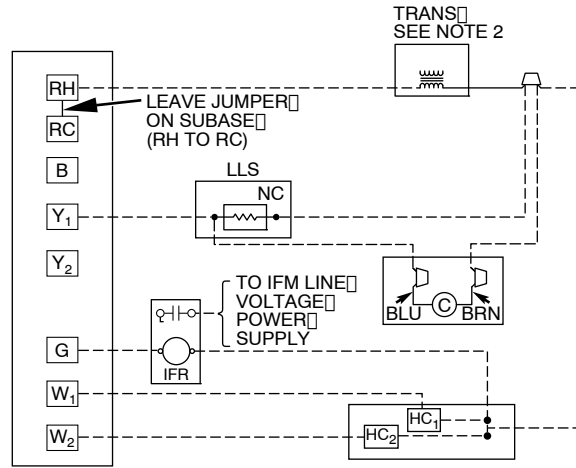

ARRANGEMENT C—1 TRANSFORMER; COOLING AND 2-STAGE HEATING

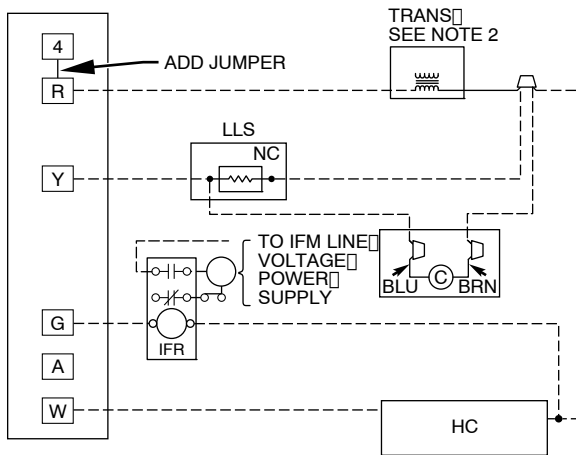

ARRANGEMENT B—1 TRANSFORMER; COOLING AND 1-STAGE HEATING

- NOTES:**
1. REFER TO UNIT LABEL WIRING DIAGRAM FOR WIRE COLORS. IFR, IFM AND LLS ARE LOCATED INDOORS ON HEATING-COOLING APPLICATIONS. IF ACCESSORY IFR IS REQUIRED FOR COOLING-ONLY APPLICATIONS, LOCATE IFR IN FAN COIL.
  2. N.E.C. CLASS 2, 24V CIRCUIT, MIN 40VA REQUIRED.

- C — CONTACTOR
- HC — HEATING CONTROL
- IFM — INDOOR FAN MOTOR
- LLS — LIQUID LINE SOLENOID VALVE
- NC — NORMALLY CLOSED
- TRANS — TRANSFORMER

Fig. 6—Typical 24-v Circuit Connections

A93199



