

Read this User's Manual thoroughly for safety before operating the unit.

Wear safety glasses for eye protection.

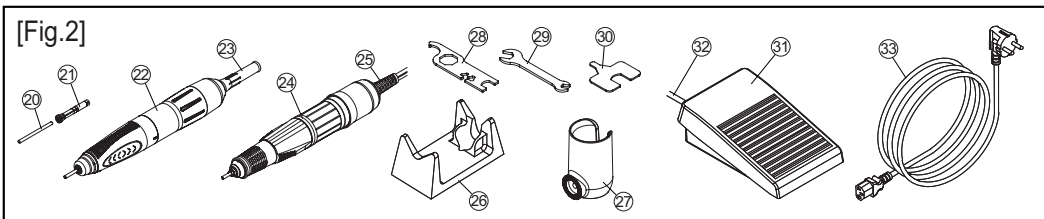
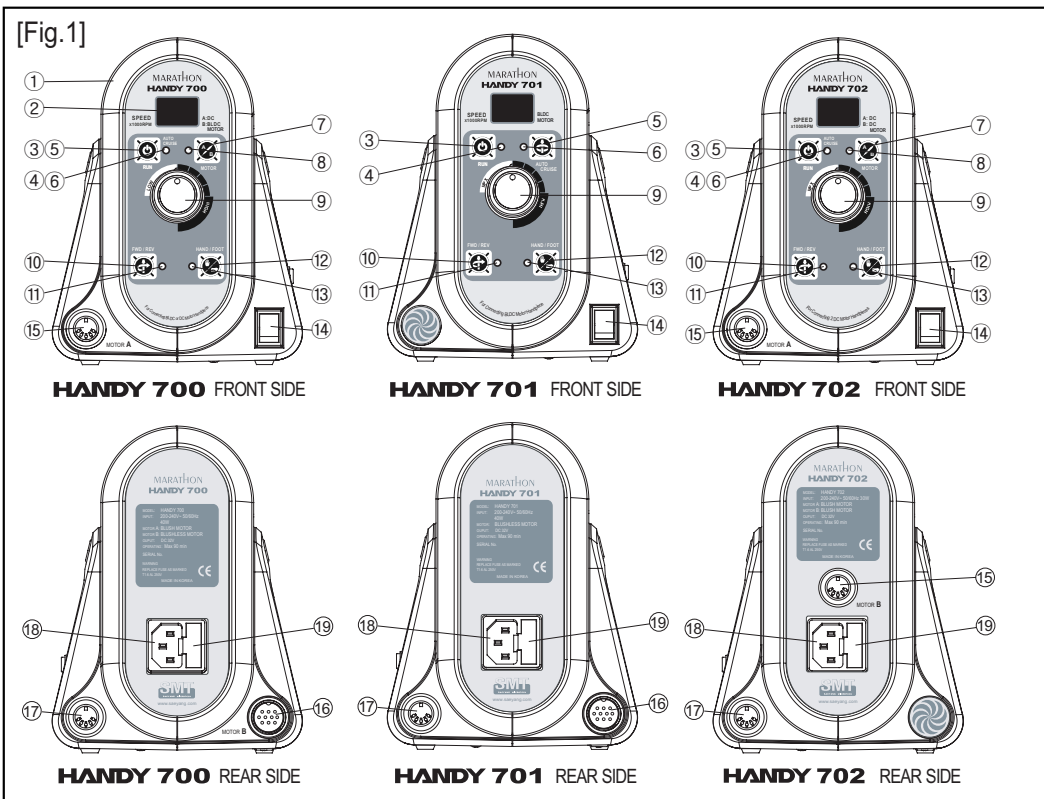

1. Components

- | | | | |
|-----------------------------------|--------------------------------|------------------------|-------------------|
| ① Control Unit | ⑪ Forward/Reverse Selector LED | ⑳ Collet Chuck | ⑳ Foot Pedal |
| ② Speed Display | ⑫ Hand/Foot Selector Switch | ㉑ BLDC Motor Handpiece | ㉒ Foot Pedal Cord |
| ③ Motor Run Switch | ⑬ Hand/Foot Selector LED | ㉓ BLDC Motor Cord | ㉔ Power Cord |
| ④ Motor Run LED | ⑭ Power Switch(Power Lamp) | ㉕ DC Motor Handpiece | |
| ⑤ Auto Cruise Switch | ⑮ DC Motor Connector | ㉖ DC Motor Cord | |
| ⑥ Auto Cruise LED | ⑯ BLDC Motor Connector | ㉗ Handpiece Stand | |
| ⑦ Motor Selector Switch | ⑰ Foot Pedal Connector | ㉘ Handpiece Holder | |
| ⑧ Motor Selector LED | ⑱ Power Connector | ㉙ Chuck Wrench | |
| ⑨ Speed Control Knob | | ㉚ Spanner | |
| ⑩ Forward/Reverse Selector Switch | ㉛ Test Bur | ㉜ Chuck Joint Wrench | |

※ REFERENCE

- BLDC MOTOR indicates Brushless DC micromotor.
- DC MOTOR indicates Carbon brush micromotor.

2. Complete set[Fig.3]

- Control Unit, Power Cord
- Handpiece Holder, Bolt, Washer
- Handpiece
- Handpiece Stand
- Foot Pedal
- Tools

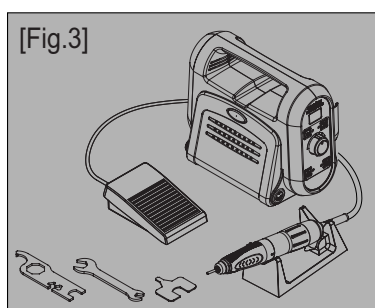

3. AC power input

- 3.1 Check the electric rating label (AC100~120V, 50/60Hz or AC200~240V, 50/ 60Hz) affixed to the rear of the Control Unit[Fig.4]
- 3.2 Replace fuse with identical type and rating only.(T3.15AL 250V in case of AC100~120V, T1.6AL 250V in case of AC 200~240V) The Fuse Holder ⑱ contains a spare fuse.[Fig.5]

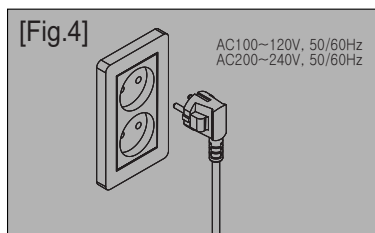

⚠ CAUTION

- Never plug or unplug the Power Cord with wet hands to avoid electric shock.
- Use only an earthed(grounded) AC power receptacle.

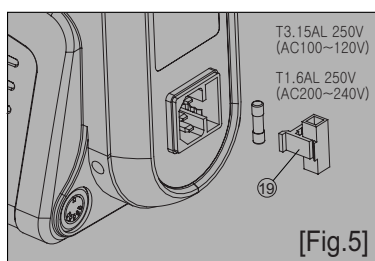

4. Installation

- 4.1 The Control Unit ① should be installed on the working table. [Fig.6]

⚠ CAUTION

- The Control Unit should rest on a flat, steady surface. Avoid blocking the ventilation openings in the bottom of the case.
- Use the Control Unit in locations that have a temperature range between 0~40℃. Avoid excessively dusty, hot, or humid locations.

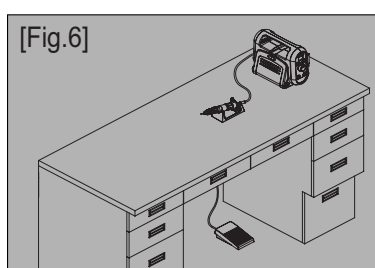

5. Mounting and electric connection

- 5.1 Fix the Handpiece Holder ㉘ to the right side of the Control Unit with bolt and washer.[Fig.7]
- 5.2 Plug the DC Motor Cord ㉕ into the DC Motor Connector ⑮ located in the front of the Control Unit.[Fig.8]
- 5.3 Plug the BLDC Motor Cord ㉓ into the BLDC Motor Connector ⑯ located in the rear of the Control Unit and then tighten the plug nut.[Fig.9]
- 5.4 Plug the Foot Pedal Cord ㉒ into the Foot Pedal Connector ⑰ located in the rear of the Control Unit.[Fig.9]
- 5.5 Plug the Power Cord ㉔ into the Power Connector ⑱ in the rear of the Control Unit.[Fig.9]

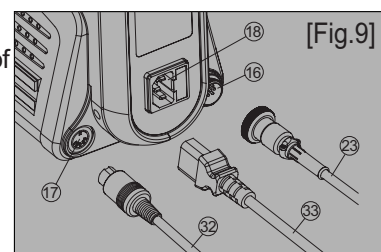
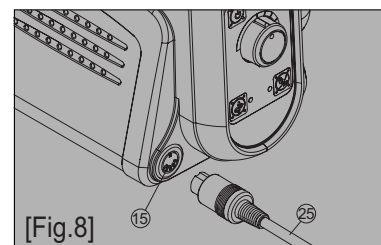
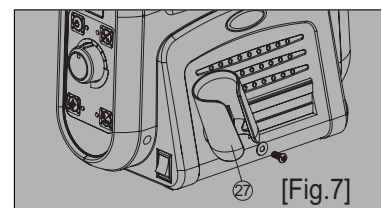

※ REFERENCE

- You can put the several kinds of tool burs on the surface of magnetic bur holder which is installed in side of controller. (Protect from ferrous metal dust.)[Fig.10]

⚠ CAUTION

- Make sure that all cords are connected safely and properly and that the Power Switch is off before plugging in the Power Cord.

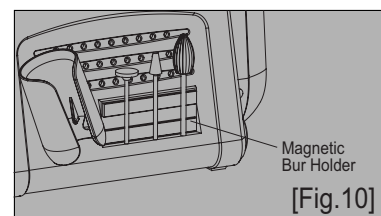

6. How to operate

- Set Power Switch to off.
- Plug the Power Cord ㉔ into an electric outlet.
- Set the Speed Control Knob ⑨ to the slowest position.
- Turn on the Power Switch ⑭ .
- Select motor A or B by momentarily pressing Motor Selector Switch ⑦ . (except for HANDY701)

HANDY700	MOTOR A (DC Motor Handpiece)	Motor Selector LED ⑧ lights green color
	MOTOR B (BLDC Motor Handpiece)	Motor Selector LED ⑧ lights orange color
HANDY702	MOTOR A (DC Motor Handpiece)	Motor Selector LED ⑧ lights green color
	MOTOR B (DC Motor Handpiece)	Motor Selector LED ⑧ lights orange color

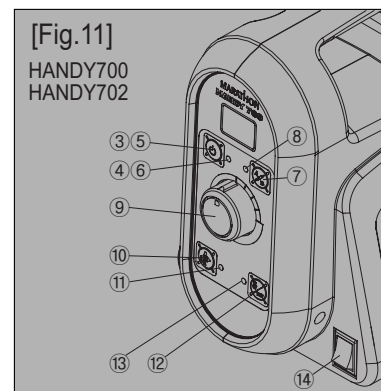

- Select the rotation direction by pressing Forward/Reverse Selector Switch ⑩ .

- 6.1 For hand mode operation, follow steps a. through f.
- g. Press the Hand/Foot Selector Switch ⑫ to "HAND". (Hand/Foot Selector LED ⑬ lights green color)
- h. Press the Motor Run Switch ③ to run the motor. (Motor Run LED ④ lights green color)
- i. Set the Speed Control Knob ⑨ to desired speed.
- j. The motor stops by pressing again the Motor Run Switch ③ .(Motor Run LED ④ is turned off)

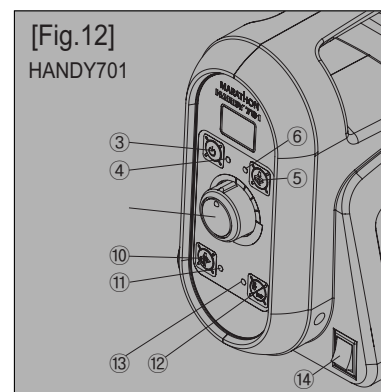

- 6.2 For foot mode operation, follow steps a. through f.
- g. Press the Hand/Foot Selector Switch ⑫ to "FOOT".(Hand/Foot Selector LED ⑬ lights orange color, Motor Run LED ④ lights green color)
- h. Set the Speed Control Knob ⑨ to desired maximum speed.
- i. Press the Foot Pedal ㉒ to run the motor.

6.3 Auto Cruise Mode

- When the Foot Pedal is used, the Auto Cruise feature allows the speed to be maintained when pressure is removed from the Foot Pedal. Activate by pressing the Auto Cruise Switch ⑤ and keeping the Foot Pedal depressed for 2 seconds. Deactivate by pressing the Foot Pedal.

⚠ CAUTION

- Do not exceed the maximum operating speed of the Control Unit because its operation at too high speed may result in damage to the handpiece, as well as personal injury.
- Before turning off the Power Switch, it is surely required to make sure that the motor has been stopped.
- When the unit is not in use, for maximum safety, unplug the Power Cord.

7. Rotation speed display set mode

- This function is for using the motor handpiece in safety to set display of maximum rotation speed.
- a. Turn on the Power Switch ⑭ while pressing the Motor Run Switch ③ and wait for a beep. Release the Motor Run Switch.
- b. Select the desired motor mode "dc" or "bc" by pressing the Motor Select Switch ⑦ .
- c. Set the maximum speed of the motor handpiece which you want to use by repeatedly pressing the Hand/Foot Selector switch ⑫ .

Model	Switch	Motor Selector Switch ⑦	Hand/Foot Selector Switch ⑫
HANDY700	MOTOR A	"dc" displayed(DC Motor Handpiece)	25,30,35,40,45,50(x1,000rpm)
	MOTOR B	"bc" displayed(BLDC Motor Handpiece)	"
HANDY701		"bc" displayed(BLDC Motor Handpiece)	"
HANDY702	MOTOR A	"d1" displayed(DC Motor Handpiece)	"
	MOTOR B	"d2" displayed(DC Motor Handpiece)	"

⚠ CAUTION

- Please use this set mode only when you change to operate with other kind of micromotor handpiece which has different specification of motor.

8. Maximum Torque Set Mode

- This setting is used to match the maximum output of the control unit to the maximum torque capability of the handpiece, or to prevent damage to the bur.
- a. Turn on the Power Switch ⑭ while simultaneously pressing Forward/Reverse Selector Switch ⑩ when you hear a beep, release the Forward/Reverse Selector Switch.
- b. Refer to the table below. Select the motor for setting maximum torque, c1/Motor A, c2/Motor B, by pressing the Motor Select switch ⑦.
- c. Set the electric current (ampere) value for maximum torque of the motor handpiece by pressing Hand/Foot Selector switch ⑫ repeatedly until the desired amperage value is displayed. The higher the current value, the more powerful the torque.

Model	Switch	Motor Selector Switch ⑦	Hand/Foot Selector Switch ⑫	recommended
HANDY700	MOTOR A	"c1" displayed	1a, 2a, 3a, 4a, 5a	less than 3a
	MOTOR B	"c2" displayed	1a, 2a, 3a, 4a, 5a, 6a, 7a	less than 6a
HANDY701		"c1" displayed	1a, 2a, 3a, 4a, 5a, 6a, 7a	less than 6a
HANDY702	MOTOR A	"c1" displayed	1a, 2a, 3a, 4a, 5a	less than 3a
	MOTOR B	"c2" displayed	1a, 2a, 3a, 4a, 5a	less than 3a

CAUTION

Do Not select a current value which exceeds the rating of the motor handpiece, which may cause shortening motor life or damage the control unit.(Consult a qualified technician if possible.)

※ REFERENCE

To check the values of maximum rotation speed and maximum torque which are already set, turn on the Power Switch ⑭ while simultaneously pressing Motor Select Switch ⑦ (Auto Cruise Switch ⑤ in Handy 701), the set values are on the Speed Display LED ② one by one.

9. Handling of the Motor Handpiece(SDE-BH60)

9.1 Insertion or Removal of Bur

The Bur ⑳ can be replaced by turning the Chuck Handle clockwise. After replacing the Bur, the Chuck Handle must be turned counterclockwise to be securely held. [Fig.13]

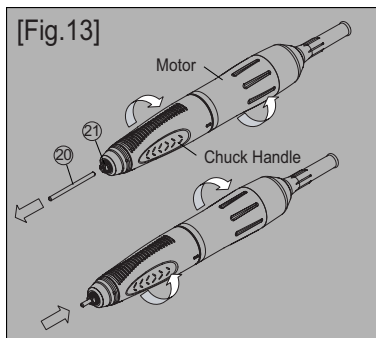

9.2 How to mount and dismount the Collet Chuck

Turn the Collet Chuck ㉑ counterclockwise while opened to dismount. If the Collet Chuck can not be turned manually, use the Chuck Wrench ㉒ to dismount it. To mount the Collet Chuck, it is required to first open the Chuck Handle and then insert the Collet Chuck and the Bur. [Fig.14]

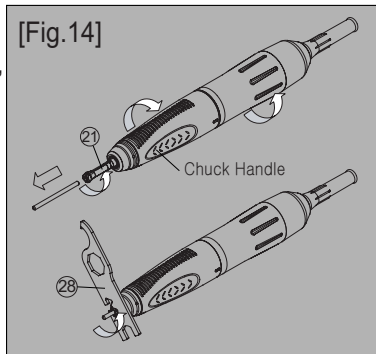

9.3 How to disassemble the Chuck Handle and the Motor

The Chuck Handle and the Motor are disassemble by continuously turning the Chuck Handle counter clockwise. [Fig.15]

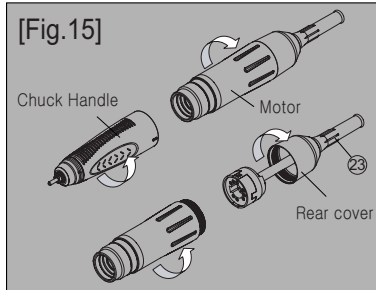

9.4 How to disassemble the Motor and the Motor Cord

The Motor Cord ㉓ is disassembled by continuously turning the Motor counterclockwise.[Fig.15]

CAUTION

- Use only recommended burs.
- Always remove dirt before replacing a bur.
- After replacing a bur, make sure that the Collet Chuck is securely held before running the Motor.
- DO NOT try to adjust the Chuck Handle while the motor is running to prevent the unit from being damaged.
- When the Motor Handpiece is not in use, it is recommended that a bur is kept inserted in the Chuck.
- Always put the Motor Handpiece on the Handpiece Stand ㉔ or Handpiece Holder ㉕ while not in use.[Fig.9] Special care must be taken not to drop it on the floor.
- Thoroughly clean the Collet Chuck and Burs before reassembling. Clean at least once a week for longer life.
- Special care must be taken that the Chuck Handle and the Motor are free from and dirt during disassembly.
- The spindle and the motor should be disassembled only by a qualified repair facility.

10. Allowable rotation speed

10.1 This chart is a general guide for the maximum rotation speed of conventional burs. The allowable rotation speed can be slightly different, depending on bur materials or types.

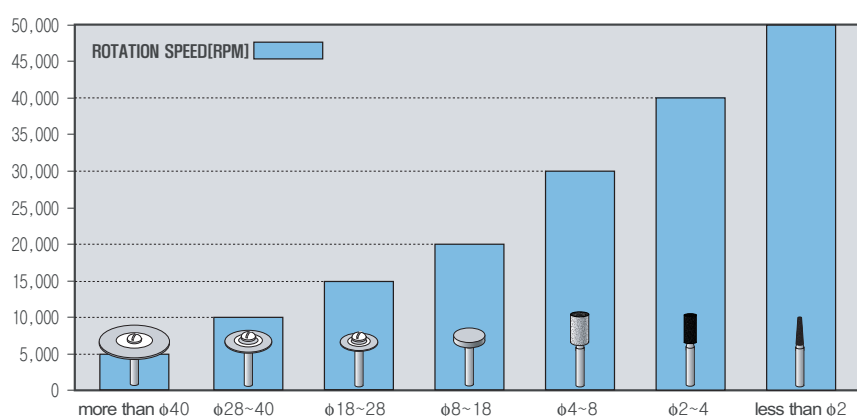

CAUTION

- Make sure not to exceed the maximum rotation speed specified by the manufacturer or distributor for the bur being used.
- Large burs, even when operated below maximum rated speed, may begin to vibrate. Speed should be reduced immediately to prevent damage to the bur, handpiece, or operator.
- Always use standard burs.

- Be sure to insert the Bur shank all the way, until it touches the back of the Collet Chuck. Then tighten the Collet Chuck. If the Bur is used while not inserted completely, it is very dangerous because vibration may cause it to come out.

11. Technical data

11.1 Error code

Error code	Status	Cause
"1E"	Motor sensor error	1. One or more hall sensors defective 2. The Motor Cord is unplugged or defective. 3. The Motor Cord is broken.
"2E"	Motor lock error	1. The Collet Chuck is opened. 2. The Motor Handpiece is mechanically defective. 3. The Motor Handpiece is electrically defective.
"4E"	Overvoltage detection error	1. The circuit of the Control Unit is defective.
"5E"	Overheat error	1. The Control Unit has been excessively operated under a high load condition for too long time. 2. The Control Unit has been exposed to an excessive hot environment. 3. Air openings are blocked. 4. Temperature sensor is troubled.
"6E"	Overdrive error	1. The operated under a high load condition or it was suddenly stopped after being started in good condition.

11.2 Troubleshooting

Troubles	Check points	Corrective actions	
The Power Lamp does not light.	Make sure that the Power Cord is correctly plugged into the outlet and the control unit.	Correctly plug in the Power Cord.	
	Check that the fuse is blown.	Replace with a recommended fuse. If the fuse is blown again, repair the unit.	
	Make sure that the Power Switch is working properly.	Repair if the Power Switch is defective.	
The motor does not run.	"1E" displayed	Check that the Motor Cord is plugged in properly. Correctly plug in the Motor Cord. If the same error is continuously displayed, replace the Motor Cord.	
	"2E" displayed	Check if the Collet Chuck is opened. If opened, close the Collet Chuck. If the same error is still displayed, then repair it.	
	"4E" displayed	The circuit of the Control Unit it is defective. Repair it.	
	"5E" displayed	Check if the Control Unit has been used at a high load for a long time.	Restart the Control Unit after keeping it stopped for about 10 minutes. If the same error is still displayed, repair it.
		Check if work place temperature is too high.	If too warm, move the Control Unit to a location an indoor temperature of 0 ~ 40 °C.
		Check if control air opening is blocked. Temperature sensor is troubled.	Unblock air opening. Repair it.
"6E" displayed	Check if the Control Unit has been excessively used under a high load condition.	Press the Auto Cruise Switch or turn off, then on, then press the Motor Run Switch. If the same error is still displayed, then repair it.	
	Check if the Collet Chuck is opened. Check if the shaft of the Motor Handpiece can rotate freely.	If opened, tighten it by turning the Chuck Handle. If it cannot be rotated with the chuck closed, the spindle of the Motor Handpiece is defective. Repair it.	
The Foot Pedal does not work.	Make sure that the Foot Pedal Cord is properly plugged in.	Plug in the Foot Pedal Cord correctly.	
	The Hand/Foot Selector Switch is set to "HAND".	Set the Hand/Foot Selector Switch to "FOOT".	
The Motor Handpiece overheats while in operation.	The ball bearings are defective.	Repair the Motor Handpiece.	
The Motor Handpiece vibrates excessively and is unusually noisy.	Make sure that the Collet Chuck is free from dirt.	Thoroughly clean the Collet Chuck.	
	The rotation speed is too high.	Reduce the rotation speed. Refer to "Allowable rotation speed" chart.	
	Check if the bur shaft.	Replace with new one.	
	Make sure that ball bearings are in good condition.	Repair the Motor Handpiece.	

12. Specification

- Control Unit

Model Name	Input	Weight	Size	Handpiece type
HANDY700	AC 100~120V 50/60 Hz AC 200~240V 50/60 Hz	2.7kg	137(W)x232(D)x180(H)	Brushless Motor or Brush Motor
HANDY701	"	2.7kg	137(W)x232(D)x180(H)	only Brushless Motor
HANDY702	"	1.9kg	137(W)x232(D)x180(H)	Brush Motor (two connectors)

- Foot Pedal

Model Name	Weight	Size
SDE-FS60N	384g	110(W)x172(D)x42(H)

- Handpiece Stand

Model Name	Weight	Size
SDE-HS10	68g	60(W)x110(D)x45(H)

※ If you have any questions, please do not hesitate to contact us.

SMT
SAEYANG MICROTCH

110B 3L SEONG SEO-IND COMP, 306-107
JANG-DONG, DAL SEO-GU, DAEGU, KOREA.

TEL : 82-53-582-9000~2, FAX: 82-53-581-9003

SEOUL OFFICE(A/S CENTER) TEL : 82-2-775-9023~5, FAX : 82-2-775-9026

http://www.saeyang.com

