

# POS76 II Printer



## User's Manual

---

# Content

|   |    |
|---|----|
| Part 1 Performance Index .....  | 2  |
| Part 2 Operation Specifications .....   | 5  |
| 2.1 Printer Appearance .....  | 5  |
| 2.2 Interface Connection .....  | 5  |
| 2.2.1 Serial Interface .....  | 5  |
| 2.2.2 Parallel Interface .....  | 6  |
| 2.2.3 Cash Drawer Interface .....   | 9  |
| 2.2.4 Power Connection .....  | 9  |
| 2.3 Buttons and Indicators .....  | 9  |
| 2.4 Black Mark Localization Control Specifications .....                      | 10 |
| 2.4.1 Print Structure and Print Control Inherent Relevant<br>Parameters ..... | 10 |
| 2.4.2 Caution for Black Mark print .....                                      | 10 |
| 2.4.3 Black Mark Localization .....   | 10 |
| 2.4.4 Auto Paper Loading .....  | 11 |
| 2.5 Ribbon Installation .....   | 12 |
| 2.6 DIP Setting .....   | 12 |
| Part 3 Print Control Commands .....   | 13 |
| 3.1 Summary .....   | 13 |
| 3.2 Command Descriptions .....  | 13 |
| 3.2.1 Character Control Commands .....  | 13 |
| 3.2.2 Print Position Commands .....   | 16 |
| 3.2.3 Graphics Commands .....   | 19 |
| 3.2.4 Chinese Character Commands .....  | 20 |
| 3.2.5 Black Mark Control Commands .....                                       | 22 |
| 3.2.6 Other Commands .....  | 29 |
| Part 4 Cautions for using .....   | 33 |
| Appendix Index of Print Characters .....                                      | 33 |

---

## Part1 Performance Index

1. Print method: 9-pin serial bi-directional
2. Print density: 42cpl-210(whole dot)/420(half dot)  
40cpl-200(whole dot)/400(half dot)
3. Valid print width: 42cpl-42(7×7)/35(5×7)  
40cpl-40(7×7)/35(5×7)
4. Print speed: for 76mm paper width model: 4.4 lines/sec.  
for 57mm paper width model: 5.6 lines/sec.
5. Feeding speed: 80mm/sec.
6. Print font:
  - IBM character set II, 7×7dots, or 5×7dots
  - GB level I, II Chinese character library, 15×16 dots
  - Character specifications:
    - 5×7dots(W×H): whole dot print, horizontal direction occupies 6 whole dots;
    - 7×7dots(W×H): half dot print, horizontal direction occupies 10 half dots;
  - thereof, the size of a whole dot is:
    - 0. 318mm(W)×0.353mm(H)
7. Interface:
  - parallel interface, DB25(male) socket, 36-pin CENTRONICS (female) socket, 8-bit parallel interface and supports BUSY or / ACK handshaking protocol; TTL signal level;
  - Series interface, DB25(female) socket, supports RTS/CTS protocol;
  - Baud rate: 9600bps/19200bps;
  - Data structure: 1 start bit + 8 data bits + 1 or over 1 stop bit(s), no parity.
  - Cash drawer control: DC24V, 1A, 6-pin RJ-11 socket
8. Print commands: Compatible with EPSON ESC/POS command set

| Command           | Description  |
|-------------------|--|
| HT                | Horizontal Tab   |
| LF                | Print and Feed Line                                      |
| CR                | Carriage Return  |
| ESC SP            | Set Right Spacing of ASCII Characters                    |
| ESC !             | Set Character Print Mode                                 |
| ESC %             | Select/Cancel User-defined Characters                    |
| ESC &             | Define User-defined Characters                           |
| ESC *             | Set Bit-map Graphics Print                               |
| ESC 2             | Set Character Line Spacing to 1/6 Inch                   |
| ESC 3             | Set Character Line Spacing to n/144 Inch                 |
| ESC-n             | On/Off Underline Print                                   |
| ESC p             | Cash Drawer Control                                      |
| ESC v             | Transmit Status of printer                               |
| ESC u             | Transmit Status of Equipment                             |
| ESC <             | Restore Print Head Position                              |
| ESC@              | Initialize Printer                                       |
| ESC D             | Set Horizontal Tab Value                                 |
| ESC J n           | Print and Feed Paper n/144 Inch                          |
| ESC K n           | Print and Return Paper n/144 Inch                        |
| ESC U             | Select/Cancel Single Directional Print                   |
| ESC c 3           | Select Paper Tester                                      |
| ESC c 4           | Set Stopping Print When Paper End                        |
| ESC c 5           | On/Off switch Button function                            |
| ESC d n           | Print and Load paper n Character Lines                   |
| ESC e n           | Print and Return Paper n Character Lines                 |
| ESC t             | Select Character Set                                     |
| FS!               | Set Chinese Print Mode                                   |
| FS w n            | Select/Cancel Chinese Quadruple Mode Print               |
| FS &              | Select Chinese Print Mode                                |
| FS.               | Cancel Chinese Print Mode                                |
| FS2 c1 c2 d1...dk | User-defined Chinese Characters                          |
| FS? c1 c2         | Cancel User-defined Chinese Characters                   |
| FS S n1 n2        | Set Chinese Character Left and Right Spacing             |
| GS (F             | Set Black Mark Localization Offset                       |
| GS FF             | Send Black Mark Paper to The Initial Print Position      |
| GS V m n          | Select Paper Cutting Method and Cut Paper, Present Paper |
| GS r n            | Transmit Status  |

- 
9. Print paper: High quality common white paper or impact paper roll  
Paper width:  $76.2\pm 0.5\text{mm}$  or  $57.5\pm 0.5\text{mm}$   
OD: 83mm (max), ID:  $10\pm 2\text{mm}$   
Paper thickness of per layer:  $0.06\sim 0.085\text{mm}$   
Impact paper roll (1 original + 1 copy)  
Paper thickness:  $0.05\sim 0.08\text{mm}$ ,  
total thickness  $\leq 0.2\text{mm}$
10. Ribbon: ribbon cassette ERC-39 purple or black
11. Black mark test: black mark printed on the right of the front of receipt, its length (along line feeding direction) 5mm, width 12mm(min);  
The reflection rate of black mark part:  $\leq 10\%$ , the reflection rate of other part printed black mark:  $> 75\%$ .
12. Power supply: DC  $24\text{V}\pm 10\%$ , 2A (average), 10A (max)  
power socket: 3-pin socket (A-1009-3P)
13. Buttons and indicators: LF paper feed button and power indicator (green), error indicator (red), paper end indicator (red)
14. Software function: can realize Chinese and ASCII characters printed in the same line; When paper is end, suspend printing, after loaded paper automatically, then can go on printing the remaining contents; Can realize black mark localization print.
15. Dimensions:  
outline dimensions: 160 (W)  $\times$  248 (L)  $\times$  142 (H) mm
16. Reliability: 500 million lines (MCBF)
17. Environment conditions:  
operation temperature:  $5\sim 40^\circ\text{C}$ , relative humidity:  $10\sim 80\%$ ;  
storage temperature:  $-20\sim 60^\circ\text{C}$ , relative humidity:  $10\sim 90\%$
18. Accessories optional: test switch for paper running out
19. Model Specifications:

| Model         | Cutter | Interface                                |
|---------------|--------|--|
| POS76 II -BS  | yes    | serial interface<br>(DB25 female)        |
| POS76 II -BP1 | yes    | 36-pin standard print parallel interface |
| POS76 II -BP2 | yes    | DB25 (male) print parallel interface     |
| POS76 II -DS  | no     | serial interface<br>(DB25 female)        |
| POS76 II -DP1 | no     | 36-pin standard print parallel           |
| POS76 II -DP2 | no     | DB25 (male) print parallel interface     |

## Part 2 Operation Specifications

### 2.1 Printer appearance



### 2.2 Interface Connection

#### 2.2.1 Serial interface

The serial interface of POS76 II is compatible with RS-232C, it uses DB25

(female) socket, supports CTS/RTS handshaking protocol, its baud rate and data structure in serial interface mode are 9600bps/19200bps, 8 data bits, no parity and 1 stop bit.

The pin order of serial port is as Fig. 2-1 shows:

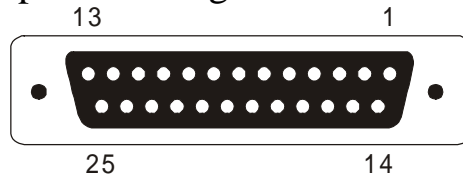

Fig. 2-1 Pin Order of Serial Port

The pin assignment of serial interface is shown in Fig. 2-2:

| Pin No. | Signal | Source  | Description  |
|---------|--------|---------|--|
| 2       | RXD    | Host    | Printer receives data from host  |
| 3       | TXD    | Printer | Printer transmits data to host   |
| 5       | RTS    | Printer | Signal "MARK" indicates that the printer is "BUSY" and unable to receive data; "SPACE" indicates that the printer is "READY" for receiving data. |
| 7       | GND    | ————    | Signal Ground  |

- Note: ① "Source" denotes the source that signal come from;  
 ② Logical signal level is EIA.

Fig.2-2 Pin Assignment of Serial Interface

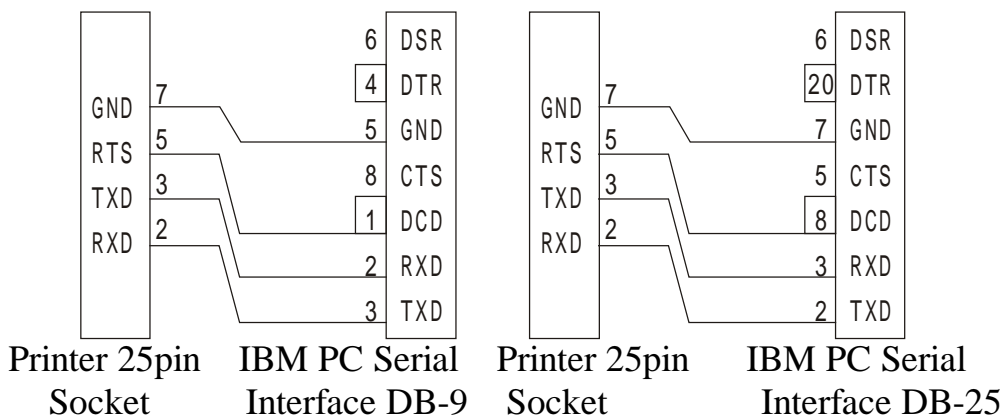

Fig.2-3 Connection between POS 76 II and IBM PC Serial Interface Sketch Map

### 2.2.2 Parallel Interface

The parallel interface of POS76 II is compatible with CENTRONICS, it uses DB25 (male) socket or 36pin CENIRONICS (female) socket which is

optional, supports BUSY and ACK handshaking protocol.

The pin order of DB-25 (male) parallel port is as Fig. 2-4 shows:

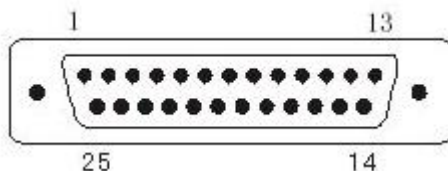

Fig.2-4 Pin Order of Parallel Port

The pin assignment of DB25 parallel interface is shown in Fig. 2-5 shows:

| Pin No.  | Signal | Direction | Description  |
|----------|--------|-----------|--|
| 1        | /STB   | In        | Strobe pulse to latch data, Reading occurs at ringing edge.  |
| 2        | DATA1  | In        | These signals represent the 1 <sup>st</sup> bit to 8 <sup>th</sup> bit of the parallel data representatively, each signal is at HIGH level when data is logic 1, and LOW when data is logic 0. |
| 3        | DATA2  | In        |  |
| 4        | DATA3  | In        |  |
| 5        | DATA4  | In        |  |
| 6        | DATA5  | In        |  |
| 7        | DATA6  | In        |  |
| 8        | DATA7  | In        |  |
| 9        | DATA8  | In        |  |
| 10       | /ACK   | Out       | Answer pulse, LOW level signal indicates that data have already been received and the printer gets ready to receive the next data.   |
| 11       | BUSY   | Out       | HIGH level signal indicates that the printer is BUSY and can not receive data.   |
| 12       | PE     | Out       | HIGH level signal indicates that paper running out.  |
| 13       | SEL    | Out       | Pulling up to HIGH level signal by a resistor indicates that the printer is on line.   |
| 15       | /ERR   | Out       | Pulling up to HIGH level signal by a resistor indicates that there is no error.  |
| 14,16,17 | NC     | ---       | No connection  |
| 18-25    | GND    | ---       | Grounding logical 0 level  |

Note: (1) “In” denotes inputting to the printer, “Out” denotes outputting from the printer.

(2) Signal level is TTL standard.

Fig.2-5 Pin assignment of parallel interface



The pin assignment of 36pin CENTRONICS (female) socket is as following:

| Pin No. | Signal | Direction | Description  |
|---------|--------|-----------|--|
| 1       | /STB   | In        | Strobe pulse to latch data, Reading occurs at falling edge.  |
| 2       | DATA1  | In        | These signals represent the 1 <sup>st</sup> bit to 8 <sup>th</sup> bit of the parallel data representatively, each signal is at HIGH level when data is logic 1, and LOW when data is logic 0. |
| 3       | DATA2  |           |  |
| 4       | DATA3  |           |  |
| 5       | DATA4  |           |  |
| 6       | DATA5  |           |  |
| 7       | DATA6  |           |  |
| 8       | DATA7  |           |  |
| 9       | DATA8  |           |  |
| 10      | /ACK   | Out       | Answer pulse, LOW level signal indicates that data have already been received and the printer gets ready to receive the next data.   |
| 11      | BUSY   | Out       | HIGH level signal indicates that the printer is BUSY and can not receive data.   |
| 12      | PE     | Out       | HIGH level signal indicates that paper running out.  |
| 13      | SEL    | Out       | Pulling up to HIGH level signal by a resistor indicates that the printer is on line.   |
| 32      | /ERR   | Out       | Pulling up to HIGH level signal by a resistor indicates that there is no error.  |
| 34-36   | NC     | ---       | No connection  |
| 19-30   | GND    | ---       | Grounding logical 0 level  |

The timing chart for interface signal of parallel interface is as Fig.2-6 shows:

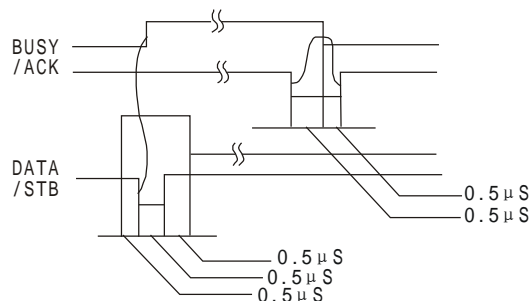

Fig.2-6 Signal Timing Chart of Parallel Interface

### 2.2.3 Cash Drawer Interface

POS76 II adopts the RJ-11, 6-pin socket, as Fig.2-7 shows:



Fig.2-7 Cash Drawer Interface

The pin assignment of the cash drawer interface is defined as follows:

| Pin No. | Signal                           | Direction |
|---------|----------------------------------|-----------|
| 1       | Chassis Ground                   | ---       |
| 2       | Cash Drawer Driver Signal        | Out       |
| 3       | Cash Drawer On/Off Status        | In        |
| 4       | +24VDC                           | Out       |
| 5       | N.C.                             | ---       |
| 6       | Cash Drawer On/Off Signal Ground | ---       |

### 2.2.4 Power Supply Connection

POS76 II uses the external power supply as 24VDC±10%, 2A, power socket is A-1009-3P model, as Fig. 2-8 shows:



Fig.2-8 Power Socket

The pin assignment of the power supply connection is defined as follows:

| Pin No. | Definition |
|---------|------------|
| 1       | +24VDC     |
| 2       | GND        |
| 3       | N.C.       |

Recommend using the power supply that offered by the printer producer, you can plug the power cable into the printer's power socket, if use other power supply, it should meet the specified voltage and power demands, and connection should be correct, otherwise it can't guarantee the printer works normally, even may damage the printer.

## 2.3 Buttons and Indicators

Offer LF paper feed button and power indicator (green), paper out indicator (red), error indicator (red).

1. Self-test mode: hold down the <LF> paper feed button, turn on the power, then self-test begins automatically.
2. LED indicator specifications: while green indicator is on, this means the power is connected, the paper end indicator is on indicates paper is end.

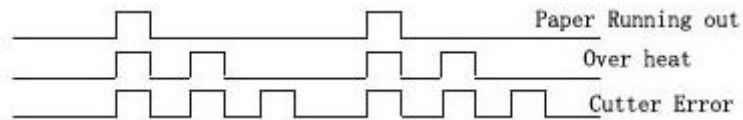

3. Buttons: in black mark mode, press the button once, the printer feeds line to the beginning of the next page. In normal mode, press the button, the printer feeds line forwards.

Error Indicator:

## 2.4 Specifications for black mark localization control

### 2.4.1 Print structure and print control inherent relevant parameters

It is 11mm from the print head of print structure to the position of tearing paper.

It is 28mm from the print head of print structure to the position of black mark test switch.

### 2.4.2 Caution for black mark printing

- ① Black mark must be printed on the right of the front of receipt.
- ② The print size of black mark must be (W × H): 12×5mm.
- ③ The blackness of black mark should be saturated enough, the reflection rate is  $\leq 10\%$  ; the white degree of the other parts of the side that printed black mark should be white enough, the reflection rate  $> 75\%$ .

### 2.4.3 Black Mark Localization

This structure supports localization print of black mark paper, the realization for black mark localization print, please refer to the detailed introduction for black mark control in this manual.

·Selection for black mark localization control

Select through DIP switch.

·Black mark test position

The position of black mark test switch: the relation between initial print position and tearing paper position, please refer to the following figure. The position of black mark tested by the printer is about 2mm in the front of black mark passing through black mark test switch center.

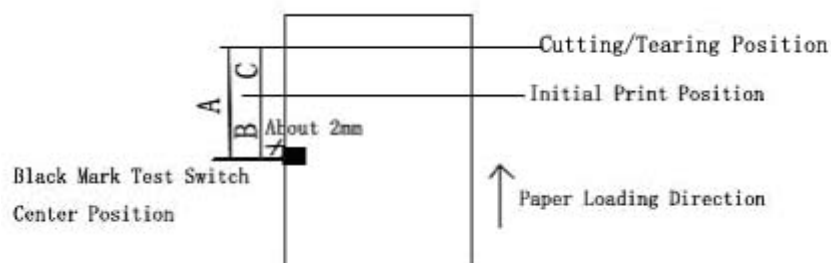

---

B model printer  
A=48mm  
B=28mm  
C=20mm

D model printer  
A=51mm  
B=28mm  
C=23mm

#### 2.4.4 Auto paper loading

When the paper tester switch tests paper run out, paper-end red indicator will turn on, the interface PE signal will turn into " 1 " level (parallel), meanwhile transfer 04H to indicate paper end through serial interface, and wait for loading paper. Open the upper cover, load paper according to the ways shown in the following figure, in the course of paper loading operation, if the paper tester switch tests again paper is available, paper loading driver will be started up, then load paper automatically. If presently black mark localization is valid, paper will be loaded and black mark will be tested automatically, paper will be loaded automatically to the position of the beginning of the page that set by GS CF command. Otherwise it will be loaded to about 80mm.

Notice: When load paper, make sure to line up the paper-in slot so the paper loads smoothly into the printer, slide the paper with even strength until the paper loading driver starts up, and presents the paper out automatically. If there appears paper jam, remove the paper when auto paper loading driver stopped. Cut away the fold part of the paper, load the paper again. After finishing the paper loading, paper-end red indicator goes dark, the interface PE signal turns into " 0 " level (parallel), meanwhile transferring 00H to indicate that paper is available through serial interface, close the upper cover, then tear off smoothly extra paper along paper-out slot that is on the print head. Please load the paper correctly according to the following figure illustrated.

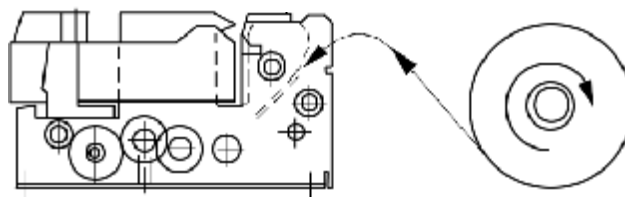

Correct Paper Loading Method

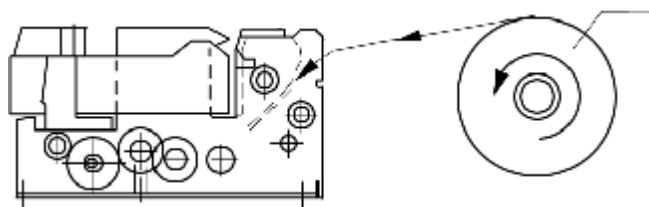

Wrong Paper Loading Method

---

## 2.5 Ribbon Installation

POS76 II adopts ERC-39 (P) ribbon cassette.

Please install the ribbon according to the following steps:

- 1、 Open the upper cover of the printer, and appear the print head.
- 2、 Even up the ribbon according to the direction indicated by the right knob on the ribbon cassette.
- 3、 The knob is on the right, put the ribbon cassette vertically into the printer head, lock the ribbon in the printer head.
- 4、 Rotate the knob again and draw the ribbon straightly.
- 5、 Close the upper cover.

## 2.6 DIP Setting

### DIP Switch1

| DIP | Function              | On              | Off          |
|-----|-----------------------|-----------------|--------------|
| 1   | Reserved              | Reserved        | Reserved     |
| 2   | Cutter Selection      | Yes             | No           |
| 3   | Cutter Mode Selection | Partial Cutting | Full Cutting |
| 4   | Reserved              | Reserved        | Reserved     |

### DIP Switch2

| DIP | Function  | On                     | Off                 |
|-----|---|------------------------|---------------------|
| 1   | Select Number of Characters of Each Line<br>(CPL) (7×7)/(5×7) | 42CPL/35CPL            | 40CPL/33CPL         |
| 2   | Select Printing Paper Width                                   | 57mm                   | 76mm                |
| 3   | Reserved  | Reserved               | Reserved            |
| 4   | Baud Rate (Serial Interface)                                  | 19200bps               | 9600dps             |
| 5   | Select Single/Bi-directional Print                            | Single directional     | Bi-directional      |
| 6   | Select Black Mark Mode  | Black Mark Mode        | Non Black Mark Mode |
| 7   | Select Chinese Character Mode                                 | Chinese Character Mode | ASCII Mode          |

|   |                   |                          |             |
|---|-------------------|--------------------------|-------------|
| 8 | Select Print Mode | HEXADECIMAL<br>Code Mode | Common Mode |
|---|-------------------|--------------------------|-------------|

Ex-factory Setting  
POS76 II -B

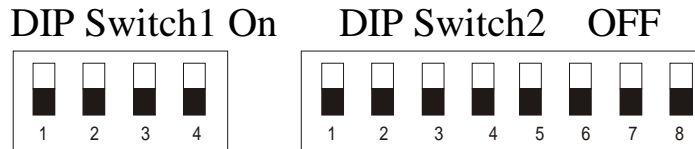

POS76 II -D

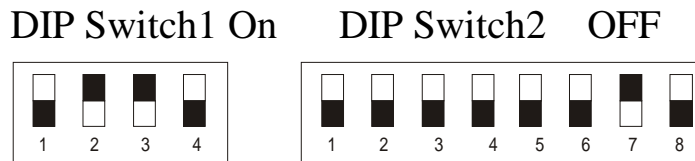

If change the setting of DIP switch, need to open the iron plate at the bottom of the printer.

## Part 3 Print Control Command

### 3.1 Summary

POS76II offers ESC/POS print command set, FS Chinese print commands. Each command is described in following format:

| Print Command  | Function                              |
|----------------|---------------------------------------|
| Format: ASCII: | the standard ASCII character sequence |
| Decimal:       | the decimal numbers sequence          |
| Hexadecimal:   | the hexadecimal number sequence       |

Explanation: what the command does and how to use it.

Example: some examples are listed to illustrate the command for better understanding.

### 3.2 Command Specifications

#### 3.2.1 Character control commands

| ESC SP         | Set character right spacing |    |   |
|----------------|-----------------------------|----|---|
| Format: ASCII: | ESC                         | SP | n |
| Decimal:       | 27                          | 32 | n |
| Hexadecimal:   | 1B                          | 20 | n |

Explanation:

Its unit is half dot, set character right spacing to n half-dots.

n=0~32

---

Default n=0

**ESC !** **Set character print mode**

---

|         |              |     |    |   |
|---------|--------------|-----|----|---|
| Format: | ASCII:       | ESC | !  | n |
|         | Decimal:     | 27  | 33 | n |
|         | Hexadecimal: | 1B  | 21 | n |

---

Explanation:

ESC ! n is a comprehensive command to set character print mode, is used for selecting print character size and underline. Each bit of print parameter is defined as:

| Bit | Function            | Value    |         |
|-----|---------------------|----------|---------|
|     |                     | 0        | 1       |
| 0   | Character Selection | 5×7      | 7×7     |
| 1   | Undefined           |          |         |
| 2   | Undefined           |          |         |
| 3   | Undefined           |          |         |
| 4   | Double height       | Disabled | Enabled |
| 5   | Double height       | Disabled | Enabled |
| 6   | Undefined           |          |         |
| 7   | Underline           | Disabled | Enabled |

Default: n=0, namely select 5×7 dots, normal character size, no underline.  
Notice: should select single directional print mode firstly, then can carry on double height print.

**ESC %** **Select/Cancel User-defined Characters**

---

|         |              |     |    |   |
|---------|--------------|-----|----|---|
| Format: | ASCII:       | ESC | %  | n |
|         | Decimal:     | 27  | 37 | n |
|         | Hexadecimal: | 1B  | 25 | n |

---

Explanation:

Parameter n is one byte, only the LSB is valid.

When n=<\*\*\*\*\*1>B, select user-defined character set;

When n=<\*\*\*\*\*0>B, select normal character set.

0≤n≤255, default n=0

**ESC &** **Define User-defined Characters**

---

|         |              |       |   |   |   |                                  |
|---------|--------------|-------|---|---|---|----------------------------------|
| Format: | ASCII:       | ESC & | s | n | m | [a,P1,P2,⋯Ps×a] <sub>m-n+1</sub> |
|         | Decimal:     | 27 38 | s | n | m | [a,P1,P2,⋯Ps×a] <sub>m-n+1</sub> |
|         | Hexadecimal: | 1B 26 | s | n | m | [a,P1,P2,⋯Ps×a] <sub>m-n+1</sub> |

---

Explanation:

ESC & is used to define m-n+1 users-defined characters.

S specifies the number of bytes in the vertical direction.  $s=1$ .  
 N, m denote the starting character code and ending character code respectively, from  $\langle 20 \rangle H$  to  $\langle 7E \rangle H$ , the maximum number of user-defined character code is 95.  $32 \leq n \leq m \leq 126$ .

A denotes the number of dots in horizontal direction,  $0 \leq a \leq 6$  ( $5 \times 7$  dots),  
 $0 \leq a \leq 10$  ( $7 \times 7$  dots).

$P_1, p_2, \dots, p_a$  are the data code of each defined characters.

Example:

\*  $5 \times 7$  dots

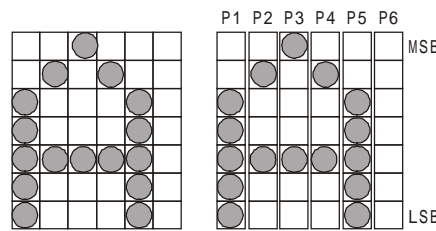

When the defined character codes are 20H:

|                             |    |    |    |    |    |    |    |    |    |    |
|-----------------------------|----|----|----|----|----|----|----|----|----|----|
| ESC                         | &  | s  | n  | m  | a  | p1 | p2 | p3 | p4 | p5 |
| Command codes <hexadecimal> |    |    |    |    |    |    |    |    |    |    |
| 1B                          | 26 | 01 | 20 | 20 | 05 | 3E | 48 | 88 | 48 | 3E |

\*  $7 \times 7$  dots

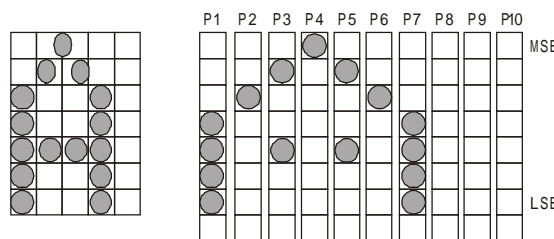

When the defined character codes are 20H:

|                             |    |    |    |    |    |    |    |    |    |    |    |    |
|-----------------------------|----|----|----|----|----|----|----|----|----|----|----|----|
| ESC                         | &  | s  | n  | m  | a  | p1 | p2 | p3 | p4 | p5 | p6 | p7 |
| Command codes <hexadecimal> |    |    |    |    |    |    |    |    |    |    |    |    |
| 1B                          | 26 | 01 | 20 | 20 | 07 | 1E | 20 | 48 | 80 | 48 | 20 | 1E |

| ESC t   | Select Character Set |     |     |   |
|---------|----------------------|-----|-----|---|
| Format: | ASCII:               | ESC | t   | n |
|         | Decimal:             | 27  | 116 | n |
|         | Hexadecimal:         | 1B  | 74  | n |

Explanation:

Select character set 0 or 1.  $n=0 \sim 1$ .

Default:  $n=0$ , select character set 0 (IBM character set II)

### 3.2.2 Print Position Control Commands





This command is only valid to current line print, does not change the line spacing value set by ESC 2, ESC 3 commands.

---

**ESC K n** **Print and Return Paper n/144 inch**

|         |              |     |    |   |
|---------|--------------|-----|----|---|
| Format: | ASCII:       | ESC | K  | n |
|         | Decimal:     | 27  | 75 | n |
|         | Hexadecimal: | 1B  | 4B | n |

Explanation:

Print the data in the buffer and return paper n/144 inch (n×0.176mm)  
n=0~255

---

**ESC d** **Print and Feed paper n Character Lines**

|         |              |     |     |   |
|---------|--------------|-----|-----|---|
| Format: | ASCII:       | ESC | d   | n |
|         | Decimal:     | 27  | 100 | n |
|         | Hexadecimal: | 1B  | 64  | n |

Explanation:

Print the data in the buffer and feed paper n character lines. n=0~255.

---

**ESC e n** **Print and Feed Paper n Character Lines**

|         |              |     |     |   |
|---------|--------------|-----|-----|---|
| Format: | ASCII:       | ESC | e   | n |
|         | Decimal:     | 27  | 101 | n |
|         | Hexadecimal: | 1B  | 65  | n |

Explanation:

Print the data in the buffer and return paper n character lines. n=0~255.

---

**ESC 2** **Set Character Line Spacing to 1/6 inch**

|         |              |     |    |
|---------|--------------|-----|----|
| Format: | ASCII:       | ESC | 2  |
|         | Decimal:     | 27  | 50 |
|         | Hexadecimal: | 1B  | 32 |

Explanation:

Set character line to 1/6 inch.

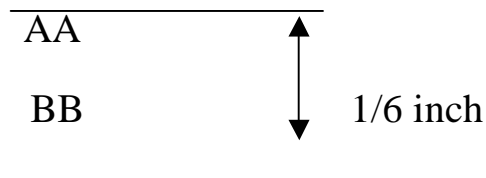

---

**ESC 3** **Set line spacing to n dot lines (n / 203 inch)**

---

|         |              |     |    |
|---------|--------------|-----|----|
| Format: | ASCII:       | ESC | 2  |
|         | Decimal:     | 27  | 51 |
|         | Hexadecimal: | 1B  | 33 |

---

Explanation:

Set line spacing to  $n/144$  inch. =0~255.

The initial default of the printer is  $n=24$  (1/6 inch) .

| ESC D   |              |       |      | Set Horizontal Tab Value |  |
|---------|--------------|-------|------|--------------------------|--|
| Format: | ASCII:       | ESC D | [n]k | NUL                      |  |
|         | Decimal:     | 27 68 | [n]k | 0                        |  |
|         | Hexadecimal: | 1B 44 | [n]k | 00                       |  |

---

Explanation:

Set horizontal tab position to  $n_1, n_2, \dots, n_k$ .

$k=1 \sim 32$ , that means you can set 32 horizontal positions at most.

All horizontal tab positions ( $n_i$ ) are within the line width allowed by the printer, when choosing  $5 \times 7$  dots mode,  $n$  maximum is 35, when choosing  $7 \times 7$  dots mode,  $n$  maximum is 42.

Horizontal tab position is stored by being calculated into absolute dot position according to current character  $5 \times 7$  dots,  $7 \times 7$  dots, or Chinese character  $15 \times 16$  dots mode (including character spacing), so, the width of double-width characters should be twice of the width of normal characters. After carried out ESC D command, it no longer influences the tab position that has been already set if change the category and size of characters, so as to ensure that Chinese characters and characters can be mixed in one line, or enlarge and dwindle the characters horizontally, the tab can still be orderly while using.

NUL is added at the end, denotes this command is over.

ESC D NUL command is used to clear all horizontal tab positions, and HT command is invalid that be carried out later.

Notice:  $n_k > n_{k-1}$  is necessary, if  $n_k < n_{k-1}$ , printer will think this command has already been over, the following command parameter will be considered to be normal printing data.

| ESC U   |              | Cancel/Select Single Directional Print |    |   |
|---------|--------------|--|----|---|
| Format: | ASCII:       | ESC                                    | U  | n |
|         | Decimal:     | 27                                     | 85 | n |
|         | Hexadecimal: | 1B                                     | 55 | n |

---

Explanation:

Select/cancel single directional print.  $n=0\sim 255$ , only the lowest bit is valid.

When  $n=\langle \text{*****}1 \rangle B$ , Select single directional print;

When  $n=\langle \text{*****}0 \rangle B$ , Select bi-directional print;

Default:  $n=0$ .

Notice: When in bi-directional print mode, the print speed is faster than that in single directional mode, but may appear the phenomenon that it is not neat correctly from head to foot, this is caused by its own principle of the printer's structure, belonging to normal phenomenon.

### 3.2.3 Graphics commands

ESC \* Set Bit-map Graphics Print

|         |              |     |    |   |    |    |         |           |
|---------|--------------|-----|----|---|----|----|---------|-----------|
| Format: | ASCII:       | ESC | *  | m | n1 | n2 | [d1,d2] | n1+256×n2 |
|         | Decimal:     | 27  | 42 | m | n1 | n2 | [d1,d2] | n1+256×n2 |
|         | Hexadecimal: | 1B  | 2A | m | n1 | n2 | [d1,d2] | n1+256×n2 |

Explanation:

$m=0,1$ .  $0\leq n1\leq 255$ ,  $0\leq n2\leq 3$ ,  $0\leq d\leq 255$ 。

$n1, n2$  are two-bits of hexadecimal number,  $n1$  is the low byte,  $n2$  is high byte, denote the width of printing graphics set by ESC commanded, the number of dots is within the maximum line-width dots number of the printer.

When  $m=0$ , select normal print, maximum print dots number is 210.

When  $m=1$ , select half dot print, maximum print dots number is 420.

At this moment the adjacent two dots of each dot-line can't be 1.

Definition for  $d$  is:

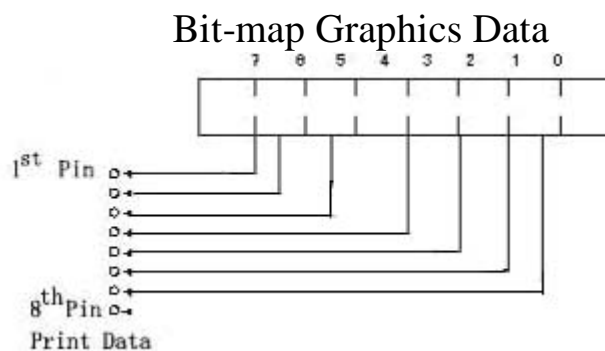

Notice:

1. Please select single directional print mode with ESC U command before printing the bit-map graphics.
2. Allow printing bit-map graphics and characters in the same line.

### 3.2.4 Chinese Character Commands

**FS !** Set Chinese Print Mode

|         |              |    |    |   |
|---------|--------------|----|----|---|
| Format: | ASCII:       | FS | !  | n |
|         | Decimal:     | 28 | 33 | n |
|         | Hexadecimal: | 1C | 21 | n |

Explanation:

Set Chinese print mode. It is valid only in standard mode. n=0~255.

Each bit of n is defined as the following:

| Bit      | Function            | Value  |        |
|----------|---------------------|--------|--------|
|          |                     | 0      | 1      |
| 0,1,2,3, | Undefined           | ---    | ---    |
| 4        | Double height print | Cancel | Select |
| 5        | Double width print  | Cancel | Select |
| 6,7      | Undefined           | ---    | ---    |

**FS W n** Select/Cancel Chinese Quadruple Mode Print

|         |              |    |    |   |
|---------|--------------|----|----|---|
| Format: | ASCII:       | FS | W  | n |
|         | Decimal:     | 28 | 87 | n |
|         | Hexadecimal: | 1C | 57 | n |

Explanation: When the lowest bit of n is 0, cancel Chinese quadruple mode print; when the lowest bit of n is 1, select Chinese quadruple mode print.

**FS &** Select Chinese Print Mode

|         |              |    |    |
|---------|--------------|----|----|
| Format: | ASCII:       | FS | &  |
|         | Decimal:     | 28 | 38 |
|         | Hexadecimal: | 1C | 26 |

Explanation:

After received this command, the printer will finish printing current line, and will switch to Chinese print mode from the next line.

In Chinese print mode, the Chinese character codes received by printer are 2-byte standard internal codes (all larger than 9FH codes), look for hard Chinese characters of the printer according to these codes, print GB Chinese characters of 15×16 dots.

When the printer receives ASCII codes (20H-9FH) of single byte, it will print out corresponding characters of 8×16 dots.

ESC is still available under Chinese print mode! It is to set character print mode.

**Notice: Should use ESC U command to select single directional print mode firstly, the print quality will be better for the Chinese characters.**

| FS .    |              | Cancel Chinese Print Mode |    |
|---------|--------------|---------------------------|----|
| Format: | ASCII:       | FS                        | .  |
|         | Decimal:     | 28                        | 46 |
|         | Hexadecimal: | 1C                        | 2E |

Explanation:

After received this command, the printer will cancel Chinese print mode and turn to normal ASCII character print mode.

| FS 2 C1 C2 d1...dk |              | User-defined Chinese Characters |    |    |    |         |
|--------------------|--------------|---------------------------------|----|----|----|---------|
| Format:            | ASCII:       | FS                              | 2  | c1 | c2 | d1...dk |
|                    | Decimal:     | 28                              | 50 | c1 | c2 | d1...dk |
|                    | Hexadecimal: | 1C                              | 32 | c1 | c2 | d1...dk |

Explanation:

c1=FEH

c2=A1H-FEH

k=32

c1, c2 denote the codes for user-defined Chinese characters.

Data Format

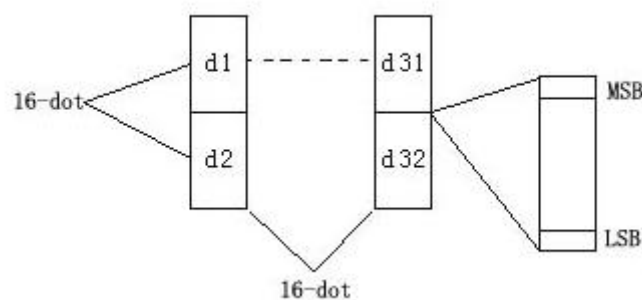

| FS ? c1 c2 |              | Cancel User-defined Chinese Characters |    |    |    |
|------------|--------------|--|----|----|----|
| Format:    | ASCII:       | FS                                     | ?  | c1 | c2 |
|            | Decimal:     | 28                                     | 63 | c1 | c2 |
|            | Hexadecimal: | 1C                                     | 3F | c1 | c2 |

Explanation:

c1=FEH

c2=A1H-FEH

---

| FS S n1 n2 |              | Set Chinese Character Left and Right Spacing |    |    |    |
|------------|--------------|--|----|----|----|
| Format:    | ASCII:       | FS   | S  | n1 | n2 |
|            | Decimal:     | 28   | 83 | n1 | n2 |
|            | Hexadecimal: | 1C   | 53 | n1 | n2 |

---

Explanation:

Set Chinese character left spacing. n1=0~32, default n1=0

Set Chinese character right spacing. n2=0~32, default n2=0

When using ESC! <0> to select character A (5×7 whole dot character) , utilize ESC SP <4> command to make the dot width of a Chinese character equal the one of a whole dot ASCII character.

When using ESC! <1> to select character B (7×7 half dot character) , utilize FS S <0><4> command to make the dot width of a Chinese character equal the one of two half dots ASCII character.

### 3.2.5 Black Mark Control Commands

| GS ( F pL pH a m nL nH |              | Set the Offset of Black Mark Localization |    |    |    |    |   |   |    |    |
|------------------------|--------------|---|----|----|----|----|---|---|----|----|
| Format:                | ASCII:       | GS  | (  | F  | pL | pH | a | m | nL | nH |
|                        | Decimal:     | 29  | 40 | 70 | pL | pH | a | m | nL | nH |
|                        | Hexadecimal: | 1D  | 28 | 46 | pL | pH | a | m | nL | nH |

---

Explanation:

This command is used to choose black mark localization control permission, and set the offset of cutting/tearing paper position or initial print position relative to black mark test position. This value is calculated in dots number mode.

The relevant parameters of this command are:

$pL + (pH \times 256) \leq 4$  namely  $pL=4$ ,  $pH=0$

$1 \leq a \leq 2$

$m=0, 48$

$0 \leq (nL+nH \times 256) \leq 1700$

- a is used to set the offset of cutting/tearing paper position or initial print position.

| A | Function  |
|---|---|
| 1 | Set the offset of initial print position relative to black mark test position         |
| 2 | Set the offset of cutting/tearing paper position relative to black mark test position |

- 
- $m = 0$  or 48, select the offset as calculation for ongoing paper direction.
  - The corresponding real distance of offset that set by  $nL$ ,  $nH$  is  $(nL + nH \times 256) \times 0.176\text{mm}$ ;
  - only after carried out these commands, then the related black mark localization operation that commanded by GS FF and GS V is valid;
  - Set the offset of initial print position ( $a=1$ ) valid while carrying out GS FF command;
  - Set the offset of cutting/tearing paper position ( $a=2$ ) valid while carrying out GS V m command;
  - Default  $nL = nH = 0$ , that is, when black mark test switch tested black mark, current corresponding print head position on the receipt is the set initial print position; and current corresponding cutting/tearing paper end position on the receipt is the set cutting/tearing paper position.
  - Calculation explanation about the offset of cutting/tearing paper position and initial print position:
    1. When the distance  $L$  from cutting/tearing paper position to black mark print position is same to the inherent mechanical value  $L_0$  of the printer's structure, furthermore, the distance  $Q$  from cutting/tearing paper position to initial print position is same to the inherent mechanical value  $Q_0$  of the printer's structure (as Fig. 1 shows), all the offsets set by GS ( F command are 0.
    2. When the distance  $L$  from black mark print position to cutting/tearing paper position is smaller than the mechanical value of the printer  $L_0$  (as Fig. 2 shows), the offset of cutting/tearing paper position commanded by GS ( F is calculated as: the offset of tearing paper position  $= (L_0 - L) / 0.176$  (dots number)  
 When the distance  $L$  from black mark print position to cutting/tearing paper position is larger than the mechanical value of the printer  $L_0$  (as Fig. 3 shows), the offset of cutting/tearing paper position commanded by GS ( F is calculated as: the offset of cutting/tearing paper position  $= (L_0 + \text{the distance between the two adjacent black marks} - L) / 0.176$  (dots number)  
 Notice: When setting the offset of cutting/tearing paper position, the parameter of GS ( F command  $a$  should be 2.
    3. When the offset of cutting/tearing paper position is not 0 or the distance  $Q$  from the initial print position to cutting/tearing paper position is larger than the mechanical value of the printer ( $Q_0$ ) (as Fig. 4 shows) for each



receipt,

the offset of cutting/tearing paper position commanded by GS ( F is calculated as: the offset of initial print position =  $(Q-Q_0) / 0.176$ (dots number)

Notice: When setting the offset of initial print position, the parameter of GS ( F command a should be 1.

4. The inherent mechanical value of the printer structure M-U110

$L_0 = A_{mm}$

$Q_0 = C_{mm}$  (refer to 2.4.3)

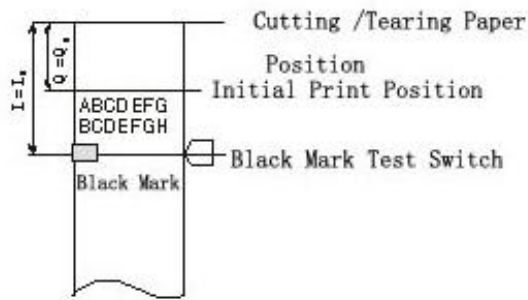

Fig 1

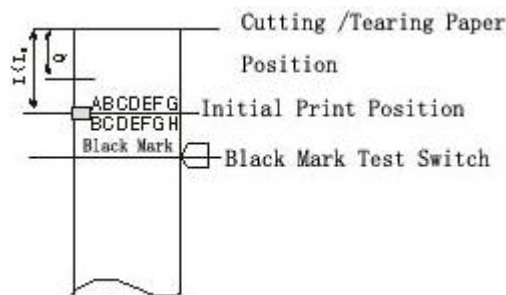

Fig 2

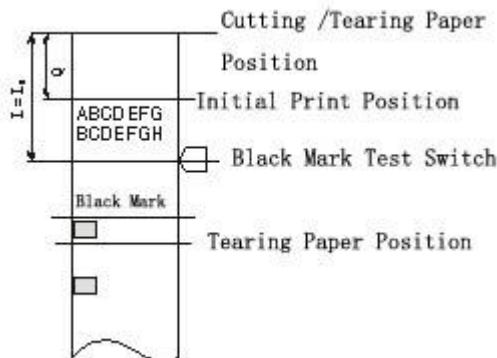

Fig 3

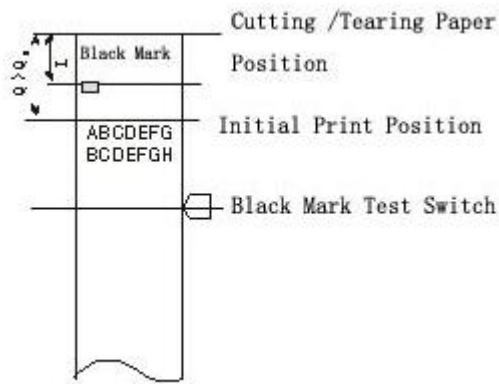
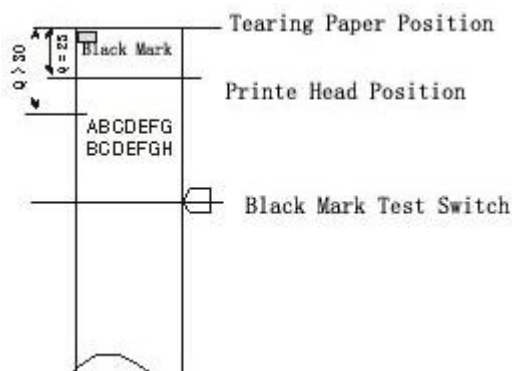

Fig 4

Example for the usage of the black mark localization control command regarding to specified print receipt. (taking D model printer as an example ) that is  $L_0=51\text{mm}$ ,  $Q_0=23\text{mm}$ .

Requests for receipt example 1: tearing paper position should at the printing black mark position,  
The initial print position for every receipt should be at 30mm to the tearing paper position.



- Calculation for the offset of tearing paper position  
As the black mark is at the position of tearing paper, that is  $L=0$ , so the offset of tearing paper position= $(53-0) / 0.176=303$  dots
- Using the following command to set the offset of Cutting/Tearing paper position  
GS (F<4><0><2><0><45><1>
- Calculation for the offset of initial print position  
 $(30-23) / 0.176= 40$  dots
- Using the following command to set the offset of initial print position  
GS ( F<4><0><1><0><40><0>
- After finishing the aforesaid settings, when print every receipt: feed the paper to the initial print position with GS FF command; send the data for every receipt that need to print, and print these data line-to-line; feed paper to tearing paper position with GS V m command, and tear off the

receipt.

Requests for receipt example 2: the distance from tearing paper position to black mark should be 8mm,

The distance from the initial print position to tearing paper position should be 23mm.

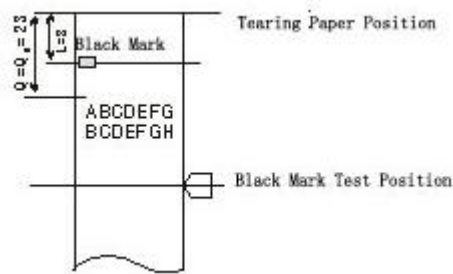

- Calculation for the offset of tearing paper position  
As the black mark is at the position of tearing paper line  $<L_0 (51\text{mm})$ ,  
so  
the offset of tearing paper position  $= (51 - 8) / 0.176 = 244$  dots
- Using the following command to set the offset of cutting/tearing paper  
GS ( F<4><0><2><0><244><1>
- Calculation for the offset of initial print position  
 $(23 - 23) / 0.176 = 0$  dot
- Using the following command to set the offset of initial print position  
GS ( F<4><0><1><0><0><0>
- After finishing the aforesaid setting, when print every receipt, the command to be used is the same as example 1.

Requests for receipt example 3: the length of receipt: 150mm

The distance from tearing paper position to black mark should be 142mm,

The distance from the initial print position to tearing paper position should be 39mm.

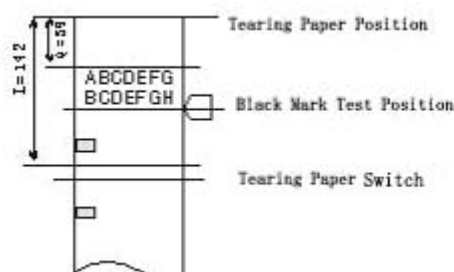

- Calculation for the offset of tearing paper position  
As the black mark is at the position of tearing paper line  $>L_0 (51\text{mm})$ ,  
so the offset of tearing paper position  $= (51 + 150 - 142) / 0.176 = 335$  dots

- Using the following command to set the offset of tearing paper  
GS ( F<4><0><2><0><79><1>
- Calculation for the offset of initial print position  
(39-23) 0.176=91 dots
- Using the following command to set the offset of initial print position  
GS ( F<4><0><1><0><91><0>
- After finishing the aforesaid setting , when print every receipt the command to be used is the same as example 1.

Notice:

1. Under the situation that the offset of tearing paper position and initial print position both are 0, it is possible to finish the localization print of each receipt by using GS V m command only.
2. So long as the offset of tearing paper position is not 0, it needs to set the offset of tearing paper position (a=2) and the offset of initial print position (a=1) respectively by using GS ( F command.
3. Only after have set the initial print position, the paper can be fed to the initial print position by using GS FF, otherwise may appear the situation that the localization is inaccurate or empty a receipt.
4. When altered the offset that have been set last time with GS (F command, may appear the situation that the localization is inaccurate or empty a receipt when print the first receipt, but the receipt that will print afterwards is correct.

| GS FF   |              | Send Black Mark Paper to Initial Print Position |    |
|---------|--------------|---|----|
| Format: | ASCII:       | GS  | FF |
|         | Decimal:     | 29  | 12 |
|         | Hexadecimal: | 1D  | 0C |

Explanation:

This command is valid only under the condition allowed by black mark localization control. Test black mark and feed the paper forwards to the initial print position that set by GS ( F(a=1) command. When the black mark paper is already at the current initial print position, then don't feed paper.

---

**GS V m      Select Paper Cutting Method and Cut Paper, Feed Paper**

---

|         |              |    |    |   |   |
|---------|--------------|----|----|---|---|
| Format: | ①ASCII:      | GS | V  | m |   |
|         | Decimal:     | 29 | 86 | m |   |
|         | Hexadecimal: | 1D | 56 | m |   |
|         | ②ASCII:      | GS | V  | m | n |
|         | Decimal:     | 29 | 86 | m | n |
|         | Hexadecimal: | 1D | 56 | m | n |

---

Explanation:

$$0 \leq n \leq 255$$

This command supports two kinds of paper cutting method.

When m=0, 1, 48, 49, the printer carries out direct paper cutting. ( whole cutting or partial cutting).

When m=66, the printer presents paper first (cutting/tearing paper line position +n\*0.176mm), then cuts paper.

Realizing whole paper cutting or half paper cutting is selected by DIP setting. ( refer to 2.6 DIP setting)

This command is valid only under the condition that the print position is at the beginning of line.

If black mark localization selection is valid, then n value is invalid when carrying out GS V 66 command, the distance for presenting paper onwards is confirmed by the parameter that set by GS (F command. (Refer to 2.5.3).

---

**GS r n      Transmit Status**

---

|         |              |    |     |   |
|---------|--------------|----|-----|---|
| Format: | ASCII:       | GS | r   | n |
|         | Decimal:     | 29 | 114 | n |
|         | Hexadecimal: | 1D | 72  | n |

---

Explanation:

This command is used to transmit one byte current status of printer to the host (only valid for the printer with serial interface).

| N    | Function                             |
|------|--------------------------------------|
| 1,49 | transmit status of paper test switch |
| 2,50 | transmit status of cash drawer       |

When n=1, 49, the byte contents of transmitted status are:

| Bit  | Status                                 | Value off/on |               |
|------|--|--------------|---------------|
|      |  | 0            | 1             |
| 0, 1 | The status of paper running out switch | With paper   | Without paper |
| 2, 3 | The status of paper end switch         | With paper   | Without paper |
| 4    | Not in use                             | 0            | -             |
| 5, 6 | Undefined                              | -            | -             |
| 7    | Not in use                             | 0            | -             |

When n=2, 50, the byte contents of transmitted status are:

| Bit  | Status                         | Value off/on |      |
|------|--------------------------------|--------------|------|
|      |                                | 0            | 1    |
| 0    | The status of cash drawer pin3 | LOW          | HIGH |
| 2, 3 | Undefined                      | -            | -    |
| 4    | Not in use                     | 0            | -    |
| 5, 6 | Undefined                      | -            | -    |
| 7    | Not in use                     | 0            | -    |

The printer will transmit the status bytes only when it tested that the DSR signal of the host is valid, otherwise will be waiting for all the time. The host transmitting the command is by sending it to the print buffer of the printer, and wait for the printer carrying out in order. So it will take more time for printer to transmit the status than the time it needed for receiving the command and transmitting the status, the time interval is relevant with that how much data needed to deal with in the print buffer and how much time needed to carry out correlative operation.

### 3.2.6 Other Commands

**ESC @** Initialize Printer

|         |              |     |    |
|---------|--------------|-----|----|
| Format: | ASCII:       | ESC | @  |
|         | Decimal:     | 27  | 64 |
|         | Hexadecimal: | 1B  | 40 |

Explanation:

ESC @ command is to initialize the following contents of the printer:

- Clear the data in the print buffer ;
- Restore the default of each print command.

---

| ESC c 3 n |              | Select Paper Running Out Tester |    |    |   |
|-----------|--------------|---------------------------------|----|----|---|
| Format:   | ASCII:       | ESC                             | c  | 3  | n |
|           | Decimal:     | 27                              | 99 | 51 | n |
|           | Hexadecimal: | 1B                              | 63 | 33 | n |

---

**Explanation:**

Select / cancel that paper running out tester sends out the signal while it tested paper is about to use up.

n=0~255 Only the lowest bit is valid.

When n=1, send out the signal while tested paper is about to use up.

When n=0, don't send out the signal while tested paper is about to use up.

---

| ESC c 4 |              | Set Stopping Print When Paper End |    |    |   |
|---------|--------------|-----------------------------------|----|----|---|
| Format: | ASCII:       | ESC                               | c  | 4  | n |
|         | Decimal:     | 27                                | 99 | 52 | n |
|         | Hexadecimal: | 1B                                | 63 | 34 | n |

---

**Explanation:**

Select / cancel stopping print while paper tester tested paper end.

n=0~255 Only the lowest bit is valid.

When n=<\*\*\*\*\*1>B, stop printing while paper tester tested paper end;

When n=<\*\*\*\*\*0>B, don't stop printing while paper tester tested paper end, so that users can print the last one receipt to the bottom of page.

Default n =1

---

| ESC c 5 |              | Enable/Disable Button |    |    |   |
|---------|--------------|-----------------------|----|----|---|
| Format: | ASCII:       | ESC                   | c  | 5  | n |
|         | Decimal:     | 27                    | 99 | 53 | n |
|         | Hexadecimal: | 1B                    | 63 | 35 | n |

---

**Explanation:**

Enable/disable all the buttons on the panel.

n=0~255, only the lowest bit is valid.

When n=<×××××××0>B, enable paper feeding button.

When n=<×××××××1>B, disable paper feeding button.

Default n =0

---

| ESC p   |              | Cash Drawer Control |     |   |    |    |
|---------|--------------|---------------------|-----|---|----|----|
| Format: | ASCII:       | ESC                 | p   | m | nl | n2 |
|         | Decimal:     | 27                  | 112 | m | nl | n2 |
|         | Hexadecimal: | 1B                  | 70  | m | nl | n2 |

---

**Explanation:**

This command is to generate a pulse to trigger the opening and closing of

the cash drawer,  $n_1$ ,  $n_2$  define the duration of the trigger pulse.

$m=0, 0 < n_1 \leq n_2 \leq 255$ 。

Opening time is  $n_1 \times 2\text{ms}$ , closing time is  $n_2 \times 2\text{ms}$ .

| <u>ESC v</u> |              | <u>Transmit Status of Printer</u> |     |
|--------------|--------------|-----------------------------------|-----|
| Format:      | ASCII:       | ESC                               | v   |
|              | Decimal:     | 27                                | 118 |
|              | Hexadecimal: | 1B                                | 76  |

Explanation:

Transmit the status of printer to the host.

When printer received this command, it transmits one byte through the serial interface TXD to the host.

Definition of said byte is shown as following:

| Bit | Function     | Value      |               |
|-----|--------------|------------|---------------|
|     |              | 0          | 1             |
| 0   | Undefined    | ----       | ----          |
| 1   | Undefined    | ----       | ----          |
| 2   | Paper tester | With paper | Without paper |
| 3   | Undefined    | ----       | ----          |
| 4   | Not in use   | 0          | 0             |
| 5   | Undefined    | ----       | ----          |
| 6   | Undefined    | ----       | ----          |
| 7   | Undefined    | ----       | ----          |

| <u>ESC u</u> |              | <u>Transmit Status of Equipment</u> |     |   |
|--------------|--------------|-------------------------------------|-----|---|
| Format:      | ASCII:       | ESC                                 | u   | n |
|              | Decimal:     | 27                                  | 117 | n |
|              | Hexadecimal: | 1B                                  | 75  | n |

Explanation:

Transmit status of the peripheral equipment to the host:

Default  $n = 0$

When printer received this command, it transmits one byte through the serial interface TXD to the host.

| Bit | Function | Value |   |
|-----|----------|-------|---|
|     |          | 0     | 1 |
|     |          |       |   |



|   |                        |      |      |
|---|------------------------|------|------|
| 0 | Cash drawer on/off pin | Low  | High |
| 1 | Undefined              | ---- | ---- |
| 2 | Undefined              | ---- | ---- |
| 3 | Undefined              | ---- | ---- |
| 4 | Not in use             | 0    | ---- |
| 5 | Undefined              | ---- | ---- |
| 6 | Undefined              | ---- | ---- |
| 7 | Undefined              | ---- | ---- |

|            |              |                                    |    |
|------------|--------------|------------------------------------|----|
| <u>ESC</u> | <u>&lt;</u>  | <u>Restore Print Head Position</u> |    |
| Format:    | ASCII:       | ESC                                | <  |
|            | Decimal:     | 27                                 | 60 |
|            | Hexadecimal: | 1B                                 | 3C |

**Explanation:**

This command is used to restore print head, when printer received the command, it moves the print head to the left initial print position

## Part 4 Caution for using

- 4.1 Be sure use the preprinted black mark paper that meet the specifications and provided or confirmed by the printer supplier, otherwise will lower the print quality and shorten the print head life.  
Pay attention to the density of print paper roll, and the minimum inner diameter should accord with the error demand, otherwise may appear the phenomenon that paper feeding is not smooth and straight and so on, and will influence the printer working normally.  
Pay attention to the black mark print quality, otherwise may influence the precision of black mark localization control.
- 4.2 When connecting or disconnecting the power supply cable to the printer, make sure the power is turned off and is not plugged into AC electrical socket. Otherwise it may damage the power supply or the printer.
- 4.3 Shouldn't fetch the paper scrap and other adherent things in the print head with hard objects (such as the tweezers, razor blade and so on ), in case that cause permanent damage to the print head.
- 4.4 After finishing print, if open the printer's cover, shouldn't touch the print head or the driver outer cover with hands at once, in case that scalded by the metal outer cover with high-temperature.

## Appendix Index of Print characters

|          |   |   |   |   |    |   |   |   |   |   |   |   |   |   |   |   |
|----------|---|---|---|---|----|---|---|---|---|---|---|---|---|---|---|---|
| 十六<br>进制 | 0 | 1 | 2 | 3 | 4  | 5 | 6 | 7 | 8 | 9 | A | B | C | D | E | F |
| 2        |   | ! | " | # | \$ | % | & | ' | ( | ) | * | + | , | - | . | / |
| 3        | 0 | 1 | 2 | 3 | 4  | 5 | 6 | 7 | 8 | 9 | : | ; | < | = | > | ? |
| 4        | ⊙ | A | B | C | D  | E | F | G | H | I | J | K | L | M | N | O |
| 5        | P | Q | R | S | T  | U | V | W | X | Y | Z | [ | \ | ] | ^ |   |
| 6        | ' | a | b | c | d  | e | f | g | h | i | j | k | l | m | n | o |
| 7        | p | q | r | s | t  | u | v | w | x | y | z | { |   | } | ~ |   |
| 8        | ç | ü | é | â | ä  | ñ | ë | ç | ê | é | è | í | î | ã | ä | å |
| 9        | é | ê | ë | ö | ü  | ó | ù | ú | û | ü | ÿ | É | Ê | Ë | Ü | Ý |