



**FIELDMANN**<sup>®</sup>  
Home & Garden Performance



FDV 1002-A

---

English ..... 5  
 Čeština ..... 23  
 Slovenčina ..... 41  
 Magyarul ..... 59  
 Polski ..... 77  
 Русский ..... 95



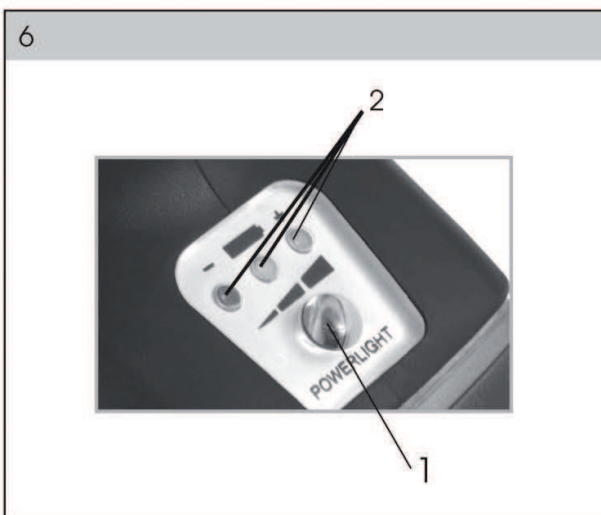
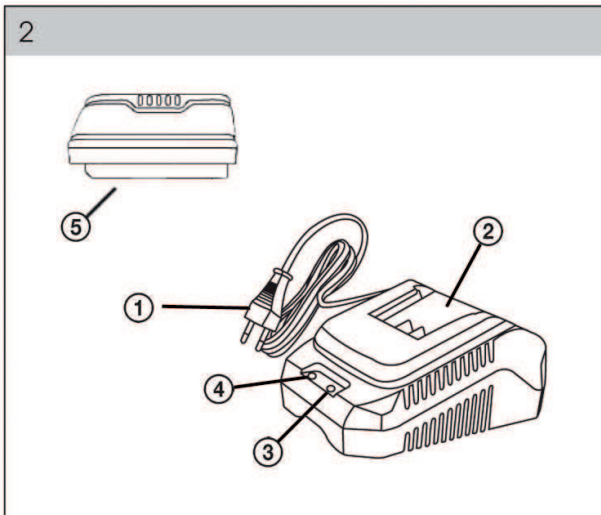

# Cordless Drill

## USER'S MANUAL

**Thank you for purchasing this cordless drill. Before you start using it, please, carefully read this user's manual and save it for possible future use.**

## CONTENTS

ILLUSTRATED ATTACHMENT .....	3
1. GENERAL SAFETY REGULATIONS .....	6
Important safety notices	
Packaging	
Operating instructions	
2. SYMBOLS .....	8
3. MACHINE DESCRIPTION AND INCLUDED CONTENTS .....	9
Machine description	
Supplied contents	
4. PUTTING INTO OPERATION .....	9
Charging the machine	
Drill chuck	
Torque control	
Turning on/off	
5. INSTRUCTIONS FOR PROPER USE .....	11
Screwing	
Drilling	
LED Battery charge level indicator light	
Lighting of the working area	
Overload	
More advice about drilling	
6. OPERATING INSTRUCTIONS .....	12
Operation	
Purpose of use	
Instructions for use	
Electrical safety	
Safety instructions for the battery and charger	
7. MAINTENANCE AND STORAGE .....	16
Maintenance	
Storage	
8. TECHNICAL SPECIFICATIONS .....	18
9. DISPOSAL .....	19
10. DECLARATION OF CONFORMITY .....	20

# 1. GENERAL SAFETY INSTRUCTIONS

## Important Safety Instructions

- ✿ Read the Instruction Manual attentively before use.
- ✿ Carefully remove the tool and any accessories from the box. Do not discard any of the packing materials until all parts are accounted for.
- ✿ Keep the product in a dry place.
- ✿ Read all warnings and instructions attentively. Failure to follow all warnings and instructions listed below may result in electric shock, fire and/or serious personal injury.
- ✿ Read operator's manual carefully. Learn its applications and limitations, as well as the specific potential hazards related to this power tool. Following this rule will reduce the risk of electric shock, fire, or serious injury.
- ✿ Check whether the available power supply parameters correspond to the voltage parameters specified on the tool.
- ✿ Check whether the power tool and connections are not damaged.
- ✿ Connect the power cord to the outlet only when the tool is switched off.
- ✿ Switch on the tool prior you place it on the workpiece.
- ✿ Take all safety measures to reduce a risk of electric shock. Avoid body contact with earthed or grounded surfaces, such as pipes, radiators, ranges and refrigerators.
- ✿ Sudden temperature changes may result in water condensation on live parts. Prior to use: Let the power tool reach the workplace room temperature.
- ✿ Do not use machines, tools and recommended accessories for any than intended purposes!
- ✿ Clamp the workpiece safely. Secure the workpiece to be drilled in a vice or with clamps to keep it from turning as the drill bit rotates.
- ✿ Dress properly. Do not wear loose clothing or jewellery. Loose clothes, jewellery or long hair can be caught in moving parts. Wear safety shoes and gloves. Contain long hair.
- ✿ Should dust, chips and sawdust result from your activity or should you work above your head, always wear safety goggles and dust mask, where appropriate.
- ✿ While impact drilling, wear suitable ear protective equipment.
- ✿ While working on ladders, scaffolding or upper floors, always stand on a firm base.
- ✿ Do not expose power tools to rain or wet conditions. Do not immerse the tool into water.
- ✿ When operating a power tool outdoors, use an extension cord and other accessories suitable for outdoor use.
- ✿ Do not operate power tools in explosive atmospheres.
- ✿ When the tool is handed over to the third person, the Instruction Manual shall always be included.
- ✿ The power tool can be repaired only by a qualified specialist and with the original spare parts.

**⚠ WARNING!** Do not use a power tool while you are tired or under the influence of drugs, alcohol or medication. A moment of inattention while operating power tools may result in serious personal injury. Do not use the power tool in any of the following situations.

- ✿ Keep the power tool out of reach of children.
- ✿ Store idle power tools in the original package in a safe place and out of reach of children.
- ✿ Disconnect the power cord from the power outlet before making any adjustments, changing accessories, or storing power tools.
- ✿ Do not abuse the cord. Never use the cord to carry the charger. Do not pull the cord to disconnect the power tool from the power source.
- ✿ When working: Do not let the motor stop if the power tool is loaded.
- ✿ Keep the workplace clean and tidy. A messy workplace increases a risk of injury!
- ✿ Do not assume unusual body positions while drilling.
- ✿ Avoid unintentional power tool switching or startup.

## Packaging

The product is placed in a package preventing damage during transport. This package is a raw material therefore it can be handed-over for recycling.

## Instructions for use

Before beginning to work with the machine, read the following safety rules and instructions for use. Familiarize with operating elements and the proper use of the device. Keep the manual in a safe place for future reference. We recommend keeping the original package including the inner packaging materials, cash voucher and guarantee card for a period of warranty at minimum. For a case of transportation, pack the machine into the original box from the manufacturer, thus ensuring a maximum protection of the product during a possible transport (e.g. moving or sending into a service station).

 **Note:** If you hand the machine over to next persons, hand it over together with the manual. Adherence to the attached instructions for use is a precondition for the proper use of the machine. The operation manual includes also instructions for operation, maintenance and repairs.

**The manufacturer does not take any responsibility for accidents or damages resulting from the failure to adhere to this manual.**

## 2. SYMBOLS



The product complies with the applicable standards and regulations.



Read the Instruction Manual attentively prior to use.



Use eyes protective equipment



Use ears protective equipment

## 3. MACHINE DESCRIPTION AND INCLUDED CONTENTS

### Machine description (see pic. 1)

- A) Keyless chuck
- B) Torque setting ring
- C) Rotation direction switch for movement forward/back and neutral position safety switch
- D) Trigger switch
- E) Handle
- F) Battery charge level LED display and lighting of the working area
- G) Battery
- H) 2 speed switch

### Machine description (see pic. 2)

- 1) Battery adapter
- 2) Charger station with battery charging indicator (point. 3, 4)
- 5) Battery

### Supplied contents

Carefully take the machine out of the packaging and check whether all the following parts are present:

- ✿ Cordless drill with battery
- ✿ Battery charger station
- ✿ Bit - 1 pc
- ✿ User's manual

If there are parts missing or they are damaged, please contact the vendor from whom you bought the machine.

## 4. PUTTING INTO OPERATION

### Charging the machine

Proceed step by step according to the user's manual and use the pictures as a guide so that the assembly process is as easy as possible.

1. Take the battery out of the machine, press the release button and pull down to remove the battery.
2. Place the charger on a table near a power socket.
3. Properly insert the battery into the charger.

 **Note:** The battery may be inserted into the charger only in one way.

4. Connect the charger power cord to a power socket. At this time both the red and the green indicator light will be on.



5. As soon as the battery is fully charged, the green indicator light will stay on and the red indicator light will turn off.
6. After fully charging, disconnect the charger from the power socket. Before first use the battery must be fully charged.

For the first charge, it is recommended to charge the battery for 3-5 hours.

### **Drill chuck** (see pic. 3)

If you wish to open up the drill chuck, hold the rear part of the chuck and turn the front part of the chuck anticlockwise. Insert the desired tool into the chuck. When tightening turn the front part of the chuck (while holding the rear part) clockwise and ensure that the jaws of the chuck firmly and evenly clamp the working tool.

### **Torque control** (see pic. 4)

1. Torque control is ideal for presetting screwing strength. There are 19 positions + 1 drilling position. These positions are selected by turning the setting ring. Low values are intended for small screws and soft materials. High values are intended for large screws and hard materials.
2. If the torque control is used the clutch will work in the preset setting. This is ideal for repeat screwing, when all screws need to be screwed in at the same distance.
3. It is appropriate to start with the lowest setting and increase the amount of torque until the desired setting is achieved.

### **Turning on/off** (see pic. 5)

 **ATTENTION:** Start or release the start switch carefully according to the manufacturer's instructions.

Turn on the charged machine using the trigger switch (no. 1). The On indicator will appear on the LED display. Turn off the machine by releasing the switch, the chuck will stop turning.

1. Ensure that a battery is connected to the tool.
2. Start the tool by pressing the trigger switch.
3. The pressure applied to the power trigger switch determines the operating rotation speed of the chuck. The higher the pressure exerted on the trigger switch, the higher the rotation speed of the chuck.
4. If you want the chuck to rotate forwards, push the forward/back direction switch (no. 2) to the left. If you want the chuck to rotate backwards, push the forward/back direction switch to the right.
5. If the drill is not being used, set the forward/back direction switch (no. 2) to the neutral position (in the middle), to prevent accidentally starting the drill.

- Ensure that the bit or extension piece is correctly seated.
- The bit/extension piece must be placed directly on the workpiece before the drill is turned on. Otherwise the workpiece or the bit/extension piece will be damaged.
- Always check the rotation direction of the bit before using.
- The braking system is activated automatically after the trigger switch is released. The drill chuck will automatically stop rotating.

## 5. INSTRUCTIONS FOR PROPER USE

Fully charge the battery before first use. Ensure that the used drill bits and extension pieces are designed for the given task and that they are securely fastened. Check that the direction switch is set in the position for the desired rotation direction.

 **NOTE:** Always ensure that the battery is removed before changing working tools or before performing adjustments.

 **ATTENTION:** Dust created during grinding, cutting, drilling and other work tasks may in some cases contain chemical substances, which are known to cause health problems. Some examples of these chemical substances are:

- a) Lead from lead-containing paints.
- b) Cement and other construction products.
- c) Chemically treated wood.

### Screwing

1. An appropriate opening should be drilled into the workpiece before screws are screwed into wood. This will prevent the movement of the screw and tool on the surface of the workpiece, which could damage it.
2. We recommend that for screwing you use slow rotation speeds.
3. Insert the screwing bit into the head of the screw and carefully screw it into the opening.
4. We recommend tightening using the lowest torque value and to gradually increase the torque value until the desired torque level is achieved.

### Drilling

1. Do not use the torque control when drilling into wood. Select the standard drilling position.
2. When drilling into wood use wood drilling bits.
3. When drilling into metals or plastics use metal drilling bits.
4. When drilling into soft wood the drill should run at maximum speed.
5. When drilling into hard wood the drill should run at a lower speed.

### LED Battery charge level indicator light (see pic. 6)

The LED indicator light is used to show the battery charge level. When the tool is turned on by the trigger switch the LED light (no. 2) comes on. If all the LED diodes are on, the battery is sufficiently charged. If only a single LED diode is on, the battery is virtually flat and must be charged immediately.

### Lighting of the working area (see pic. 6)

The LED lighting (no. 1) is turned on when the trigger button is pressed and lights up the area that is being drilled or screwed. Turning off the trigger switch also turns off the LED lighting of the working area.

### More advice about drilling

1. We recommend to secure the workpiece to the workbench so that you achieve the best results and safely operate the tool.
2. Use only sharpened drill bits. Blunt drill bits put an unnecessary load on the drill and may cause the motor to burn.
3. Always ensure that you are using the correct working tool for the task being performed.
4. When performing high precision drilling it is best to use a drill bit with a guiding rod. Non-ferrous materials like thin metal sheets are very difficult to drill. When performing high precision drilling place a piece of wood underneath the drilled material and then drill an opening through both pieces of material.

**⚠ ATTENTION:** When drilling it is not unusual for the drill bit to jam. In such a case there is a large momentum reaction. Always pay attention to what you are doing and hold the drill firmly to prevent possible damage or injury.

**⚠ ATTENTION:** Do not hold the trigger button down in the on position using adhesive tape or by other means. The electrical circuit in the tool would not work correctly, which could lead to overheating and subsequent damage to the tool.

### Overload

If the tool becomes overloaded, the motor may be damaged. Increased pressure on the tool will not result in speeding up work. The effect of greater pressure on the tool will only lower effectiveness, which may cause the battery to go flat prematurely and may also destroy the motor. Non-standard types of work and the effect of excessive pressure will shorten the operating lifetime of the tool.

## 6. OPERATING INSTRUCTIONS

### Operation

- ✿ This product must not be used by children and persons with physical or mental impairments or by inexperienced persons, unless properly trained or schooled in the safe use of the product, or unless they have been properly supervised by a qualified person who will be responsible for their safety.
- ✿ Use extra care if the product is used near children. Always keep the appliance out of reach of children. Children must be supervised to ensure that they do not play with the product.
- ✿ Never allow children or persons who do not know the contents of this user's manual to work with the device. Local regulations may set the minimum age of the user. The user is responsible for damages caused to third parties in the machine's working area as a result of its use.
- ✿ Do not use the machine if you are tired, under the influence of alcohol or narcotics.
- ✿ If necessary, use personal protection aids (gloves, work footwear, eye protection, respirators, etc.). Personal protection aids reduce the risk of injury to persons.
- ✿ Dress appropriately. Do not wear loose clothing or jewellery and make sure that your hair, clothing or gloves do not come dangerously close to moving parts. Loose clothing, jewellery or long hair may become caught in the moving parts.

- ✿ Pay constant attention, watch what you are doing and think when working with power tools. Do not use power tools if you are tired or under the influence of drugs, alcohol or medication. A moment of carelessness when working with power tools may lead to serious injury.
- ✿ Prevent the situation where the tool is turned on accidentally. Ensure the trigger switch is in the Off position before connecting the power cord to the power socket. Carrying power tools with the finger on the main trigger switch or connecting the power cord to the power socket when the main trigger switch is in the On position may cause injury.
- ✿ Do not get in your own way. When working, always maintain a firm posture and balance. This will make it possible to better control the power tool in unexpected situations.
- ✿ Use clamps or a vice to fasten the workpiece. It is safer than holding the workpiece in your hand and at the same time you have both hands free to operate the tool.
- ✿ Keep the working area tidy and well illuminated. A cluttered and badly lit work area may lead to injury.
- ✿ Do not work with the power tool in an explosive environment, such as for example areas where there are flammable liquid, gas or powder substances. Sparks are made inside the power tool, which may cause the ignition of flammable powder or vapour.
- ✿ Do not work with materials containing asbestos. Use a dust mask.
- ✿ When working with the tool ensure there is a safe distance from children and other persons. Distractions may lead to a loss of control over the tool.

### **Purpose of use**

- ✿ This tool is not designed for professional use.
- ✿ Do not use the product for purposes other than those intended.
- ✿ For safety reasons the machine must not be used as a drive engine for any other work tools and tool sets, unless expressly permitted by the manufacturer.

### **Instructions for use**

- ✿ Turn on and operate the machine as described in the user's manual, carefully follow all instructions.
- ✿ Before carrying out any kind of inspection, maintenance or repairs disconnect the charger power cable from the mains power supply.
- ✿ Use tools in good working condition for tasks for which they are designed.
- ✿ Work only during good visibility or ensure sufficient artificial lighting.
- ✿ Work in a clean and tidy working environment.
- ✿ Make sure that while working you maintain a firm and stable stance. Do not forget that falls represent one of the major causes of injuries during accidents.
- ✿ When drilling metal sheets use a vice and place a piece of wood underneath the sheet. A rotating metal sheet presents a serious risk.
- ✿ Make sure that the drill or screwdriver are not used for work on items under live current, to prevent injury by electrical shock. Before using this tool, check that you know the location of all electrical conductors or cables in the wall (use a metal detector for this purpose).
- ✿ Only store and use the product away from flammable or volatile materials and solutions.
- ✿ Keep the product away from extreme temperatures, direct sunlight and excessive humidity. Do not use in a dusty environment.

- ✿ Do not place the product near heaters, open fires or other appliances or equipment that are sources of heat.
- ✿ Do not spray the product with water or any other liquid. Do not pour water or any other liquids into the appliance. Do not submerge the appliance in water or any other liquid.
- ✿ Never leave the appliance switched on without supervision.
- ✿ Do not touch machine parts until they have come to a complete stop.
- ✿ Allow the motor to cool down before storing the machine in a closed room.
- ✿ Under no circumstances should you repair or alter the product yourself. Entrust all repairs and adjustments of this product to an authorised service centre or the vendor. Tampering with the appliance during the warranty period may void the warranty.
- ✿ The manufacturer is not responsible for damages caused by incorrect use of this product or its accessories. Such damages include food spoilage, injuries, burns, scalding, fire, etc.

## Electrical safety

 **ATTENTION:** Read all the safety warnings and all instructions. If you fail to follow the provided warnings and instructions an injury caused by electrical shock could occur as well as fire or serious injuries.

 **NOTE:** Keep these warnings and instructions for future use. The term "electric power tool" in all warnings relates to your tool powered from the mains (it has a power cord installed) or cordless tools (without a power cord).

- ✿ The charger of the cordless device can be connected to any power plug, preventing discharge, that is installed according to norms in force.
- ✿ The plug must be powered at 230V ~50Hz.
- ✿ Disconnect the charger if you will not be using it for a long time, if you are changing the tool or performing maintenance on the tool.
- ✿ The power plug on the tool's charger cord must correspond to the power socket. Never modify the power plug in any way. Do not use any power plug adapters for tools protected by grounding. Unmodified power plugs and corresponding power sockets reduce the risk of injury by electrical shock.
- ✿ Do not touch grounded surfaces such as pipes, heaters, electrical stoves and refrigerators when working with the machine. When your body is grounded the risk of injury by electrical shock is increased.
- ✿ Do not expose the electrical tool to rain or a moist environment. The entry of water into the electrical tool increases the risk of injury by electrical shock.
- ✿ Handle the power cord with care. Never use the power cord to carry or move the tool and do not pull on it when you want to disconnect the tool from the power grid. Prevent the tool coming into contact with greasy, hot and sharp items or moving parts. A damaged or tangled up power cord increases the risk of injury by electrical shock.
- ✿ When working with electric power tools in a moist environment, the power circuit must have current protection installed (RSD - Residual Current Device). The use of a residual current device reduces the risk of injury by electrical shock.

## Safety instructions for the battery and charger

- ✿ Use only the battery and charger supplied with this tool.
- ✿ Connect the charger only to a mains power socket with a voltage of 230V.
- ✿ Protect the battery and charger from moisture. Do not use the device in an outdoor environment.
- ✿ Disconnect the charger from the mains power socket when the charger is not being used, before cleaning the charger or before performing repairs on it.
- ✿ Take special care of the battery. Prevent the battery from falling on to a hard surface and do not expose the battery to the effects of pressure or other excessive mechanical stress. Keep the battery at a safe distance from excessive heat or cold.
- ✿ Do not attempt to repair or disassemble the battery or the charger. If any part is damaged, have it repaired by a qualified technician or send it for repair to an authorised service centre or the vendor.
- ✿ Charge the battery only when the ambient air temperature is between 10°C and 40°C. A charged battery may be used to power tools in operating conditions at a temperature between 0°C and 50°C. If the battery is not being used store it in a dry place at a temperature between 10°C and 30°C.

**⚠ IMPORTANT! DANGER!** Never short circuit the battery contacts and do not expose the battery to moisture. Do not store the battery together with metal items and parts, which could cause a short circuit of the battery contacts. The battery could overheat, catch on fire or explode.

- ✿ If any person comes into contact with the electrolyte or another liquid or substance found in the battery, they must immediately wash this substance away with large amounts of water. If these substances come into contact with eyes, flush the eyes out with large amounts of water and immediately seek medical treatment.
- ✿ Do not throw rechargeable batteries into a fire or into water. Otherwise an explosion could occur. A rechargeable battery should not be thrown out with ordinary household waste, regardless of the fact whether it has or has not been used. In accordance with valid regulations you should take the battery to a collection point or put it into the container labelled "Used Batteries" in our store.
- ✿ Only charge the battery in a charger designated by the manufacturer. A charger appropriate for one type of battery creates a fire hazard when used with another type of battery.
- ✿ Only use the electric power tool with a battery intended to be used in it. The use of different batteries may lead to a risk of injury or a fire hazard.
- ✿ If you are not using the battery, store it away from metal items, such as paper clips, coins, keys, nails, screws or other small items, which could lead to the short circuit of the battery contacts. Short circuiting the battery contacts may cause burns or a fire.

# 7. MAINTENANCE AND STORAGE

## Maintenance

 **ATTENTION:** Disconnect the charger if you will not be using it for a long time, if you are changing the tool or performing maintenance on the tool.

- ✿ This tool does not require any special maintenance. The same applies to the electrical parts of the tool.
- ✿ Check whether the device is showing signs of wear.
- ✿ If the charger is damaged (cover, conductors or connector), immediately arrange its replacement at the vendors service centre.
- ✿ Regular care for the machine will ensure not only a long lifetime and performance.
- ✿ Before use always visually check for worn or damaged parts.
- ✿ Replace damaged or worn parts. To ensure that the machine always remains balanced, always replace the entire set of the worn or damaged tools.
- ✿ Worn or damaged machine parts may only be replaced at an authorised service centre or the vendor.
- ✿ Before cleaning disconnect this product from the power source.
- ✿ To clean the plastic parts of the product, use a soft cloth dipped in lukewarm water. Do not use aggressive cleaning products and solvents as this could damage the surface of the appliance.
- ✿ Do not clean the machine under running water or submerge under water.
- ✿ After changing the working tool, check that the working tool is secured in its storage position.
- ✿ Do not use working tools that are not proportioned for placement into the tang in the magazine.
- ✿ Do not overload the electric power tool. Use the right type of electric power tool for your work. When the correct electric power tool is used, the work result will be performed better and more safety.
- ✿ If it is not possible to turn the main trigger switch on or off, do not work with the tool. All electric power tools with a trigger switch that do not work are dangerous and must be repaired.
- ✿ If you are not working with the tool, store it out of the reach of children and prevent persons not informed about the operation of the tool or this user's manual to work with the tool. An electric power tool in the hands of an unqualified person is dangerous.
- ✿ Perform maintenance on the tool. Check for deviation or blockage of the moving parts, damage of individual parts and other factors which could affect the operation of the tool. If the tool is damaged, have it repaired before using it. Many accidents are caused by neglected maintenance of a tool. Properly maintained cutting tools with sharp cutting edges are less prone to jamming in a workpiece and are easier to handle.
- ✿ Maintain cutting tools sharp and clean. Properly maintained cutting tools with sharp cutting edges are less prone to jamming in a workpiece and are easier to handle.
- ✿ Use electric power tools, accessories, working tools, etc. according to these instructions in a manner appropriate for the given type of electric power tool and take into consideration the work conditions and the type of work that you will be performing. Using electric power tools for purposes other than those for which they were designed may be dangerous.
- ✿ Damaged switches must be replaced at an authorised service centre or the vendor. Do not use electric power tools that cannot be turn on and off.
- ✿ Do not leave electric power tools turned on without supervision. Always turn the tool off and wait for it to come to a complete stop before putting it down.

- ✿ Use hearing protection. Excessive noise levels may cause hearing damage.
- ✿ When performing tasks, where the working tools may come into contact with hidden electrical conductors, hold the electric power tool by the insulated part that is intended to be held. A work tool that comes into contact with a "live" electrical conductor, will cause the uninsulated parts of the tool to become live and may subsequently cause injury by electrical shock to the operator.
- ✿ For repairs contact an authorised service centre or vendor who will use original spare parts. This will ensure the correct operation of the electric power tool.

**⚠ ATTENTION:** Using any accessories or tools not recommended in this user's manual may increase the risk of injury. Always use only original spare parts.

- ✿ Clean the tool after the completion of every work task.
- ✿ Do not use worn or damaged drill bits and drilling extension pieces. Such tools may overload the motor and lower effectiveness.
- ✿ Take proper care to prevent the motor from damage by oil or water.
- ✿ Regularly check that the tool has not been damaged during the course of standard operation. Make sure that all parts are correctly connected and do not use this product if any of its parts has been damaged or lost.
- ✿ When inserting the battery into the charger, ensure that the battery is inserted in the correct manner and that there are no materials between the battery contacts, e.g. soils.
- ✿ The battery and the charger should be protected from heat and the sun. Do not expose these products to extreme temperatures.
- ✿ Do not use the device in an outdoor environment.
- ✿ Use only the charger supplied with this tool.
- ✿ If the product is damaged or malfunctions, contact an authorised service centre or the vendor.

## Storage

- ✿ Store the tool in a dry location at a sufficient distance from heat sources or dangerous vapours.
- ✿ Do not place any other items on the machine.



## 8. TECHNICAL SPECIFICATIONS

<b>Cordless Drill:</b>	
Nominal voltage	14.4V
Idling speed	0 - 400 / 0 - 1400rpm
Battery	1.3Ah, Li-ion
Torque	19 positions + 1 drilling position
Max. diameter	Ø13mm
Level of acoustic pressure	68.23dB, K = 3dB
Level of acoustic power	79.23dB, K = 3dB
<b>Charger:</b>	
Input voltage	230V
Frequency	50Hz
Charging time	1 - 1.5hours

Amendments to text and technical parameters are reserved.

Changes in the text, design and technical specifications may change without prior notice and we reserve the right to make these changes. keep it from turning as the drill bit rotates.

## 9. DISPOSAL

### **INSTRUCTIONS AND INFORMATION REGARDING THE DISPOSAL OF USED PACKAGING MATERIALS**

Dispose of packaging material at a public waste disposal site.

### **DISPOSAL OF USED ELECTRICAL AND ELECTRONIC APPLIANCES**



The meaning of the symbol on the product, its accessory or packaging indicates that this product shall not be treated as household waste. Please, dispose of this product at your applicable collection point for the recycling of electrical & electronic equipment waste. Alternatively in some states of the European Union or other European states you may return your products to your local retailer when buying an equivalent new product. The correct disposal of this product will help save valuable natural resources and help in preventing the potential negative impact on the environment and human health, which could be caused as a result of improper liquidation of waste. Please ask your local authorities or the nearest waste collection centre for further details. The improper disposal of this type of waste may fall subject to national regulations for fines.

### **CE For business entities in the European Union**

If you wish to dispose of an electrical or electronic device, request the necessary information from your seller or supplier.

### **Disposal in other countries outside the European Union**

If you wish to dispose of this product, request the necessary information about the correct disposal method from local government departments or from your seller.

This product meets all the basic EU regulation requirements that relate to it.

Changes to the text, design and technical specifications may occur without prior notice and we reserve the right to make these changes.

# 10. DECLARATION OF CONFORMITY

**Product / Name:** CORDLESS DRILL / FIELDMANN

**Type / Model:** FDV 1001-A / FDV 1002 - A ..... 14.4V DC / 1300mAh

## The product complies with the following directives:

- ✿ The Directive of the European Parliament and the Council No. 2006/95/EC dated 12 December 2006 on the harmonisation of the laws of Member States relating to electrical equipment designed for use within certain voltage limits.
- ✿ The Directive of the European Parliament and the Council No. 2004/108/EC dated 15 December 2004 on the harmonisation of the laws of the Member States relating to electromagnetic compatibility and repealing Directive No. 89/336/EEC.
- ✿ The Directive of the European Parliament and the Council No. 2006/42/EC dated 17 May 2006 on machinery, and amending Directive No. 95/16/EC.
- ✿ The Directive of the European Parliament and the Council No. 2002/95/EC dated 27 January 2003 on the restriction of the use of certain hazardous substances in electrical and electronic equipment.

## and standards:

- ✿ EN 60745-1:2006
- ✿ EN 60745-2-2:2007
- ✿ EN 60745-2-1:2007
- ✿ EN 55014 -1:2006
- ✿ EN 55014-2:1997/+A1:2001-1:2006
- ✿ EN 6000-6-3:2007-1:2006

**CE Certification** ..... 19

FAST ČR, a.s. is authorised to act on behalf of the manufacturer.

## Manufacturer:

FAST ČR, a.s.  
 Černokostelecká 2111, 100 00 Praha 10, Czech Republic  
 Tax ID:: CZ26726548

In Prague, 23 May 2013

**FAST** FAST ČR, a.s.  
 Černokostelecká 1621, 251 01 Píšťany  
 IČO: 26726548 tel.: +420/ 323 204 111  
 DIČ: CZ26726548 fax: +420/ 323 204 110

*Pul*

Name: Zdeněk Pech  
 Chairman of Board

Signature and Stamps



