

Appendix A

VHDL Primer

| | | |
|---------|---------------------------------------------------|------|
| A.1 | VHDL Standards History | A-1 |
| A.1.1 | IEEE Standard 1076 | A-1 |
| A.1.2 | IEEE Standard 1164 | A-1 |
| A.1.2.1 | IEEE Standard 1076.3 (Numeric Standard) | A-2 |
| A.1.2.2 | IEEE Standard 1076.4 (VITAL) | A-2 |
| A.2 | Learning VHDL | A-3 |
| A.2.1 | A Simple Example | A-3 |
| A.2.2 | Entity Declarations | A-4 |
| A.2.3 | Architecture Declarations | A-5 |
| A.2.4 | Data Types | A-6 |
| A.2.5 | Design Units | A-6 |
| A.2.6 | Levels of Abstraction | A-9 |
| A.2.6.1 | Sample Circuit | A-10 |
| A.2.6.2 | Comparator (Dataflow) | A-11 |
| A.2.6.3 | Barrel Shifter (Entity) | A-13 |
| A.2.6.4 | Signals and Variables | A-17 |
| A.2.6.5 | Using a Procedure | A-17 |
| A.2.6.6 | Structural VHDL | A-19 |
| A.2.6.7 | Design Hierarchy | A-20 |
| A.2.6.8 | Test Benches | A-21 |
| A.2.6.9 | Sample Test Bench | A-21 |
| A.3 | Conclusion | A-23 |
| A.4 | Examples Gallery | A-23 |
| A.4.1 | Using Type Version Functions | A-23 |
| A.4.1.1 | Design Description | A-24 |
| A.4.1.2 | Test Bench | A-26 |
| A.4.2 | Describing a State Machine | A-27 |
| A.4.2.1 | Design Description | A-27 |
| A.4.2.2 | Test Bench | A-30 |
| A.4.3 | Reading and Writing from Files | A-32 |

| | |
|-------------------------------------|------|
| A.4.3.1 Design Description. | A-33 |
| A.4.3.2 Test Bench. | A-34 |

Appendix A

VHDL Primer

This section provides a solid introduction to programming in VHDL. It is not intended to be a fully comprehensive VHDL reference. It is made up of an overview of VHDL standards, a section on learning VHDL, a conclusion and several examples.

A.1 VHDL Standards History

This section provides a detailed history of VHDL standards.

A.1.1 IEEE Standard 1076

In the early 1980s, a team of engineers from three companies — IBM, Texas Instruments and Intermetrics — were contracted by the Department of Defense to complete the specification and implementation of a new, language-based design description method. The first publicly available version of VHDL, version 7.2, was released in 1985. In 1986, the Institute of Electrical and Electronics Engineers, Inc. (IEEE) was presented with a proposal to standardize the language, which it did in 1987 after substantial enhancements and modifications were made by a team of commercial, government and academic representatives. The resulting standard, IEEE 1076-1987, is the basis for virtually every VHDL simulation and synthesis product sold today. An enhanced and updated version of the language, IEEE 1076-1993, was released in 1994, and VHDL tool vendors have been responding by adding these new language features to their products.

A.1.2 IEEE Standard 1164

Although IEEE Standard 1076 defines the complete VHDL language, there are aspects of the language that make it difficult to write completely portable design descriptions (descriptions that can be simulated identically using different vendors' tools). The problem stems from the

fact that VHDL supports many abstract data types, but it does not address the simple problem of characterizing different signal strengths or commonly used simulation conditions such as unknowns and high-impedance.

Soon after IEEE 1076-1987 was adopted, simulator companies began enhancing VHDL with new signal types (typically through the use of syntactically legal, but nonstandard, enumerated types) to allow their customers to accurately simulate complex electronic circuits. This caused problems because design descriptions entered using one simulator were often incompatible with other simulation environments. VHDL was quickly becoming nonstandard.

To get around the problem of nonstandard data types, another standard, numbered 1164, was created by an IEEE committee. It defines a standard package (a VHDL feature that allows commonly used declarations to be collected into an external library) containing definitions for a standard nine-valued data type. This standard data type is called `std_logic`, and the IEEE 1164 package is often referred to as the standard logic package, or MVL9 (for multi-valued logic, nine values).

The IEEE 1076-1987 and IEEE 1164 standards together form the VHDL standard in widest use today. (IEEE 1076-1993 is slowly working its way into the VHDL mainstream, but it does not add significant new features for synthesis users.)

A.1.2.1 IEEE Standard 1076.3 (Numeric Standard)

Standard 1076.3 (often called the Numeric Standard or Synthesis Standard) defines standard packages and interpretations for VHDL data types as they relate to actual hardware. This standard is intended to replace the many custom (nonstandard) packages that vendors of synthesis tools have created and distributed with their products.

IEEE Standard 1076.3 does for synthesis users what IEEE 1164 did for simulation users: increase the power of Standard 1076, while at the same time ensuring compatibility between different vendors' tools. The 1076.3 standard includes, among other things:

- A documented hardware interpretation of values belonging to the bit and boolean types defined by IEEE Standard 1076, as well as interpretations of the `std_ulogic` type defined by IEEE Standard 1164.
- A function that provides “don't care” or “wild card” testing of values based on the `std_ulogic` type. This is of particular use for synthesis, since it is often helpful to express logic in terms of “don't care” values.
- Definitions for standard signed and unsigned arithmetic data types, along with arithmetic, shift, and type conversion operations for those types.

A.1.2.2 IEEE Standard 1076.4 (VITAL)

The annotation of timing information to a simulation model is an important aspect of accurate digital simulation. The VHDL 1076 standard describes a variety of language features that can

be used for timing annotation; however, it does not describe a standard method for expressing timing data outside of the timing model itself.

The ability to separate the behavioral description of a simulation model from the timing specifications is important for many reasons. One of the major strengths of Verilog HDL is the fact that it includes a feature specifically intended for timing annotation. This feature, the Standard Delay Format (SDF), allows timing data to be expressed in a tabular form and included into the Verilog timing model at the time of simulation.

The IEEE 1076.4 standard, published by the IEEE in late 1995, adds this capability to VHDL as a standard package. A primary impetus behind this standard effort (which was dubbed VITAL, for VHDL Initiative Toward ASIC Libraries) was to make it easier for ASIC vendors and others to generate timing models applicable to both VHDL and Verilog HDL. For this reason, the underlying data formats of IEEE 1076.4 and Verilog's SDF are quite similar.

A.2 Learning VHDL

This section presents several sample circuits and shows how they can be described for synthesis and testing. These small examples are not intended to represent real applications, but will help you to understand the relationships between various types of VHDL statements and the actual hardware being described.

In addition to the quick introduction to VHDL presented in this section, very important concepts such as concurrency and hierarchy will be introduced. Before explaining these more complex topics, a very simple example will be presented so you can see what constitutes the minimum VHDL source file.

A.2.1 A Simple Example

The following is a look at a very simple combinational circuit: an 8-bit comparator. This comparator will accept two 8-bit inputs, compare them, and produce a 1-bit result (either 1, indicating a match, or 0, indicating a difference between the two input values). A comparator such as this is a combinational function constructed in circuitry from an arrangement of exclusive-OR gates or from some other lower-level structure depending on the capabilities of the target technology. (It is the job of logic synthesis to determine exactly what hardware representation is most appropriate for a given device.)

```
entity compare is
    port(A,B: in bit;
         EQ: out bit);
end compare;

architecture compare1 of compare is
```

```
begin
    EQ <= '1' when (A = B) else '0';
end compare1;
```

Reading from the top of the source file, you can see the following elements:

- An entity declaration that defines the inputs and outputs — the ports — of this circuit.
- An architecture declaration that defines what the circuit actually does, using a single concurrent assignment.

Every VHDL design description consists of the following:

1. At least one entity/architecture pair, which in VHDL jargon is sometimes referred to as a “design entity”. In a large design, you will typically write many entity/architecture pairs and connect them together to form a complete circuit.

An entity declaration describes the circuit as it appears from the “outside”, that is, from the perspective of its input and output interfaces. If you are familiar with schematics, you might think of the entity declaration as being analogous to a block symbol on a schematic.

2. The architecture declaration, which refers to the fact that every entity in a VHDL design description must be bound with a corresponding architecture. The architecture describes the actual function — or contents — of the entity to which it is bound.

A.2.2 Entity Declarations

An entity declaration provides the complete interface for a circuit. Using the information provided in an entity declaration (the names, data types and direction of each port), you have all the information you need to connect that portion of a circuit into other, higher-level circuits, or to develop input stimulus (in the form of a test bench) for testing purposes. The actual operation of the circuit, however, is not included in the entity declaration.

The following entity declaration contains a simple design description:

```
entity compare is
    port( A, B: in bit_vector(0 to 7);
          EQ: out bit);
end compare;
```

The entity declaration includes a name, compare, and port declaration statement defining all the inputs and outputs of the entity. The port list includes definitions of three ports: A, B, and EQ. Each of these three ports is given a direction (in, out or inout), and a type (in this case,

either `bit_vector(0 to 7)`, which specifies an 8-bit array, or `bit`, which represents a single-bit value).

There are many different data types available in VHDL. To keep this introductory circuit simple, the simplest data types in VHDL, `bit` and `bit_vector`, will be used.

A.2.3 Architecture Declarations

Every entity declaration you write must be accompanied by at least one corresponding architecture.

The architecture declaration for the comparator circuit is as follows:

```
architecture compare1 of compare is
begin
    EQ <= '1' when (A = B) else '0';
end compare1;
```

The architecture declaration begins with a unique name, “compare1”, followed by the name of the entity to which the architecture is bound, in this case “compare”. Within the architecture declaration (between the `begin` and `end` keywords) is found the actual functional description of our comparator. There are many ways to describe combinational logic functions in VHDL; the method used in this simple design description is a type of concurrent statement known as a conditional assignment. This assignment specifies that the value of the output (EQ) will be assigned a value of ‘1’ when A and B are equal, and a value of ‘0’ when they differ.

This single concurrent assignment demonstrates the simplest form of a VHDL architecture. There are many different types of concurrent statements available in VHDL, allowing you to describe very complex architectures. Hierarchy and subprogram features of the language allow you to include lower-level components, subroutines and functions in your architectures, and a powerful statement known as a “process” allows you to describe complex sequential logic as well.

A.2.4 Data Types

Like a high-level software programming language, VHDL allows data to be represented in terms of high-level data types. These data types can represent individual wires in a circuit, or they can represent collections of wires using a concept called an “array”.

The preceding description of the comparator circuit used the data types `bit` and `bit_vector` for its inputs and outputs. The `bit` data type has only two possible values: ‘1’ or ‘0’. (A `bit_vector` is simply an array of bits.) Every data type in VHDL has a defined set of values, and a defined set of valid operations. Type checking is strict, so it is not possible, for example, to directly assign the value of an integer data type to a `bit_vector` data type. (There are ways to get around this restriction, using what are called type conversion functions. These are not discussed in this manual, but examples of their use are provided in “A.4 Examples Gallery” on page A-23.

The following chart summarizes the fundamental data types available in VHDL.

| Data Type | Values | Example |
|------------|-----------------------------|-------------------------------------------|
| Bit | ‘1’, ‘0’ | <code>Q <= ‘1’;</code> |
| Bit_vector | (array of bits) | <code>DataOut <= “00010101”;</code> |
| Boolean | True, False | <code>EQ <= True;</code> |
| Integer | -2, -1, 0, 1, 2, 3, 4, etc. | <code>Count <= Count + 2;</code> |
| Real | 1.0, -1.0E5, etc. | <code>V1 = V2 / 5.3</code> |
| Physical | 1 ua, 7 ns, 100 ps, etc. | <code>Q <= ‘1’ after 6 ns;</code> |
| Record | (various) | <code>Tvec := (Clk, Inp, Result);</code> |
| Character | ‘a’, ‘b’, ‘2’, ‘\$’, etc. | <code>CharData <= ‘X’;</code> |
| String | (Array of characters) | <code>Msg <= “MEM: “ & Addr</code> |

A.2.5 Design Units

One concept unique to VHDL (when compared to software programming languages and to Verilog HDL) is the concept of a “design unit”. Design units (which may also be referred to as “library units”) are segments of VHDL code that can be compiled separately and stored in a library. You have been introduced to two design units already: the entity and the architecture. There are actually five types of design units in VHDL: entities, architectures, packages, package bodies, and configurations.

1. The diagram below illustrates the relationship of these five design units:

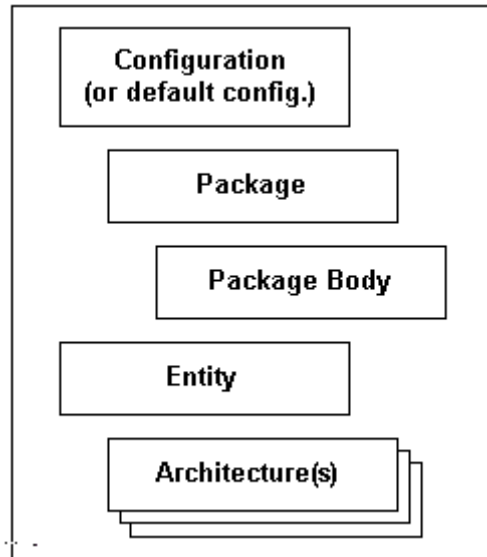

- Entities

A VHDL entity is a statement (identified by the `entity` keyword) that defines the external specification of a circuit or sub-circuit. The minimum VHDL design description must include at least one entity and one corresponding architecture.

When you write an entity declaration, you must provide a unique name for that entity and a port list defining the input and output ports of the circuit. Each port in the port list must be given a name, direction (or “mode”, in VHDL jargon) and a type. Optionally, you may also include a special type of parameter list (called a generic list) that allows you to pass additional information into an entity.

- Architectures

A VHDL architecture declaration is a statement (beginning with the `architecture` keyword) that describes the underlying function and/or structure of a circuit. Each architecture in your design must be associated (or bound) by name with one entity in the design.

VHDL allows you to create more than one alternate architecture for each entity. This feature is particularly useful for simulation and for project team environments in which the design of the system interfaces (expressed as entities) is done by a different engineer than the lower-level architectural description of each component circuit.

An architecture declaration consists of zero or more declarations (of items such as intermediate signals, components that will be referenced in the architecture, local functions

and procedures, and constants) followed by a `begin` statement, a series of concurrent statements, and an `end` statement.

- Packages and Package Bodies

A VHDL package declaration is identified by the `package` keyword, and is used to collect commonly-used declarations for use globally among different design units. You can think of a package as a common storage area, one used to store such things as type declarations, constants, and global subprograms. Items defined within a package can be made visible to any other design unit in the complete VHDL design, and they can be compiled into libraries for later re-use.

A package can consist of two basic parts: a package declaration and an optional package body. Package declarations can contain the following types of statements:

- type and subtype declarations
- constant declarations
- global signal declarations
- function and procedure declarations
- attribute specifications
- file declarations
- component declarations
- alias declarations
- disconnect specifications
- use clauses.

Items appearing within a package declaration can be made visible to other design units through the use of a `use` statement, as will be shown.

If the package contains declarations of subprograms (functions or procedures) or defines one or more deferred constants (constants whose value is not immediately given), then a package body is required in addition to the package declaration. A package body (which is specified using the `package body` keyword combination) must have the same name as its corresponding package declaration, but it can be located anywhere in the design (it does not have to be located immediately after the package declaration).

The relationship between a package and package body is somewhat akin to the relationship between an entity and its corresponding architecture. (There may be only one package body written for each package declaration, however.) While the package declaration provides the information needed to use the items defined within it (the parameter list for a global procedure, or the name of a defined type or subtype), the actual behavior of such elements as procedures and functions must be specified within package bodies.

Examples of global procedures and functions can be found in “A.4 Examples Gallery” on page A-23.

- Configurations

The final type of design unit available in VHDL is called a configuration declaration. A configuration declaration (identified with the `configuration` keyword) specifies which architectures are to be bound to which entities, and allows you to change how components are connected in your design description at the time of simulation or synthesis.

Configuration declarations are always optional, no matter how complex a design description you create. In the absence of a configuration declaration, the VHDL standard specifies a set of rules that provide you with a default configuration. For example, in the case where you have provided more than one architecture for an entity, the last architecture compiled will take precedence and will be bound to the entity.

A.2.6 Levels of Abstraction

VHDL supports many possible styles of design description. These styles differ primarily in how closely they relate to the underlying hardware. The different styles of VHDL refer to the differing levels of abstraction possible using the language — behavior, dataflow, and structure — as shown in the following diagram:

This figure maps the various points in a top-down design process to the three general levels of abstraction. Starting at the top, suppose the performance specifications for a given project are: “the compressed data coming out of the DSP chip needs to be analyzed and stored within 70 nanoseconds of the Strobe signal being asserted...” This human language specification must be refined into a description that can actually be simulated. A test bench written in combination with a sequential description is one such expression of the design. These are all points in the behavior level of abstraction.

After this initial simulation, the design must be further refined until the description is something a VHDL synthesis tool can digest. That is the dataflow level of abstraction.

The structure level of abstraction occurs when smaller segments of circuitry are being connected together to form a larger circuit. The structure level is commonly thought of as a circuit netlist, or perhaps a higher-level block diagram.

The three levels of abstraction are as follows:

1. Behavior

The highest level of abstraction supported in VHDL is called the behavior level of abstraction. When creating a behavioral description of a circuit, you will describe your circuit in terms of its operation over time. The concept of time is the critical distinction between behavioral descriptions of circuits and lower-level descriptions (specifically descriptions created at the dataflow level of abstraction).

In a behavioral description, the concept of time may be expressed precisely, with actual delays between related events (such as the propagation delays within gates and on wires),

or it may simply be an ordering of operations that are expressed sequentially (such as in a functional description of a flip-flop). When you are writing VHDL for input to synthesis tools, you may use behavioral statements to imply that there are registers in your circuit. It is unlikely, however, that your synthesis tool will be capable of creating precisely the same behavior in actual circuitry as you have defined in the language. (Synthesis tools today ignore detailed timing specifications, leaving the actual timing results to the target device technology.)

If you are familiar with event-driven software programming, writing behavior-level VHDL will not seem like anything new. Just like with a programming language, you will be writing one or more small programs that operate sequentially and communicate with one another through their interfaces. The only difference between behavior-level VHDL and a software programming language is the underlying execution platform: in the case of software, it is some operating system running on a CPU; in the case of VHDL, it is the simulator.

2. Dataflow

In the dataflow level of abstraction, you describe your circuit in terms of how data moves through the system. At the heart of most digital systems today are registers, so in the dataflow level of abstraction you describe how information is passed between registers in the circuit. You will probably describe the combinational logic portion of your circuit at a relatively high level (and let a synthesis tool figure out the detailed implementation in logic gates), but you will likely be quite specific about the placement and operation of registers in the complete circuit.

3. Structure

The third level of abstraction, structure, is used to describe a circuit in terms of its components. Structure can be used to create a very low-level description of a circuit (such as a transistor-level description) or a very high-level description (such as a block diagram).

In a gate-level description of a circuit, for example, components such as basic logic gates and flip-flops might be connected in some logical structure to create the circuit. This is what is often called a netlist. For a higher-level circuit (one in which the components being connected are larger functional blocks), structure might simply be used to segment the design description into manageable parts.

Structure-level VHDL features such as components and configurations are very useful for managing complexity. The use of components can dramatically improve your ability to reuse elements of your designs, and they can make it possible to work using a top-down design approach.

A.2.6.1 Sample Circuit

To help demonstrate some of the important concepts covered so far in this section, a very simple circuit will be presented. It will show how the function of this circuit can be described in

VHDL. The design descriptions shown are intended for synthesis and therefore do not include timing specifications or other information not directly applicable to today's synthesis tools.

The circuit combines the comparator circuit presented in "A.2.1 A Simple Example" on page A-3 with a simple 8-bit loadable shift register. The shift register will allow a detailed examination of how behavior-level VHDL can be written for synthesis.

The two subcircuits (the shifter and comparator) will be connected using VHDL's hierarchy features and will demonstrate the third level of abstraction: structure. The complete circuit is shown below:

This diagram has been intentionally drawn to look like a hierarchical schematic with each of the lower-level circuits represented as blocks. In fact, many of the concepts to be covered during the development of this circuit are familiar to users of schematic hierarchy. These concepts include the ideas of component instantiation, mapping of ports, and design partitioning.

In a more structured project environment, you would probably enter a circuit such as this by first defining the interface requirements of each block, then describing the overall design of the circuit as a collection of blocks connected together through hierarchy at the top level. Later, after the system interfaces had been designed, you would proceed down the hierarchy (using a top-down approach to design) and fill in the details of each subcircuit.

In this example, however, each of the lower-level blocks will be described and then they will be connected to form the complete circuit.

A.2.6.2 Comparator (Dataflow)

The comparator portion of the design will be identical to the simple 8-bit comparator already shown. The only difference is that the IEEE 1164 standard logic data types (`std_ulogic` and `std_ulogic_vector`) will be used rather than the `bit` and `bit_vector` data types used previously. Using standard logic data types for all system interfaces is highly recommended, as it allows circuit elements from different sources to be easily combined. It also provides you the opportunity to perform more detailed and precise simulation than would otherwise be possible.

The updated comparator design, using the IEEE 1164 standard logic data types, is shown below:

```
-----
-- Eight-bit comparator

library ieee;
use ieee.std_logic_1164.all;
entity compare is
    port (A, B: in std_ulogic_vector(0 to 7);
          EQ: out std_ulogic);
```

```
end compare;  
  
architecture compare1 of compare is  
begin  
    EQ <= '1' when (A = B) else '0';  
end compare1;
```

Reading from the top of the source file, you can see the following:

- a comment field, indicated by the leading double-dash symbol (“--”). VHDL allows comments to be embedded anywhere in your source file, provided they are prefaced by the two hyphen characters as shown. Comments in VHDL extend from the double hyphen symbol to the end of the current line. (There is no block comment facility in VHDL.)
- a `library` statement that causes the named library IEEE to be loaded into the current compile session. When you use VHDL libraries, it is recommended that you include your library statements once at the beginning of the source file, before any `use` clauses or other VHDL statements.
- a `use` clause, specifying which items from the IEEE library are to be made visible for the subsequent design unit (the entity and its corresponding architecture). The general form of a `use` statement includes three fields delimited by a period: the library name (in this case “ieee”), a design unit within the library (normally a package, in this case named “std_logic_1164”), and the specific item within that design unit (or, as in this case, the special keyword `all`, which means “everything”) to be made visible.
- an entity declaration describing the interface to the comparator. Note that `std_ulogic` and `std_ulogic_vector`, which are standard data types provided in the IEEE 1164 standard and in the associated IEEE library, were specified.
- an architecture declaration describing the actual function of the comparator circuit.

Conditional Signal Assignment

The function of the comparator is defined using a simple concurrent assignment to port EQ. The type of statement used in the assignment to EQ is called a “conditional signal assignment”. Conditional signal assignments make use of the “when-else” language feature and allow complex conditional logic to be described. The following description of a multiplexer circuit makes the use of the conditional signal assignment more clear:

```
architecture mux1 of mux is  
begin  
  
    Y <=      A when (Sel = "00") else  
             B when (Sel = "01") else  
             C when (Sel = "10") else  
             D when (Sel = "11");
```

```
end mux1;
```

Selected Signal Assignment

This form of signal assignment can be used as an alternative to the conditional signal assignment. The selected signal assignment has the following general form (again, using a multiplexer as an example):

```
architecture mux2 of mux is
begin

    with Sel select
        Y <=      A when "00",
                  B when "01",
                  C when "10",
                  D when "11";

end mux2;
```

Choosing between a conditional or selected signal assignment for circuits such as this is largely a matter of taste. For most designs, there is no difference in the results obtained with either type of assignment statement.

A.2.6.3 Barrel Shifter (Entity)

The second and most complex part of this design is the barrel shifter circuit. This circuit (diagrammed below) accepts 8-bit input data, loads this data into a register and, when the load input signal is low, rotates this data by one bit with each rising edge clock signal. The circuit is provided with an asynchronous reset, and the data stored in the register is accessible via the output signal Q.

They are many ways to describe a circuit such as this in VHDL. If you are going to use synthesis tools to process the design description into an actual device technology, however, you must restrict yourself to well established synthesis conventions when entering the circuit. Two of these conventions will be looked at below.

Using a Process

The first design description to be looked at for this shifter is a description that uses a VHDL process statement to describe the behavior of the entire circuit over time. This is the behavioral level of abstraction. It represents the highest level of abstraction practical (and synthesizable) for registered circuits such as this one. The VHDL source code for the barrel shifter is shown below:

```

-- Eight-bit barrel shifter

library ieee;
use ieee.std_logic_1164.all;
entity rotate is
    port( Clk, Rst, Load: in std_ulogic;
          Data: in std_ulogic_vector(0 to 7);
          Q: out std_ulogic_vector(0 to 7));
end rotate;

architecture rotat1 of rotate is
begin
    reg: process(Rst,Clk)
        variable Qreg: std_ulogic_vector(0 to 7);
    begin
        if Rst = '1' then -- Async reset
            Qreg := "00000000";
        elsif (Clk = '1' and Clk'event) then
            if (Load = '1') then
                Qreg := Data;
            else
                Qreg := Qreg(1 to 7) & Qreg(0);
            end if;
        end if;
        Q <= Qreg;
    end process;
end rotat1;

```

Reading from the top of the source file, you can see the following:

- a comment field, as described previously.
- library and use statements, allowing us to use the IEEE 1164 standard logic data types.
- an entity declaration defining the interface to the circuit. Note that the direction (mode) of Q is written as `out`, indicating that it will not be used directly as the lower-level storage object (Q will not be fed back directly).
- an architecture declaration, consisting of a single process statement that defines the operation of the shifter over time in response to events appearing on the clock (Clk) and asynchronous reset (Rst).

Process Statement

The process statement in VHDL is the primary means by which sequential operations (such as registered circuits) can be described. When describing registered circuits, the most common form of a process statement is:

```
architecture arch_name of ent_name is
begin
    process_name: process(sensitivity_list)
        local_declaration;
        local_declaration;
        . . .
    begin
        sequential_statement;
        sequential_statement;
        sequential_statement;
        .
        .
        .
    end process;
end arch_name;
```

A process statement consists of the following items:

- An optional process name (an identifier followed by a colon).
- The `process` keyword.
- An optional sensitivity list, indicating which signals result in the process “executing” when there is some event detected. (The sensitivity list is required if the process does not include one or more `wait` statements to suspend its execution at certain points. An example that does not use a sensitivity list is discussed in “A.2.6.5 Using a Procedure” on page A-17.
- An optional declarations section, allowing local objects and subprograms to be defined.
- A `begin` keyword.
- A sequence of statements to be executed when the program runs.
- An `end` statement.

The easiest way to think of a VHDL process such as this is to relate it to software, as a program that executes (in simulation) any time there is an event on one of its inputs (as specified in the sensitivity list). A process describes the sequential execution of statements that are dependent on one or more events occurring. A flip-flop is a perfect example of such a situation; it remains idle, not changing state, until there is a significant event (either a rising edge on the clock input or an asynchronous reset event) that causes it to operate and potentially change its state.

Although there is a definite order of operations within a process (from top to bottom), you can think of a process as executing in zero time. This means that (a) a process can be used to describe circuits functionally, without regard to their actual timing, and (b) multiple processes can be “executed” in parallel with little or no concern for which processes complete their

operations first. (There are certain caveats to this behavior of VHDL processes. These caveats are described in detail in most VHDL textbooks.)

For your reference, the process of how the barrel shifter operates is shown below:

```
reg: process(Rst,Clk)
    variable Qreg: std_ulogic_vector(0 to 7);
begin
    if Rst = '1' then -- Async reset
        Qreg := "00000000";
    elsif (Clk = '1' and Clk'event) then
        if (Load = '1') then
            Qreg := Data;
        else
            Qreg := Qreg(1 to 7) & Qreg(0);
        end if;
    end if;
    Q <= Qreg;
end process;
```

As written, the process is dependent on (or sensitive to) the asynchronous inputs Rst and Clk. These are the only signals that can have events directly affecting the operation of the circuit; in the absence of any event on either of these signals, the circuit described by the process will simply hold its current value (that is, the process will remain suspended).

Consider what happens when an event occurs on either one of these asynchronous inputs. First, look at what happens when the input Rst has an event in which it transitions to a high state (represented by the `std_ulogic` value of '1'). In this case, the process will begin execution and the first `if` statement will be evaluated. Because the event was a transition to '1', the simulator will see that the specified condition (`Rst = '1'`) is true and the assignment of variable Qreg to the reset value of "00000000" will be performed. The remaining statements of the `if-then-elsif` expression (those that are dependent on the `elsif` condition) will be ignored. The final statement in the process, the assignment of output signal Q to the value of Qreg, is not subject to the `if-then-elsif` expression and is therefore placed on the process queue for execution. (Signal assignments do not occur until the process actually suspends.) Finally, the process suspends, all signals that were assigned values in the process (in this case Q) are updated, and the process waits for another event on Clk or Rst.

What about the case in which there is an event on Clk? In this case, the process will again execute, and the `if-then-elsif` expressions will be evaluated in turn until a valid condition is encountered. If the Rst input continues to have a high value (a value of '1'), then the simulator will evaluate the first `if` test as true, and the reset condition will take priority. If, however, the Rst input is not a value of '1', then the next expression (`Clk = '1' and Clk'event`) will be evaluated. This expression is the most commonly-used convention for detecting clock edges

in VHDL. To detect a rising edge clock, write the expression `Clk = '1'` in the conditional expression. For this circuit, however, the expression `Clk = '1'` would not be specific enough, since the process may have begun execution as the result of an event on `Rst` that did not result in `Rst` transitioning to a '1'. (For example, a falling edge event on `Rst` — that is, a transition from 1 to 0 — would trigger the process but cause it to skip to the `elsif` statement even though there was no event on `Clk`, since the `Rst = 1` condition would evaluate as false.) To ensure that the event we are responding to is in fact an event on `Clk`, we use the built-in VHDL attribute 'event' to check if `Clk` was the signal triggering the process execution.

If the event that triggered the process execution was in fact a rising edge on `Clk`, then the simulator will go on to check the remaining if-then logic to determine which assignment statement is to be executed. If `Load` is determined to be '1', then the first assignment statement is executed and the data is loaded from input data to the registers. If `Load` is not '1', then the data in the registers is shifted, as specified using the bit slice and concatenation operations available in the language.

Note Every assignment to a variable or signal you make that is dependent on a `Clk = '1'` and `Clk'event` expression will result in at least one register when synthesized.

A.2.6.4 Signals and Variables

There are two fundamental types of objects used to carry data from place to place in a VHDL design description: signals and variables. In virtually all cases, you will want to use variables to carry data between sequential operations (within processes, procedures and functions) and use signals to carry information between concurrent elements of your design (such as between two independent processes).

Examples of signals and variables, and differences between them, are shown in more detail in “A.4 Examples Gallery” on page A-23. For now, it is useful to think of signals as wires (as in a schematic) and variables as temporary storage areas (similar to variables in a traditional software programming language).

In many cases, you can choose whether to use signals or variables to perform the same task. As a general rule, you should use variables whenever possible and use signals only when you must access data across different concurrent parts of your design.

A.2.6.5 Using a Procedure

Describing registered logic using processes requires that you follow some established conventions (if you intend to synthesize the design) and to consider the behavior of the entire circuit. In the barrel shifter design description shown in “Process Statement” on page A-14, the registers were implied by the placement and use of statements such as `if Clk = '1'` and `Clk'event`. Assignment statements subject to that clause resulted in D-type flip-flops being implied for the signals.

VHDL Primer

For smaller circuits, this mixing of combinational logic functions and registers is fine and not difficult to understand. For larger circuits, however, the complexity of the system being described can make such descriptions hard to manage, and the results of synthesis can often be confusing. For these circuits, it often makes more sense to retreat to a dataflow level of abstraction and to clearly define the boundaries between registered and combinational logic.

One easy way to do this is to remove the process from your design and replace it with a series of concurrent statements representing the combinational and registered portions of the circuit. The following VHDL design description uses this method to describe the same barrel shifter circuit previously described:

```
architecture rotate3 of rotate is
    signal D,Qreg: std_logic_vector(0 to 7);
begin

    D <= Data when (Load = '1') else
        Qreg(1 to 7) & Qreg(0);

    dff(Rst, Clk, D, Qreg);

    Q <= Qreg;

end rotate3;
```

In this version of the design description, the behavior of the D-type flip-flop has been placed in an external procedure, `dff`, and intermediate signals have been introduced to more clearly describe the separation between the combinational and registered parts of the circuit. The following diagram helps illustrate this separation:

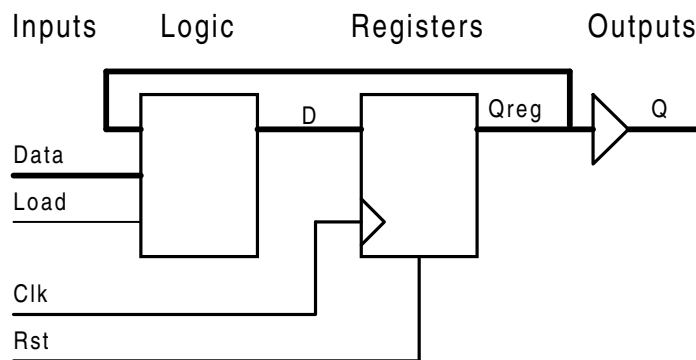

In this example, the combinational logic of the counter has been written in the form of a single concurrent signal assignment, while the registered operation of the counter's output has been described using a call to a procedure named `dff`.

What does the `dff` procedure look like? The following is one possible procedure for a D-type flip-flop:

```
procedure dff (signal Rst, Clk: in std_ulogic;
              signal D: in std_ulogic_vector(0 to 7);
              signal Q: out std_ulogic_vector(0 to 7)) is
begin
    if Rst = '1' then
        Q <= "00000000";
    elsif Clk = '1' and Clk'event then
        Q <= D;
    end if;
end dff;
```

Notice that this procedure has a striking resemblance to the process statement presented earlier. The same if-then-elsif structure used in the process is used to describe the behavior of the registers. Instead of a sensitivity list, however, the procedure has a parameter list describing the inputs and outputs of the procedure.

The parameters defined within a procedure or function definition are called its formal parameters. When the procedure or function is executed in simulation, the formal parameters are replaced by the values of the actual parameters specified when the procedure or function is used. If the actual parameters being passed into the procedure or function are signal objects, then the signal keyword can be used (as shown above) to ensure that all information about the signal object, including its value and all of its attributes, is passed into the procedure or function.

A.2.6.6 Structural VHDL

The structure level of abstraction is used to combine multiple components to form a larger circuit or system. As such, structure can be used to help manage a large and complex design, and structure can make it possible to reuse components of a system in other design projects.

Because structure only defines the interconnections between components, it cannot be used to completely describe the function of a circuit; at some level, all aspects of your circuit must be described using behavioral and/or dataflow levels of abstraction.

To demonstrate how the structure level of abstraction can be used to connect lower-level circuit elements into a larger circuit, the comparator and shift register circuits will be connected into a larger circuit as shown below.

Note This diagram was drawn in much the same way you might enter it into Multisim. Structural VHDL has many similarities with schematic-based design.

A.2.6.7 Design Hierarchy

When you write structural VHDL, you are in essence writing a textual description of a schematic netlist (a description of how the components on the schematic are connected by wires, or nets). In the world of schematic entry tools, such netlists are usually created for you automatically by the schematic editor, as Multisim does. When writing VHDL, you enter the same sort of information by hand.

When you use components and wires (signals, in VHDL) to connect multiple circuit elements together, it is useful to think of your new, larger circuit in terms of a hierarchy of components. In this view, the top-level drawing (or top-level VHDL entity and architecture) can be seen as the highest level in a hierarchy tree, as shown below.

```
library ieee;
use ieee.std_logic_1164.all;
entity rotcomp is port(Clk, Rst, Load: in std_ulogic;
                      Init: in
std_ulogic_vector(0 to 7);
                      Test: in
std_ulogic_vector(0 to 7);
                      Limit: out std_ulogic);
end rotcomp;

architecture structure of rotcomp is

    component compare
        port(A, B: in std_ulogic_vector(0 to 7); EQ: out
std_ulogic);
    end component;

    component rotate
        port(Clk, Rst, Load: in std_ulogic;
              Data: in std_ulogic_vector(0 to 7);
              Q: out std_ulogic_vector(0 to 7));
    end component;

    signal Q: std_ulogic_vector(0 to 7);

begin

    COMP1: compare port map (A=>Q, B=>Test, EQ=>Limit);
```

```
    ROT1: rotate port map (Clk=>Clk, Rst=>Rst, Load=>Load,  
Data=>Init, Q=>Q);  
  
end structure;
```

A.2.6.8 Test Benches

At this point, the sample circuit is complete and ready to be processed by synthesis tools. Before processing the design, however, you should take the time to verify that it actually does what it is intended to do. You should run a simulation.

Simulating a circuit such as this one requires that you provide more than just the design description itself. To verify the proper operation of the circuit over time in response to input stimulus, you will need to write a test bench.

The easiest way to understand the concept of a test bench is to think of it as a virtual tester circuit. This tester circuit, which you will describe in VHDL, applies stimulus to your design description and (optionally) verifies that the simulated circuit does what it is intended to do.

The diagram below graphically illustrates the relationship between the test bench and your design description, which is called the unit under test, or UUT.

To apply stimulus to your design, your test bench will probably be written using one or more sequential processes, and it will use a series of signal assignments and wait statements to describe the actual stimulus. You will probably use VHDL's looping features to simplify the description of repetitive stimulus (such as the system clock), and you may also use VHDL's file and record features to apply stimulus in the form of test vectors.

To check the results of simulation, you will probably make use of VHDL's assert feature, and you may also use the file features to write the simulation results to a disk file for later analysis.

For complex design descriptions, developing a comprehensive test bench can be a large-scale project in itself. In fact, it is not unusual for the test bench to be larger and more complex than the design description. For this reason, you should plan your project so that you have the time required to develop the function test in addition to developing the circuit being tested. You should also plan to create test benches that are re-usable, perhaps by developing a master test bench that reads test data from a file.

When you create a test bench for your design, you use the structural level of abstraction to connect your lower-level (previously top-level) design description to the other parts of the test bench.

A.2.6.9 Sample Test Bench

The following VHDL source statements describe a simple test bench for the shift and compare circuit. This test bench uses two processes that operate concurrently. One process (clock)

describes a background clock with a 100 ns period, while the second process (stimulus) describes a sequence of inputs to be applied to the circuit over time.

Note This sample test bench does not include any checking of output values. More complex test benches that include output value checking are presented in “A.4 Examples Gallery” on page A-23.

```

library ieee;
use ieee.std_logic_1164.all;

entity testbnch is-- No ports needed in a
end testbnch;-- testbench

architecture behavior of testbnch is
    component rotcomp is-- Declares the lower-level
        port(Clk, Rst, Load: in std_ulogic;-- component
            and its ports
                Init: in std_ulogic_vector(0 to 7);
                Test: in std_ulogic_vector(0 to 7);
                Limit: out std_ulogic);
    end component;
    signal Clk, Rst, Load: std_ulogic;-- Introduces top-level signals
    signal Init: std_ulogic_vector(0 to 7);-- to use when
    signal Test: std_ulogic_vector(0 to 7);-- testing the lower-level
circuit
    signal Limit: std_ulogic;
begin
    DUT: rotcomp port map-- Creates an instance of the
        (Clk, Rst, Load, Init, Test, Limit);-- lower-level circuit (the
-- design under test)
    clock: process
        variable clktmp: std_ulogic := '0';-- This process sets up a
begin-- background clock of 100 ns
        clktmp := not clktmp;-- period.
        Clk <= clktmp;
        wait for 50 ns;
    end process;

    stimulus: process-- This process applies
begin-- stimulus to the design
        Rst <= '0';-- inputs, then waits for some
        Load <= '1';-- amount of time so we can
        Init <= "00001111";-- observe the results during
        Test <= "11110000";-- simulation.

```



```
        wait for 100 ns;  
        Load <= '0';  
        wait for 600 ns;  
    end process;  
  
end behavior;
```

A.3 Conclusion

In this section the most important concepts and features of VHDL were explored. We hope this introduction was a useful refresher for experienced VHDL users, and a good introduction to the language for the novice. VHDL is a rich and powerful language, however, and there is much more to learn before you become a “master user”. To continue your learning, it is strongly recommended that you acquire at least one textbook on VHDL, and also obtain a copy of the IEEE 1076 VHDL Language Reference Manual. There are also many good quality VHDL training courses and multimedia training products available. Contact Electronics Workbench, or visit their Web page at www.interactiv.com for more information.

You will also find it useful to study, copy and modify existing VHDL design examples. “A.4 Examples Gallery” on page A-23 includes listings and descriptions of sample designs, and additional examples are provided on your Multisim’s VHDL installation CD-ROM.

A.4 Examples Gallery

The examples in this section are intended to help you get started with VHDL. Each example demonstrates one or more important features of the language, and demonstrates commonly used coding styles for synthesizable circuits and test benches. These examples, and more, can be found in the \EXAMPLES folder of your VHDL installation. You are encouraged to copy these examples and modify them for your own use.

A.4.1 Using Type Version Functions

This example, an 8-bit counter, demonstrates one possible approach to type conversion. Type conversions are often required in VHDL due to the languages’ strict type-checking features. In this example, a type conversion is required to convert the array data types used in the design’s interface to integer data types used internally for arithmetic operations. For demonstration purposes, we are using a custom type conversion function that is defined in the design description. In most cases, you will want to use a standard type conversion function from the IEEE library, or use a type conversion function provided by your synthesis vendor.

Note Another option when numeric values are required is to make use of the IEEE 1076.3 numeric_std package. This package is provided in the library IEEE supplied with the Multisim VHDL simulator.

A.4.1.1 Design Description

```

library ieee;
use ieee.std_logic_1164.all;

package conversions is
    function to_unsigned (a: std_ulogic_vector) return integer;
    function to_vector (size: integer; num: integer) return
std_ulogic_vector;
end conversions;

package body conversions is
-----
-- Convert a std_ulogic_vector to an unsigned integer --
    function to_unsigned (a: std_ulogic_vector) return integer is
        alias av: std_ulogic_vector (1 to a'length) is a;
        variable ret,d: integer;
    begin
        d := 1;
        ret := 0;
        for i in a'length downto 1 loop
            if (av(i) = '1') then
                ret := ret + d;
            end if;
            d := d * 2;
        end loop;
        return ret;
    end to_unsigned;

-----
-- Convert an integer to a std_ulogic_vector --
    function to_vector (size: integer; num: integer) return
std_ulogic_vector is
        variable ret: std_ulogic_vector (1 to size);
        variable a: integer;
    begin
        a := num;
        for i in size downto 1 loop
            if ((a mod 2) = 1) then
                ret(i) := '1';
            end if;
            a := a / 2;
        end loop;
        return ret;
    end to_vector;
end body conversions;

```

```

        else
            ret(i) := '0';
        end if;
        a := a / 2;
    end loop;
    return ret;
end to_vector;

end conversions;

-----
-- COUNT16: 4-bit counter.--
Library ieee;
Use ieee.std_logic_1164.all;
use work.conversions.all;

Entity COUNT16 Is
    Port (Clk,Rst,Load: in std_ulogic;
          Data: in std_ulogic_vector(3 downto 0);
          Count: out std_ulogic_vector(3 downto 0)
    );
End COUNT16;

Architecture COUNT16_A of COUNT16 Is
Begin
    process(Rst,Clk)

-- Note the use of a variable to localize the feedback behavior of the
-- counter registers. This is good general design practice in VHDL, as it
-- helps to cut down on unwanted side-effects. In this example, the use
-- of a variable of type integer also localizes the use of a numeric data
-- type to within the process itself. This makes it easier to modify the
-- design as necessary when using different type conversion routines.

        variable Q: integer range 0 to 15;

    begin

        if Rst = '1' then          -- Asynchronous reset
            Q := 0;
        elsif rising_edge(Clk) then
            if Load = '1' then
                Q := to_unsigned(Data); -- Convert vector to integer
            elsif Q = 15 then
                Q := 0;
            else

```

```

        Q := Q + 1;
    end if;
end if;

    Count <= to_vector(4,Q);
-- Convert integer to vector for use outside the process.

    end process;

End COUNT16_A;

```

A.4.1.2 Test Bench

```

library ieee;
Use ieee.std_logic_1164.all;

Entity T_COUNT16 Is
End T_COUNT16;

use work.count16;

Architecture stimulus of T_COUNT16 Is
    Component COUNT16
        Port (Clk,Rst,Load: in std_ulogic;
              Data: in std_ulogic_vector(3 downto 0);
              Count: out std_ulogic_vector(3 downto 0)
        );
    End Component;
    Signal Clk,Rst,Load: std_ulogic; -- Top level signals
    Signal Data: std_ulogic_vector(3 downto 0);
    Signal Count: std_ulogic_vector(3 downto 0);
    Signal Clock_cycle: natural := 0;

Begin
    DUT: COUNT16 Port Map (Clk,Rst,Load,Data,Count);

-- The first process sets up a 20Mhz background clock
    CLOCK: process
    begin
        Clock_cycle <= Clock_cycle + 1;
        Clk <= '1';
        wait for 25 ns;
        Clk <= '0';
        wait for 25 ns;
    end process;

```

```

end process;

-- This process applies stimulus to reset and load the counter...
Stimulus1: Process
Begin

    Rst <= '1';
    wait for 40 ns;
    Rst <= '0';
    Load <= '1';
    Data <= "0100";    -- Load 0100 into the counter
    wait for 50 ns;
    Load <= '0';
    wait for 500 ns;
    Load <= '1';
    Data <= "0000";    -- Load 0000 into the counter
    wait for 50 ns;
    Load <= '0';
    wait for 11000 ns;
    wait;
End Process;

End stimulus;

```

A.4.2 Describing a State Machine

This example demonstrates how to write a synthesizable state machine description using processes and enumerated types.

The circuit, a video frame grabber controller, was first described in *Practical Design Using Programmable Logic* by David Pellerin and Michael Holley (Prentice Hall, 1990). A slightly modified form of the circuit also appears in the *ATMEL Configurable Logic Design and Application Book*, 1993-1994 edition.

The circuit described is a simple freeze-frame unit that 'grabs' and holds a single frame of NTSC color video image. This design description includes the frame detection and capture logic. The complete circuit requires an 8-bit D-A/A-D converter and a 256K X 8 static RAM.

A.4.2.1 Design Description

```

-----
-- A Video Frame Grabber. --
Library ieee;
Use ieee.std_logic_1164.all;

```

```

Entity CONTROL Is
  Port (Reset: in std_ulogic;
        Clk: in std_ulogic;
        Mode: in std_ulogic;
        Data: in std_ulogic_vector(7 downto 0);
        TestLoad: in std_ulogic;
        Addr: out integer range 0 to 253243;
        RAMWE: out std_ulogic;
        RAMOE: out std_ulogic;
        ADOE: out std_ulogic );
End CONTROL;

Architecture CONTROL_A of CONTROL Is
  constant FRAMESIZE: integer := 253243;
  constant TESTADDR: integer := 253000;

  signal ENDFR: std_ulogic;
  signal INCAD: std_ulogic;
  signal VS: std_ulogic;
  signal Sync: integer range 0 to 127;
  type states is (StateLive,StateWait,StateSample,StateDisplay);
  signal current_state, next_state: states;
Begin

  -- Address counter. This counter increments until we reach the end of
  the frame (address 253243), or until the input INCAD goes low.

  ADDRCTR: process(Clk)
    variable cnt: integer range 0 to FRAMESIZE;
  begin
    if rising_edge(Clk) then
      if TestLoad = '1' then
        cnt := TESTADDR;
        ENDFR <= '0';
      else
        if INCAD = '0' or cnt = FRAMESIZE then
          cnt := 0;
        else
          cnt := cnt + 1;
        end if;
        if cnt = FRAMESIZE then
          ENDFR <= '1';
        else
          ENDFR <= '0';
        end if;
      end if;
    end if;
  end process ADDRCTR;

```

```

        end if;
    end if;
    Addr <= cnt;
end process;

-- Vertical sync detector. Here we look for 128 bits of zero, which
indicates the vertical sync blanking interval.

SYNCCTR: process(Reset, Clk)
begin
    if Reset = '1' then
        Sync <= 0;
    elsif rising_edge(Clk) then
        if Data /= "00000000" or Sync = 127 then
            Sync <= 0;
        else
            Sync <= Sync + 1;
        end if;
    end if;
end process;

VS <= '1' when Sync = 127 else '0';

-- State register process:

STREG: process(Reset, Clk)
begin
    if Reset = '1' then
        current_state <= StateLive;
    elsif rising_edge(Clk) then
        current_state <= next_state;
    end if;
end process;

-- State transitions:

STTRANS: process(current_state, Mode, VS, ENDFR)
begin
    case current_state is
        when StateLive => -- Display live video on the output
            RAMWE <= '1';
            RAMOE <= '1';
            ADOE <= '0';
            INCAD <= '0';
    end case;
end process;

```

```

        if Mode = '1' then
            next_state <= StateWait;
        end if;
    when StateWait => -- Wait for vertical sync
        RAMWE <= '1';
        RAMOE <= '1';
        ADOE <= '0';
        INCAD <= '0';
        if VS = '1' then
            next_state <= StateSample;
        end if;
    when StateSample => -- Sample one frame of video
        RAMWE <= '0';
        RAMOE <= '1';
        ADOE <= '0';
        INCAD <= '1';
        if ENDFR = '1' then
            next_state <= StateDisplay;
        end if;
    when StateDisplay => -- Display the stored frame
        RAMWE <= '1';
        RAMOE <= '0';
        ADOE <= '1';
        INCAD <= '1';
        if Mode = '1' then
            next_state <= StateLive;
        end if;
    end case;
end process;

End CONTROL_A;

```

A.4.2.2 Test Bench

The following test bench uses loops to simplify the description of a long test sequence:

```

library ieee;
Use ieee.std_logic_1164.all;
Use std.textio.all;

library work;
use work.control;

Entity T_CONTROL Is

```



```
End T_CONTROL;
```

Architecture stimulus of T_CONTROL Is

Component CONTROL

```
    Port (Reset: in std_ulogic;
          Clk: in std_ulogic;
          Mode: in std_ulogic;
          Data: in std_ulogic_vector(7 downto 0);
          TestLoad: in std_ulogic;
          Addr: out integer range 0 to 253243;
          RAMWE: out std_ulogic;
          RAMOE: out std_ulogic;
          ADOE: out std_ulogic);
End Component;
```

```
Constant PERIOD: time := 100 ns;
-- Top level signals go here...
Signal Reset: std_ulogic;
Signal Clk: std_ulogic;
Signal Mode: std_ulogic;
Signal Data: std_ulogic_vector(7 downto 0);
Signal TestLoad: std_ulogic;
Signal Addr: integer range 0 to 253243;
Signal RAMWE: std_ulogic;
Signal RAMOE: std_ulogic;
Signal ADOE: std_ulogic;
Signal done: boolean := false;
```

Begin

```
    DUT: CONTROL Port Map (
        Reset => Reset,
        Clk => Clk,
        Mode => Mode,
        Data => Data,
        TestLoad => TestLoad,
        Addr => Addr,
        RAMWE => RAMWE,
        RAMOE => RAMOE,
        ADOE => ADOE
    );
```

```
    Clock1: process
        variable clktmp: std_ulogic := '0';
    begin
        wait for PERIOD/2;
        clktmp := not clktmp;
        Clk <= clktmp; -- Attach your clock here
```

VHDL Primer

```
        if done = true then
            wait;
        end if;
    end process;

    Stimulus1: Process
    Begin
        -- Sequential stimulus goes here...
        Reset <= '1';
        Mode <= '0';
        Data <= "00000000";
        TestLoad <= '0';
        wait for PERIOD;
        Reset <= '0';
        wait for PERIOD;
        Data <= "00000001";
        wait for PERIOD;
        Mode <= '1';

        -- Check to make sure we detect the vertical sync...
        Data <= "00000000";
        for i in 0 to 127 loop
            wait for PERIOD;
        end loop;

        -- Now sample data to make sure the frame counter works...
        Data <= "01010101";
        for i in 0 to 100000 loop
            wait for PERIOD;
        end loop;

        -- Load in the test value to check the end of frame detection...
        TestLoad <= '1';
        wait for PERIOD;
        TestLoad <= '0';
        for i in 0 to 300 loop
            wait for PERIOD;
        end loop;
        done <= true;

    End Process;

End stimulus;
```

A.4.3 Reading and Writing from Files

More complex test benches often make use of VHDL's file read and write capabilities. These features make it easy to create test benches that operate on data stored in files, such as test vectors. The following example demonstrates how you can use the text I/O features of VHDL to read test data from an ASCII file.

Consider a Fibonacci sequence generator. A Fibonacci sequence is a series of numbers, beginning with 1, 1, 2, 3, 5..., in which every number in the sequence is the sum of the previous two numbers. To construct a circuit that generates an n -bit Fibonacci sequence, two n -bit registers — A and B — are required to store the last two values of the sequence and add them to produce the next value.

To initialize the circuit, the A and B registers must be loaded with values of 0 and 1 respectively. Subsequent cycles of the circuit must move the calculated next value into the B register while moving the value stored in the B register to the A register. In this implementation, the A and B registers form a 2-deep first-in first-out (FIFO) stack.

The VHDL source file shown below describes this Fibonacci sequence generator.

A.4.3.1 Design Description

```
-----
-- Fibonacci sequence generator.--
-- Copyright 1996, Accolade Design Automation, Inc.--

library ieee;
use ieee.std_logic_1164.all;

entity fib is
  port (Clk,Clr: in std_ulogic;
        Load: in std_ulogic;
        Data_in: in std_ulogic_vector(15 downto 0);
        S: out std_ulogic_vector(15 downto 0));
end fib;

architecture behavior of fib is
  signal Restart,Cout: std_ulogic;
  signal Stmp: std_ulogic_vector(15 downto 0);
  signal A, B, C: std_ulogic_vector(15 downto 0);
  signal Zero: std_ulogic;
  signal CarryIn, CarryOut: std_ulogic_vector(15 downto 0);

begin
  P1: process(Clk)
  begin
```

```

        if rising_edge(Clk) then
            Restart <= Cout;
        end if;
    end process;

    Stmp <= A xor B xor CarryIn;
    Zero <= '1' when Stmp = "0000000000000000" else '0';

    CarryIn <= C(15 downto 1) & '0';
    CarryOut <= (B and A) or ((B or A) and CarryIn);
    C(15 downto 1) <= CarryOut(14 downto 0);
    Cout <= CarryOut(15);

    P2: process(Clk,Clr,Restart)
    begin
        if Clr = '1' or Restart = '1' then
            A <= "0000000000000000";
            B <= "0000000000000000";
        elsif rising_edge(Clk) then
            if Load = '1' then
                A <= Data_in;
            elsif Zero = '1' then
                A <= "0000000000000001";
            else
                A <= B;
            end if;
            B <= Stmp;
        end if;
    end process;

    S <= Stmp;

end behavior;

```

A.4.3.2 Test Bench

The following test bench reads lines from an ASCII file and applies the data contained in each line as a test vector to stimulate and test the Fibonacci circuit:

```

-- Test bench for Fibonacci sequence generator.

library ieee;
use ieee.std_logic_1164.all;
use std.textio.all; -- Use the text I/O features of the standard
library

```

```
use work.fib;          -- Get the design out of library 'work'

entity testfib is     -- Entity; once again we have no ports
end testfib;

architecture stimulus of testfib is
  component fib      -- Create one instance of the fib design unit
  port (Clk,Clr: in std_ulogic;
        Load: in std_ulogic;
        Data_in: in std_ulogic_vector(15 downto 0);
        S: out std_ulogic_vector(15 downto 0));
  end component;

  -- The following conversion functions are used to process the test
  data and convert from string data to array data...
  function str2vec(str: string) return std_ulogic_vector is
  variable vtmp: std_ulogic_vector(str'range);
  begin
    for i in str'range loop
      if (str(i) = '1') then
        vtmp(i) := '1';
      elsif (str(i) = '0') then
        vtmp(i) := '0';
      else
        vtmp(i) := 'X';
      end if;
    end loop;
    return vtmp;
  end;

  function vec2str(vec: std_ulogic_vector) return string is
  variable stmp: string(vec'left+1 downto 1);
  begin
    for i in vec'reverse_range loop
      if (vec(i) = '1') then
        stmp(i+1) := '1';
      elsif (vec(i) = '0') then
        stmp(i+1) := '0';
      else
        stmp(i+1) := 'X';
      end if;
    end loop;
    return stmp;
  end;
```

VHDL Primer

```

    signal Clk,Clr: std_ulogic;          -- Declare local signals
    signal Load: std_ulogic;
    signal Data_in: std_ulogic_vector(15 downto 0);
    signal S: std_ulogic_vector(15 downto 0);
    signal done: std_ulogic := '0';

    constant PERIOD: time := 50 ns;
    for DUT: fib use entity work.fib(behavior);    -- Configuration
specification
begin
    DUT: fib port map(Clk=>Clk,Clr=>Clr,Load=>Load,-- Creates one
                    Data_in=>Data_in,S=>S);          instance

    Clock: process
        variable c: std_ulogic := '0';-- Background clock process
    begin
        while (done = '0') loop -- The done flag indicates that we
            wait for PERIOD/2;    are finished and can stop the clock.
            c := not c;
            Clk <= c;
        end loop;
    end process;

    read_input: process
        file vector_file: text is in "testfib.vec";-- File declaration

        variable stimulus_in: std_ulogic_vector(33 downto 0);
            -- Temporary storage for inputs

        variable S_expected: std_ulogic_vector(15 downto 0);
            -- Temporary storage for outputs

        variable str_stimulus_in: string(34 downto 1);
            -- Temporary storage for big string

        variable err_cnt: integer := 0;
        variable file_line: line;
            -- Keeps track of how many errors Text
line buffer; 'line' is a standard type (textio library).

    begin
        wait until rising_edge(Clk);    -- Synchronizes with first clock

        while not endfile(vector_file) loop-- Loops through the lines in
            the file

```

```

        readline (vector_file,file_line);-- Reads one complete line
                                         into file_line

        read (file_line,str_stimulus_in);-- Extracts the first field
from file_line

        stimulus_in := str2vec(str_stimulus_in);-- Converts the input
string to a vector

        wait for 1 ns;          -- Delays for a nanosecond

        Clr <= stimulus_in(33);  -- Gets each input's
Load <= stimulus_in(32);  -- value from the test
Data_in <= stimulus_in(31 downto 16);-- vector array and
assigns the values

        S_expected := stimulus_in(15 downto 0);

        wait until falling_edge(Clk);-- Waits until the clock goes
                                         back to '0' (midway through the clock
cycle)

        if (S /= S_expected) then
            err_cnt := err_cnt + 1;
            assert false -- Increments the error counter and
reports an error if different
                report "Vector failure!" & lf &
                    "Expected S to be " & vec2str(S_expected) & lf &
                    "but its value was " & vec2str(S) & lf
                    severity note;
        end if;
    end loop;          -- Continues looping through the file

    done <= '1';      -- Sets a flag when we are finished; this
will stop the clock.

    wait;            -- Suspends the simulation

end process;

end stimulus;

```

Appendix B.1

Verilog HDL Primer

| | |
|----------------------------------------------------------------------|----|
| B.1.1 Introduction | 1 |
| B.1.1.1 What is Verilog? | 1 |
| B.1.1.2 Why Use Verilog HDL? | 2 |
| B.1.2 The Verilog Language | 3 |
| B.1.2.1 A First Verilog Program | 3 |
| B.1.2.2 Lexical Conventions | 5 |
| B.1.2.3 Program Structure | 6 |
| B.1.2.4 Data Types | 9 |
| B.1.2.4.1 Physical Data Types | 9 |
| B.1.2.4.2 Abstract Data Types | 10 |
| B.1.2.5 Operators | 11 |
| B.1.2.5.1 Binary Arithmetic Operators | 11 |
| B.1.2.5.2 Unary Arithmetic Operators | 11 |
| B.1.2.5.3 Relational Operators | 11 |
| B.1.2.5.4 Logical Operators | 11 |
| B.1.2.5.5 Bitwise Operators | 12 |
| B.1.2.5.6 Unary Reduction Operators | 12 |
| B.1.2.5.7 Other Operators | 12 |
| B.1.2.5.8 Operator Precedence | 13 |
| B.1.2.6 Control Constructs | 13 |
| B.1.2.6.1 Selection - if and case Statements | 14 |
| B.1.2.6.2 Repetition - for, while and repeat Statements | 14 |
| B.1.2.7 Other Statements | 15 |
| B.1.2.7.1 Parameter Statement | 15 |
| B.1.2.7.2 Continuous Assignment | 15 |
| B.1.2.7.3 Blocking and Non-blocking Procedural Assignments | 15 |
| B.1.2.8 Tasks and Functions | 16 |
| B.1.2.9 Timing Control | 18 |
| B.1.2.9.1 Delay Control (#) | 19 |
| B.1.2.9.2 Events | 19 |
| B.1.2.9.3 wait Statement | 20 |
| B.1.2.9.4 fork and join Statements | 20 |
| B.1.2.9.5 Traffic Light Example | 21 |
| B.1.3 System Tasks and Functions | 23 |
| B.1.3.1 \$cleartrace | 23 |
| B.1.3.2 \$display | 23 |

| | |
|-------------------------------|----|
| B.1.3.3\$finish | 24 |
| B.1.3.4\$monitor | 24 |
| B.1.3.5\$scope | 25 |
| B.1.3.6\$settrace | 25 |
| B.1.3.7\$showscopes | 25 |
| B.1.3.8\$showvars | 25 |
| B.1.3.9\$stop | 26 |
| B.1.3.10\$time | 26 |

Appendix B.1 Verilog HDL Primer

Forward

Electronics Workbench would like to thank Dr. Daniel C. Hyde of the Computer Science Department, Bucknell University, Lewisburg, PA, for allowing us to use his Handbook on Verilog HDL, (Dated August 25, 1997). Dr. Hydes' handbook, which has been incorporated into this primer, provides an entry level discussion on Verilog HDL and its capabilities.

B.1.1 Introduction

Verilog HDL is a **Hardware Description Language (HDL)**. A Hardware Description Language is a language used to describe a digital system, for example, a computer or a component of a computer. One may describe a digital system at several levels. For example, an HDL might describe the layout of the wires, resistors and transistors on an **Integrated Circuit (IC)** chip, i.e., the **switch level**. Or, it might describe the logical gates and flip flops in a digital system, i.e., the **gate level**. An even higher level describes the registers and the transfers of vectors of information between registers. This is called the **Register Transfer Level (RTL)**. Verilog supports all of these levels. However, this primer focuses on only the portions of Verilog which support the RTL level.

B.1.1.1 What is Verilog?

Verilog is one of the two major Hardware Description Languages (HDL) used by hardware designers in industry and academia. VHDL is the other one. The industry is currently split on which is better. Many feel that Verilog is easier to learn and use than VHDL. VHDL was made an IEEE Standard in 1987, and Verilog in 1995. Verilog is very C-like and liked by electrical and computer engineers as most learn the C language in college. VHDL is very Ada-like and most engineers have no experience with Ada.

Verilog was introduced in 1985 by Gateway Design System Corporation, now a part of Cadence Design Systems, Inc.'s Systems Division. Until May, 1990, with the formation of

Open Verilog International (OVI), Verilog HDL was a proprietary language of Cadence. Cadence was motivated to open the language to the Public Domain with the expectation that the market for Verilog HDL-related software products would grow more rapidly with broader acceptance of the language. Cadence realized that Verilog HDL users wanted other software and service companies to embrace the language and develop Verilog-supported design tools. Verilog HDL allows a hardware designer to describe designs at a high level of abstraction such as at the architectural or behavioral level as well as the lower implementation levels (i.e. gate and switch levels) leading to Very Large Scale Integration (VLSI) Integrated Circuits (IC) layouts and chip fabrication. A primary use of HDLs is the simulation of designs before the designer must commit to fabrication. This primer does not cover all of Verilog HDL but focuses on the use of Verilog HDL at the architectural or behavioral levels. The primer emphasizes design at the Register Transfer Level (RTL).

B.1.1.2 Why Use Verilog HDL?

Digital systems are highly complex. At their most detailed level, they may consist of millions of elements, i.e., transistors or logic gates. Therefore, for large digital systems, gate-level design is dead. For many decades, logic schematics served as the *lingua franca* of logic design, but not any more. Today, hardware complexity has grown to such a degree that a schematic with logic gates is almost useless as it shows only a web of connectivity and not the functionality of design. Since the 1970s, Computer engineers and electrical engineers have moved toward hardware description languages (HDLs). The most prominent modern HDLs in industry are Verilog and VHDL. Verilog is the top HDL used by over 10,000 designers at such hardware vendors as Sun Microsystems, Apple Computer and Motorola. Industrial designers like Verilog. It works.

The Verilog language provides the digital designer with a means of describing a digital system at a wide range of levels of abstraction, and, at the same time, provides access to computer-aided design tools to aid in the design process at these levels.

Verilog allows hardware designers to express their design with **behavioral constructs**, deterring the details of implementation to a later stage of design in the design. An abstract representation helps the designer explore architectural alternatives through **simulations** and to detect design bottlenecks before detailed design begins.

Though the behavioral level of Verilog is a high level description of a digital system, it is still a precise notation. Computer-aided-design tools, i.e., programs, exist which will "compile" programs in the Verilog notation to the level of circuits consisting of logic gates and flip flops. One could then go to the lab and wire up the logical circuits and have a functioning system.

And, other tools can "compile" programs in Verilog notation to a description of the integrated circuit masks for **very large scale integration** (VLSI). Therefore, with the proper automated tools, one can create a VLSI description of a design in Verilog in a few weeks. Verilog also allows the designer to specify designs at the logical gate level using **gate constructs** and the transistor level using **switch constructs**.

B.1.2 The Verilog Language

There is no attempt in this primer to describe the complete Verilog language. It describes only the portions of the language needed to allow you to explore the architectural aspects of computers. In fact, this primer covers only a small fraction of the language. For the complete description of the Verilog HDL, consult the references in the Multisim help files.

We begin our study of the Verilog language by looking at a simple Verilog program. Looking at the assignment statements, we notice that the language is very C-like. Comments have a C++ flavor, i.e., they are shown by "/" to the end of the line. The Verilog language describes a digital system as a set of **modules**, but here we have only a single module called "simple".

B.1.2.1 A First Verilog Program

```
//By Dan Hyde; August 9, 1995
//A first digital model in Verilog

module simple;
// Simple Register Transfer Level (RTL) example to demo Verilog.
// Register A is incremented by one. Then first four bits of B is
// set to "not" of the last four bits of A. C is the "and"
// reduction of the last two bits of A.

//declare registers and flip-flops
reg [0:7] A, B;
reg      C;

// The two "initial"s and "always" will run concurrently
initial begin: stop_at
    // Will stop the execution after 20 simulation units.
    #20; $stop;
end

// These statements done at simulation time 0 (since no #k)
initial begin: Init
    // Initialize register A. Other registers have values of "x"
```

```

    A = 0;

    // Display a header
    $display("Time   A           B   C");

    // Prints the values anytime a value of A, B or C changes
    $monitor(" %0d %b %b %b", $time, A, B, C);
end

//main_process will loop until simulation is over
always begin: main_process

    // #1 means do after one unit of simulation time
    #1 A = A + 1;
    #1 B[0:3] = ~A[4:7]; // ~ is bitwise "not" operator
    #1 C = &A[6:7];      // bitwise "and" reduction of last 2 bits
of A

end

endmodule

```

In **module simple**, we declared **A** and **B** as 8-bit registers and **C** a 1-bit register or flip-flop. Inside of the module, the one “**always**” and two “**initial**” constructs describe three **threads of control**, i.e., they run at the same time or **concurrently**. Within the **initial** construct, statements are executed sequentially much like in C or other traditional imperative programming languages. The **always** construct is the same as the **initial** construct except that it loops forever as long as the simulation runs.

The notation **#1** means to execute the statement after delay of one unit of simulated time. Therefore, the thread of control caused by the first **initial** construct will delay for 20 time units before calling the system task **\$stop** and stop the simulation.

The **\$display** system task allows the designer to print a message much like **printf** does in the language C. Every time unit that one of the listed variable’s value changes, the **\$monitor** system task prints a message. The system function **\$time** returns the current value of simulated time.

Below is the output:

```

Time   A           B   C
  0 00000000 xxxxxxxx x
  1 00000001 xxxxxxxx x
  2 00000001 1110xxxx x
  3 00000001 1110xxxx 0
  4 00000010 1110xxxx 0
  5 00000010 1101xxxx 0

```

```

7 00000011 1101xxxx 0
8 00000011 1100xxxx 0
9 00000011 1100xxxx 1
10 00000100 1100xxxx 1
11 00000100 1011xxxx 1
12 00000100 1011xxxx 0
13 00000101 1011xxxx 0
14 00000101 1010xxxx 0
16 00000110 1010xxxx 0
17 00000110 1001xxxx 0
19 00000111 1001xxxx 0
Stop at simulation time 20

```

You should carefully study the program and its output before going on. The structure of the program is typical of the Verilog programs you will write for this course, i.e., an **initial** construct to specify the length of the simulation, another **initial** construct to initialize registers and specify which registers to monitor and an **always** construct for the digital system you are modeling. Notice that all the statements in the second **initial** are done at time = 0, since there are no delay statements, i.e., **#<integer>**.

B.1.2.2 Lexical Conventions

The lexical conventions are close to the programming language C++. Comments are designated by **//** to the end of a line or by **/*** to ***/** across several lines. Keywords, e.g., **module**, are reserved and in all lower case letters. The language is case sensitive, meaning upper and lower case letters are different. Spaces are important in that they delimit tokens in the language.

Numbers are specified in the traditional form of a series of digits with or without a sign but also in the following form:

```
<size><base format><number>
```

where **<size>** contains decimal digits that specify the size of the constant in the number of bits. The **<size>** is optional. The **<base format>** is the single character ' followed by one of the following characters **b**, **d**, **o** and **h**, which stand for binary, decimal, octal and hex, respectively. The **<number>** part contains digits which are legal for the **<base format>**. Some examples:

```

549          // decimal number
'h 8FF      // hex number
'o765      // octal number
4'b11      // 4-bit binary number 0011
3'b10x     // 3-bit binary number with least
           // significant bit unknown
5'd3       // 5-bit decimal number
-4'b11     // 4-bit two's complement of 0011 or 1101

```

The <number> part may not contain a sign. Any sign must go on the front.

A string is a sequence of characters enclosed in double quotes.

```
"this is a string"
```

Operators are one, two or three characters and are used in expressions (see “B.1.2.5 Operators” on page B.1-11).

An identifier is specified by a letter or underscore followed by zero or more letters, digits, dollar signs and underscores. Identifiers can be up to 1024 characters.

B.1.2.3 Program Structure

The Verilog language describes a digital system as a set of modules. Each of these modules has an interface to other modules to describe how they are interconnected. Usually we place one module per file but that is not a requirement. The modules may run concurrently, but usually we have one top level module which specifies a closed system containing both test data and hardware models. The top level module invokes instances of other modules.

Modules can represent pieces of hardware ranging from simple gates to complete systems, e.g., a microprocessor. Modules can either be specified behaviorally or structurally (or a combination of the two). A **behavioral specification** defines the behavior of a digital system (module) using traditional programming language constructs, e.g., **ifs**, assignment statements. A **structural specification** expresses the behavior of a digital system (module) as a hierarchical interconnection of sub modules. At the bottom of the hierarchy the components must be primitives or specified behaviorally. Verilog primitives include gates, e.g., nand, as well as pass transistors (switches).

The structure of a module is the following:

```
module <module name> (<port list>);  
  <declares>  
  <module items>  
endmodule
```

The <module name> is an identifier that uniquely names the module. The <port list> is a list of input, inout and output ports which are used to connect to other modules. The <declares> section specifies data objects as registers, memories and wires as well as procedural constructs such as **functions** and **tasks**.

The <module items> may be **initial** constructs, **always** constructs, continuous assignments or instances of modules.

The semantics of the **module** construct in Verilog is very different from subroutines, procedures and functions in other languages. A module is never called! A module is instantiated at the start of the program and stays around for the life of the program. A Verilog module instantiation is used to model a hardware circuit where we assume no one unsolders or changes the

wiring. Each time a module is instantiated, we give its instantiation a name. For example, **NAND1** and **NAND2** are the names of instantiations of our **NAND** gate in the example below.

Here is a behavior specification of a module **NAND**. The output **out** is the **not** of the **and** of the inputs **in1** and **in2**.

```
// Behavioral Model of a Nand gate
// By Dan Hyde, August 9, 1995
module NAND(in1, in2, out);

    input in1, in2;
    output out;
        // continuous assign statement
    assign out = ~(in1 & in2);

endmodule
```

The ports **in1**, **in2** and **out** are labels on wires. The continuous assignment **assign** continuously watches for changes to variables in its right hand side and whenever that happens the right hand side is re-evaluated and the result immediately propagated to the left hand side (**out**).

The continuous assignment statement is used to model **combinational circuits** where the outputs change when one wiggles the input.

Here is a structural specification of a module **AND** obtained by connecting the output of one **NAND** to both inputs of another one.

```
module AND(in1, in2, out);
// Structural model of AND gate from two NANDS
    input in1, in2;
    output out;
    wire w1;
        // two instantiations of the module NAND
    NAND NAND1(in1, in2, w1);
    NAND NAND2(w1, w1, out);

endmodule
```

This module has two instances of the **NAND** module called **NAND1** and **NAND2** connected together by an internal wire **w1**.

The general form to invoke an instance of a module is :

```
<module name> <parameter list> <instance name> (<port list>);
```

where **<parameter list>** are values of parameters passed to the instance. An example parameter passed would be the delay for a gate.

The following module is a high level module which sets some test data and sets up the monitoring of variables.

```

module test_AND;
// High level module to test the two other modules
  reg a, b;
  wire out1, out2;

  initial begin // Test data
    a = 0; b = 0;
    #1 a = 1;
    #1 b = 1;
    #1 a = 0;
  end

  initial begin // Set up monitoring
    $monitor("Time=%0d a=%b b=%b out1=%b out2=%b",
             $time, a, b, out1, out2);
  end

  // Instances of modules AND and NAND
  AND gate1(a, b, out2);
  NAND gate2(a, b, out1);

endmodule

```

Notice that we need to hold the values **a** and **b** over time. Therefore, we had to use 1-bit registers. **reg** variables store the last value that was *procedurally assigned* to them (just like variables in traditional imperative programming languages). **wires** have no storage capacity. They can be continuously driven, e.g., with a continuous **assign** statement or by the output of a module, or if input wires are left unconnected, they get the special value of x for unknown.

Continuous assignments use the keyword **assign** whereas procedural assignments have the form **<reg variable> = <expression>** where the **<reg variable>** must be a register or memory. Procedural assignment may only appear in **initial** and **always** constructs.

The statements in the block of the first **initial** construct will be executed sequentially, some of which are delayed by #1, i.e., one unit of simulated time. The **always** construct behaves the same as the **initial** construct except that it loops forever (until the simulation stops). The **initial** and **always** constructs are used to model **sequential logic** (i.e., **finite state automata**).

Verilog makes an important distinction between procedural assignment and the continuous assignment **assign**. Procedural assignment changes the state of a register, i.e., *sequential logic*, whereas the continuous statement is used to model **combinational logic**. Continuous assignments drive **wire** variables and are evaluated and updated whenever an input operand changes value. It is important to understand and remember the difference.

We place all three modules in a file and run the simulator to produce the following output.

```
Time=0 a=0 b=0 out1=1 out2=0
Time=1 a=1 b=0 out1=1 out2=0
Time=2 a=1 b=1 out1=0 out2=1
Time=3 a=0 b=1 out1=1 out2=0
```

Since the simulator ran out of events, I didn't need to explicitly stop the simulation.

B.1.2.4 Data Types

B.1.2.4.1 Physical Data Types

Since the purpose of Verilog HDL is to model digital hardware, the primary data types are for modeling registers (**reg**) and wires (**wire**). The **reg** variables store the last value that was procedurally assigned to them whereas the **wire** variables represent physical connections between structural entities such as gates. A **wire** does not store a value. A **wire** variable is really only a label on a wire. (Note that the **wire** data type is only one of several **net** data types in Verilog HDL which include “wired and” (**wand**), “wired or” (**wor**) and “tristate bus” (**tri**). This Primer is restricted to only the **wire** data type.)

The **reg** and **wire** data objects may have the following possible values:

```
0 logical zero or false
1 logical one or true
x unknown logical value
z high impedance of tristate gate
```

The **reg** variables are initialized to **x** at the start of the simulation. Any **wire** variable not connected to something has the **x** value.

You may specify the size of a register or wire in the declaration. For example, the declarations

```
reg [0:7] A, B;
wire [0:3] Dataout;
reg [7:0] C;
```

specify registers **A** and **B** to be 8-bit wide with the most significant bit the zeroth bit, whereas the most significant bit of register **C** is bit seven. The wire **Dataout** is 4 bits wide.

The bits in a register or wire can be referenced by the notation [**<start-bit>**:**<end-bit>**].

For example, in the second procedural assignment statement

```
initial begin: int1
    A = 8'b01011010;
    B = {A[0:3] | A[4:7], 4'b0000};
end
```

B is set to the first four bits of **A** bitwise or-ed with the last four bits of **A** and then concatenated with 0000. **B** now holds a value of 11110000. The {} brackets means the bits of the two or more arguments separated by commas are concatenated together.

An argument may be replicated by specifying a repetition number of the form:

```
{repetition_number{exp1, exp2, ... , expn}}
```

Here are some examples:

```
C = {2{4'b1011}}; //C assigned the bit vector 8'b10111011
C = {{4{A[4]}}, A[4:7]}; // first 4 bits are sign extension
```

The range referencing in an expression *must* have constant expression indices. However, a single bit may be referenced by a variable. For example:

```
reg [0:7] A, B;
B = 3;
A[0: B] = 3'b111; // ILLEGAL - indices MUST be constant!!
A[B] = 1'b1;      // A single bit reference is LEGAL
```

Why such a strict requirement of constant indices in register references? Since we are describing hardware, we want only expressions which are realizable.

Memories are specified as vectors of registers. For example, **Mem** is 1K words each 32-bits.

```
reg [31:0] Mem [0:1023];
```

The notation **Mem[0]** references the zeroth word of memory. The array index for memory (register vector) may be a register. Notice that one can *not* reference a memory at the bit-level in Verilog HDL. If you want a specific range of bits in a word of memory, you *must* first transfer the data in the word to a temporary register.

B.1.2.4.2 Abstract Data Types

In addition to modeling hardware, there are other uses for variables in a hardware model. For example, the designer might want to use an **integer** variable to count the number of times an event occurs. For the convenience of the designer, Verilog HDL has several data types which do not have a corresponding hardware realization. These data types include **integer**, **real** and **time**. The data types **integer** and **real** behave pretty much as in other languages, e.g., C. Be warned that a **reg** variable is unsigned and that an **integer** variable is a signed 32-bit integer. This has important consequences when you subtract.

time variables hold 64-bit quantities and are used in conjunction with the **\$time** system function. Arrays of **integer** and **time** variables (but not **reals**) are allowed. Multiple dimensional arrays are not allowed in Verilog HDL. Some examples:

```
integer Count;      // simple signed 32-bit integer
integer K[1:64];    // an array of 64 integers
time Start, Stop;  // Two 64-bit time variables
```

B.1.2.5 Operators

B.1.2.5.1 Binary Arithmetic Operators

Binary arithmetic operators operate on two operands. Register and net (wire) operands are treated as unsigned. However, real and integer operands may be signed. If any bit of an operand is unknown ('x') then the result is unknown.

| Operator | Name | Comments |
|----------|----------------|---------------------------------------------------------|
| + | Addition | |
| - | Subtraction | |
| * | Multiplication | |
| / | Division | Divide by zero produces an x , i.e., unknown. |
| % | Modulus | |

B.1.2.5.2 Unary Arithmetic Operators

| Operator | Name | Comments |
|----------|-------------|------------------------------|
| - | Unary Minus | Changes sign of its operand. |

B.1.2.5.3 Relational Operators

Relational operators compare two operands and return a logical value, i.e., TRUE(1) or FALSE(0). If any bit is unknown, the relation is ambiguous and the result is unknown.

| Operator | Name | Comments |
|----------|-----------------------|----------|
| > | Greater than | |
| >= | Greater than or equal | |
| < | Less than | |
| <= | Less than or equal | |
| == | Logical equality | |
| != | Logical inequality | |

B.1.2.5.4 Logical Operators

Logical operators operate on logical operands and return a logical value, i.e., TRUE(1) or FALSE(0). Used typically in **if** and **while** statements. Do not confuse logical operators with the bitwise Boolean operators. For example, **!** is a logical NOT and **~** is a bitwise NOT. The first negates, e.g., **!(5 == 6)** is TRUE. The second complements the bits, e.g., **~{1,0,1,1}** is 0100.

| Operator | Name | Comments |
|----------|------------------|----------|
| ! | Logical negation | |
| && | Logical AND | |
| | Logical OR | |

B.1.2.5.5 Bitwise Operators

Bitwise operators operate on the bits of the operand or operands. For example, the result of A & B is the AND of each corresponding bit of A with B. Operating on an unknown (x) bit results in the expected value. For example, the AND of an x with a FALSE is an x. The OR of an x with a TRUE is a TRUE.

| Operator | Name | Comments |
|----------|----------------------------|----------|
| ~ | Bitwise negation | |
| & | Bitwise AND | |
| | Bitwise OR | |
| ^ | Bitwise XOR | |
| ~& | Bitwise NAND | |
| ~ | Bitwise NOR | |
| ~^ or ^~ | EquivalenceBitwise NOT XOR | |

B.1.2.5.6 Unary Reduction Operators

Unary reduction operators produce a single bit result from applying the operator to all of the bits of the operand. For example, &A will AND all the bits of A.

| Operator | Name | Comments |
|----------|----------------|----------|
| & | AND reduction | |
| | OR reduction | |
| ^ | XOR reduction | |
| ~& | NAND reduction | |
| ~ | NOR reduction | |
| ~^ | XNOR reduction | |

B.1.2.5.7 Other Operators

The conditional operator operates much like in the language C.

| Operator | Name | Comments |
|----------|-----------------|------------------------------------------------------------------------------------------------------------------------------|
| === | Case equality | The bitwise comparison includes comparison of x and z values. All bits must match for equality. Returns TRUE or FALSE. |
| !== | Case inequality | The bitwise comparison includes comparison of x and z values. Any bit difference produces inequality. Returns TRUE or FALSE. |

| | | |
|-------|---------------|-----------------------------------------------------------------------------------------------------------------------------------------------------------------------|
| { , } | Concatenation | Joins bits together with 2 or more comma-separated expressions, e, g. {A[0], B[1:7]} concatenates the zeroth bit of A to bits 1 to 7 of B. |
| << | Shift left | Vacated bit positions are filled with zeros, e.g., A = A << 2; shifts A two bits to left with zero fill. |
| >> | Shift right | Vacated bit positions are filled with zeros. |
| ?: | Conditional | Assigns one of two values depending on the conditional expression. e.g., A = C > D ? B+3 : B-2; means if C greater than D, the value of A is B+3 otherwise B-2. |

B.1.2.5.8 Operator Precedence

The precedence of operators is shown below. The top of the table is the highest precedence and the bottom is the lowest. Operators on the same line have the same precedence and associate left to right in an expression. Parentheses can be used to change the precedence or clarify the situation. We strongly urge you to use parentheses to improve readability.

```

unary operators: !  &  ~&  |  ~|  ^  ~^  +  -  (highest precedence)
                *  /  %
                +  -
                <<  >>
                <  <=  >  >+
                ==  !=  ===  ~===
                &  ~&  ^  ~^
                |  ~|
                &&
                ||
                ?:

```

B.1.2.6.2.6 Control Constructs

Verilog HDL has a rich collection of control statements which can be used in the procedural sections of code, i.e., within an **initial** or **always** block. Most of them will be familiar to the programmer of traditional programming languages like C. The main difference is instead of C's { } brackets, Verilog HDL uses **begin** and **end**. In Verilog, the { } brackets are used for concatenation of bit strings. Since most users are familiar with C, the following subsections typically show only an example of each construct.

B.1.2.6.1 Selection - if and case Statements

The **if** statement is easy to use.

```
if (A == 4)
    begin
        B = 2;
    end
else
    begin
        B = 4;
    end
```

Unlike the **case** statement in C, the first <value> that matches the value of the <expression> is selected and the associated statement is executed then control is transferred to after the **endcase**, i.e., no **break** statements are needed as in C.

```
case (<expression>)
    <value1>: <statement>
    <value2>: <statement>
    default: <statement>
endcase
```

The following example checks a 1-bit signal for its value.

```
case (sig)
    1'bz: $display("Signal is floating");
    1'bx: $display("Signal is unknown");
    default: $display("Signal is %b", sig);
endcase
```

B.1.2.6.2 Repetition - for, while and repeat Statements

The **for** statement is very close to C's **for** statement except that the ++ and -- operators do not exist in Verilog. Therefore, we need to use **i = i + 1**.

```
for(i = 0; i < 10; i = i + 1)
    begin
        $display("i= %0d", i);
    end
```

The **while** statement acts in the normal fashion.

```
i = 0;
while(i < 10)
    begin
        $display("i= %0d", i);
        i = i + 1;
    end
```

The **repeat** statement repeats the following block a fixed number of times, in this example, five times.

```
repeat (5)
  begin
    $display("i= %0d", i);
    i = i + 1;
  end
```

B.1.2.7 Other Statements

B.1.2.7.1 Parameter Statement

The **parameter** statement allows the designer to give a constant a name. Typical uses are to specify width of registers and delays. For example, the following allows the designer to parameterized the declarations of a model.

```
parameter byte_size = 8;

reg [byte_size - 1:0] A, B;
```

B.1.2.7.2 Continuous Assignment

Continuous assignments drive **wire** variables and are evaluated and updated whenever an input operand changes value. The following **ands** the values on the wires **in1** and **in2** and drives the wire **out**. The keyword **assign** is used to distinguish the continuous assignment from the procedural assignment. See “B.1.2.3 Program Structure” on page B.1-6 for more discussion on continuous assignment.

```
assign out = ~(in1 & in2);
```

B.1.2.7.3 Blocking and Non-blocking Procedural Assignments

The Verilog language has two forms of the procedural assignment statement: blocking and non-blocking. The two are distinguished by the = and <= assignment operators. The blocking assignment statement (= operator) acts much like in traditional programming languages. The whole statement is done before control passes on to the next statement. The non-blocking (<= operator) evaluates all the right-hand sides *for the current time unit* and assigns the left-hand sides at the end of the time unit. For example, the following Verilog program

```
// testing blocking and non-blocking assignment
module blocking;
reg [0:7] A, B;
initial begin: init1
    A = 3;
    #1 A = A + 1;    // blocking procedural assignment
    B = A + 1;
    $display("Blocking:      A= %b B= %b", A, B );

    A = 3;
    #1 A <= A + 1;  // non-blocking procedural assignment
    B <= A + 1;

    #1 $display("Non-blocking: A= %b B= %b", A, B );
end

endmodule
```

produces the following output:

```
Blocking:      A= 00000100 B= 00000101
Non-blocking: A= 00000100 B= 00000100
```

The effect is for all the non-blocking assignments to use the old values of the variables at the beginning of the current time unit and to assign the registers new values at the end of the current time unit. This reflects how register transfers occur in some hardware systems.

B.1.2.8 Tasks and Functions

Tasks are like procedures in other programming languages, e.g., tasks may have zero or more arguments and do not return a value. **Functions** act like function subprograms in other languages. *Except:*

1. A Verilog function must execute during one simulation time unit. That is, no time controlling statements, i.e., no delay control (`#`), no event control (`@`) or `wait` statements, allowed. A task may contain time controlled statements.
2. A Verilog function *cannot* invoke (call, enable) a task; whereas a task may call other tasks and functions.

The definition of a task is the following:

```
task <task name>; // Notice: no parameter list or ()s
    <argument ports>
    <declarations>
    <statements>
endtask
```

An invocation of a task is of the following form:

```
<name of task> (<port list>);
```

where **<port list>** is a list of expressions which correspond by position to the **<argument ports>** of the definition. Port arguments in the definition may be **input**, **inout** or **output**. Since the **<argument ports>** in the task definition look like declarations, the programmer must be careful in adding declares at the beginning of a task.

```
// Testing tasks and functions
// Dan Hyde, Aug 28, 1995
module tasks;

task add;      // task definition
  input a, b;  // two input argument ports
  output c;    // one output argument port
  reg R;       // register declaration
begin
  R = 1;
  if (a == b)
    c = 1 & R;
  else
    c = 0;
end
endtask

initial begin: init1
  reg p;
  add(1, 0, p); // invocation of task with 3 arguments
  $display("p= %b", p);
end

endmodule
```

input and **inout** parameters are passed by value to the task and **output** and **inout** parameters are passed back to invocation by value on return. Call by reference is not available.

Allocation of all variables is static. Therefore, a task may call itself but each invocation of the task uses the same storage, i.e., the local variables are not pushed on a stack. Since concurrent threads may invoke the same task, the programmer must be aware of the static nature of storage and avoid unwanted overwriting of shared storage space.

The purpose of a function is to return a value that is to be used in an expression. A function definition must contain at least one **input** argument. The passing of arguments in functions is the same as with tasks (see above). The definition of a function is the following:

```
function <range or type> <function name>;// Notice: no parameter list
or ()s
    <argument ports>
    <declarations>
    <statements>
endfunction
```

where **<range or type>** is the type of the results passed back to the expression where the function was called. Inside the function, one must assign the function name a value. Below is a function which is similar to the task above.

```
// Testing functions
// Dan Hyde, Aug 28, 1995
module functions;

function [1:1] add2; // function definition
input a, b;         // two input argument ports
reg R;              // register declaration
begin
    R = 1;
    if (a == b)
        add2 = 1 & R;
    else
        add2 = 0;
    end
endfunction

initial begin: init1
    reg p;
    p = add2(1, 0); // invocation of function with 2 arguments
    $display("p= %b", p);
end

endmodule
```

B.1.2.9 Timing Control

The Verilog language provides two types of explicit timing control over when simulation time procedural statements are to occur. The first type is a **delay control** in which an expression specifies the time duration between initially encountering the statement and when the statement actually executes. The second type of timing control is the **event expression**, which allows statement execution. The third subsection describes the **wait** statement which waits for a specific variable to change.

Verilog is a **discrete event time simulator**, i.e., events are scheduled for discrete times and placed on an ordered-by-time wait queue. The earliest events are at the front of the wait queue and the later events are behind them. The simulator removes all the events for the current simulation time and processes them. During the processing, more events may be created and placed in the proper place in the queue for later processing. When all the events of the current time have been processed, the simulator advances time and processes the next events at the front of the queue.

If there is no timing control, simulation time does not advance. Simulated time can *only* progress by one of the following:

1. gate or wire delay, if specified.
2. a delay control, introduced by the # symbol.
3. an event control, introduced by the @ symbol.
4. the **wait** statement.

The order of execution of events in the same clock time may not be predictable.

B.1.2.9.1 Delay Control (#)

A **delay control** expression specifies the time duration between initially encountering the statement and when the statement actually executes. For example:

```
#10 A = A + 1;
```

specifies to delay 10 time units before executing the procedural assignment statement. The # may be followed by an expression with variables.

B.1.2.9.2 Events

The execution of a procedural statement can be triggered with a value change on a wire or register, or the occurrence of a named event. Some examples:

```
@r begin           // controlled by any value change in
  A = B&C;          // the register r
end
```

```
@(posedge clock2) A = B&C; // controlled by positive edge of clock2
```

```
@(negedge clock3) A = B&C; // controlled by negative edge of clock3
```

```
forever @(negedge clock) // controlled by negative edge
begin
  A = B&C;
end
```

In the forms using **posedge** and **negedge**, they must be followed by a 1-bit expression, typically a clock. A **negedge** is detected on the transition from 1 to 0 (or unknown). A **posedge** is detected on the transition from 0 to 1 (or unknown).

Verilog also provides features to name an event and then to trigger the occurrence of that event. We must first declare the event:

```
event event6;
```

To trigger the event, we use the **->** symbol :

```
-> event6;
```

To control a block of code, we use the **@** symbol as shown:

```
@(event6) begin
    <some procedural code>
end
```

We assume that the event occurs in one thread of control, i.e., concurrently, and the controlled code is in another thread. Several events may to **or**-ed inside the parentheses.

B.1.2.9.3 wait Statement

The **wait** statement allows a procedural statement or a block to be delayed until a condition becomes true.

```
wait (A == 3)
begin
    A = B&C;
end
```

The difference between the behavior of a **wait** statement and an event is that the **wait** statement is **level sensitive** whereas **@(posedge clock)**; is triggered by a **signal transition** or is **edge sensitive**.

B.1.2.9.4 fork and join Statements

By using the **fork** and **join** construct, Verilog allows more than one thread of control inside an **initial** or **always** construct. For example, to have three threads of control, you **fork** the thread into three and merge the three into one with a **join** as shown:

```
fork: three //split thread into three; one for each begin-end
begin
    // code for thread 1
end
begin
    // code for thread 2
end
```

```

begin
    // code for thread 3
end
join // merge the three threads to one

```

Each statement between the **fork** and **join**, in this case, the three begin-end blocks, is executed concurrently. After all the threads complete, the next statement after the **join** is executed.

You must be careful that there is no interference between the different threads. For example, you can't change a register in two different threads during the same clock period.

B.1.2.9.5 Traffic Light Example

To demonstrate tasks as well as events, we will show a hardware model of a traffic light.

```

// Digital model of a traffic light
// By Dan Hyde August 10, 1995
module traffic;
parameter on = 1, off = 0, red_tics = 35,
          amber_tics = 3, green_tics = 20;
reg clock, red, amber, green;

// will stop the simulation after 1000 time units
initial begin: stop_at
    #1000; $stop;
end

// initialize the lights and set up monitoring of registers
initial begin: Init
    red = off; amber = off; green = off;
    $display("                Time green amber red");
    $monitor("%3d    %b    %b    %b", $time, green, amber, red);
end

// task to wait for 'tics' positive edge clocks
// before turning light off
task light;
    output color;
    input [31:0] tics;
    begin
        repeat(tics) // wait to detect tics positive edges on clock
            @(posedge clock);
        color = off;
    end
endtask

```

```
// waveform for clock period of 2 time units
always begin: clock_wave
  #1 clock = 0;
  #1 clock = 1;
end

always begin: main_process
  red = on;
  light(red, red_tics); // call task to wait
  green = on;
  light(green, green_tics);
  amber = on;
  light(amber, amber_tics);
end

endmodule
```

The output of the traffic light simulator is the following:

| Time | green | amber | red |
|------|-------|-------|-----|
| 0 | 0 | 0 | 1 |
| 70 | 1 | 0 | 0 |
| 110 | 0 | 1 | 0 |
| 116 | 0 | 0 | 1 |
| 186 | 1 | 0 | 0 |
| 226 | 0 | 1 | 0 |
| 232 | 0 | 0 | 1 |
| 302 | 1 | 0 | 0 |
| 342 | 0 | 1 | 0 |
| 348 | 0 | 0 | 1 |
| 418 | 1 | 0 | 0 |
| 458 | 0 | 1 | 0 |
| 464 | 0 | 0 | 1 |
| 534 | 1 | 0 | 0 |
| 574 | 0 | 1 | 0 |
| 580 | 0 | 0 | 1 |
| 650 | 1 | 0 | 0 |
| 690 | 0 | 1 | 0 |
| 696 | 0 | 0 | 1 |
| 766 | 1 | 0 | 0 |
| 806 | 0 | 1 | 0 |
| 812 | 0 | 0 | 1 |
| 882 | 1 | 0 | 0 |
| 922 | 0 | 1 | 0 |
| 928 | 0 | 0 | 1 |
| 998 | 1 | 0 | 0 |

Stop at simulation time 1000

B.1.3 System Tasks and Functions

System tasks are not part of the Verilog language but are build-in tasks contained in a library. A few of the more commonly used one are described below. The Verilog Language Reference Manual has many more.

B.1.3.1 \$cleartrace

The `$cleartrace` system task turns off the trace. See “B.1.3.6 \$settrace” on page B.1-25 to set the trace.

```
$cleartrace;
```

B.1.3.2 \$display

Displays text to the screen much like the `printf` statement from the language C. The general form is

```
$display(<parameter>, <parameter>, ... <parameter>);
```

where `<parameter>` may be a quoted string, an expression that returns a value or a null parameter. For example, the following displays a header.

```
$display("Registers:  A  B  C");
```

The special character `%` indicates that the next character is a format specification. For each `%` character that appears in the string, a corresponding expression must be supplied after the string. For example, the following prints the value of A in binary, octal, decimal and hex.

```
$display("A=%b binary %o octal %d decimal %h hex",A,A,A,A);
```

produces the following output

```
A=00001111 binary 017 octal 15 decimal 0f hex
```

The commonly used format specifiers are

```
%b display in binary format
%c display in ASCII character format
%d display in decimal format
%h display in hex format
%o display in octal format
%s display in string format
```

A 0 between the `%` and format specifier allocates the exact number of characters required to display the expression result, instead of the expression's largest possible value (the default). For example, this is useful for displaying the time as shown by the difference between the following two `$display` statements.

```
$display("Time = %d", $time);  
$display("Time = %0d", $time);
```

produces the following output

```
Time =                1  
Time = 1
```

Escape sequences may be included in a string. The commonly used escape sequences are the following:

```
\n the newline character  
\t the tab character  
\ the \ character  
\" the " character  
%% the percent sign
```

A null parameter produces a single space character in the display. A null parameter is characterized by two adjacent commas in the parameter list.

Note that **\$display** automatically adds a newline character to the end of its output. See **\$write** in Verilog Language Reference Manual if you don't want a newline.

B.1.3.3 \$finish

The **\$finish** system task exits the simulator to the host operating system. Don't forget to type the semicolon while in interactive mode.

```
$finish;
```

B.1.3.4 \$monitor

The **\$monitor** system task provides the ability to monitor and display the values of any variable or expression specified as parameters to the task. The parameters are specified in exactly the same manner as the **\$display** system task. When you invoke the **\$monitor** task, the simulator sets up a mechanism whereby each time a variable or an expression in the parameter list changes value, with the exception of **\$time**, the entire parameter list is displayed at the end of the time step as if reported by the **\$display** task. If two or more parameters change values at the same time, however, only one display is produced. For example, the following will display a line anytime one of the registers A, B or C changes.

```
$monitor(" %0d %b %b "%b, $time, A, B, C);
```

Only one **\$monitor** statement may be active at any one time. The monitoring may be turned off and on by the following:

```
$monitoroff;  
<some code>  
$monitoron;
```

B.1.3.5 \$scope

The **\$scope** system task lets the user assign a particular level of hierarchy as the interactive scope for identifying objects. **\$scope** is useful during debugging as the user may change the scope to inspect the values of variables in different modules, tasks and functions.

```
$scope (<name>);
```

The **<name>** parameter must be the complete hierarchical name of a module, task, function or named block. See “B.1.3.7 \$showscopes” on page B.1-25 to display the names.

B.1.3.6 \$settrace

The **\$settrace** system task enables tracing of simulation activity. The trace consists of various information, including the current simulation time, the line number, the file name, module and any results from executing the statement.

```
$settrace;
```

You can turn off the trace using the **\$cleartrace** system task.

B.1.3.7 \$showscopes

The **\$showscopes** system task displays a complete lists of all the modules, tasks, functions and named blocks that are defined at the *current scope level*.

```
$showscopes;
```

B.1.3.8 \$showvars

The **\$showvars** system task produces status information for register and net (wires) variables, both scalar and vector. When invoked without parameters, **\$showvars** displays the status of all variables in the current scope. When invoked with a list of variables, it shows only the status of the specified variables.

```
$showvars;  
$showvars(<list of variables>);
```

B.1.3.9 \$stop

The **\$stop** system task puts the simulator into a halt mode, issues an interactive command prompt and passes control to the user.

```
$stop;
```

B.1.3.10 \$time

The **\$time** system function returns the current simulation time as a 64-bit integer. **\$time** must be used in an expression.

Appendix B.2 Extensions

| | | |
|------------|----------------------------------------------------------|-------|
| B.2.1 | Verilog HDL Extensions | B2-1 |
| B.2.1.1 | SILOS III PLI Interface | B2-1 |
| B.2.1.1.1 | SILOS III PLI Interface on the PC | B2-1 |
| B.2.1.1.2 | SILOS III PLI Interface on the Workstation | B2-2 |
| B.2.1.1.3 | List of Implemented PLI Routines | B2-3 |
| B.2.1.2 | Standard Delay Format | B2-3 |
| B.2.1.3 | Expected Values and Stimulustable | B2-5 |
| B.2.1.3.1 | BNF | B2-5 |
| B.2.1.3.2 | Stimulustable | B2-6 |
| B.2.1.3.3 | Radix | B2-7 |
| B.2.1.3.4 | Delay Time | B2-7 |
| B.2.1.3.5 | Memory Utilization | B2-8 |
| B.2.1.3.6 | Strobe | B2-9 |
| B.2.1.3.7 | I/O Pad | B2-10 |
| B.2.1.3.8 | Expected Value Error | B2-10 |
| B.2.1.3.9 | Expected Value Error Storage | B2-12 |
| B.2.1.3.10 | Incremental Update | B2-12 |
| B.2.1.3.11 | Changing Behavioral Stimulus to a "stimulustable" Format | B2-14 |
| B.2.1.3.12 | Analog Behavioral Modeling (AHDL) | B2-15 |
| B.2.1.3.13 | Specifying the Analog Behavioral Modeling Project | B2-16 |
| B.2.1.3.14 | Running the Analog Behavioral Modeling Simulation | B2-16 |
| B.2.1.4 | Analog Extensions | B2-17 |
| B.2.1.4.1 | Real and Integer Data Types | B2-17 |
| B.2.1.4.2 | Utility Transcendental Functions | B2-17 |
| B.2.1.4.3 | Examples for Transcendental Math Functions | B2-18 |
| B.2.1.5 | "silos" and "sse" keywords | B2-19 |
| B.2.1.6 | Extensions to Turn-off, Reset, and Turn-on Saving | B2-19 |
| B.2.1.7 | SILOS III Extensions to Verilog HDL | B2-19 |
| B.2.1.7.1 | Global Variables | B2-20 |
| B.2.1.7.2 | Global tasks and functions | B2-20 |
| B.2.1.7.3 | Functions with multiple outputs | B2-20 |

| | | |
|------------|------------------------------------------------------------------------------------------------------|-------|
| B.2.1.7.4 | Functions without any inputs: | B2-20 |
| B.2.1.7.5 | Tasks and functions with ports declared like a module: | B2-21 |
| B.2.1.7.6 | Procedural assignment to wires: | B2-21 |
| B.2.1.7.7 | Continuous assignments to register and memory variables: | B2-21 |
| B.2.1.7.8 | Continuous assignments using intra-assignment/non-blocking delays: | B2-21 |
| B.2.1.7.9 | Default state value for UDP: | B2-22 |
| B.2.1.7.10 | UDP additional states for High-Z on inputs or output: | B2-22 |
| B.2.1.7.11 | UDP edge for High-Z: | B2-22 |
| B.2.1.7.12 | UDP Multiple Edges in a Row: | B2-23 |
| B.2.1.7.13 | Non-Constant Specify Block Delays: | B2-23 |
| B.2.1.7.14 | Parameter for Specify Block Delays: | B2-23 |
| B.2.1.7.15 | Stimulustable Extension: | B2-23 |
| B.2.1.7.16 | "input/output/inout" declarations after the variable's declaration: | B2-24 |
| B.2.1.7.17 | Using registers as module inputs: | B2-24 |
| B.2.1.7.18 | Duplicate variable definitions: | B2-24 |
| B.2.1.7.19 | Parameter used for sizing numbers: | B2-24 |
| B.2.1.7.20 | Null statements: | B2-25 |
| B.2.1.7.21 | Timing checks without edge specifications for selected variables: | B2-25 |
| B.2.1.7.22 | More precision in "\$timeformat" than "timescale": | B2-25 |
| B.2.1.7.23 | Missing port connections are set to ground for VCS compatibility: | B2-25 |
| B.2.1.7.24 | VCS compatibility extension for comma at the end of the port list, i.e.: module (xx(a): | B2-25 |
| B.2.2 | Silos III Command Line Usage | B2-26 |
| B.2.2.1 | Commands Overview | B2-26 |
| B.2.2.1.1 | Command Syntax | B2-26 |
| B.2.2.1.2 | Inputting SILOS Commands | B2-26 |
| B.2.2.1.3 | Stopping Processes | B2-26 |
| B.2.2.2 | Activity Report For Nodes | B2-26 |
| B.2.2.3 | Bus Contention Report | B2-28 |
| B.2.2.4 | Encrypting Library Files | B2-29 |
| B.2.2.5 | Control Parameters For Logic Simulation | B2-30 |
| B.2.2.6 | Default Device Delay Times | B2-34 |

| | | |
|------------|----------------------------------------------------|-------|
| B.2.2.7 | Disk File Name Reassignment | B2-35 |
| B.2.2.8 | Error Summary | B2-36 |
| B.2.2.9 | Exclude Saving Simulation Node States | B2-36 |
| B.2.2.10 | Exiting The Program | B2-37 |
| B.2.2.11 | File Name Specification | B2-38 |
| B.2.2.12 | Keeping Simulation Node States | B2-39 |
| B.2.2.13 | Exclude Saving Module Instance Variable Values | B2-40 |
| B.2.2.14 | Keeping Module Instance Simulation Variable Values | B2-41 |
| B.2.2.15 | Nonconvergence Summary | B2-42 |
| B.2.2.16 | Narrow Storing Outputs | B2-43 |
| B.2.2.17 | Preprocessing Data | B2-44 |
| B.2.2.18 | Probing Node States | B2-45 |
| B.2.2.19 | Quitting Execution | B2-46 |
| B.2.2.20 | Resetting Selected Data | B2-47 |
| B.2.2.21 | Scope For Printing Module Variables | B2-48 |
| B.2.2.22 | Logic Simulation Specification | B2-48 |
| B.2.2.23 | Size-Of-Data Reprint | B2-49 |
| B.2.2.24 | Spike Summary Output | B2-50 |
| B.2.2.25 | Storing Outputs | B2-51 |
| B.2.2.26 | Strength Specification For Gates | B2-52 |
| B.2.2.27 | Symbol Modification For Output | B2-53 |
| B.2.2.28 | Batch Execution Overview | B2-55 |
| B.2.2.28.1 | Commands in Files | B2-55 |
| B.2.2.28.2 | Command-line Options | B2-56 |
| B.2.2.28.3 | Windows Batch Execution | B2-60 |
| B.2.2.28.4 | Unix Batch Execution | B2-61 |
| B.2.3 | Verilog Libraries | B2-63 |
| B.2.3.1 | Overview | B2-63 |
| B.2.3.2 | Library Command | B2-63 |
| B.2.3.3 | TTL LS Parts List | B2-64 |
| B.2.3.4 | TTL BCT Parts List | B2-73 |

Appendix B.2 Extensions

B.2.1 Verilog HDL Extensions

B.2.1.1 SILOS III PLI Interface

SILOS III dynamically interfaces the user written or vendor supplied Programming Language Interface (PLI) routines with the SILOS III executable at runtime. Interfacing the PLI routines at run time has the following advantages:

- The user does not have to create a new SILOS III executable or have a different executable for each set of vendor supplied PLI routines.
- Dynamically linking the PLI routines at runtime is faster than having to recompile and create a new executable each time.
- Upgrading to new versions of SILOS III is simple because there is no need to recompile and create a new executable.

B.2.1.1.1 SILOS III PLI Interface on the PC

The PLI can be used with SILOS III on Windows NT version 4.0 and greater, and on Windows 95 and Windows 98. Contact Simucad for an updated list of supported platforms. You may also need a "C" compiler, such as the MS Visual C++ compiler, to compile any user written PLI routines and to create a ".dll" file to link with SILOS III. To use PLI on the PC platform:

- Create one or more ".dll" files that contain the object code for the PLI. The object code must have been compiled for the type of platform you are using. For example, object code from the Sun will not work on the PC.
- The SILOS III "pliload" command is used to specify the ".dll" files for SILOS III at runtime. The "pliload" command is cumulative so that one or more "pliload" commands is allowed before starting simulation. The "pliload" command can be entered in the Com-

Extensions

mand window for the Main toolbar, from the SILOS III command line, or from a file.

| | |
|----------------------------------------------------------------------------|--------------------------------------------------------------------------------------|
| pliloadmypli.dll | Example for entering the pliload command in the Command window for the Main toolbar. |
| silos.exe myfile.v- !pliloadmypli.dll | Example for entering the pliload command at the command line. |
| <pre> module foo; ... endmodule `ifdef silos !pliload `endif </pre> | Entering the pliload command from a file. |

- For more information, see the "README.TXT" file in the PLI subdirectory for the SILOS III installation.
- For an example of using PLI with SILOS III, see file "pli01.spj" in the PLI subdirectory for the SILOS III installation, or contact Simucad.

B.2.1.1.2SILOS III PLI Interface on the Workstation

The PLI can be used with SILOS III on the Sun and HP workstations supported by SILOS III. Contact Simucad for an updated list of supported platforms. To use PLI on the workstation:

- Create one or more ".so" files that contain the object code for the PLI. For example, to create a ".so" file on Solaris, enter the following load command.

```
ld -o mylib.so -dy -G *.o
```

- The SILOS III "pliload" command is used to specify the ".so" files for SILOS III at runtime. The "pliload" command is cumulative so that one or more "pliload" commands is allowed before starting simulation. The "pliload" command can be entered at the in the Command window for the Main toolbar, from the SILOS III command line, or from a file.

| | |
|----------------------------------------|--------------------------------------------------------------------------------------------|
| pliload mypli.so | example of entering the pliload command at the in the Command window for the Main toolbar. |
| silos.exe myfile.v -"!pliload mypli.so | "example of entering the pliload command at the command line. |

`pliload mypli.so` example of entering the `pliload` command at the
in the Command window for the Main toolbar.

```
module foo;
...
endmodule
`ifdef silos
!pliload mypli.so
`endif
```

entering the `pliload` command from a file.

- For more information, see the "README.TXT" file in the PLI subdirectory for the SILOS III installation.
- For an example of using PLI with SILOS III, see file "pli01.spj" PLI subdirectory for the SILOS III installation, or contact Simucad.

B.2.1.1.3 List of Implemented PLI Routines

The Silos Simulation Environment uses the IEEE 1364 "Standard Hardware Description Language Based on the Verilog Hardware Description Language" manual as the specification for the PLI. Many of the "tf_" PLI routines for linking user "C" programs to SILOS III have been implemented. The user "C" programs could be used for modeling a circuit or for creating test vectors. Selected "acc_" PLI routines have also been implemented. Contact Simucad for the list of implemented PLI routines.

B.2.1.2 Standard Delay Format

SILOS III supports the Standard Delay File (SDF) format. SDF is a text file that contains the instance names and delay values necessary to back-annotate delays into a Verilog HDL description. SDF is usually generated by another tool such as a place and route tool.

The `$sdf_annotate` system task is used to specify the SDF file (do not input the SDF file). The format specification for the `$sdf_annotate` system task is:

```
$sdf_annotate("file_name", module_instance);
```

where:

`file_name` represents any valid file path and file name specification.

Extensions

`module_instance` represents the name of the module instance. The hierarchy of this instance is used for back annotation. The names in the SDF file are relative paths to the `module_instance` or full paths with respect to the entire Verilog HDL description. For example, if you use the `module_instance` name "top.dff1" then the instance names in the SDF file are relative to "top.dff1". If you omit `module_instance`, SILOS III uses the module containing the call to the `$sdf_annotate` system task as the `module_instance` for annotation.

For examples on using SDF, see the example on the next page, and see project `fltsim.spj` (fault simulation example) in the `examples` subdirectory for the installation.

For the below example and diagram, if the SDF file contained the following instance name:

```
(INSTANCE name2.name4)
  (DELAY
    (ABSOLUTE
      (IOPATH IN0 OUT (2420:2420:2420) (2420:2420:2420))
```

then the `$sdf_annotate` system task to specify the SDF file and its relative position in the design's hierarchy would be:

```
module testbench;
  initial $sdf_annotate("filename.sdf", testbench.name1);
```

When SILOS III reads file "filename.sdf" to update the design, the path "testbench.name1" is concatenated with path "name2.name4" to form path "testbench.name1.name2.name4". Signals "IN0" and "OUT" are then updated as specified in the above example.

Diagram of the Design Hierarchy for the SDF Example

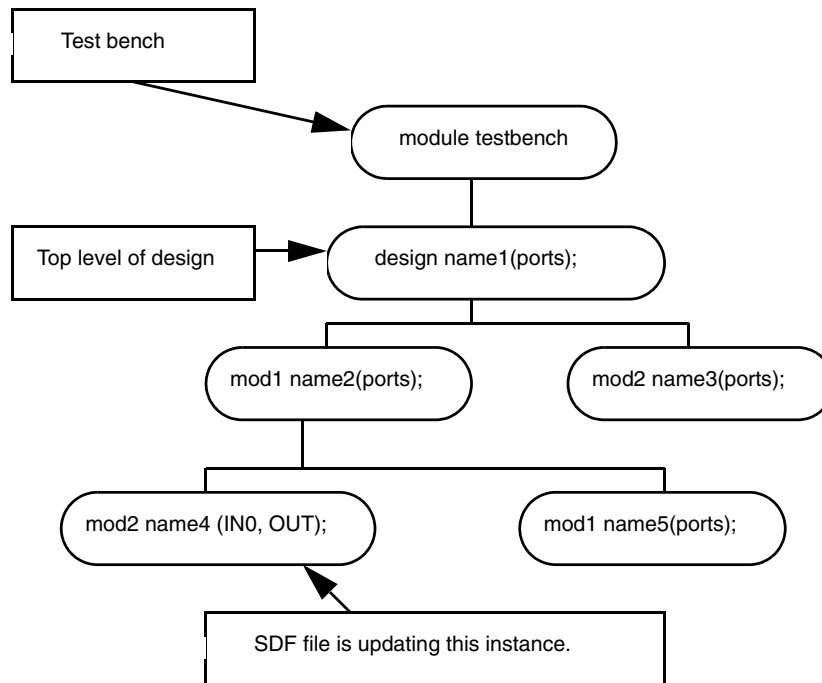

B.2.1.3 Expected Values and Stimulustable

The IEEE Verilog specification does not describe any syntax for tabular representation of input data, nor expected value information. The stimulustable statement is a SILOS III enhancement which provides tabular format for input data. The stimulustable statement also can combine expected value information with the tabular format for input data.

B.2.1.3.1BNF

```
stimulustable <id> ;
    table [# delay-expression]? <probe> <,><probe>>* ;
    <delay-constant>? <data>+ ;
    <delay-constant>? <data>+ ;
    .....
```

```

    endtable
endstimulustable
probe      ::= <data-format>? <variable> <(variable)?@ <strobe>?
    if <data-format> is omitted then %h is assumed.

data-format ::= %h
             || = %o
             || = %b

```

For replacing an existing stimulus table after prep:

```

stimulustable <id> ;
    table <# delay-expression>? ;
    <delay-constant>? <data>+ ;
    <delay-constant>? <data>+ ;
    .....
endtable
endstimulustable

```

B.2.1.3.2 Stimulustable

"stimulustable" is a behavioral statement and can be located anywhere any statement can be placed, e.g.

```

for (i=1; i<=8; i = i+1) // repeat 8 times the input pattern
    stimulustable
    ...
endstimulustable

```

There is no limit to the number of stimulustable statements. They are not required to be located in top-level modules. The syntax for the stimulustable keywords must be lower case. Such as, the keyword "table" must be lower case. Variable names are upper/lower case sensitive.

Any number of input or expected value columns may appear in a stimulustable. Each input column is identified by a variable which is driven by the data in the column. Each expected value column is identified by an @ sign. The variable on the left side of an @ sign is verified against the data in the column. The variable on the right side of the @ sign is used as a strobe. Variables used in the table can be a wire, register, memory element, integer or real variable of any width and they can have any valid Verilog name.

In the example below for stimulustable s1, register variable in1 and memory element in2 are driven by the data in the table. Wire out1 is verified against the data in the table whenever the variable strobe1 is high. To prevent possible race conditions, the rising or the falling edge of the strobe signal "strobe1" should not coincide with a change in the expected output for "out1" in the stimulustable.

```

!control .ext=stim
`timescale 1ns/100ps
module test;
reg [7:0] in1, in2[1:0];
wire[7:0] out1 = ~in1 | in2[0];
reg strobe1;
initial strobe1 = 0;
always @out1 begin #0.1 strobe1 = 1; #0.1 strobe1 = 0; end
initial
begin
#5;
stimulustable s1;
table #1.2 in1, in2[0], out1@strobe1;
                00  00 ff;
                0e  0a f6;
                ff  ff 00;
endtable
endstimulustable
end
endmodule

```

B.2.1.3.3 Radix

Data in the table can be in hexadecimal (*%h* is the default), octal (*%o*), or binary (*%b*) for register data-types, and integer or floating point for integer and real data types. There must be one or more blank spaces between the radix symbol and the variable name it refers to, such as *%h in2*. Each row of values in the table is terminated by a semicolon ";". Blank spaces and tabs (not carriage returns) can be used to delineate the values between different variables, however, white space is not allowed between the values for a vector variable. An example for specifying the radix is shown below:

```

table #1.2%b in1,in2,out@strobe;
00000000 00 ff
00001110 0a f6;
11111111 ff 00;

```

For single bit wires, SILOS state symbols may be used to enter states other than 1, 0, x, z. See “B.2.2.27 Symbol Modification For Output”.

B.2.1.3.4 Delay Time

The delay time for a constant increment of time (delta time) between application of subsequent table lines can be specified as a single expression:

```

table #delta .... ;

```

When the delta delay is specified on the table header, then the first table line is applied immediately upon execution of the `stimulustable` statement.

The delay time can also be specified on each table line. When no `#` sign is specified on the table header, then the delay values are added to the simulation time as the `stimulustable` is read. The delay is applied prior to the application of the table line. The time units for the delay value can be specified by preceding the module containing the `stimulustable` statement with a ``timescale` statement. Below is an example:

```
`timescale 1ns / 1ns
#10 // time=10
table in1,in2,out@strobe;
1.2 00 00 ff; // time=11.2
1.6 0e 0a f6; // time=12.8
2.1 ff ff 00; // time=14.9
```

If two `##` signs are specified on the table header, then the delay values are relative to the time the stimulus table is started (very much like delay values in a `fork/join` statement). For example:

```
#10 // time=10
table ## in1,in2, out@strobe;
1.2 00 00 ff; // time=11.2
1.6 0e 0a f6; // time=11.6
2.1 ff ff 00; // time=12.1
```

To have each delay value represent absolute time, start the `stimulustable` at `time=0`. For example:

```
initial begin
    stimulustable s1;
table ## in1,in2, out@strobe;
1.2 00 00 ff; // time=1.2
1.6 0e 0a f6; // time=1.6
2.1 ff ff 00; // time=2.1
```

Note that mixing of both delay styles in the same stimulus is not allowed.

B.2.1.3.5 Memory Utilization

Data specified in tables is not stored in RAM, so as to reduce memory used when there is a large pattern.

B.2.1.3.6 Strobe

Expected value information is conditioned by a strobe. When the strobe is high, the variable must agree with the data in the column as follows:

```
1 <==> 1
0 <==> 0
x <==> don't care
z <==> High impedance strength (0,1, or x)
```

The expected value check is engaged when the `stimulustable` statement begins execution, and persists through one strobe cycle following the conclusion of the `stimulustable` statement. During engagement of the expected value check, a high (positive) strobe is required to check that the variable agrees with the expected value data. To prevent possible race conditions, the rising or the falling edge of the strobe signal should not coincide with a change in the expected output signal in the `stimulustable`.

For example, in `stimulustable s1` (shown below) variable `strobe1` strobes `out1` every 0.2 nano seconds. This is faster than the input values change (every 1.2 nano seconds) for variables `in1` and `in2`. When the second entry in the table is executed the calculated value for `out1` (`f6`) does not equal its expected value. The violation is recorded at the next high pulse for variable `strobe1` and then is not recorded again until after the next entry in the table occurs.

```
!control .ext=stim
`timescale 1ns/100ps
module test;
  reg [7:0] in1, in2[1:0];
  wire[7:0] out1 = ~in1 | in2[0];
  reg strobe1;
  initial strobe1 = 0;
  always @out1 begin #0.1 strobe1 = 1; #0.1 strobe1 = 0; end
  initial
  begin
    #5;
    stimulustable s1;
      table #1.2 in1, in2[0], out1@strobe1;
        00 00 ff;
        0e 0a f6;
        ff ff 00;
      endtable
    endstimulustable
  end
endmodule
```

Using the `disable` statement to disable the block containing the `stimulustable` statement immediately terminates expected value checking.

Each expected value column has one strobe, however multiple columns may each have different strobes.

B.2.1.3.7 I/O Pad

The `stimulustable` can be used to model a bi-directional I/O pad. In the example below for `stimulustable s1`, variable `enable` controls the bi-directional I/O pin `bi_pad`. When `enable` is high (1), pin `bi_pad` acts as an output pin and expected value checking is performed every time `strobe1` goes high. The `stimulustable` also ignores any values in the table for pin "bi_pad" when "enable" is high. When `enable` is low (0), pin `bi_pad` acts as an input pin and the `stimulustable` applies the values in the table for pin `bi_pad` as input stimulus. Expected value checking is ignored for pin `bi_pad` when `enable` is low.

```
!control .ext=stim
`timescale 1ns/100ps
module test;
    wire chipside, bi_pad, enable, out;
    buf(chipside, bi_pad); // buf(out, in);
    bufif1(bi_pad, chipside, enable); // bufif1(out, in, enable);
    buf(out, chipside);
    reg strobe1;
    initial strobe1 = 0;
    always @bi_pad begin #8 strobe1 = 1; #1 strobe1 = 0; #1; end
    initial
        begin
            #5;
            stimulustable s1;
            table #10 chipside, enable, out@strobe1,
bi_pad(enable)@strobe1;
                1 1      1 1; // output cycle
                0 1      0 0; // output cycle
                1 0      1 1; // input cycle
                0 0      0 0; // input cycle
            endtable
            endstimulustable
        end
    endmodule
```

B.2.1.3.8 Expected Value Error

Expected value errors trigger a global register named `ExpectedValueError`. This register is simultaneously set with specific information about the expected value violated.

- The `ExpectedValueError` variable can be accessed either:

from the data file to cause immediate interaction with the simulation, e.g.

```
always @ExpectedValueError $stop;
```

from the \$monitor system task or the SILOS III probe command the variable prints a terse string indicating the stimulus name and column name violated, e.g.

```
$monitor($time,,ExpectedValueError);
```

To obtain all violations at a single time-point:

```
probe iter ExpectedValueError
```

To obtain time points for which there is at least one violation:

```
probe ExpectedValueError
```

Note other variables may simultaneously be probed, e.g.

```
probe out,,ExpectedValueError
```

When the ExpectedValueError signal is displayed in the Data Analyzer, value for the ExpectedValueError signal is "none" when there is no violation, and "x" when there is a violation. The "Scan T1 Right" and the "Scan T1 Left" buttons on the Analyzer Toolbar can be used to scan to expected value violations. If the ExpectedValueError signal shows a series of contiguous "none" values, then the rising and falling edge of the strobe signal may be coincident with the changes for the expected value signal in the stimulustable. For example, the rising and falling edge of the strobe signal "strobe1" does not coincide with expected output signal "out1" in the next example.

The below example shows how to use the ExpectedValueError variable with \$monitor:

```
!con .ext=stim
//title example with $monitor
`timescale 1ns/100ps
module test;
  reg [7:0] in1, in2[1:0];
  wire[7:0] out1 = ~in1 | in2[0];
  reg strobe1;
  initial strobe1 = 0;
  always @out1 begin #0.1 strobe1 = 1; #0.1 strobe1 = 0; end
  initial
    begin
```

```

$timeformat(-9,3,"ns",-15);
$monitor("%t",$realtime,, ExpectedValueError);
#5;
stimulustable s1;
    table #1.2 in1, in2[0],out1@strobe1;
        00      00  ff;
        0e      0a  f6;
        ff      ff  00;
    endtable
endstimulustable
#10 $finish;
end
endmodule

```

The output from the \$monitor is shown below:

```

6.300ns :s1 out1 fb != f6:
6.400ns
7.500ns :s1 out1 ff != 00:
7.600ns

```

For the first line:

```

6.300ns :s1 out1 fb != f6:

```

The "6.300ns" is the time the difference occurred, the "s1" is the instance name for the stimulustable, the "fb" is the simulation value for variable "out1", and the "f6" is the expected value for "out1".

B.2.1.3.9 Expected Value Error Storage

The expected values are stored in variables that use the root name of the variable whose value is checked with an <expected><number> appended to the name. These variables can be accessed with the probe or print commands, or viewed in the Data Analyzer.

B.2.1.3.10 Incremental Update

"stimulustable" data can be incrementally replaced without having to re-input all the files in the design. This allows quick iteration of different stimulus/expected-value patterns. The incremental stimulustables can be specified at any time after preprocessing (the "!prep" command). When specifying the incremental stimulustables, each incremental stimulustable must be specified outside of any module, and the variable names can not be put on the table line. The name of the stimulustable is used to determine which stimulustable is updated.

The file below, "test.v", shows the top level module with a stimulustable that is simulated until the "\$finish" is encountered:

```

File "test.v":
!con .ext=stim
`timescale 1ns/100ps
module main;
  reg [8:0]  r9;
  reg       r1;
  initial
  begin
    stimulustable s1;
      table #10 %b r9,      r1;
          000000000  1;
          000010000  0;
          111111111  x;
          100000001  0;
      endtable
    endstimulustable
    #10 $finish;
  end
endmodule
!sim
`include "test1.v"

```

The next file, "test1.v" shows the new stimulustable values. To simulate the new values, use ``include` to input file "test1.v". Notice that the delta delay value was changed from "#10" for the first version of stimulustable "s1" to "#20" for the second version of stimulustable "s1". The command `!sim 0 2100m` will restart the simulation at time=0 and simulate until the "\$finish" in file test.v:

```

File "test1.v":
  stimulustable s1;
    table #20;
        001100000  0;
        011010000  x;
        111111111  x;
        100010001  1;
    endtable
  endstimulustable
!sim 0 2100m

```

B.2.1.3.11 Changing Behavioral Stimulus to a "stimulustable" Format

Using a stimulustable statement instead of behavioral stimulus has the following advantage:

- The stimulustable is input in chunks so it requires less memory.

To change behavioral stimulus to a stimulustable format, you can simulate the behavioral stimulus with SILOS III and then store the results from the "probe" command as a file of tabular ones and zeros. The file can then be edited to remove the title for the "probe" command report. Each line of tabular values in the file must end with a semicolon ";". To add a semicolon at the end of each line, put a ";" at the end of the probe state, i.e.:

```
!store probe in1,,in2,,bi1_,,bi2_,";"
```

For example, for file "stimulus.v":

```
`timescale 1ns / 100ps
module foo;
  reg in1, in2;
  reg bi1_, bi2_;
  wire bi1 = bi1_; // bi-directional inputs
  wire bi2 = bi2_; // bi-directional inputs
  initial
  begin
    in1=0; in2=0;
    bi1_=0; bi2_=0;
    #10 in1=1; bi1_=1;
    #10 bi2_=1'bz;
    #10 $finish;
  end
endmodule
```

The following commands would be used from a file to simulate the stimulus:

```
`include "stimulus.v"
!control .savsim=2
!sim
!disk stim.v
!scope foo
!store probe in1,,in2,,bi1_,,bi2_,";"
```

Next, edit file "stim.v" and remove the report header for the probe report and any messages from the probe report.

Then, include file "stim.v" into a stimulustable statement:

```
!control .ext=stim
`timescale 1ns / 100ps
module foo;
```

```

reg in1, in2;
reg bi1_, bi2_;
wire bi1 = bi1_; // bi-directional inputs
wire bi2 = bi2_; // bi-directional inputs
initial
begin
  `timescale 100ps / 100ps // timescale for stimulustable
  stimulustable s1;
    table ## in1, in2, bi1_, bi2_;
      `include "stim.v"
    endtable
  endstimulustable
  `timescale 1ns / 100ps // respecify the circuit's timescale
  #10 $finish;
end
endmodule

```

When converting behavioral stimulus to tabular stimulus, you need to ensure that timescale for the tabular stimulus is correct. The units for the time values from the "probe" command are equal to the smallest resolution for the simulation. This may require a `timescale compiler directive before the stimulustable statement so that the delay values are scaled correctly. In the above example, the resolution of the ``timescale 1ns/100ps" compiler directive for the circuit is "100ps", so a "timescale 100ps/100ps" compiler directive must be used before the stimulustable statement.

Notice that the stimulustable for the above example also uses the "##" delay notation, so that the time values are relative to the time that the stimulustable statement is started.

Notice also that you may need to be careful when applying the stimulus for "inout" (bi-directional) pins in the circuit. The "inout" pins "bi1" and "bi2" are defined as the left hand side of continuous assignments. For this circuit, the stimulustable values should be applied to the registers "bi1_" and "bi2_". Otherwise, registers "bi1_" and "bi2_" will remain at an Unknown level and will continue to drive wires "bi1" and "bi2" to an Unknown level due to the continuous assignments.

B.2.1.3.12 Analog Behavioral Modeling (AHDL)

This example demonstrates analog behavioral modeling using the SILOS Simulation Environment (SSE) (for more information, see "B.2.1.4 Analog Extensions").

Skills presented in this section are:

- Setting up a project for analog simulation.
- Using analog behavioral modeling in a gate level simulation.
- Viewing analog and digital waveforms in the Data Analyzer Window.
- The file used for this example is listed below:

analog.v: Shows a simple example of an A/D converter modeled with analog behavioral modeling and gate level logic.

B.2.1.3.13 Specifying the Analog Behavioral Modeling Project

For this example, file "analog.v" shows an A/D converter with comments. For additional information, see "B.2.1.4 Analog Extensions". The essential ideas for analog behavioral modeling are:

- Ψ SILOS III has the ability to pass real variables and integer variables in module ports. There is no need to convert reals or integers to bit vectors. This is an extension to the IEEE standard for Verilog HDL. If you need the real or integer variables to behave as wires you can use the "wire real" or "wire integer" declaration. (For more information, see "B.2.1.4.1 Real and Integer Data Types")
- Ψ SILOS III supports analog extensions that allow you to put most of the standard math functions, such as "sine", "cosine", "log", "power", directly in your Verilog HDL code. This is an extension to the IEEE standard for Verilog HDL ("B.2.1.4.2 Utility Transcendental Functions").

The project for analog behavioral modeling is already set up. To open the project, select the "Project/Open" menu selection. Then change to the "examples" subdirectory of the installation directory, select project "analog.spj" and then click-on the "OK" button to close the dialog box.

B.2.1.3.14 Running the Analog Behavioral Modeling Simulation

Click-on the "Go" button on the Toolbar to load the input file and run logic simulation. The logic simulation will run until it encounters the \$finish system task in file "analog.v".

To display the logic simulation results, click-on the "Open Analyzer" button on the Toolbar to open the Analyzer Window. You should see both analog and digital waveforms displayed in the Waveform Display Window.

You can double-click on the analog signal names "top:feedback" and "top:analog_in" to toggle between a piece-wise linear or analog display (see "B.3.10.6.1 Digital and Analog Signal Display"). The integer "top:counter_value" can also be displayed as an analog waveform by selecting the "Options/Analog Integer Display" menu selection. You can use the timing markers to display the analog values.

This concludes the analog behavioral modeling example. To run the other examples for the Tutorial, see "Design, Simulation and Debug with Multisim's Verilog HDL".

B.2.1.4 Analog Extensions

Simucad has added extensions to the Verilog Hardware Description Language (HDL) that allow SILOS III to model analog circuits at the behavioral level.

B.2.1.4.1 Real and Integer Data Types

SILOS III supports real and integer data types as defined by the IEEE P1364 Standard Verilog HDL Language Reference Manual. To facilitate analog behavioral modeling, SILOS III also supports the following unique extension to the Verilog language:

- Real (floating point) and integer variables can be passed between module ports.

The advantages of directly passing real and integer variables between modules are:

- ease of programming style;
- no loss of information (as occurs with other Verilog simulators).

Passing numerical values between behavioral modules is particularly useful when modeling analog behavior for circuits such as analog to digital converters, phase lock loops, charge pumps, etc. For an example of an analog to digital converter, see file "analog.v" in the "examples" subdirectory of the installation directory.

B.2.1.4.2 Utility Transcendental Functions

To simplify the implementation of analog models, SILOS III supports a full range of transcendental math functions. The following functions accept a single floating-point argument x and return a floating-point value (except for pow , which has two floating point arguments x and y):

| Function Name | Description |
|------------------|-------------------|
| $\sin(x)$ | sine |
| $\cos(x)$ | cosine |
| \tan | tangent |
| $\text{asin}(x)$ | inverse sine |
| $\text{acos}(x)$ | inverse cosine |
| $\text{atan}(x)$ | inverse tangent |
| $\sinh(x)$ | hyperbolic sine |
| $\cosh(x)$ | hyperbolic cosine |

| Function Name | Description |
|---------------|--------------------|
| tanh(x) | hyperbolic tangent |
| sqrt(x) | square root |
| exp(x) | exponential |
| log10(x) | common logarithm |
| log(x) | natural logarithm |
| pow(x,y) | power xy |

B.2.1.4.3 Examples for Transcendental Math Functions

The transcendental functions are used in the same way as any other Verilog function. The module below illustrates a simple use of displaying values for the math functions:

```

module math03;
  initial
  begin
    real pi;
    pi = 3.14159;
    $display ( "sin(0.0) = 0:",  sin(0.0));
    $display ( "sin(0.5 * pi - 0.01) = 0.99995:",  sin(0.5 * pi -
0.01));
    $display ( "cos(0.00234) = 0.999997:",  cos(0.00234));
  end
endmodule

```

The next example shows how to generate a sine wave using the "sin" function:

```

//title example for generating a sine wave
// The example below generates a sine wave "y" based on the value of
"x".
module sine_wave;
  real x, y;
  initial
  begin
    x = 0;
    #1000 $finish;
  end
  always
  begin
    #1 x = x + 0.1;

```

```

        y = sin(x); // Built-in SILOS III "sin" function
    end
endmodule

```

B.2.1.5 "silos" and "sse" keywords

SILOS III has a reserved keyword "silos" that is always true. The "silos" keyword allows the user to enclose Silos specific code or commands within a ``ifdef`/`else`/`endif` compiler directive so that it will be available for SILOS III but not other Verilog simulators, e.g.:`

```

`ifdef silos
    initial $stopsave();
    initial #1000000 $resetstartsave();
`endif

```

When running the SSE, the reserved keyword "sse" is always true so that the user can enclose code or commands that is specific to the GUI within a ``ifdef`/`else`/`endif` compiler directive.`

B.2.1.6 Extensions to Turn-off, Reset, and Turn-on Saving

When running a simulation that creates a large save file, the \$stopsave system task can be used to turn off saving to the save file. This can be used to keep the save file size fixed during the portion of the simulation that is of no interest for the designer.

The \$resetstartsave system task can be used to reset the save file and then start saving the simulation history. After the simulation is complete, the simulation history that has been saved after resetting the save file will be available for display with the Data Analyzer.

The below example stops saving at time=0, and starts saving at time=1000000:

```

`ifdef silos
    initial $stopsave();
    initial #1000000 $resetstartsave();
`endif

```

B.2.1.7 SILOS III Extensions to Verilog HDL

SILOS III has a switch to issue syntax errors for extensions to the IEEE P1364 Standard Verilog HDL Language Reference Manual. The default setting for the switch is to check for IEEE compliance. To allow all extensions, enter `"!control .ext=all"` before inputting your model. The parameters to allow individual extensions are reported in the syntax error for each

extension. The following sections include a sample list of extensions that will be flagged as syntax errors:

B.2.1.7.1 Global Variables:

example:

```
wire xx;
module ... endmodule
SILOS III command to allow this extension:
!control .ext=gvar
```

B.2.1.7.2 Global tasks and functions:

example:

```
function
...
endfunction
module
...
endmodule
SILOS III command to allow this extension:
!control .ext=gft
```

B.2.1.7.3 Functions with multiple outputs:

example:

```
function xx(in, out2);
input in;
output out2;
SILOS III command to allow this extension:
!control .ext=fmout
```

B.2.1.7.4 Functions without any inputs:

example:

```
x = funct();
SILOS III command to allow this extension:
```

```
!control .ext=fzero
```

(For more information, see section 9.3.4 of the Verilog HDL Reference on-line help file)

B.2.1.7.5 Tasks and functions with ports declared like a module:

example:

```
task foo(in1,in2);
```

SILOS III command to allow this extension:

```
!control .ext=formals
```

B.2.1.7.6 Procedural assignment to wires:

example:

```
module foo;
```

```
  wire w;
```

```
  initial w = 1;
```

SILOS III command to allow this extension:

```
!control .ext=paw
```

4.7.7

B.2.1.7.7 Continuous assignments to register and memory variables:

example:

```
reg r;
```

```
assign r = in;
```

SILOS III command to allow this extension:

```
!control .ext=aar
```

(For more information, see sections 5.1 and 11.1 of the Verilog HDL Reference on-line help file)

B.2.1.7.8 Continuous assignments using intra-assignment/non-blocking delays:

example:

```
module foo;
```

```
  wire o, o1;
```

```
  assign o = #4 i;
```

```

    assign o1 <= #4 i;
    SILOS III command to allow this extension:
    !control .ext=assign

```

(For more information, see section 5.1 of the Verilog HDL Reference on-line help file)

B.2.1.7.9 Default state value for UDP:

The "default" keyword for the UDP specifies the state value for the UDP's output when UDP input levels and transitions do not match any of the entries in the UDP table. When the "default" keyword is not used, the UDP default output state is "x".

example:

```

primitive udp1 (out, in);
    output out;
    input in;
    table
    // in  out
    0   :  1;
    default:  0;
    endtable
endprimitive

```

SILOS III command to allow this extension:

```
!control .ext=udpdefault
```

(For more information, see section 7.1 of the Verilog HDL Reference on-line help file)

B.2.1.7.10 UDP additional states for High-Z on inputs or output:

example:

```

    for row states other than "0,x,1", such as:
    Z : 1;
    <?HV> : 1;

```

SILOS III command to allow this extension:

```
!control .ext=udpstate
```

(For more information, see section 7.1 of the Verilog HDL Reference on-line help file)

B.2.1.7.11 UDP edge for High-Z:

example:

```

    for edges to High-Z, such as
    (0Z) : 1;

```

SILOS III command to allow this extension:

```
!control .ext=udpstate
```

(For more information, see section 7.1 of the Verilog HDL Reference on-line help file)

B.2.1.7.12UDP Multiple Edges in a Row:

example:

```
(01) (01): 1;
```

SILOS III command to allow this extension:

```
!control .ext=udpstate
```

(For more information, see section 7.5 of the Verilog HDL Reference on-line help file)

B.2.1.7.13Non-Constant Specify Block Delays:

example:

```
for non-constant specify block delay, such as
(in => out) = delay_var;
```

SILOS III command to allow this extension:

```
!control .ext=ncsd
```

(For more information, see section 13.1 of the Verilog HDL Reference on-line help file)

B.2.1.7.14Parameter for Specify Block Delays:

example:

```
for parameter used for specify block delay, such as
parameter dly=8
(in => out) = dly;
```

SILOS III command to allow this extension:

```
!control .ext=psd
```

(For more information, see section 13.1 of the Verilog HDL Reference on-line help file)

B.2.1.7.15Stimulustable Extension:

example:

```
for using the stimulustable statement, such as
stimulustable ... endstimulustable statement
```

SILOS III command to allow this extension:

```
!control .ext=stim
```

B.2.1.7.16 "input/output/inout" declarations after the variable's declaration:

example:

```
module foo (in);  
  wire in;  
  input in;  
SILOS III command to allow this extension:  
  !control .ext=inout
```

(For more information, see section 12.1 of the Verilog HDL Reference on-line help file)

B.2.1.7.17 Using registers as module inputs:

example:

```
module xx(in);  
  input in;  
  reg in;"  
SILOS III command to allow this extension:  
  !control .ext=rsink
```

(For more information, see section 12.4.6 of the Verilog HDL Reference on-line help file)

B.2.1.7.18 Duplicate variable definitions:

example:

```
module foo;  
  wire a;  
  wire a;  
SILOS III command to allow this extension:  
  !control .ext=dvd
```

(For more information, see section 3.1 of the Verilog HDL Reference on-line help file)

B.2.1.7.19 Parameter used for sizing numbers:

example:

```
module foo;  
  reg[7:0] xx;  
  parameter size=8;  
  initial  
    xx = size'b010;  
SILOS III command to allow this extension:  
  !control .ext=psize
```

(For more information, see section 2.3 of the Verilog HDL Reference on-line help file)

B.2.1.7.20 Null statements:

example:

```
module foo;
  initial
  begin ;
```

SILOS III command to allow this extension:

```
!control .ext=nstmt
```

(For more information, see sections 8.7.1 of the Verilog HDL Reference on-line help file)

B.2.1.7.21 Timing checks without edge specifications for selected variables:

example:

```
$recovery( CLR, ...
```

SILOS III command to allow this extension:

```
!control .ext=neref
```

(For more information, see section B.9.6 of the Verilog HDL Reference on-line help file)

B.2.1.7.22 More precision in "\$timeformat" than "`timescale":

SILOS III command to allow this extension:

```
!control .ext=tfmt
```

(For more information, see section B.5.2 of the Verilog HDL Reference on-line help file)

B.2.1.7.23 Missing port connections are set to ground for VCS compatibility:

HyperFault command to allow this extension:

```
!control .skip=.gnd
```

Note: Wires which are otherwise floating still remain HiZ, regardless of "!control .skip".

B.2.1.7.24 VCS compatibility extension for comma at the end of the port list, i.e.: module (xx(a,):

HyperFault command to allow this extension:

```
!control .ext=portcomma
```

B.2.2 Silos III Command Line Usage

B.2.2.1 Commands Overview

The Commands section contains a short overview on command syntax, inputting commands from the in the Command window for the Main toolbar and inputting commands from a data file.

B.2.2.1.1 Command Syntax

Usually, only the first two characters are required when specifying a command. A few commands (e.g. FAN, PRE, PRO) require three letters to prevent ambiguity.

B.2.2.1.2 Inputting SILOS Commands

Most commands are a part of the menu structure. However, a Command window has been provided in the Main Toolbar for SILOS III to enter any command. On Unix, an additional SILOS III executable, "silos", is also provided that run SILOS III from the "Ready" prompt.

B.2.2.1.3 Stopping Processes

To discontinue or stop an interactive process when running SILOS III, such as during a large report that is output to the terminal, enter:

- "Ctrl-C": simultaneously hold down the "Ctrl" key and the "C" key on the keyboard for the Unix command-line version of HyperFault.
- "Esc" key on the keyboard for all Windows versions.
- "STOP" button on Toolbar for all Windows versions.

B.2.2.2 Activity Report For Nodes

The ACTIVITY command pre-grades the test vectors for fault simulation by reporting nodes that have no activity (level transitions) during a logic-simulation for the test vectors. The logic simulation is much faster to run than fault simulation.

The ACTIVITY command can also be used as an HDL code coverage report. This section of the Activity report lists the number of times that each line of HDL code was executed as specified by the MXTRAN and MNTRAN keywords.

To obtain a node activity report, enter:

```

TYPE
STORE      ACTIVITY [t1 TO t2] [ / keywrđ=val, keywrđ..]
WTYPE
NSTORE
    
```

where:

| | |
|-----------------|-----------------------------------------------------------------------------------------------------------------------------------------------------------------------------------------------------------------------------------------------------------------------|
| TYPE | optionally directs the activity report to standard output or to a disk file. |
| STORE | ... |
| ACTIVITY | generates a node activity report. |
| t1 TO t2 | represent the minimum and maximum time point values for reporting node activity. This time point range must be within the logic simulation time point range. If the time points are not specified, the logic simulation times are used. (The TO keyword is optional). |
| keywrđ | represents an optional keyword used to define a condition or specify a value. The first keyword must be preceded by a slash. |

Allowed keywords are:

| | |
|-------------------|----------------------------------------------------------------------------------------------------------------------------------------------------------------------------------------|
| BLOCK | reports the activity only for nodes that are included within fault blocking. |
| MNTRAN=val | specifies the lower limit for reporting node activity. Only nodes which have known level transitions greater than or equal to this minimum limit will be reported. (Default: MNTRAN=0) |
| MXTRAN=val | specifies the upper limit for reporting node activity. Only nodes which have known level transitions less than or equal to this maximum limit will be printed. (Default: MXTRAN=0) |
| val | represents the user-specified numerical value for MNTRAN or MXTRAN. |
| NOHIST | suppresses output of the activity versus time histogram. |
| NOSUM | suppresses output of the activity summary. |
| NOTAB | suppresses output of the node activity table. |

Application Notes:

1. An ACTIVITY report can be very useful for developing input test patterns to detect circuit faults for fault simulation. The number of level transitions at a node indicates an input test pattern's effectiveness. Faults at nodes which make no level transitions cannot be detected.
2. The "/s ACTIVITY" command can be used to generate the following reports:
 - An activity table that lists the node names and their number of level transitions. Either single output nodes or wired nodes are listed whose level transition count falls between the ACTIVITY report "MNTRAN" and "MXTRAN" values.
 - An activity summary that lists totals for the number of nodes at each level of activity count.
 - An activity histogram that shows known and potential level transitions versus time.
3. A "known" transition is defined as a change from a Low to High level or High to Low level, even if it goes through an intermediate Unknown level. A "possible" transition is defined as a change from a High or Low level to the Unknown level or from the Unknown level back to a High or Low level.

Examples:

```
ST ACT
ST ACTIV 400 TO 2000
store act 0 to 10000 /MXT=1
STO AC .5K 2.5K /NOTAB
ty ac / nos mxtran=10 mntran=3
```

B.2.2.3 Bus Contention Report

The BUSCON command reports the logic simulation time points at which more than one "tri", "triand", "trior", "trireg", "tri0", or "tri1" net types, or an enabled unidirectional device ("bufif1", "bufif0", "notif1", "notif0", "nmos", "pmos", "rnm0s", and "rpms" devices) are simultaneously driving a node (a bus contention).

To obtain a bus contention report, enter:

```
TYPE
STORE BUSCON [ t1 TO t2 ]
WTYPE
NSTORE
```

Where:

| | |
|----------|--------------------------------------------------------------------------------------------------------------------------------------------------------------------------------------------------------------------------------------------------------------|
| TYPE | (optional) Directs the bus contention report to standard output, or to a disk file. |
| STORE | |
| ... | |
| BUS-CON | Generates a summary table of any contentions that have occurred between two time points. |
| t1 TO t2 | Represent the minimum and maximum time point values over which contention is to be checked. These time values must be within the logic simulation time point range. If not specified, the simulation time points will be used. The keyword "TO" is optional. |

Application Notes:

1. Contentions are reported only for nodes where two or more enabled unidirectional devices, or "tri", "triand", "trior", "trireg", "tri0", and "tri1" net types, form a wired connection (often used to form a bus). Bi-directional transistors, non-enabled gates and gates without enable lines are ignored by the BUSCON report.
2. For each contention, the BUSCON command reports the starting and ending time points, the starting and ending node states, and the names of the enabled unidirectional devices or "tri", "triand", "trior", "trireg", "tri0", and "tri1" net types connected to the node.

Examples:

```
TYPE BUSCON 2K 100K
nst busco
```

B.2.2.4 Encrypting Library Files

The CHGLIB command changes files of Verilog HDL modules and SILOS III macro definitions from sequential access libraries to random access libraries. The CHGLIB command can also be used to encrypt and secure library files.

```
CHGLIB [ / ENCRYPT] [ / SECURE=feature] [ / NODEMOLIMIT] output_file
infile1 ...
```

CHGLIB converts or encrypts library files to random access.

Extensions

| | |
|-----------------------|-----------------------------------------------------------------------------------------------------------------------------------------------------------------------------------------------------------------------------------------------------------------------------------------------------------------------------------------------------------------------------------|
| ENCRYPT | the resulting library file is unreadable except by the SILOS III program. Readable comments can be added by editing the encrypted library file before the first "#" character. Use of this option is controlled by a security license feature issued by Simucad. |
| SECURE=feature | the resulting library file is unreadable except by the SILOS III program. When SILOS III attempts to access the resulting library file, the user must have the "feature" listed in the license file "silos.lic" for SILOS III. The "SECURE" option does not require the "ENCRYPT" option to encrypt the file. The "SECURE" option can also be used with the "NODEMOLIMIT" option. |
| NODEMOLIMIT | the resulting library file is unreadable except by the SILOS III program. This is a special option that allows the demo version of SILOS III to read a library file of more than 200 gates. Use of this option is controlled by a security license feature issued by Simucad. |
| output_file | name of the output library file to be created by the CHGLIB command. |
| infile1 ... | name(s) of one or more input files to be converted to random access and encrypted. |

Application Note:

- Using the CHGLIB command will not necessarily result in a increase in speed, as SILOS III automatically indexes a library file that is sequential access the first time it is used.

Examples:

```
chglib cmos12.lib cmos12.dat cmos13.dat cmos14.dat
chglib /encode chip.library chip.dat
```

B.2.2.5 Control Parameters For Logic Simulation

The "CONTROL" command enables you to modify the parameters that control logic simulation.

The general format of the CONTROL command is:

```
CONTROL .COMMENT=c .CUSTREPORT .DISK=val
+ .DISABLECACHE .DMIN .DMAX
+ .EUNK=val .MXITR=val .MXDCI=val
```

```

+      .NONCON      .SAVCELL=val   .SAVSIM=val
+      .SYNONYM=val .TPS=qual    .XL_ORDER=val
+      .SKIP=val
    
```

val represents the numerical value assigned to the control parameter.

c represents a single character.

string represents the prompt string.

control indicates that the default simulation control parameters are to be modified.

.COMMENT specifies the comment character. (Default: **.COMMENT=\$**)

.CUSTREPORT specifies that the save-file will be used in a Custom Report. (Default: not specified)

.DISABLECACHE turns off the caching mechanism for the Data Analyzer. Turning off the caching may reduce the RAM memory used by SILOS III, however, it may make the Data Analyzer slower. The cache is used to "remember" in RAM memory the simulation data that you have viewed with the Data Analyzer. For example, if you do a zoom full, then every change for the displayed signals is stored in memory. If you then zoom in or zoom out for these signals, the redraw time is much faster. If you add additional signals to the Data Analyzer, then the simulation data for the new signals has to be read from the simulation history save file on disk.

.DISK assigns the approximate limit of disk storage in bytes that the simulation save-file can use. When the disk storage limit is exceeded, the simulation will terminate (see note 1). (Default: **.DISK=100M**)

.DMAX Specifies that the maximum delay value will be used when parsing the netlist (see note 2).

.DMIN Specifies that the minimum delay value will be used when parsing the netlist (see note 2).

Extensions

| | |
|------------------|-----------------------------------------------------------------------------------------------------------------------------------------------------------------------------------------------------------------------------------------------------------------------------------------------------------------------------------------------------------------|
| .EUMK | Defines the conductance for bi-directional transistors and unidirectional transfer gates when there is an Unknown level on the enable: "on" when .EUNK=1, "off" when .EUNK=0 or "Unknown" when .EUNK=*. (See note 3) (Default: .EUNK=*) |
| .NONCON | When nonconvergence is detected, the default is for SILOS III to issue a warning message, pick a possible solution if this is possible, and continue simulation. If the "CONTROL .NONCON" command is entered before logic initialization begins, then if nonconvergence is detected, SILOS III will issue an error message and stop the logic simulation. |
| .MXDCI | Assigns the maximum allowed iterations for each pass during LINIT. (See note 4) (Maximum: .MXDCI=9999) (Default: .MXDCI=100) |
| .MXITR | Assigns the iteration limit to reach convergence for each logic simulation time point. (See note 4) (Maximum: .MXITR=999) (Default: .MXITR=300) |
| .SAVCELL | Causes SILOS III to not save (".SAVCELL=0") or to save (".SAVCELL=1") the simulation history for variables listed between the 'celldefine and 'endcelldefine compiler directives. Caution: Saving all variables between 'celldefine and 'endcelldefine compiler directives may slow down simulation and create larger save files on disk. (Default: .SAVCELL=0) |
| .SAVSIM | Sets the logic simulation save option to determine which simulation node state changes are saved on the "SAVE" disk file. The .savsims option must be specified before simulation begins. (Default: .SAVSIM=0) |
| .SAVISM=0 | Specifies that no simulation node values are to be saved. This has limited use, as no data is available. |
| .SAVISM=1 | Specifies that node simulation values (logic-type, integer-type and double-type) are to be saved only for nodes named in the TABLE, PLOT, GNAME, TESTER, KEEP, MKEEP, HEX and OCT commands. Output results can be obtained only for the saved nodes. This option decreases simulation disk file size and reduces execution time. |
| .SAVISM=2 | Specifies that all logic-type simulation node states are to be saved for all nodes in the circuit. This option prevents saving integer and floating-point values. |

| | |
|----------------------|----------------------------------------------------------------------------------------------------------------------------------------------------------------------------------------------------------------------------------------------------------------------------------------------------------------------------------------------------------------------------------------------------------------------------------------------------------------------------------------------------------------|
| .SAVSIM=3 | Specifies that all (logic-type, integer-type and double-type) simulation node values are to be saved. Output values can be retrieved for any network node. |
| .SYNONYM | Causes SILOS III to retain the hierarchical node names (synonyms) in addition to the "real" node name for the upper-most level that the node is connected to in the hierarchy. When all synonyms are saved, SILOS III will recognize the hierarchical name as well as the "real" name to each node in the design. Caution: Saving all synonyms may slow down input parsing and memory usage may go up. (Default: .SYNONYM=1) .SYNONYM=0 Don't save synonyms. .SYNONYM=1 Save all synonyms. |
| .SKIP | Causes SILOS III to set a skipped port to a level. The default level is High-Z unknown. An allowed level is ground for compatibility with VCS (!control .skip=.gnd). . (Default: .SKIP=.gnd) |
| .TPS | Specifies the default command for redirecting report outputs to standard output or disk file. Allowed qualifiers are: TYPE, WTYPE, STORE, NSTORE |
| .XL_ORDER=val | Specifies a switch so that the order of evaluation for always blocks is the same order as for Verilog-XL, where "val" is "1" for "xl_order" being "on" (the same as Verilog-XL) and "0" for xl_order being "off" (default). This switch may be useful for obtaining the same simulation results as Verilog-XL. This option must be parsed before any modules are parsed. An example would be the order of evaluation for: always @posedge clock always @posedge clock |

Application Notes:

1. When the disk storage limit (set by ".CONTROL .DISK") is exceeded during logic, the simulation will stop. A message will be displayed showing the last simulation time point. To continue the simulation, you can increase the disk limit and re-enter the "SIMULATE" command. Another method would be to report the simulation results, enter "RESET SAVFILE" to clear the disk file "save.sim" (saves the simulation history) and then continue from the last simulation time point. "RESET ERRORS" must be entered before continuing the simulation.
2. .DMAX and .DMIN will not both affect the same simulation. The one that is specified last will remain in effect for all netlist parsing and subsequent SIMULATE commands.

The .DMAX or .DMIN scaling factor should be specified before inputting the netlist so that the netlist is parsed correctly.

3. If ".CONTROL .EUNK=*" has been defined and there is an Unknown level on the gate's enable, MOS transistors will have an uncertain conductance and interval logic will be used to resolve their source and drain (see Interval Logic: Resolving Uncertain Strength at a Node in the Logic Simulation chapter). Transfer gates also have an uncertain conductance and their output will be resolved using interval logic. For tri-state gates, the output level will be set to Unknown. The output strength will be defined by the gate definition for a tri-state gate.
4. When the iteration limit is exceeded for ".CONTROL .MXDCI" or ".CONTROL .MXITR", a nonconvergence error stops execution. Nonconvergence may be due either to circuit path length or problems with designs involving feedback. To eliminate oscillations caused by problems involving feedback, the circuit design must be corrected. When nonconvergence is due to path length, increasing the iteration limit should enable the circuit to converge. In general, each node in the serial path length requires one iteration to propagate a signal. Arbitrarily increasing the iteration limits is not recommended as it may dramatically increase the execution time necessary to identify oscillating nodes.
5. The "NONCONV" command can be used to identify which parts of the circuit have caused a logic initialization or logic simulation to stop executing.

Examples:

```
!con .mxd=200 .mxp=200
CON .DISK=2M .MXOSC=30 .EUNK=*
```

B.2.2.6 Default Device Delay Times

Normally, if a device has no delay specification, the delay times default to zero. The DELAY command allows you to globally redefine the default values.

Default delay times are specified as follows:

```
DELAY .DEFAULT = d1, d2
```

| | |
|--------------|---------------------------------------------------------------------------------------------------------------------------|
| DELAY | Indicates a default delay time specification. |
| .DEFAU LT | Indicates that the default times for all unspecified delays are to be assigned. Normally, the default delays are d1=d2=0. |
| d1 | Represents the nominal rise delay time where: "d1" must be an integer between 0 and 10000. |

d2 represents the nominal fall delay where:"d2" must be an integer between 0 and 10000.

Examples:

```
!DEL .DEF = 16,5

!del .default=0, 0
DISK
```

B.2.2.7 Disk File Name Reassignment

The DISK command enables you to change the default file name for the "STORE"/"NSTORE" commands.

To change the "STORE/NSTORE" disk file name, enter:

```
DISK filename
```

| | |
|-------------|----------------------------------------------------------------------------------------------------------------------------------------------------|
| DISK | Changes the "STORE/NSTORE" disk file name. If no file name is specified, the program will tell you the name of the present default disk file name. |
| filename | Represents the name of the disk file to which STORED output will be written.filename="store.out") |

Application Notes:

1. Whenever a DISK command is specified, any STORED data will be written to that disk file until another file name is specified.
2. Each time a STORE or NSTORE command is specified, any existing data on the "DISK" file in effect may be overwritten (default), appended or a new cycle will be created.
3. The file name can be unlimited in length, but must conform to the file name syntax of your operating system. For the UNIX operating system, the file name is case sensitive.
4. The "FILE .STO=" command can also be used to change the default file name.

Examples:

```
DISK sim.results
DI PATTERN.INP
ERRORS
```

B.2.2.8 Error Summary

When the program indicates that errors occurred during read-in, preprocessing or simulation, you should enter the "t/s ERRORS" command to determine their error level and type. For input errors, the line number and the input file name will also be reported.

To check the errors, enter:

```
TYPE
STORE ERRORS [ / LEVEL=value ]
WTYPE
NSTORE
```

| | |
|--------|--------------------------------------------------------------------------------------------------------------------------------------------------|
| TYPE | (optional)Directs the error messages to standard output. |
| STORE | Directs the error messages to a disk file. |
| ... | |
| ERRORS | Reports any error and warning messages. |
| LEVEL | (optional)Indicates that only those errors with a severity level equal to "value" are to be output. If not specified, all errors will be output. |
| value | Represents a value from 1 to 5. |

Examples:

```
STOR ERROR / LEVEL=2
ty er
```

B.2.2.9 Exclude Saving Simulation Node States

The EXCLUDE command specifies nets whose state values will not be saved during simulation. To exclude registers, see "B.2.2.13 Exclude Saving Module Instance Variable Values"

The format for the EXCLUDE command is:

```
EXCLUDE name name ... name
```

| | |
|---------|------------------------------------------------------------------------|
| EXCLUDE | Specifies nets whose state values will not be saved during simulation. |
|---------|------------------------------------------------------------------------|

name Represents the name of a net whose state changes will not be saved during simulation.

Application Notes:

1. The KEEP command can be used to specify nets whose simulation states are to be saved. The MKEEP and MEXCLUDE commands will keep and exclude all variables (including registers and memory variables) within a module or macro instance.
2. The effects to the KEEP and EXCLUDE commands are cumulative. When an identical net name is specified in more than one KEEP or EXCLUDE command, the last KEEP or EXCLUDE command will determine if the simulation states for that net are saved.
3. The KEEP, EXCLUDE, MKEEP and MEXCLUDE commands can be used with the "CONTROL .SAVSIM=1" command option to save simulation state values.

Examples:

```
CONTROL .SAVSIM=1

EXCLUDE (REG15(QBAR A15
.exclude (m1(bit0 (m1(bit1
+ (m1(bit4 (m1(bit5 (m1(bit6 (m1(bit7 (driver
+ (iobuf(pin34
```

B.2.2.10 Exiting The Program

The "EXIT" command is used for normal exit of SILOS III.

To exit the program, enter:

```
EXIT
```

EXIT commands the SILOS III program to stop execution and exit normally.

Example:

```
EXI
FILE
```

B.2.2.11 File Name Specification

The FILE command enables you to redefine the default file names used for the SAVE, STORE and BATCHFILE commands.

The format for the FILE command is:

```
FILE    [.SAV=filename]    [.STO=filename]    [.BAT=filename]
+      [.MODE=.APPEND]    [.MODE=.OVERWRITE]
```

| | |
|--------------|-------------------------------------------------------------------------------------------------------------------------------------------------------------------------------------|
| FILE | redefines the file name defaults. |
| .SAV | changes the file name prefix "save" to a user specified name for all of the save files, including the save.dictionary file. |
| .STO | changes the file name for subsequent STORE and NSTORE commands. |
| .BAT | changes the default BATCHFILE command file name. |
| .MODE | specifies whether a report STOREd will either append to the existing .STO file (or DISK command file) or overwrite the .STO file. (Default: .MODE=.OVERWRITE) |
| filename | represents the redefined name of the file. A file name can be unlimited in length. However, the name must conform to the syntax of your operating system. |

Application Notes:

1. The "FILE .SAV" command must be entered before using a FSIM command. Do not specify a file name extension; the program will automatically provide the correct extensions. (Default: filename=SAVE)
2. The "FILE .STO" command is equivalent to the DISK command. (Default: filename=STORE.OUT or STORE OUTPUT)

3. A file name specified on a subsequent BATCHFILE command will override the "FILE .BAT" command.

Example:

```
file .sav=run5
```

B.2.2.12 Keeping Simulation Node States

The KEEP command specifies wires whose state values will be saved during simulation. To save state values to registers, see "B.2.2.14 Keeping Module Instance Simulation Variable Values".

The format for the KEEP command is:

```
KEEP name name ... name
```

| | |
|-------------|-----------------------------------------------------------------------------------|
| KEEP | specifies wires whose state values will be saved during simulation. |
| name | represents the name of a wire whose state changes will be kept during simulation. |

Application Notes:

1. The EXCLUDE command can be used to specify wires to be excluded from the saved simulation results.
2. The MKEEP and MEXCLUDE commands will keep and exclude all variables (including registers and memory variables) within a module or macro instance.
3. The effects to the KEEP and EXCLUDE commands are cumulative.
4. The KEEP, EXCLUDE, MKEEP and MEXCLUDE commands can be used with the "CONTROL .SAVSIM=1" option.

Examples:

```
CONTROL .SAVSIM=1
KEEP (MAC15 (REG08 (MAC1 (MEM (ADDR01
.keep (m1(bit0 (m1(bit1 (m1(bit2 (m1(bit3
+ (m1(bit4 (m1(bit5 (m1(bit6 (m1(bit7
+ (iobuf (pin34
```

B.2.2.13 Exclude Saving Module Instance Variable Values

The MEXCLUDE command excludes the internal variable values from being saved during logic simulation for module instances and macro expansions and any variable that is hierarchically below the excluded module instance or macro expansion.

The format for the MEXCLUDE command is:

```
MEXCLUDE  mname      mname      . . .      mname
```

MEXCLUDE Specifies module instances and macro expansions that will not have their internal variables and any variable that is hierarchically below the excluded module instance or macro expansion saved during logic simulation.

mname represents the name of a module instance or macro expansion.

Application Notes:

1. The MKEEP command can be used to specify module instances and macro expansions for which the simulation state values to all variables are saved.
2. The effects to the MKEEP and MEXCLUDE commands are cumulative.
3. The KEEP, EXCLUDE, MKEEP and MEXCLUDE commands can be used with the "CONTROL .SAVSIM=1" option.

Examples:

```
CONTROL .SAVSIM=1
MKEEP (mac1(a
MEXCLUDE (mac1(a(c

!mexclude (m1(bit0 (m1(bit1 (m1(bit2 (m1(bit3
+ (m1(bit4 (m1(bit5 (m1(bit6 (m1(bit7 (driver
+ (iobuf(pin34
```

B.2.2.14 Keeping Module Instance Simulation Variable Values

The MKEEP command saves the logic simulation state values for all variables in the specified module instances and macro expansions, and the state values for all variables hierarchically below each specified module instance and macro expansion.

The format for the MKEEP command is:

```
MKEEP mname mname ... mname
```

MKEEP specifies module instances and macro expansions whose logic simulation state values will be saved for all variables in the specified module instance and macro expansion, and for all variables hierarchically below each specified module instance and macro expansion.

mname represents the name of a module instance or macro expansion.

Application Notes:

1. The MEXCLUDE command can be used to specify module instances and macro expansions whose internal variables will not be saved during logic simulation.
2. The effects to the MKEEP and MEXCLUDE commands are cumulative.
3. The KEEP, EXCLUDE, MKEEP and MEXCLUDE commands can be used with the "CONTROL .SAVSIM=1" option.

Examples:

```
CONTROL .SAVSIM=1
MKEEP (mac1 (a (b

.mkeep (m1(bit0 (m1(bit1 (m1(bit2 (m1(bit3
+ (m1(bit4 (m1(bit5 (m1(bit6 (m1(bit7 (driver
+ (iobuf(pin34
```

B.2.2.15 Nonconvergence Summary

The "t/s NOCONV" command generates a report of any nonconverged nodes and their oscillating states for the time point that nonconvergence occurred.

To obtain a nonconvergence summary for nodes and devices, enter:

```

TYPE
STORE           NOCONV [ / INPUT   ITER=val ]
WTYPE
NSTORE

TYPE . . .

```

TYPE (optional) directs the nonconvergence table to standard output
STORE or to a disk file.

NOCONV reports the oscillating states for nonconverged nodes.

INPUT (optional) reports the states for all inputs of devices which drive the oscillating nodes.

ITER=val (optional) specifies the iteration number to the 1st of eight states for each node reported for nonconvergence. The default iteration for 'val' is computed such that the last of the eight states reported corresponds to the last iteration simulated before no convergence halted the simulation.

Application Notes:

1. The "t/s NOCONV" command can be used to identify which parts of the circuit have caused a logic initialization or logic simulation to nonconverge.
2. The "t/s NOCONV" command reports the following information:
 - names of the unresolved devices and nodes.
 - the "type" of device and node as either a ".type" data keyword, "NODE" for a wired connection with at least one bi-directional device or "BUS" for a wired connection between two or more unidirectional enabled gates.
 - the node state values for the nonconvergence time point. State values reported are preceded by a "..." to indicate possible previous states.

3. Nonconvergence only occurs when gate delays are zero. Zero-delays occur during logic initialization , which forces delays to be zero; or, during zero-delay logic simulation ; or, when either zero delay or no delay is specified for devices (the default delay for Verilog HDL devices is zero).
4. When the iteration limit is exceeded while resolving node states at a time point, a nonconvergence error stops execution. Nonconvergence may be due either to the circuit path length or problems with designs involving feedback. The circuit design must be corrected to eliminate oscillations caused by problems involving feedback. When nonconvergence is due to path length, increasing the iteration limit should enable the circuit to converge. In general, each node in the serial path length requires one iteration to propagate a signal.
5. The maximum iterations per pass for logic initialization can be redefined by the "CONTROL .MXDCI" command. The maximum iterations at a time point for logic simulation can be redefined by the "CONTROL .MXITR" command. Arbitrarily increasing these parameters is not recommended as it may dramatically increase the execution time necessary to identify oscillating nodes.
6. The maximum number of passes for logic initialization is defined by the "CONTROL .MXPAS" command. When this limit is exceeded, the error message specifies the required number of passes to complete logic initialization. To reduce the number of passes and execution time, use ".INIT" to preset the state for critical nodes. Although arbitrarily setting "CONTROL .MXPAS" to a large value will very likely converge a circuit that is theoretically solvable, this is not recommended as the problem is usually due to incorrect circuit design.

Examples:

```
ty noc
```

```
nocon /iter=43
```

B.2.2.16 Narrow Storing Outputs

When a command that generates a report is preceded by the NSTORE command, the report output will be directed to a disk file.

To specify the NSTORE command, enter:

```
NSTOREcommand ...
```

NSTORE directs the output to a 79 column disk file. As a default, this file is named "store.out".

Extensions

`command` represents a command structure which defines the type of data to be output. These commands are described within this section of the manual.

Application Notes:

1. If a command that generates a report is not preceded by the `NSTORE` command, then the default output device is specified by the `CONTROL` command.
2. To respecify the page width for the `NSTORE` command, use the "`FORMAT .NSTORE`" command.
3. The default file name for the `NSTORE` command may be redefined using the `DISK` command or the "`FILE .STO=`" command.

Examples:

```
nstore output on change
```

```
NSTO NETWORK /FDD
PREPROC
```

B.2.2.17 Preprocessing Data

Normally, data preprocessing is automatically performed prior to initialization or simulation (i.e., when the `SIMULATE` command are entered). However, you may wish to use the `PREPROC` command to check for syntax errors without simulating.

To preprocess data, enter:

```
PREPROC
```

Application Notes:

1. During data preprocessing, the program resolves and checks all gate input connections, calculates fan-out connections and creates implicit nodes. Generally, the data is reformatted for more efficient simulation.
2. Once preprocessing has been performed, additional topological data cannot be entered.
3. Note that at least the first three letters of this command must be specified (i.e. `PRE`).
4. If serious errors occur during a phase of the preprocessing, you should correct the errors before proceeding. If the errors were corrected interactively, enter "`RESET ERRORS`" and then reissue the `PREPROC` command to continue preprocessing.

```
probe
```

B.2.2.18 Probing Node States

The probe command reports the value of variables and expressions in tabular format.

The format for the probe command is:

```

STORE probe          t1 t2  "format"  (expression), expres-
sion ...
STORE probe ITER    t1 t2  "format"  (expression), expres-
sion ...
STORE probe STEP dt t1 t2  "format"  (expression), expres-
sion ...

```

| | |
|------------|-----------------------------------------------------------------------------------------------------------------------------------------------------------------------------------------------------------------------------------------------------------------------------------------------------------------------------------------------------------------------------------------------------------------------------------------------------------------------|
| STORE | (optional) directs the probe output to a disk file. Use the DISK command to specify the file name for the stored output. |
| probe | reports the value of variables and expressions in tabular format. (Default: report the "on change" values) |
| STEP dt | (optional) causes the values to be reported between time "t1" to time "t2" at intervals of "dt". |
| ITER | (optional) causes values of variables and expressions to be reported for each iteration at a time point. |
| t1 t2 | (optional) represents an optional time point range over which the values will be reported. When "t1" and "t2" are not specified the probe command will use the simulation time values or the time values specified on the last probe command. |
| format | (optional) specifies the format for reporting the expressions. Any of the format specifications for \$display and \$monitor are allowed (Default radix: %h) |
| expression | specifies any legal Verilog HDL expression. The parentheses around the first specified expression are not required when it is just a single variable. Full hierarchical path names can be used, otherwise the module instance selected by the "SCOPE" command will be used. A ",", can be used instead of a name to insert a blank column in the report. When an "@" sign is used in front of any expression, then values are reported when those expressions change. |

Extensions

Examples:

A typical way the probe command can be used is to declare the scope for a module instance, and then list variables in the module that you want to report on. Using two commas between variables would leave a blank column between variables:

```
scope main// declare module instance "main".
pro a,,b,,c// blank column between variables.
```

The probe command can be used to report the value for any expression, such as, you could use the following probe command to report the value for the assignment "out= (a+b) | (c+d)" for each change of variable "clock":

```
probe @clock,, "out=", (a+b) | (c+d)
```

The STORE command can be used to store the probe report to a file:

```
store probe a,b// stores the probe report to a file.
```

Some additional examples for the probe command are listed below:

```
probe main.i1.a// report variable "a" inside instance "main.i1"
probe "output result = %o", out// use string and octal radix formats.
probe 0 100 %o{a,b,c}// report concatenated variables as octal
store probe %b a[0:2], %h a[3:6]// vary the radix for reporting values.
```

B.2.2.19 Quitting Execution

The QUIT command enables you to terminate an unwanted session without that session affecting any active SAVE files.

To quit program execution, enter:

```
QUIT
```

Application Notes:

1. The QUIT command aborts execution of the program and all program results since the last SAVE command are lost.

B.2.2.20 Resetting Selected Data

The RESET command can be used to reset (i.e. delete) selected data information for the command line version of SILOS III. For the graphical interface version, the Silos Simulation Environment, use the Load/Reload Files button.

The form of the command is:

```

RESET ALL
ERRORS
OUTPUTS
PATTERN
SAVFILE

```

| | |
|----------------|--------------------------------------------------------------------------------------------------------------------------------------------------------------------------------------------|
| RESET | Resets selected program counters and/or flags as specified by the below options. |
| ALL | Resets everything (as if you just began execution). The program will not issue a warning. |
| ERRORS | Deletes data error flags and messages up through level 4. This can be used to continue a simulation after errors have been corrected, and to clear unnecessary warning and error messages. |
| SAVFILE | Resets the logic simulation save file data to eliminate disk storage. |

Application Notes:

1. For RESET OUTPUTS, new output commands can be entered from the menu selections or input from a file.
2. Before using "RESET SAVFILE", reports should be generated and/or the SAVE files should be copied to tape. After "RESET SAVFILE", logic simulation can be continued from the last simulation time point but output reports are not available for simulation results prior to the last simulation time point.

Examples:

```

RES ERR

res savfile

```

B.2.2.21 Scope For Printing Module Variables

The SCOPE command declares the module instance used when the PRINT or probe commands reports the values for variables and expressions in a module.

The format for the SCOPE command is:

```
SCOPE instance_name
```

| | |
|---------------|-------------------------------------------------------------------------------------------------------------|
| SCOPE | Declares the module instance used by the PRINT or probe command |
| instance_name | Represents the instance name for the module whose variables will be reported by the PRINT or probe commands |

Example:

```
SCOPE main.cpu.cache
```

B.2.2.22 Logic Simulation Specification

Logic simulation can be performed by entering the SIMULATE command.

To initiate the logic simulation, enter:

```
SIMULATE t1 [ TO t2 ]
```

| | |
|----------|--------------------------------------------------------------------------------------------------------------------------------------------------------------------------------------------------------------------|
| SIMULATE | Performs time-response logic simulation that can use both finite and zero delay specifications. Preprocessing (PREPROC) and logic initialization will be automatically performed if they have not been previously. |
| t1 TO t2 | Represent the values of the first and last simulation time points (see note 1 below). The keyword "TO" is optional. |

Application Notes:

1. When specifying the simulation time point range, the following items apply:

- Specifying neither t1 nor t2 or setting t2 to an arbitrary large number will cause SILOS III to simulate until "\$stop" or "\$finish" is encountered in the netlist. You can stop the simulation by clicking-on the "STOP" button or pushing the "Escape" key (Esc) on the keyboard for the PC and "Ctrl-C" on Unix.
 - Specifying a single time point indicates that simulation will be incrementally continued for that amount of time. At time=0, this will start the simulation from time=0 for the specified amount of time.
 - Specifying t1 and t2, with t1=0, runs the simulation from time=0 to time=t2.
 - Specifying t1 and t2, with t1 greater than zero, continues the simulation from the last specified time point.
 - Specifying "TO t2" will continue the simulation until time=t2. This can be useful to continue a simulation that was halted due to a breakpoint.
2. The SIMULATE command will automatically invoke the PREPROC command (if PREPROC has not already been performed) and no further topological data can be entered.
 3. Simulation can either be continued from the last time point or restarted from time=0.
 4. The SIMULATE command uses inertial delays, which do not propagate level changes that occur faster than the gate output can change (spike condition).

Examples:

```
simul 0 to 22k
SIM 5KGG 10K
SIM 5K
sim 0 15k
SI TO 5K
```

B.2.2.23 Size-Of-Data Reprint

The SIZES command reports the memory usage for SILOS III.

To report the network size information, enter:

```
TYPE
STORESIZES
WTYPE
NSTORE
```

```
TYPE (optional) directs the size informa-
STORE tion to standard output
... STORE or to a disk file.
```

SIZES Generates memory usage information

Application Notes:

1. Items reported include the total number of devices, network names, etc.
2. The memory usage may be different after read-in, preprocessing and simulation.
3. The memory usage is also reported in the "Help/About" box.

Examples:

```
NSTO SIZ
TY SIZ
```

B.2.2.24 Spike Summary Output

The "t/s SPIKES" command allows you to view all the nodes on which spikes were made observable during logic simulation (see "B.2.2.22 Logic Simulation Specification").

To generate a node spike summary, enter:

```
TYPE
STORE SPIKES [t1 TO t2]
WTYPE
NSTORE
```

| | |
|----------|--------------------------------------------------------------------------------------------------------------------------------------------------------------------------------------------------------------------------------------------------------------------------------------------|
| TYPE | (optional) Directs the spike summary |
| STORE | to standard output or to a disk file. |
| ... | |
| SPIKES | Lists a summary table of all spikes between two time points. |
| t1 TO t2 | Represent the minimum and maximum time point values over which the spike output is to be generated. This time point range must be within the logic simulation time point range. If the time points are not specified, the logic simulation times are used. (The "TO" keyword is optional.) |

Application Notes:

1. A spike occurs when the gate input level changes faster than the gate output can change.
2. Setting the criteria for spike conditions is controlled by the +pulse_e, +pulse_r, and +path-pulse command line arguments.
3. To enable spike recording during logic simulation for the SPIKE report, use the +silos_spike command line option.

Examples:

```
ty spikes
NSTO SPIKES 4.2K 4.8K
STORE
```

B.2.2.25 Storing Outputs

When a command that generates a report is preceded by the STORE command, the report output will be directed to a disk file.

To specify the STORE command, enter:

```
STORE command ...
```

| | |
|---------|---------------------------------------------------------------------------------------------------------------------------------------------|
| STORE | Directs the output to a 132 column disk file. As a default, this file is named "store.out". |
| command | Represents a command structure which defines the type of data to be output. These commands are described within this section of the manual. |

Application Notes:

1. If a command that generates a report is not preceded by the STORE command, then the default output device is specified by the CONTROL command.
2. To respecify the page width for the STORE command, use the "FORMAT .STORE" command.
3. The default file name for the STORE command may be redefined using the "DISK" command or the "FILE .STO" command.

Examples:

```
store output on change
```

```
STO NETWORK /FDD
```

B.2.2.26 Strength Specification For Gates

The STRENGTH command allows you to modify the default strength types.

To respecify default strength types for gate devices, use:

```
STRENGTH .device/strg .device/strg ...DEFAULT/strg
```

| | |
|----------|-------------------------------------------------------------------------------------------------------------------------------------------------------------------------------------------------------------------------------------------------------------------------------------------------------------------------------------------------------------------------------------------------------------------------------------------------------------------------------------------------|
| STRENGTH | Indicates that default strength-types are to be assigned to unidirectional gate devices. |
| .device | Represents a device keyword (see note 1 below). If no "device/P" or device/strg" is specified for an individual gate device, the program defaults to a "CMOS" strength type. |
| DEFAULT | Sets the strength for all devices that do not have the strength explicitly specified. The default is "CMOS" strength type. |
| strg | Represents any combination of "D", "R" or "Z". The first character indicates the strength of the Low level. The second character indicates the strength of the Unknown level. The third character indicates the strength of the High level. "D" represents Strong strength, "R" represents Pull strength, and "Z" represents High-Z strength. Alternatively, the characters "N", "P" or "C" can be used by themselves to indicate NMOS-type (DRR), PMOS-type (RRD) or CMOS-type (DRD) defaults. |

Application Notes:

1. The "device" keyword can be any of the combinatorial gate devices.
2. Supply-strength cannot be defined.

Examples:

```
!strength .nor/n .nand/n .not/c
```

```
!strength default/ddd
```

B.2.2.27 Symbol Modification For Output

The SYMBOL command allows you to use a unique symbol for each possible logic state.

To modify the output state symbols, use:

```
SYMBOL sc=char sc=char sc=char ...
```

- SYMBOL Specifies that the state code symbols are to be redefined.
- sc Represents one of the state-type codes for the OUTPUT, POUTPUT and probe reports and for the .CLK and .PATTERN stimulus specifications:

| state symbols | state | default report symbol | default stimulus char |
|---------------|------------------------|-----------------------|-----------------------|
| S0 | Supply Low | 0 | 0 |
| S* | Supply Unknown | * | * |
| S1 | Supply High | 1 | 1 |
| SHV | Supply High-Voltage | 1 | |
| D0 | Driving Low | 0 | |
| D* | Driving Unknown | * | |
| D1 | Driving High | 1 | |
| DHV | Driving High-Voltage | 1 | |
| R0 | Resistive Low | 0 | |
| R* | Resistive Unknown | * | |
| R1 | Resistive High | 1 | |
| RHV | Resistive High-Voltage | 1 | |
| Z0 | High-Z Low | Z | |
| Z* | High_Z Unknow | Z | Z |
| Z1 | High-Z High | Z | |
| ZHV | High-Z High-Voltage | Z | |

Extensions

(sc) The following symbols are used only in the output reports. No symbol can be defined to input these states for .CLK or .PATTERN stimulus:

| State Symbols | State | Default Report Symbol | Default Stimulus Char |
|---------------|------------------------|-----------------------|-----------------------|
| *0 | Uncertain Low | * | |
| ** | Uncertain Unknown | * | |
| *1 | Uncertain High | * | |
| HV | Uncertain High-Voltage | * | |
| 0D | Decaying Low | D | |
| *D | Decaying Unknown | D | |
| 1D | Decaying High | D | |
| HVD | Decaying High-Voltage | D | |
| *S | Spike | S | |

char Represents the single character you want to be used to indicate the state. The comment character (default a "\$") cannot be used as a "char" symbol.

Application Notes:

1. Enter the SYMBOL command before the ".PATTERN" and ".CLK" specifications are entered to redefine symbols used for stimulus state values.
2. The SYMBOL command can redefine node state symbols either before or after simulation for the "t/s OUTPUT", probe, and "t/s POUTPUT" reports.
3. When the same symbol is used to represent the different states (as in the defaults of 0,*,1) for the input stimulus for a .CLK or .PATTERN specification, the program resolves the ambiguity in the following order:
 - The most recent symbol specified by the most recently entered SYMBOL command is used.
 - For the default symbols not specified by a SYMBOL command, the higher strength is used and within a strength, the higher level is used.

For example, if "SYMBOL D1=+ R0=+" is entered, then the symbol "+" would mean Resistive Low. If "SYMBOL D1=+ D*=+" is entered, then the symbol "+" would mean Driving Unknown.

4. Note that the Unset state symbol cannot be changed; it will always be a question mark "?".

Examples:

```
SYMBOL Z0=- Z*=# Z1=+
.symbol r*=U z*=U d*=U r1=H z1=H d1=H d0=L
+ r0=L z0=L
SYM 0D=L *D=U 1D=H S0=O S*=X S1=I
!SYM D0=O D*=X D1=I *S=^
```

B.2.2.28 Batch Execution Overview

SILOS III can be run on the host computer as:

- An interactive session for debugging a design;
- A batch session for running regression tests.

Running SILOS III as a batch execution may be useful for:

- Running regression tests.

This section explains how to run SILOS III as a batch execution in the Windows 95, Windows 98 operating system, Windows NT operating system or the Unix operating system. Examples are provided for common tasks such as using SILOS III commands from a file to input and simulate the netlist, and report simulation results.

Before reading the sections on running as a batch execution, you may want to review the section on "B.2.2.1 Commands Overview" to gain a better understanding of how to use SILOS III commands.

B.2.2.28.1 Commands in Files

SILOS III commands can be entered in the Command window for the Main toolbar (for more information, see "B.2.2.1 Commands Overview") or from a file. Commands entered from a file must be directly preceded (without any white space) by a "!" or a ".". Preceding a command by "!" will cause the command to be echoed to standard output as it is executed. Usually, only the first two characters are required when specifying a command. A few commands (e.g. PRE, PRO) require three letters to prevent ambiguity. For more information on the commands available for SILOS III, see the "B.2.2 Silos III Command Line Usage".

An is shown below. For this example, file "test.v" will automatically simulate to the \$finish and report any error messages. Enclosing SILOS III commands with a "ifdef silos" compiler

directive allows you to maintain Verilog compatibility (the keyword "silos" is defined as true by default in SILOS III).

```
File "test.v":
//title simple circuit
module foo;
    reg clock;
    initial
        begin
            clock = 0;
            #10 clock = 1;
            #10 $finish;
        end
endmodule
'ifdef silos
    !sim
    !errors
'endif
```

Commands are executed immediately upon being encountered in the data. Therefore, the order in which the commands are placed may be important (e.g., !PREP before !SIM).

You should use the 'include compiler directive when inputting a file from another file. In the previous example, remove the SILOS III commands from the file "test.v" and put them in file "test1.v" (shown below) with an 'include compiler directive to include file "test.v" (for additional information see 'include in the Verilog HDL Reference on-line help file).

```
File "test1.v"
'include "test.v"
'ifdef silos
!sim 200
!errors
'endif
```

B.2.2.28.2 Command-line Options

You can use Verilog style command line arguments for SILOS III. The command line arguments can be entered from the Command Line Arguments box in the Project Settings dialog box (see "B.3.5.8 Project/Project Settings"), or, from the command line if you are running a batch simulation. Available command line arguments are:

- **-c**: This option compiles the source files and then exits.
- **-f file_name**: This option instructs SILOS III to get the command line arguments from a file. SILOS III has the ability to nest the command files. For example, command file "logicsim", `silos -f logicsim`, could contain the name of another command file "logicsim1" that has additional "-" command line arguments.

SILOS style commands can be entered in a command file by enclosing the command with double quotes `!"silos_command"`, i.e. `!"control .sav=2"`.

- `-k file_name`: This option saves the text that has been entered from standard input to a file.
- `-l file_name`: This option writes the standard output from SILOS III to a log file. An "exit" or "quit" command must be encountered for SILOS III to terminate.
- `-la`: This option appends the standard output from SILOS III to a log file instead of overwriting the log file, and also to standard output. This option must appear before the `-l <fn>` option.
- `-r save_file_name`: This option restores SILOS III to the last saved simulation state from a previous SILOS III save command.
- `-s`: This option causes SILOS III to enter the interactive mode after executing any commands that have been input to SILOS III.
- `-u`: This option converts every name to upper case.
- `-v file_name`: This option specifies a library file name.
- `-w`: Specifying `-w` means that SILOS III will not display any warning messages.
- `-y directory_path`: This option specifies a directory of library files.
- `+libext+extension1+extension2...`: This option names the file name extensions for library files in the directory specified by the `-y` option. An example of specifying the library path and extension would be: `-y c:\silos3\examples\library +libext+.v`
- `+libnonamehide`: This option causes SILOS III to read in the module and UDP definition names as they are written in the file without appending character strings.
- `+librescan`: Search all the library files again for undefined modules.
- `+libverbose`: This option prints information about the opening of files and the resolution of module and UDP definitions during the scanning of libraries.
- `+define+text_macro_name=macro_text`: This option allows you to specify ``define` macros from the command line. The `"text_macro_name"` is the macro identifier, and the `"macro_text"` is the text substitution. Double quotes (" ") must be used around the `macro_text` if the `macro_text` contains whitespace. For example: `silos.exe +define+sdf=test.sdf`, is equivalent to: ``define sdf test.sdf` and: `silos.exe +define+declare="reg a;"` is equivalent to: ``define declare reg a;`
- `+delay_mode_distributed`: Command line argument specifies the distributed delay mode for all modules in the source description. This means that the distributed delays for gates connecting the module input to the module output will always be used as the pin-to-pin delay for the module input to output. For examples of distributed delays, see Chapter 13 on specify blocks in the Verilog LRM on-line help file.
- `+delay_mode_path`: Command line argument specifies the path delay mode for all modules in the source description. This means that the path delays specified in the specify

blocks for delays from the module input to the module output will always be used as the pin-to-pin delay for the module input to output. For examples of path delays, see Chapter 13 on specify blocks in the Verilog LRM on-line help file.

- `+delay_mode_unit`: Command line argument sets all gate and specify block delays to one.
- `+delay_mode_zero`: Command line argument sets all gate and specify block delays to zero.
- `+includir+directory1+directory2...:` If SILOS III can not find a file name that is specified on the user's ``include` in the current directory, then SILOS III will search the directories specified by the `+includir` command line option for the file.
- `+ignore_sdf_interconnect_delay`: specifies that SDF INTERCONNECT delays will not be used. This can be useful for reducing the runtime and memory usage for fault simulation.
- `+ignore_sdf_port_delay`: specifies that SDF PORT delays will not be used. This can be useful for reducing the runtime and memory usage for fault simulation.
- `+mindelays`: This option selects the minimum delay specification for delays (min:typ:max).
- `+typdelays`: This option selects the typical delay specification for delays (min:typ:max). (Default: `+typdelays`)
- `+maxdelays`: This option selects the maximum delay specification for delays (min:typ:max).
- `+nodisplay`: This option suppresses all messages from `$display`, `$write`, etc. system tasks to standard output. This can be used to prevent these messages from cluttering the log file during logic simulation.
- `+nolibfaults`: Automatically inserts ``suppress_faults` and ``enable_portfaults`, and ``nosuppress_faults` and ``disable_portfaults` around every module in a library file. The library file can be specified using the `-y` and `-v` command line options, the `!library` command, or the "Project Files" dialog box.
- `+no_pulse_msg`: The command line option `"+no_pulse_msg"` turns off the `+pulse` messages. This does the same thing as the `"+pulse_quiet"` command line option.
- `+notimingchecks`: This option disables all timing checks, improving speed and reducing memory used.
- `+no_tchk_msg`: This option suppresses timing check violation messages. Timing checks are still processed, but no messages are printed to standard output if there is a timing check violation.
- `+nowarntfmpc`: This option suppresses the warning message for a mismatch in the number of port connections.
- `+plusargs`: You can enter "+" command-line arguments that are project specific, such `"+compare"`, `"+sdf"`, etc. For example, suppose you wanted to specify the SDF file only when you entered `"+sdf"` in the "plusargs" box for the Project Settings dialog box. Then your test bench may look like:

```

module test_bench;initial
    if ( $test$plusargs( "sdf" ))
        $sdf_annotate("test.sdf");// only execute if "+sdf" is an
argument
endmodule

```

- `+pulse_r/<n>` and `+pulse_e/<n>` command line arguments specify a range of pulse widths that will propagate to the path destination. For `+pulse_r/<n>`, "n" specifies a number in the range 0-100. This will reject any pulse whose width is less than "n" percent of the module path delay. For `+pulse_e/<n>`, "n" specifies a number in the range 0-100. This will flag as an error and drive unknown ("x") any path pulse whose width is less than "n" percent of the module path delay, but whose width is greater than `pulse_r`. For more information, see `PATHPULSE$` in the IEEE 1364 Verilog HDL manual.
- `+pulse_quiet` command line argument suppresses warning messages generated by `pulse_e` command line argument.
- `+suppressredef`: This option will suppress the warning message for redefinition of ``define` macros.
- `+suppressfloat`: This option will suppress the warning message for floating nodes, which may be caused by a gate input not having a driver, or by declaring a variable as a wire and then never assigning a value to it.
- `+timing_checks`: This option turns on all timing checks for fault simulation. This will slow down the fault simulation and increase the memory used by fault simulation.
- `+xl_order`: Specifies a switch so that the order of evaluation for always blocks is the same order as for Verilog-XL. This switch may be useful for obtaining the same simulation results as Verilog-XL. This option must be parsed before any modules are parsed. This option automatically enters "``define xl_order 1`". An example would be the order of evaluation for:

```

always @posedge clock ....
always @posedge clock ....

```

SILOS III also supports the following SILOS command-line option:

- `-nospec`

The `-nospec` command-line option eliminates all `specify` blocks. Eliminating the `specify` blocks will reduce the memory used and increase the simulation speed. However, eliminating the `specify` block delays may cause race conditions and non-convergence due to zero delays. If this happens, the rise and fall delays for all gates (whose delays are not explicitly specified) can be set to "1" with the following SILOS III command:

- `-"!delay .default =1,1"`

SILOS III also allows system commands to be entered from the command line, i.e. `-"!system \\"ls -lt\""`

For library searching, SILOS III also supports the ``uselib` compiler directive. The format for ``uselib` is:

```
`uselib file=filename dir=directory_name
```

where:

- `filename` is the full path name for a file containing one or more module definitions that are searched to complete unresolved instantiations.
- `directory_name` is the full path name for a directory of files whose names are a concatenation of the name of a module definition and a file extension, such as "dff.v".

Some examples of ``uselib` are:

The below example uses ``define` to specify macros for the ``uselib`. This makes it easier to change the library paths.

```
`define asic1 dir=c:\actel\lib\vlog libext=.v
`define asic2 file=d:\library\udp.v
`uselib `asic1 `asic2
```

The below example uses specifies the same ``uselib` without using a ``define`. Notice that the "libext" keyword for the library file name extensions is required when specifying a directory "dir" specification for a directory of library files.

```
`uselib file=\test\lib\udp.v dir=\test\lib2 libext=.v
```

B.2.2.28.3 Windows Batch Execution

SILOS III can be run as a batch execution from the Windows 95, Windows 98, and Windows NT, operating systems.

The command-line syntax for running SILOS III as a batch execution on the Windows 95, Windows 98, and Windows NT operating system is:

```
silos.exe -options +plusargs filename1 ... filenamen -
!command1 ... -!commandn
```

where:

"silos.exe" is the path to the "silos.exe" executable on Windows.

"-options" is one or more Verilog HDL style command-line options. An example of using command line options would be:

```
silos.exe -v exam1.udp -v exam1.lib -y library +libext+.v
exam1.v exam1.tst
```

For the above example, SILOS III will scan library files exam1.udp and exam1.lib and the ".v" files in directory library, and then input files exam1.v and exam1.tst. Then SILOS III

will automatically simulate the circuit, report any errors, and exit when there are no further commands to be executed from the command line or from a file (the "sim", "error", and "exit" commands do not have to be specified).

The above examples could also have used the "-f" command-line option to specify the file that has the command-line options. For example:

```
silos.exe -f design.vc
```

File "design.vc" would then contain the following commands and file names for the above example:

```
-v exam1.udp
-v exam1.lib
-y library
+libext_.v
exam1.v
exam1.tst
```

"plusargs" is one or more "+" arguments for the \$testplusargs system task in Verilog HDL.

"filename₁ ... filename_n" is the name of one or more input files for SILOS III. The files can contain Verilog HDL at the behavioral, gate, and switch levels. The files can also contain SILOS III commands. Any SILOS III commands in the files will be executed as they are encountered.

"!command₁ ... !command_n" is one or more optional SILOS III commands. For information on how to use SILOS III commands in a file, which may be simpler than from the command line. The "!" is required for all SILOS III commands that are on the command line. There must be no whitespace between the "!" and the SILOS III command. SILOS III commands that contain an embedded space must be enclosed by quotes, such as:

```
-"!bat exam1.log"
```

B.2.2.28.4 Unix Batch Execution

SILOS III can be run as a batch execution from the Unix operating system.

The command-line syntax for running SILOS III as a batch execution on the Unix operating system is:

```
silos -options +plusargs filename1 ... filenamen -\!command1
... -\!commandn
```

where:

Extensions

"silos" is the path to the "silos" executable on Unix. If you are running from a directory other than the installation directory you can set a link to silos on Unix:

```
ln -s installation_path/silos
```

"-options" is one or more command-line options supported by SILOS III (for more information). An example of using command line options would be:

```
silos -v exam1.udp -v exam1.lib -y library +libext+.v
exam1.v exam1.tst
```

For the above example, SILOS III will scan library files exam1.udp and exam1.lib and the ".v" files in directory library, and then input files exam1.v and exam1.tst. Then SILOS III will automatically simulate the circuit, report any errors, and exit when there are no further commands to be executed from the command line or from a file (the "sim", "error", and "exit" commands do not have to be specified).

"plusargs" is one or more "+" arguments for the \$testplusargs system task in Verilog HDL.

"filename₁ ... filename_n" is the name of one or more input files for SILOS III. The files can contain Verilog HDL at the behavioral, gate, and switch levels. The files can also contain SILOS III commands. Any SILOS III commands in the files will be executed as they are encountered.

"!\command₁ ... !\command_n" is one or more optional SILOS III commands. For information on how to use SILOS III commands in a file, which may be simpler than from the command line. The "\!" is required for all SILOS III commands that are on the command line, however, the "!" has a special meaning on UNIX and must be escaped as "\!". There must be no whitespace between the "!" and the SILOS III command. SILOS III commands that contain an embedded space must be enclosed by quotes, such as:

```
-\!batch exam1.log"
```

In Unix, there is an additional method for running SILOS III in the batch mode that is similar to the interactive mode. To setup a batch session, edit a file and enter the same SILOS III commands as you would have used for an interactive session. Next, submit the file as a batch run on your computer. The following file would run SILOS III as a batch session on a UNIX operating system using "C" shell:

```
#!/bin/csh
silos << mark
  batch exam1.log // redirects standard output to file "exam1.log"
  library exam1.lib exam1.udp library{.v}
  input exam1.v exam1.tst
  sim
  disk run01.out
  store probe q[4:1]
```

```

    exit
mark

```

B.2.3 Verilog Libraries

B.2.3.1 Overview

Simucad provides many of the popular TTL library models for the SN74LS series. The behavioral source for these parts is provided as four libraries:

- SN74LS series without timing (subdirectory "library\sn74ls").
- SN74LS series with timing (subdirectory "library\sn74lst").
- SN74BCT series without timing (subdirectory "library\sn74bct").
- SN74BCT series with timing (subdirectory "library\sn74bctt").

B.2.3.2 Library Command

SILOS III will search library files when module definitions are not found for the module instances in the design. The LIBRARY command can be used to specify library file names and file name extensions for library files.

To specify the library file names, enter:

```
LIBRARY      [filename]      [ { .ext } ]
```

| | |
|-----------------|--------------------------------------------------------------------------|
| LIBRARY | Defines disk file names for external libraries. |
| filename | Represents the name of one or more additional library disk files. |
| {.ext} | Represents the file name extension. |

When searching a directory for library files, SILOS III searches for a file whose root name is the same as the module name on the module instance, and whose extension matches the extension specified for the library search.

Application Notes:

1. Library files can contain module definitions and module instances, and macro definitions and macro expansions. Commands are not allowed in library files other than the BUS and INIT commands (for SILOS netlists).
2. LIBRARY files are useful for:
 - A method of inputting library parts with specific timing;
 - Reducing memory by not loading unreferenced netlist data;
 - Encrypting data (see “B.2.2.4 Encrypting Library Files”).
3. The search order for a module definition or macro definition is:
 - Files entered by the INPUT command or 'include compiler directive.
 - Library file names, or directories that contain library files ending with a specified extension, that were specified by the LIBRARY command. The library files will be searched in the order specified to the program.
4. Each LIBRARY command will override any previous LIBRARY commands (they are not cumulative). A LIBRARY command can use more than one line by beginning each new line with a "+" sign in column one (see the Examples below). If the file name specified by the LIBRARY command cannot be found during the CHECK command, a warning message is issued. Entering the LIBRARY command after preprocessing (PREPROC command) has no meaning and a warning message is not issued.
5. Library files can be encrypted by the CHGLIB program. Once a file has been encrypted, it cannot be entered with the INPUT command or 'include compiler directive. It is good practice to check the files for errors with the INPUT command before encrypting them.
6. Library files can be converted to random-access files by the CHGLIB program. Once a file has been converted to random-access, it cannot be entered with the INPUT command or 'include compiler directive. It is good practice to check the files for errors with the INPUT command before converting them to random-access.

Examples:

```
.LIBRARY d:\test\asic{.v}
!lib fast.lib
+ nmos.lib
+ ecl.dat
TTL - LS
```

B.2.3.3 TTL LS Parts List

The list below shows the TTL LS library parts provided with SILOS III. The behavioral source for these parts is provided with unit delays and with full timing:

(Ref. TTL Logic Data book, SDLD001A Revised March 1988)

(Ref. BiCMOS Bus Interface Logic Data book, SCBD001A Revised July 1989)

| Name | Description |
|-------------|--------------------------|
| 74LS00 | 2 INPUT NAND |
| 74LS01 | 2 INPUT NAND OC |
| 74LS02 | 2INPUT NOR |
| 74LS03 | 2 INPUT NAND OC |
| 74LS04 | HEX INVERTER |
| 74LS05 | HEX INVERTER |
| 74LS08 | 2 INPUT AND |
| 74LS09 | 2 INPUT AND OC |
| 74LS10 | 3INPUT NAND |
| 74LS11 | 3 INPUT AND |
| 74LS12 | 3 INPUT HAND OC |
| 74LS13 | 4 INPUT NAND SCHM. TRIG. |
| 74LS14 | HEX SCHM. TRIG. INVERTER |
| 74LS15 | 3 INPUT AND OC |
| 74LS19A | HEX SCHM. TRIG INVERTER |
| 74LS20 | 4 INPUT NAND |
| 74SL21 | 4 INPUT AND |
| 74LS22 | 4 INPUT NAND OC |
| 74LS24A | 2 INPUT NAND SCHM. TRIG. |
| 74LS26 | 2 INPUT NAND OC |
| 74LS27 | 3 INPUT NOR |
| 74LS28 | 2 INPUT NOR |
| 74LS30 | 8 INPUT NAND |
| 74LS31 | DELAY LINE |
| 74LS32 | 2 INPUT OR |

Extensions

| Name | Description |
|---------|------------------------|
| 74LS33 | 2 INPUT NOR OC |
| 74LS37 | 2 INPUT NAND |
| 74LS38 | 2 INPUT NAND OC |
| 74LS40 | 4 INPUT NAND |
| 74LS42 | BCD TO DECIMAL DECODER |
| 74LS51 | 3 WIDE AND-OR-INV |
| 74LS54 | 4 WIDE AND-OR-INV |
| 74LS55 | 2 WIDE AND-OR-INV |
| 74LS56 | FREQUENCY DIVIDER 50:1 |
| 74LS57 | FREQUENCY DIVIDER 60:1 |
| 74LS68 | DECADE/BINARY COUNTER |
| 74LS69 | DECADE/BINARY COUNTER |
| 74LS73A | JK FLIP-FLOP |
| 74LS74A | D FLIP-FLOP |
| 74LS75 | LATCH |
| 74LS76A | JK FLIP-FLOP |
| 74LS77 | LATCH |
| 74LS78A | JK FLIP-FLOP |
| 74LS83A | ADDER |
| 74LS85 | COMPARATOR |
| 74LS86A | 2 INPUT XOR |
| 74LS90 | DECADE COUNTER |
| 74LS91 | 8 BIT SHIFT REGISTER |
| 74LS92 | DIVIDE BY 12 COUNTER |
| 74LS93 | 4 BIT BINARY COUNTER |
| 74LS95 | 4 BIT SHIFT REG |

| Name | Description |
|-------------|--------------------------|
| 74LS96 | 5 BIT SHIFT REG. |
| 74LS107A | JK FLIP-FLOP |
| 74LS109A | JK FLIP-FLOP |
| 74LS112A | JK FLIP-FLOP |
| 74LS113A | JK FLIP-FLOP |
| 74LS114A | JK FLIP-FLOP |
| 74LS122 | MONOSTABLE MULTIVIBRATOR |
| 74LS123 | MONOSTABLE MULTIVIBRATOR |
| 74LS125A | TRI-STATE BUFFERS |
| 74LS126A | TRI-STATE BUFFERS |
| 74LS132 | 2 INPUT NAND SCHM. TRIG. |
| 74LS136 | 2 INPUT XOR OC |
| 74LS137 | 3 TO 8 DECODER |
| 74LS138 | 3 TO 8 DECODER |
| 74LS139A | 2 TO 4 DECODER |
| 74LS147 | PRIORITY ENCODER |
| 74LS148 | PRIORITY ENCODER |
| 74LS151 | MUX 8 TO 1 |
| 74LS153 | MUX 4 TO 1 |
| 74LS155A | 2 TO 4 DECODER |
| 74LS156 | 2 TO 4 DECODER OC |
| 74LS157 | 2 TO 1 MUX |
| 74LS158 | 2 TO 1 MUX |
| 74LS160A | SYNC 4-BIT COUNTER |
| 74LS161A | SYNC 4-BIT COUNTER |
| 74LS162A | SYNC 4-BIT COUNTER |

| Name | Description |
|----------|------------------------------|
| 74LS163A | SYNC 4-BIT COUNTER |
| 74LS164 | 8 BIT SHIFT REG. |
| 74LS165A | PARALLEL LOAD BIT SHIFT REG. |
| 74LS166A | PARALLEL LOAD BIT SHIFT REG. |
| 74LS169B | UP/DOWN BINARY COUNTER |
| 74LS170 | 4*4 REGISTER FILE OC |
| 74LS171 | D FLIP-FLOP |
| 74LS173A | D FLIP-FLOP WITH 3-STATE |
| 74LS174 | D FLIP-FLOP |
| 74LS175 | D FLIP-FLOP |
| 74LS181 | ALU |
| 74LS183 | CARRY SAVE ADDER |
| 74LS190 | UP/DOWN COUNTER |
| 74LS191 | UP/DOWN COUNTER |
| 74LS192 | UP/DOWN COUNTER |
| 74LS193 | UP/DOWN COUNTER |
| 74LS194A | 4 BIT SHIFT REGISTER |
| 74LS195 | 4 BIT SHIFT REGISTER |
| 74LS196 | BINARY COUNTER |
| 74LS197 | BINARY COUNTER |
| 74LS221 | MONOSTABLE MULTIVIBRATOR |
| 74LS240 | TRI-STATE BUFFERS |
| 74LS241 | TRI-STATE BUFFERS |
| 74LS242 | TRANSCEIVER |
| 74LS243 | TRANSCEIVER |

| Name | Description |
|-------------|--------------------------|
| 74LS244 | TRI-STATE BUFFERS |
| 74LS245 | TRANSCEIVER |
| 74LS251 | 3-STATE MUX |
| 74LS253 | 3-STATE MUX |
| 74LS257B | MUX |
| 74LS258B | MUX |
| 74LS259B | LATCH |
| 74LS261 | MULTIPLIER |
| 74LS266 | XNOR OC |
| 74LS273 | D FLIP-FLOPS |
| 74LS279 | SR LATCH |
| 74LS279A | SR LATCH |
| 74LS280 | PARITY GENERATOR/CHECKER |
| 74LS283 | 4 BIT ADDER |
| 74LS290 | DECADE COUNTER |
| 74LS292 | PROGRAMMABLE COUNTER |
| 74LS293 | BINARY COUNTER |
| 74LS294 | PROGRAMMABLE COUNTER |
| 74LS295B | SHIFT REG. |
| 74LS298 | MUX WITH STORAGE |
| 74LS299 | 8 BIT SHIFT REGISTER |
| 74LS322A | 8 BIT SHIFT REG. |
| 74LS323 | 8 BIT SHIFT REG. |
| 74LS348 | PRIORITY ENCODER |
| 74LS352 | MUX |
| 74LS353 | MUX |

Extensions

| Name | Description |
|-------------|--------------------------|
| 74LS354 | MUX |
| 74LS355 | MUX |
| 74LS356 | MUX |
| 74LS365A | BUS DRIVER |
| 74LS366A | BUS DRIVER |
| 74LS367A | BUS DRIVER |
| 74LS368A | BUS DRIVER |
| 74LS373 | LATCH |
| 74LS374 | FLIP-FLOPS |
| 74LS375 | LATCH |
| 74LS377 | D FLIP-FLOPS |
| 74LS378 | D FLIP-FLOPS |
| 74LS379 | D FLIP-FLOPS |
| 74LS381A | ALU |
| 74LS382A | ALU |
| 74LS384 | MULTIPLIER |
| 74LS385 | ADDER/SUBTRACTOR |
| 74LS386A | XOR |
| 74LS390 | DECADE COUNTER |
| 74LS393 | BINARY COUNTER |
| 74LS395A | SHIFT REG |
| 74LS396 | FLIP-FLOPS |
| 74LS399 | MUX WITH STORAGE |
| 74LS422 | MONOSTABLE MULTIVIBRATOR |
| 74LS440 | TRANSCEIVER |
| 74LS441 | TRANSCEIVER |

| Name | Description |
|-------------|--------------------|
| 74LS442 | TRANSCEIVER |
| 74LS444 | TRANSCEIVER |
| 74LS446 | TRANSCEIVER |
| 74LS449 | TRANSCEIVER |
| 74LS465 | BUFFER |
| 74LS466 | BUFFER |
| 74LS467 | BUFFER |
| 74LS468 | BUFFER |
| 74LS490 | DECADE COUNTER |
| 74LS540 | BUFFER |
| 74LS541 | BUFFER |
| 74LS590 | BINARY COUNTER |
| 74LS591 | BINARY COUNTER |
| 74LS592 | BINARY COUNTER |
| 74LS593 | BINARY COUNTER |
| 74LS594 | SHIFT REG. |
| 74LS595 | SHIFT REG. |
| 74LS596 | SHIFT REG. |
| 74LS597 | SHIFT REG. |
| 74LS598 | SHIFT REG. |
| 74LS599 | SHIFT REG. |
| 74LS604 | LATCH |
| 74LS606 | LATCH |
| 74LS607 | LATCH |
| 74LS620 | TRANSCEIVER |
| 74LS621 | TRANSCEIVER |

Extensions

| Name | Description |
|-------------|-----------------------|
| 74LS623 | TRANSCEIVER |
| 74LS639 | TRANSCEIVER |
| 74LS640 | TRANSCEIVER |
| 74LS641 | TRANSCEIVER |
| 74LS642 | TRANSCEIVER |
| 74LS644 | TRANSCEIVER |
| 74LS645 | TRANSCEIVER |
| 74LS646 | TRANSCEIVER/REGISTERS |
| 74LS647 | TRANSCEIVER/REGISTERS |
| 74LS648 | TRANSCEIVER/REGISTERS |
| 74LS649 | TRANSCEIVER/REGISTERS |
| 74LS651 | TRANSCEIVER/REGISTERS |
| 74LS652 | TRANSCEIVER/REGISTERS |
| 74LS653 | TRANSCEIVER/REGISTERS |
| 74LS668 | UP/DOWN COUNTER |
| 74LS669 | UP/DOWN COUNTER |
| 74LS671 | SHIFT REG. |
| 74LS672 | SHIFT REG. |
| 74LS673 | SHIFT REG. |
| 74LS674 | SHIFT REG. |
| 74LS681 | ALU |
| 74LS682 | COMPARATOR |
| 74LS684 | COMPARATOR |
| 74LS685 | COMPARATOR |
| 74LS686 | COMPARATOR |
| 74LS687 | COMPARATOR |

| Name | Description |
|---------|-------------|
| 74LS688 | COMPARATOR |
| 74LS690 | COUNTER |
| 74LS691 | COUNTER |
| 74LS693 | COUNTER |
| 74LS696 | COUNTER |
| 74LS697 | COUNTER |
| 74LS699 | COUNTER |

B.2.3.4 TTL BCT Parts List

Simucad provides many of the popular TTL library models for the 74 BCT series. The behavioral source for these parts is provided as two libraries:

- SN74BCT series without timing (subdirectory "library\sn74bct").
- SN74BCT series with timing (subdirectory "library\sn74bctt").

The list below shows the TTL BCT library parts provided with SILOS III:

(Ref. TTL Logic Data book, SDL001A Revised March 1988)

(Ref. BiCMOS Bus Interface Logic Data book, SCBD001A Revised July 1989)

| Name | Description |
|----------|-----------------------------|
| 74BCT125 | Quad Buffer Gates |
| 74BCT126 | Quad Buffer Gates |
| 74BCT240 | Octal buffers, line drivers |
| 74BCT241 | Octal buffers, line drivers |
| 74BCT244 | Octal buffers, line drivers |
| 74BCT245 | Octal bus transceivers |
| 74BCT373 | Octal D-type latches |
| 74BCT374 | Octal D-type FFs |

| Name | Description |
|-------------|-------------------------------|
| 74BCT540 | Octal buffers, line drivers |
| 74BCT541 | Octal buffers, line drivers |
| 74BCT543 | Octal registered transceivers |
| 74BCT534 | Octal D-type FFs |
| 74BCT620A | Octal bus transceivers |
| 74BCT623 | Octal bus transceivers |
| 74BCT640 | Octal bus transceivers |
| 74BCT652 | Octal bus transceivers |
| 74BCT760 | Octal buffers, line drivers |
| 74BCT2240 | Octal buffers, line drivers |
| 74BCT2241 | Octal buffers |
| 74BCT2244 | Octal buffers |
| 74BCT2827A | 10-bit bus/memory drivers |
| 74BCT2828A | 10-bit bus/memory drivers |
| 74BCT29827A | 10-bit buffers |
| 74BCT29828A | 10-bit buffers |
| 74BCT29833 | 8 to 9bit Parity Transceiver |
| 74BCT29834 | 8 to 9bit Parity Transceiver |
| 74BCT29843 | 9bit Bus Interface Xsciever |
| 74BCT29844 | 9bit Bus Interface Xsciever |
| 74BCT29845 | 8bit Bus Interface DLatches |
| 74BCT29846 | 8bit Bus Interface DLatches |
| 74BCT29853 | 8 to 9bit Parity Transceiver |
| 74BCT29854 | 8 to 9bit Parity Transceiver |
| 74BCT29861A | 10bit bus transceivers |

| Name | Description |
|-------------|------------------------|
| 74BCT29862A | 10bit bus transceivers |
| 74BCT29863A | 9bit bus transceivers |
| 74BCT29864A | 9bit bus transceivers |

The following are from Preliminary Data sheets. There is a total of 10 parts in 74BCT series which are not released products in the TI 1989 data book.

| Name | Description |
|-------------|-------------------------------|
| 74BCT544 | Octal registered transceivers |
| 74BCT756 | Octal buffers, line drivers |
| 74BCT8244 | SCAN Test with Octal Buffer |
| 74BCT8245 | SCAN Test & Octal Xscievers |
| 74BCT29821 | 10bit Bus Interface FF |
| 74BCT29822 | 10bit Bus Interface FF |
| 74BCT29823 | 9bit Bus Interface FF |
| 74BCT29824 | 9bit Bus Interface FF |
| 74BCT29841 | 10bit Bus - D Latches |
| 74BCT29842 | 10bit Bus - D Latches |

Appendix B.3

Silos III Menus

| | | |
|-------|-----------------------------------------|------|
| B.3.1 | Menus Overview | B3-1 |
| | B.3.1.1 Menu Bar | B3-1 |
| | B.3.1.2 Pop-up Menus | B3-2 |
| | B.3.1.3 Screen Conventions | B3-2 |
| B.3.2 | File Menu | B3-2 |
| | B.3.2.1 File/New | B3-2 |
| | B.3.2.2 File/Open | B3-3 |
| | B.3.2.3 File/Save | B3-3 |
| | B.3.2.4 File/Save As | B3-3 |
| | B.3.2.5 File/Print | B3-3 |
| | B.3.2.6 File/Print Preview | B3-4 |
| | B.3.2.7 File/Print Setup | B3-4 |
| | B.3.2.8 File/Exit | B3-5 |
| B.3.3 | Edit Menu | B3-5 |
| | B.3.3.1 Edit/Undo | B3-5 |
| | B.3.3.2 Edit/Cut | B3-5 |
| | B.3.3.3 Edit/Copy | B3-5 |
| | B.3.3.4 Edit/Paste | B3-6 |
| | B.3.3.5 Edit/Clear | B3-6 |
| | B.3.3.6 Edit/Select All | B3-6 |
| | B.3.3.7 Edit/Find | B3-6 |
| | B.3.3.8 Edit/Find Next | B3-6 |
| | B.3.3.9 Edit/Replace | B3-6 |
| | B.3.3.10 Edit/Goto Line | B3-7 |
| B.3.4 | View Menu | B3-7 |
| | B.3.4.1 View/Zoom | B3-7 |
| | B.3.4.1.1 Zoom-all | B3-7 |
| | B.3.4.1.2 Zoom-out | B3-7 |
| | B.3.4.1.3 Zoom-in | B3-7 |
| | B.3.4.1.4 Zoom-markers | B3-7 |
| | B.3.4.2 View/Main Toolbar | B3-7 |
| | B.3.4.3 View/Analyzer Toolbar | B3-8 |
| | B.3.4.4 View/Status Bar | B3-8 |
| B.3.5 | Project Menu | B3-9 |
| | B.3.5.1 Project/New | B3-9 |
| | B.3.5.2 Project/Open | B3-9 |

| | | |
|-----------|-------------------------------------------------------------|-------|
| B.3.5.3 | Project/Files | B3-10 |
| B.3.5.4 | Project/Save As | B3-10 |
| B.3.5.5 | Project/Close | B3-10 |
| B.3.5.6 | Project/Save Project State | B3-11 |
| B.3.5.7 | Project/Restore Project State | B3-11 |
| B.3.5.8 | Project/Project Settings | B3-11 |
| B.3.5.9 | Project/Filters | B3-13 |
| B.3.5.10 | Project/Load/Reload Input Files | B3-14 |
| B.3.5.11 | Project/Load and Go | B3-14 |
| B.3.6 | Reports Menu | B3-14 |
| B.3.6.1 | Reports/Activity | B3-14 |
| B.3.6.2 | Reports/Errors | B3-15 |
| B.3.6.3 | Reports/Fault | B3-16 |
| B.3.6.4 | Reports/Iteration | B3-16 |
| B.3.6.5 | Reports/Nonconvergence | B3-16 |
| B.3.6.5.1 | Nonconvergence For Gate Designs | B3-16 |
| B.3.6.5.2 | Nonconvergence (“Hanging”) for Behavioral Designs | B3-18 |
| B.3.6.6 | Reports/Size | B3-19 |
| B.3.7 | Explorer Menu | B3-19 |
| B.3.7.1 | Explorer/Open Explorer | B3-19 |
| B.3.7.2 | Explorer/Go to Module Source | B3-20 |
| B.3.8 | Debug Menu | B3-20 |
| B.3.8.1 | Debug/Go | B3-21 |
| B.3.8.1.1 | Simulation Suggestions | B3-21 |
| B.3.8.2 | Debug/Break Simulation | B3-22 |
| B.3.8.3 | Debug/Finish Current Timepoint | B3-22 |
| B.3.8.4 | Debug/Restart Simulation | B3-22 |
| B.3.8.5 | Debug/Step | B3-22 |
| B.3.8.6 | Debug/Breakpoints | B3-23 |
| B.3.9 | Options Menu | B3-24 |
| B.3.9.1 | Options/Fonts | B3-24 |
| B.3.9.2 | Options/Tabs | B3-24 |
| B.3.9.3 | Options/Snap to Edges | B3-24 |
| B.3.9.4 | Options/Title Tips | B3-25 |
| B.3.9.5 | Options/Analog Integer Display | B3-25 |
| B.3.9.6 | Options/Full Path Title | B3-25 |
| B.3.9.7 | Options/Data Tips | B3-25 |
| B.3.10 | Window Menu | B3-25 |
| B.3.10.1 | Window/Cascade | B3-26 |
| B.3.10.2 | Window/Tile | B3-26 |

| | | |
|------------|---------------------------------------------------|-------|
| B.3.10.3 | Window/Arrange Icons | B3-26 |
| B.3.10.4 | Window/Explorer | B3-26 |
| B.3.10.5 | Window/Watch | B3-26 |
| B.3.10.6 | Window/Data Analyzer | B3-26 |
| B.3.10.6.1 | Digital and Analog Signal Display | B3-27 |
| B.3.10.6.2 | Notes on using the Data Analyzer Window | B3-29 |
| B.3.11 | Help Menu | B3-31 |
| B.3.11.1 | Help/Contents | B3-31 |
| B.3.11.2 | Help/Using Help | B3-32 |
| B.3.11.3 | Help/SILOS III User's Manual | B3-32 |
| B.3.11.4 | Help/Verilog LRM | B3-32 |
| B.3.11.5 | Help/SDF Manual | B3-32 |
| B.3.11.6 | Help/About SSE | B3-32 |
| B.3.12 | Pop-up Menus | B3-32 |
| B.3.12.1 | Explorer Window | B3-33 |
| B.3.12.1.1 | Add Signals to Analyzer | B3-33 |
| B.3.12.1.2 | Name Filter | B3-33 |
| B.3.12.1.3 | Copy Scope | B3-35 |
| B.3.12.1.4 | Go to Module Source | B3-35 |
| B.3.12.1.5 | Go to Scope Menu Selection | B3-36 |
| B.3.12.1.6 | Properties. | B3-36 |
| B.3.12.2 | Watch Window | B3-37 |
| B.3.12.2.1 | Add Signal/Expression. | B3-37 |
| B.3.12.2.2 | Set Value For Watch Window | B3-37 |
| B.3.12.2.3 | Free Forced Wire For Watch Window | B3-37 |
| B.3.12.2.4 | Clear All For Watch Window | B3-37 |
| B.3.12.3 | Data Analyzer Pop-up Menus | B3-37 |
| B.3.12.3.1 | Data Analyzer Timeline Area | B3-37 |
| B.3.12.3.2 | Data Analyzer Signal List Box | B3-39 |
| B.3.12.4 | Source Window Pop-up Menus. | B3-43 |
| B.3.12.4.1 | Undo | B3-43 |
| B.3.12.4.2 | Cut | B3-43 |
| B.3.12.4.3 | Copy. | B3-43 |
| B.3.12.4.4 | Paste | B3-44 |
| B.3.12.4.5 | Add/Remove Breakpoint | B3-44 |
| B.3.12.4.6 | Data Tips | B3-44 |
| B.3.12.4.7 | Data Tip Radix | B3-44 |

Appendix B.3 Silos III Menus

B.3.1 Menus Overview

B.3.1.1 Menu Bar

The SILOS Simulation Environment (SSE) provides the following top-level menus:

- File menu
- Edit menu
- View menu
- Project menu
- Explorer menu
- Reports menu
- Debug menu
- Options menu
- Window menu
- Help menu.

The pull-down menus for the SSE change depending on which window has the focus (the window that is in focus has its title bar highlighted). For example, when the Data Analyzer window has the focus the available top-level menus are different from the SILOS III window.

Many of the menu selections can be accessed by clicking on buttons on the toolbar. To see a label for each button on the toolbar, place the mouse cursor over the button for a few seconds and an explanatory text message will appear.

B.3.1.2 Pop-up Menu

Many of the windows in SILOS III have a pop-up menu that can be accessed by right-clicking (for more information, see Pop-up Menus. For example, if you left-click in the left-hand side of the Explorer window, you will see the pop-up menu for the Explorer.

B.3.1.3 Screen Conventions

The following conventions should be noted for the screens:

- Clicking **OK** will close the screen and any active options or specifications will be used.
- Clicking **Cancel** will close the screen and not affect any options or specifications.
- Clicking **Close** button will close the screen, however, options selected for the screen are not canceled.
- Clicking **STOP** on the toolbar or pressing ESC will stop the current process, such as inputting a file or running logic simulation. If SILOS III “hangs” and does not respond, see Reports/Nonconvergence. For the command-line version (“silos.exe” on the PC and “silos” on Unix), pressing the CTRL and C keys will stop the current process.

B.3.2 File Menu

The File menu provides the following commands:

- File/New
- File/Open
- File/Save
- File/Save As
- File/Print
- File/Print Preview
- File/Print Setup
- File/Exit.

B.3.2.1 File/New

Opens a new source window for editing.

B.3.2.2 File/Open

Opens a source window for an existing file so that you can view or edit the file. More than one source window can be open at the same time. Use the **Window** menu to switch among the multiple open documents.

To simulate a project, use **Project/New** to create a new project.

B.3.2.3 File/Save

Saves the contents of the source file window that has the focus. The document remains open so you can continue working on it.

To save the simulation results for logic simulation, see Project/Save Project State

B.3.2.4 File/Save As

Allows you to specify a file name and then save the contents of the source file window that has the focus.

When you choose **Save As**, the document remains open so you can continue working on it.

To save a project to a different project name, see Project/Save As.

B.3.2.5 File/Print

Allows you to print the Output window, the source windows and the report windows.

The Data Analyzer waveforms use the Analyzer Print Options screen for print.

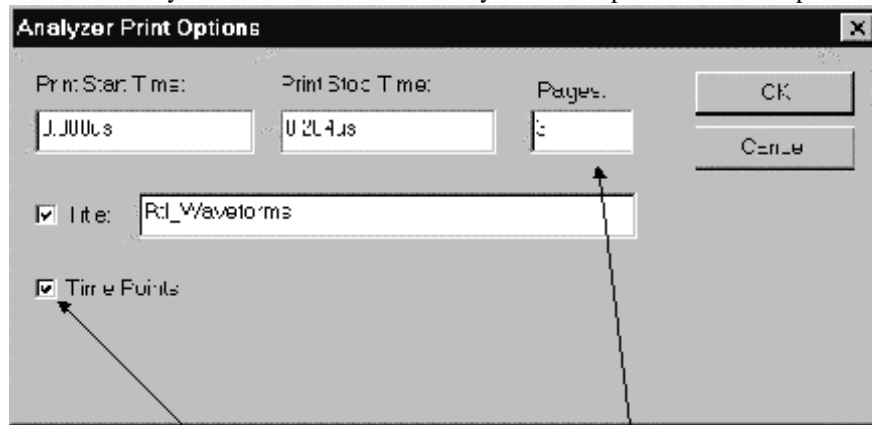

Selecting this will print the time values for the T1 and T2 timing markers and the delta time

The number of pages will automatically adjust to the print start and stop times.

The fonts for the Data Analyzer window can be set using **Options/Fonts**.

The Analyzer Print Options screen will print multiple pages of the waveform display. The number of pages to be printed is specified in the pages box. When printing multiple pages, the pages are automatically determined based on the **Print Start** and **Print Stop** times, and the number of pages specified.

B.3.2.6 File/Print Preview

Displays a preview of the printout for the Output window, the source windows, and the report windows.

B.3.2.7 File/Print Setup

Allows you to set up the printer for the Output window, the source windows, and the report windows.

B.3.2.8 File/Exit

Exits the SILOS Simulation Environment. When the SSE is exited the simulation history is lost unless **Project/Save Project State** is selected before exiting.

B.3.3 Edit Menu

The Edit menu provides the following commands:

- Edit/Undo
- Edit/Cut
- Edit/Copy
- Edit/Paste
- Edit/Clear
- Edit/Select All
- Edit/Find
- Edit/Find Next
- Edit/Replace
- Edit/Goto Line

B.3.3.1 Edit/Undo

Undoes your last editing or formatting action, including cut and paste actions. If an action cannot be undone, **Undo** appears dimmed on the **Edit** menu.

B.3.3.2 Edit/Cut

Deletes text from a document and places it onto the Clipboard, replacing the previous Clipboard contents.

B.3.3.3 Edit/Copy

Copies text from a document onto the Clipboard, leaving the original intact and replacing the previous Clipboard contents. When the Data Analyzer window has the focus, **Edit/Copy** copies the Data Analyzer window (signal names, scope, values, and waveforms) so it can be pasted into Microsoft Word.

B.3.3.4 Edit/Paste

Pastes a copy of the Clipboard contents at the insertion point, or replaces selected text in a document.

B.3.3.5 Edit/Clear

Deletes selected text from a document, but does not place the text onto the Clipboard.

Use **Clear** when you want to delete text from the current document but you have text on the Clipboard that you want to keep.

B.3.3.6 Edit/Select All

Selects all the text in a document at once.

You can copy the selected text onto the Clipboard, delete it, or perform other editing actions.

B.3.3.7 Edit/Find

Searches for characters or words in a document.

You can match uppercase and lowercase letters and search forward or backward from the insertion point.

B.3.3.8 Edit/Find Next

Repeats the last search without opening the Find screen.

B.3.3.9 Edit/Replace

Replaces one string with another.

B.3.3.10 Edit/Goto Line

Goes to the source line number that was specified.

B.3.4 View Menu

The View menu provides the following commands:

- View/Zoom
- View/Main Toolbar
- View/Status Bar

B.3.4.1 View/Zoom

The **View** menu has **Zoom** selections for the Data Analyzer window. A check mark appears next to the menu item that is used. These zoom selections are also buttons on the toolbar.

B.3.4.1.1 Zoom-all

Displays the entire simulation time range.

B.3.4.1.2 Zoom-out

Zooms out by a factor of two.

B.3.4.1.3 Zoom-in

Zooms in by a factor of two.

B.3.4.1.4 Zoom-markers

Zooms in between the T1 and T2 timing markers if they are displayed.

B.3.4.2 View/Main Toolbar

A check mark appears next to the Main toolbar when it is displayed.

Many of the selections for pull-down menus can also be accessed by clicking-on buttons on the Main toolbar. To obtain a text message of each button's function, place the mouse cursor over the button for a few seconds and an explanatory text message will appear.

The location of the Main toolbar can be changed by using the mouse to grab an edge of either toolbar and dragging the toolbar to the desired location.

B.3.4.3 View/Analyzer Toolbar

A check mark appears next to the Analyzer toolbar when it is displayed.

Many of the selections for pull-down menus and can also be accessed by clicking-on buttons on the Analyzer toolbar. To obtain a text message of each button's function, place the mouse cursor over the button for a few seconds and an explanatory text message will appear.

The location of the Analyzer toolbar can be changed by using the mouse to grab an edge of either toolbar and dragging the toolbar to the desired location.

B.3.4.4 View/Status Bar

Displays or hides the Status Bar at the bottom of the SSE.

The left area of the Status Bar describes actions of menu items as you use the arrow keys to navigate through menus. This area similarly shows messages that describe the actions of toolbar buttons as you depress them, before releasing them. If you wish not to execute the toolbar button after viewing the description of the toolbar button, then release the mouse button while the pointer is off the toolbar button.

The right area of the Status Bar displays the time values for the T1, T2, the delta time, and the current time. The farthest right area of the status bar displays which of the following keys are latched down:

| Indicator | Description |
|-----------|--------------------------------------|
| CAP | The Caps Lock key is latched down. |
| NUM | The Num Lock key is latched down. |
| SCRL | The Scroll Lock key is latched down. |

B.3.5 Project Menu

The Project menu provides the following commands:

- Project/New
- Project/Open
- Project/Files
- Project/Save As
- Project/Close
- Project/Save Project State
- Project/Restore Project State
- Project/Project Settings
- Project/Filters
- Project/Load/Reload Input Files
- Project/Load and Go.

B.3.5.1 Project/New

Opens the Create New Project screen, which enables you to specify the name and working directory for a new project. Projects provide a useful method for organizing your source files, as the files and libraries for the project may be scattered across many directories.

The new project name can be typed into the **File Name** box. The SSE will automatically append the suffix “.spj” to the project name if you do not add a suffix to the project name. Click **Save** to create the project name and exit the screen. Click **Cancel** to exit the screen without creating a project name.

After clicking **Save**, the Project Files screen is automatically opened. This screen enables you to specify all the source files, library files, and PLI library files associated with a project.

To create a new project that is similar to an existing project, you may want to use **Project/Save As** (see Project/Save As).

B.3.5.2 Project/Open

Opens the Open Project screen to specify the name for opening an existing project. Click **Open** to open the project. Click **Cancel** to exit the menu. Before opening a project the SSE is automatically reset so that the results from any previous project are lost.

B.3.5.3 Project/Files

Opens the Project Files screen for specifying the input files and library files for a project. To select a project for the Project Files screen use **Project/New** or **Project/Open**.

The **File Group** list box allows you to select Verilog HDL “Source Files”, “Library Files”, and “PLI Library Files”. To add source files, have the **Source Files** option selected in the **File Group** box. Next double-click on a file name in the list box, or highlight a file name in the list box and click **Add** to add the source file to the **Files in Group** list box. Files can be deleted from the project by highlighting the file name in the **Files in Group** box and clicking **Remove**. The **Move Up** and **Move Down** buttons allow you to rearrange the file names in the **Files in Group** list box. Click **Ok** to update the project and close the screen and **Cancel** to exit the screen without affecting the project.

To specify library files, click-on the drop-down arrow in the **File Group** list box in the Project Files screen, and select “Library Files”. Double-click on library file names in the list box to add them to the **Files in Group** list box. You can also select more than one library file by clicking on a file name to highlight it, and then hold down the SHIFT key or the CTRL key while clicking on additional file names. To specify a directory of library files whose file name extensions end in “.v”, enter the directory name followed by “{.v}” in the **File Name** box, and click **Add**. An example for specifying all the files ending with “.v” for directory “library” would be “library{.v}”. To specify PLI library files, click-on the drop-down arrow in the **File Group** list box in the Project Files screen, and select “PLI Library Files”. Double-click on PLI library file names in the list box to add them to the **Files in Group** list box as PLI library file names.

To actually input the files for a project, use **Project /Load/Reload Input Files** or the **Load/Reload Input Files** button on the toolbar.

B.3.5.4 Project/Save As

Saves the project to the project name that you specify. It does not save the simulation history for the Data Analyzer. The Save As feature can be used to easily clone projects for testing purposes without having to modify the original project.

B.3.5.5 Project/Close

Closes a project. All “child” processes such as the Output window and the Data Analyzer window are also closed.

B.3.5.6 Project/Save Project State

Saves the simulation results and the current state of the simulator to disk. This feature is very useful for preventing simulation data loss so that you do not have to re-simulate your design if you exit SILOS III or if SILOS III crashes. **Project/Save Project State** can be selected at any time after simulation has halted.

When SILOS III is restarted, the **Project/Restore Project State** can be used to reload the simulation up to the last time point that was saved. The Data Analyzer can then be used to view the simulation results and the simulation can be continued. The **Project/Restore Project State** must be selected immediately after SILOS III is reopened or a project is opened. The **Project/Restore Project State** menu can not be selected after selecting the Project/Load/Reload Input Files menu or the **Go** button.

The simulation history is stored on disk in the file named “project_name.sim”, and the simulation state is stored on disk in the file named “project_name.cmm”. The “project_name.cmm” file will be slightly larger than the size of you SILOS III simulation in RAM memory.

B.3.5.7 Project/Restore Project State

When SILOS III is restarted, **Project/Restore Project State** can be used to reload the simulation up to the last time point that was saved by **Project/Save Project State**. The Data Analyzer can then be used to view the simulation results and the simulation can be continued. **Project/Restore Project State** must be selected immediately after SILOS III is reopened or a project is opened. It can not be selected after selecting **Project/Load/Reload Input Files** or the **Go** button.

The simulation history is stored on disk in the file named “project_name.sim”, and the simulation state is stored on disk in the file named “project_name.cmm”. The “project_name.cmm” file will be slightly larger than the size of you SILOS III simulation in RAM memory.

B.3.5.8 Project/Project Settings

Allows you to set the command-line options and other options for SILOS III. For these settings to take effect, you must click on the **Load/Reload Input Files** button, or choose **Project/Load/Reload Input Files**.

Available options for the Project Settings screen are:

- Analyzer Symbol Table File: This specifies a file that substitutes text strings for state values for vectors displayed in the Data Analyzer. The text strings can be symbols for a state machine, making the state machine much easier to debug. For an example, see Displaying

Vectors Using Symbolic Names.

- Auto File Save: Enabling this feature will cause SILOS III to automatically save any source file you have modified whenever you click on the **Load/Reload Input Files** button on the Main toolbar, or choose **Project/Load/Reload Input Files**.
- Command Line Arguments: You can use Verilog style command line arguments for SILOS III. The command line arguments can be entered from the Command Line Arguments box in the Project Settings screen, or from the command line if you are running a batch simulation.
- ``define's`: You can enter ``define` statements that are project specific. These ``define` compiler directives will be used in addition to any ``define` compiler directives in the design. When entering the ``define`, use just the `<text_macro_name> <MACRO_TEXT>` part of the ``define` syntax. For example, for the Verilog compiler directive:

```
`define wordsize 8,
```

you would enter in the Project Settings screen:

```
wordsize 8
```

- Delay Selection: You can select the “min/typ/max” delay setting for all delays in the project.
- Disable floating node warnings: This feature disables the warning message that informs you that a wire is not driven by anything, i.e. a floating node.
- Enable Silos extensions: This feature enables extensions to the Verilog HDL language, such as assigning to wires in procedural code and global variables (see Verilog HDL Extensions).
- Enable log file: This feature causes standard output to be written to a log file when the SSE program is exited. The default log file name is the project name with the “.log” file extension. When this option is selected the SSE will write to both standard output and the log file.
- Functional simulation: This feature reduces the memory used and increases simulation speed by eliminating the specify blocks from logic simulation. To prevent nonconvergence problems, the unit delay mode is used for all modules.
- Max Sim File Size: You can select the maximum size on disk for the simulation history save file. This prevents SILOS III from crashing when all available disk space is used. SILOS III will return to the Ready: prompt when the simulation history save file reaches the limit. The “reset savfile” command can be entered in the Command window in the Main toolbar to reset the simulation history save file to a few bytes. The simulation can be continued and the simulation results that are after the “reset savfile” can be reviewed.
- plusargs: You can enter “+” command-line arguments that are project specific, such as “+compare”, “+sdf”, etc. For example, suppose you wanted to specify the SDF file only if you entered “+sdf” in the “plusargs” box for the Project Settings screen. Then your test bench may look like:

```
module test_bench;
```

```

initial
    if ( $test$plusargs( "sdf" ) )
        $sdf_annotate("test.sdf");// only execute if "+sdf" is an
        argument
    endmodule

```

- **Retain simulation data file:** This prevents the simulation history save file from being deleted from disk when the SSE is exited. The default is to delete the simulation history file when the SSE is exited. Checking this option is not recommended, as it has no use and may clutter up your disk with large save files.
- **Save all sim data:** This feature will save the simulation history for every variable. If “Save all sim data” is not enabled, then the only variables saved are those specified on each instance in the hierarchy by the **Properties** command in the Explorer pop-up menu.
- **Simulation Data File Path:** This specifies the directory where the simulation history file is stored. This enables you to use disk drives with more space or that are more convenient.
- **Save `celldefine data:** This feature determines if variables in `celldefine - `endcelldefine boundaries are saved. This feature is useful for excluding variables that are inside of library cells from the save file, thus reducing the size of the save file on disk. When using the Data Analyzer, if you see “No Saved Data” instead of a waveform, this may mean that the signal is inside of a `celldefine boundary. To correct this, enable the **Save `celldefine data** option and re-simulate.
- **Tabs:** This feature will set the spacing for tabs in the source file windows. This can be useful for customizing the tab spacing.
- **Use Alternate Behavioral Evaluation Order:** This instructs the simulator to evaluate selected behavioral code in a similar order of execution as used by other Verilog HDL simulators.

B.3.5.9 Project/Filters

Opens the File Filters screen for specifying file name filters for the Project Files screen (**Project/Files**). If you specify a file filter, then the default filters are hidden for the Project Files screen.

The name filtering for the Project Files screen uses the standard Windows style wildcard characters for file name expansion:

The asterisk character “ * “ is used to match any pattern, including null.

The question mark character “ ? “ is used to match any single character.

B.3.5.10 Project/Load/Reload Input Files

Automatically resets SILOS III and inputs the files specified for the project that is open.

Logic simulation is then run to time=0 and you can begin debugging your project by setting breakpoints, single stepping, etc. The Data Analyzer can be opened to display the results during simulation. Choosing the **Go** button on the toolbar will run logic simulation until a “\$stop” or “\$finish” is encountered in the design, or until you click the **STOP** button on the toolbar.

B.3.5.11 Project/Load and Go

Automatically resets Hyperfault, inputs the files specified for the project, and then runs logic simulation until a \$stop or a \$finish system task is encountered, or until you click the **STOP** button on the toolbar.

B.3.6 Reports Menu

The Reports menu provides the commands:

- Reports/Activity
- Reports/Errors
- Reports/Fault
- Reports/Iteration
- Reports/Nonconvergence
- Reports/Size.

B.3.6.1 Reports/Activity

Can be used to pre-grade the test vectors for fault simulation by reporting nodes that have no activity (level transitions) during a logic-simulation. The logic simulation is much faster to run than fault simulation. An ACTIVITY report can be very useful for developing input test patterns to detect circuit faults for fault simulation. The number of level transitions at a node indicates an input test pattern's effectiveness. Faults at nodes which make no level transitions can not be detected.

Reports/Activity can be used to generate the following report:

- An activity table that lists the node names of nodes that do not transition.
- An HDL Code Coverage table that lists the lines of each file that were not executed. This

can be used to find problems with the HDL code, or stimulus that is not exercising all of the HDL code.

- An activity summary that lists totals for the number of nodes at each level of activity count.
- An activity histogram that shows known and potential level transitions versus time.

For the activity table for the Activity report, you will see the following legend:

Legend for “TRANSITION COUNT” column:

| | |
|---------|----------------------------------------------------------|
| value | Number of definite transitions |
| (value) | Number of possible transitions |
| “H” | No definite transitions, node High at Min time specified |
| “L” | No definite transitions, node Low at Min time specified |

The legend is stating that a “value” is reported to the left of a node name. A “definite” transition is defined as a change from a Low to High level or High to Low level, even if it goes through an intermediate Unknown level. A “possible” transition is defined as a change from a High or Low level to the Unknown level or from the Unknown level back to a High or Low level. A “H” reported to the left of the node name, means the node never had a definite transition, and the node was High at the time specified as the minimum time for the time range for the report. The default minimum time is time=0. A “L” reported to the left of the node name, means the node never had a definite transition, and the node was Low at the time specified as the minimum time for the time range for the report.

For the Summary for the Activity report, the percentages are based on the nodes listed that are within the range specified for the Activity report. The default range is zero transitions for the maximum and minimum number of transitions. The default is zero because the purpose of the Activity report is to report nodes that did not toggle for fault simulation. If you want to set the maximum number of transitions to greater than zero so you can see how many times the nodes are toggling, see the Activity Report For Nodes.

B.3.6.2 Reports/Errors

Reports the errors that occurred during read-in, preprocessing or simulation. An error level of “1” indicates a warning. Error levels 2 through 5 will prevent simulation until the error has been corrected.

B.3.6.3 Reports/Fault

Reports the fault simulation results.

B.3.6.4 Reports/Iteration

Useful for finding order of evaluation problems and race conditions. This command displays every signal that has more than one iteration at a timepoint from time=0 to the current timepoint. To view a graphical display for iterations at a timepoint, see Reports/Iteration.

B.3.6.5 Reports/Nonconvergence

Generates a report of any nonconverged nodes and their oscillating states for the time point that nonconvergence occurred. **Reports/Nonconvergence** can only be used to debug nonconvergence in gate level designs. For behavioral level designs, this command will produce a report that states there is no data to report. To debug nonconvergence for behavioral designs see Nonconvergence (“Hanging”) for Behavioral Designs.

B.3.6.5.1 Nonconvergence For Gate Designs

Reports the following information:

- Names of the unresolved devices and nodes.
- The “type” of device and node as either a “.type” data keyword, “NODE” for a wired connection with at least one bi-directional device or “BUS” for a wired connection between two or more unidirectional enabled gates.
- The node state values for the nonconvergence time point. State values reported are preceded by a “...” to indicate possible previous states.

Nonconvergence only occurs when gate delays are zero. Zero delays can cause the circuit to oscillate at a single timepoint. As the circuit oscillates, the simulator must iterate over the circuit trying to resolve the circuit to a single set of values. When the iteration limit is exceeded, the circuit nonconverges. A simple example of a circuit that would cause nonconvergence is a ring of three inverters whose delays are set to zero. Zero-delays occur during logic simulation when either a zero delay, or no delay is specified for devices (the default delay for Verilog HDL gate devices is zero). Zero-delays also occur during logic initialization (LINIT command), which forces delays to be zero so that SILOS III can perform a steady-state, DC solution of the circuit at time=0.

Nonconvergence may be due either to circuit path length or problems with designs involving feedback. To eliminate oscillations caused by problems involving feedback, the circuit design

must be corrected. When nonconvergence is due to path length, increasing the iteration limit should enable the circuit to converge. In general, each node in a serial path length requires one iteration to propagate a signal. The iteration limit during simulation is specified by the “.CONTROL.MXITR” command. The iteration limit at time=0 is specified by the “.CONTROL .MXDCI” command. Arbitrarily increasing the iteration limits is not recommended as it may dramatically increase the execution time necessary to reach nonconvergence.

To debug a non-convergence due to a problem in the circuit design, you will need to use the NONCONV command to store the nonconvergence report (Reports/Nonconvergence). Many times an important clue in solving a nonconvergence is to know which signal started oscillating first. The “probe” command can be used to find out which signal started oscillating (see Probing Node States). Use following steps to debug your circuit:

1. In the Command window for the Main toolbar, enter the “disk” command to name an output file, such as:

```
disk    file1
```

2. In the Command window for the Main toolbar, enter the “nstore nonconv” command to store the nonconvergence report in file1.

3. Next edit file1 and copy and paste the net names from the nonconvergence report to another file (file2) that you have the probe command in, for example:

```
!probe iter time1 time_end net1,,net2,,net3
```

where time1 is the timepoint before the non-convergence and time_end is the nonconvergence timepoint. If the net names use the SILOS style “(“ to delimit hierarchy, then you will have to change the “(“ to “.”.

4. In the Command window for the Main toolbar, prompt input the file that has the !probe command:

```
input   file2
```

From the probe report, determine which net is oscillating first.

5. Open the Data Analyzer and the Explorer window. In the Explorer window, select the signal that was first oscillated and drag and drop it to the Data Analyzer. Then highlight the signal in the Data Analyzer and use **Trace Signal Inputs** to trace backwards from the net that started oscillating so that you can draw the circuit for that net and figure out the cause of the nonconvergence.

Reports/Nonconvergence only reports the basic options for the nonconvergence report. For additional options, such as the INPUT option that reports the states for all inputs of devices which drive the oscillating nodes, and the ITER=val option that specifies the iteration number to the 1st of eight states for each node reported for nonconvergence, see the Reports/Nonconvergence.

B.3.6.5.2 Nonconvergence (“Hanging”) for Behavioral Designs

When nonconvergence occurs in behavioral designs, SILOS III may be able to stop the simulation and report an error stating that there has been nonconvergence. For nonconvergence during behavioral simulation, **Reports/Nonconvergence** may produce a report that states there is no data to report. When this happens, you can click on the Step button on the Main toolbar and immediately begin to single step in the nonconverged source code.

Infinite loops in the user's behavioral code can cause SILOS III to “hang” and not respond. When the infinite loop occurs at time=0 SILOS III will “hang” and never get to the “Ready:” prompt. When the infinite loop occurs during simulation, SILOS III will hang and does not respond to the **STOP** button or the ESC key on the keyboard. Different techniques are used to debug “hangs” at time=0 and “hangs” during simulation.

When SILOS III hangs at time=0 and the Output window never displays the “Ready:” prompt, this is usually due to an error in the behavioral code in an initial or an always block. The below example hangs at time=0 due to the incorrect code “i = +1” which should be “i = i+1” in the below “for” loop:

```
module hang_at_0;
  reg a;
  integer I;
  initial for (i = 0; i < 10; i = +1)
    a = ~a;
endmodule
```

To debug a design that hangs at time=0, use comments “/* */” to comment out portions of the design until it no longer hangs at time=0. Then inspect the commented code and fix the problem in the behavioral code.

When SILOS III hangs during simulation the program will not respond to the STOP button or the Esc key on the keyboard. User errors in behavioral code are usually what cause SILOS III to “hang”. These errors are usually caused by a loop with no delay, such as in these code segments:

```
Code Segment 1:
for (i = a; b < c; i = i + 1) begin
  if (d & 9'h100) == 0) begin
    b = b + 1;
  end
end
```

```
Code Segment 2:
always @a
  b = ~b;
always @b
  a = ~a;
```

Code segment 1 hangs when the “if” test is not true, causing the “for” loop to infinitely loop at a time step. Code segment 2 hangs because each “always” block is triggering the other “always” block and neither “always” block has delay.

To debug a “hang” during simulation, run the simulation until it hangs, and then note the simulation time value on the status bar in the lower right-hand corner of SILOS III. Next kill SILOS III, restart SILOS III, and click the **Load/Reload Files**. When SILOS III stops at time=0, enter a simulation time to one less than when the simulation hangs in the Command window for the Main toolbar. Such as, if the simulation hangs at time=11251ns, enter “sim 11250ns” so that SILOS III stops just before it hangs. Then click the **Step** button. Keep single-stepping until you find the problem code.

If you single-step past the time point where the simulation was hanging, then the time value for the status bar had not yet been updated when SILOS III hung. To find the true time value that SILOS III hangs at, keep entering short simulation times at the “Ready:” prompt until the simulation hangs, such as enter “sim 10ns” or “sim 1ns” until the simulation hangs. Then restart SILOS III, re-simulate to just before the simulation hangs, and single-step until you find the problem.

B.3.6.6 Reports/Size

Reports the memory usage for SILOS III. A simpler method of obtaining the memory usage is to choose **Help/About SSE** to open the About SSE screen, which has the memory usage for SILOS III. The memory usage will increase during circuit read-in and preprocessing until simulation starts at time=0. After simulation starts the memory usage remains constant.

B.3.7 Explorer Menu

The Explorer menu provides the following commands:

- Explorer/Open Explorer
- Explorer/Go to Module Source

B.3.7.1 Explorer/Open Explorer

Opens a hierarchical Explorer window. The Explorer displays the name of every module instance and variable in the design in a tree structure similar to the directory structure for the Windows Explorer. The shift and control keys can be used to select variable names in a similar manner to the Windows Explorer. Names can then be dragged and dropped to the other windows, such as the Data Analyzer window and the Watch window. The Explorer window

also has pop-up menus that can be accessed by using the right mouse button (see Explorer Window. The Explorer is multi-threaded. This enables you to use the Explorer or even simulate while the Explorer is “working”.

The hierarchical Explorer window is divided into two vertical windows with the hierarchy of module instances and gates listed in the left window and the variable names listed in the right window. To traverse the hierarchy of the design in the left window, click-on the plus sign to the left of the instance, or double-click on module instances. As each module instance or gate is selected in the left window, the names of the variables in that instance are displayed in the right window. Symbols to the left of the variables distinguish port variables (the symbol is a pad) from variables local to the instance (the symbol is a box with an “X” for logic variables, “R” for real variables and “I” for integer variables). Input ports have the pad symbol pointing to the right, output ports have the pad symbol pointing to the left, and inout ports have the pad symbol pointing in both directions.

When you open the Explorer window, the first hierarchical name listed is the “global” module. The global module contains the names of any global variables (Verilog HDL Extensions. SILOS III also has global variables called “ExpectedValueError” for checking the results of expected values (for more information, see Expected Values and Stimulustable.

B.3.7.2 Explorer/Go to Module Source

Opens a source window that displays the source code for the hierarchical instance you selected in the left hand “Tree” side of the Explorer window. This enables you to quickly find the source code for a module instance when you have a large design that spans many files scattered across many directories.

B.3.8 Debug Menu

The Debug menu provides the following commands:

- Debug/Go
- Debug/Break Simulation
- Debug/Finish Current Timepoint
- Debug/Restart Simulation
- Debug/Step
- Debug/Breakpoints

B.3.8.1 Debug/Go

Performs logic simulation. The **Go** button is also available on the toolbar.

When **Go** is selected the files specified for the project are automatically input into SILOS III (unless they have already been input). Logic simulation is then run until a “\$stop” or “\$finish” is encountered in the design. During simulation, the **Go** button will change into a **Stop** button which can be clicked on to halt the simulation at any time.

The **Go** button can be useful during single stepping to skip across uninteresting source code to the next breakpoint, at which point the single stepping can be resumed.

B.3.8.1.1 Simulation Suggestions

Libraries

To increase the speed of processing your design, use the library feature to specify large library files from vendors. Any file of Verilog source code can be specified as a library file. To specify library files, see the File Menu.

SILOS III is very efficient in saving the simulation results to disk. In general, there is only a 10% to 15% difference in speed between the saving every variable in the hierarchy and saving nothing. However, if the save file on disk becomes large enough (over a few hundred megabytes) then the time spent writing to disk may be significant.

To reduce simulation save file size on disk, you can select which parts of the hierarchy that you want to save the simulation results for. To specify which instances to save information for during simulation, choose **Properties** from the pop-up menu for the left-hand side of the Explorer window (see Properties).

Restarting Simulation

SILOS III has the ability to restart the simulation from any timepoint by using the save and restore feature (see Project/Save Project State and Project/Restore Project State). Using this feature eliminates the time required to re-input and re-simulate the design. A debugging strategy may be to simulate to a timepoint, and then use **Project/Save Project State** to save the state of the simulation. You can then set variables to a value and continue simulation. To restart the simulation, exit SILOS III, then restart SILOS III, and choose **Project/Restore Project State** to return the simulation to the timepoint the simulation was saved at.

To restart the simulation from time=0, you do not need to exit SILOS III. Instead, use **Debug/Restart Simulation**. This is useful for re-starting single stepping without having to re-input the design.

Loss of Simulation Data

To prevent the loss of the simulation results due to unexpected interruptions, you can save the state of SILOS III after logic simulation. When simulation has completed, save the simulation results by choosing **Project/Save Project State**. Then open the Data Analyzer, review your simulation results, and debug your design. If you need to re-enter SILOS III, you can select **Project/Restore Project State**, open the Data Analyzer and view the waveforms without re-simulating.

B.3.8.2 Debug/Break Simulation

Stops the SILOS III program from simulating logic simulation. The ESC key or the **STOP** button on the toolbar performs the same function.

B.3.8.3 Debug/Finish Current Timepoint

Used to continue the simulation until the end of the current timepoint. This is useful to complete the time step during single-stepping so that the Data Analyzer waveforms are updated.

B.3.8.4 Debug/Restart Simulation

Restarts the SILOS III program from time zero. This is useful if you have reviewed the simulation results and want to rerun the simulation to set breakpoints or to force signals to a value.

B.3.8.5 Debug/Step

Single steps through the HDL source code for the project. As SILOS III single steps it places a “yellow arrow” to the left of the line.

Single stepping can be very useful when combined with breakpoints and the Watch window for debugging behavioral code. As you step through the HDL source code you can highlight variables and expressions and drag and drop them into the Data Analyzer window and the Watch window. The toolbar also has a **Step** button.

B.3.8.6 Debug/Breakpoints

Opens the Breakpoints screen for setting breakpoints. A typical method to debug a design using breakpoints would be to set a breakpoint in a module instance, then click on the **Go** button on the toolbar and simulate until the simulation stops in the module with the breakpoint. Next single step through the module to review how the source code is executing and watch variables change value in the Watch window and the Data Analyzer window. The **Go** button could then be used again to simulate until the simulation stops in the module and single-stepping is resumed.

There are four types of breakpoints:

Break at Simulation Time

Allows you to specify a simulation time and stops the logic simulation before the specified time is simulated. To specify a stop time, select “Break at Simulation Time” in the **Type** box and enter the stop time in the **Timepoint** box. Then click **Add**.

Break at Location

Stops logic simulation before the selected source line is simulated. To select a breakpoint location, you can use the **Toggle Breakpoint** button on the toolbar or you can use the Breakpoints screen. To use the **Toggle Breakpoint** button, first open a source file window by single-stepping with the SSE, or use **File/Open** or the **Open** button on the toolbar to open the source file window. Next, put the mouse cursor on an HDL source line you want to stop at. Then click the **Toggle Breakpoint** button on the toolbar to set the breakpoint. A red stop sign symbol will be placed to the left of the line next to the line number. You can also see that the breakpoint has been set in the Breakpoints screen.

Break in Module Instance

Allows you to select a module instance and then stop logic simulation each time a source line in the selected module instance is to be simulated. To select a breakpoint location, use the Explorer window to highlight the module instance you want to select. In the Breakpoints screen select “Break in Module Instance” for the **Type** box. The name of the module instance that you selected from the Explorer window will then appear in the **Scope** box. Next click **Add** to add the name of the module instance to the list of breakpoints.

The “Break in Module (Any Instance)” selection allows you to select a module instance and then stop logic simulation each time a source line in any instance of the module is to be simulated. To select a breakpoint location, use the Explorer window to highlight the module instance you want to select. In the Breakpoints screen select “Break in Module (Any Instance)” for the **Type** box. The name of the module instance that you selected from the Explorer window will then appear in the **Scope** box. Next click **Add** to add the name of the module instance to the list of breakpoints.

The **Add** button adds the specified breakpoint to the “Breakpoints” list. Active breakpoints are preceded by a plus (“+”) sign. Inactive breakpoints (**Disable** button) are preceded by a minus (“-”) sign. Individual breakpoints can be deleted with **Delete**. All breakpoints can be deleted by the **Clear All** button. The **OK** button closes the Breakpoints screen and saves the changes. The **Cancel** button closes the Breakpoints screen without saving the changes.

B.3.9 Options Menu

The Options menu provides the following commands:

- Options/Fonts
- Options/Tabs
- Options/Snap to Edges
- Options/Title Tips
- Options/Analog Integer Display
- Options/Full Path Title
- Options/Data Tips.

B.3.9.1 Options/Fonts

Opens the Fonts screen for setting the fonts for the Data Analyzer window and the source windows.

B.3.9.2 Options/Tabs

Opens the Tabs screen for setting the number of spaces in the Tab Interval for the source windows.

B.3.9.3 Options/Snap to Edges

When setting the T1 and T2 timing markers for the Data Analyzer, they will snap to the nearest edge if **Options/Snap to Edges** is active. When setting a timing marker, you can hold down the shift key to temporarily toggle the **Snap to Edges** selection to its opposite effect. Such as, if **Snap to Edges** is not selected, you can have the timing marker snap to the nearest edge when you set it by holding down the SHIFT key as you click-on the left or right mouse button with the mouse indicator (arrow) in the Waveform Display window.

B.3.9.4 Options/Title Tips

Enables the title tips for the signal names in the Data Analyzer. The title tips show the full hierarchical path name for a signal.

B.3.9.5 Options/Analog Integer Display

Integer variables can be displayed as a vector type of waveform or as an analog waveform. **Options/Analog Integer Display** sets the method of displaying integers.

B.3.9.6 Options/Full Path Title

Turns on and off the full directory path for a source file.

B.3.9.7 Options/Data Tips

The Data Tips feature for displaying the value, scope, radix, and simulation time point for a variable or expression in the source window can be toggled “on” or “off” with **Options/Data Tips**. Any variable or expression in a source window can be viewed by opening the source window and holding the mouse cursor over a variable or by highlighting an expression and holding the mouse cursor over the expression. This feature enables you to trace the cause of problems directly in a Verilog HDL source code window. **Open Module Source** can be used to quickly display the module definition for any instance in the hierarchy. This saves time opening the source window for displaying the value for variables and expressions when there are numerous files in the design.

B.3.10 Window Menu

The Window menu provides the following commands:

- Window/Cascade
- Window/Tile
- Window/Arrange Icons
- Window/Explorer
- Window/Watch
- Window/Data Analyzer.

B.3.10.1 Window/Cascade

Arranges multiple opened windows in an overlapped fashion.

B.3.10.2 Window/Tile

Arranges multiple opened windows in a non-overlapped fashion.

B.3.10.3 Window/Arrange Icons

Arranges icons for the minimized windows.

B.3.10.4 Window/Explorer

Opens the hierarchical Explorer window that displays the name of every module instance and variable in the design in a tree structure similar to the directory structure for the Windows Explorer (for more information, see “Explorer/Open Explorer”).

B.3.10.5 Window/Watch

Opens the Watch window that can be used to display the state value for specified variables and expressions as you single-step through the design. Variables or expressions can be dragged and dropped into the Watch window from any source file window, from the Explorer window, and from the Data Analyzer window. The Watch window also has a pop-up menu for setting and forcing variables to a value. The pop-up menu can be accessed by using the right mouse button.

B.3.10.6 Window/Data Analyzer

Opens the Data Analyzer window that can be used to display the waveforms for specified variables and expressions as you single-step through the design. Variables or expressions can be dragged and dropped into the Signal window for the Data Analyzer from any source file window and from the Explorer window.

The Data Analyzer window displays the logic simulation results as waveforms. The list box to the left of the waveforms shows the signal's "Name", its "Scope", and the "Value" of the signal at either the left axis of the waveform window or the T1 timing marker. The "Scope" represents the hierarchical path for the signal name. To copy the waveform display to Microsoft Word, choose **Edit/Copy** when the Data Analyzer window has the focus, and then paste it into Word.

Zoom Buttons Scan Buttons Pan Buttons For pop-up menu click in the gray area above the timeline with the right mouse button.

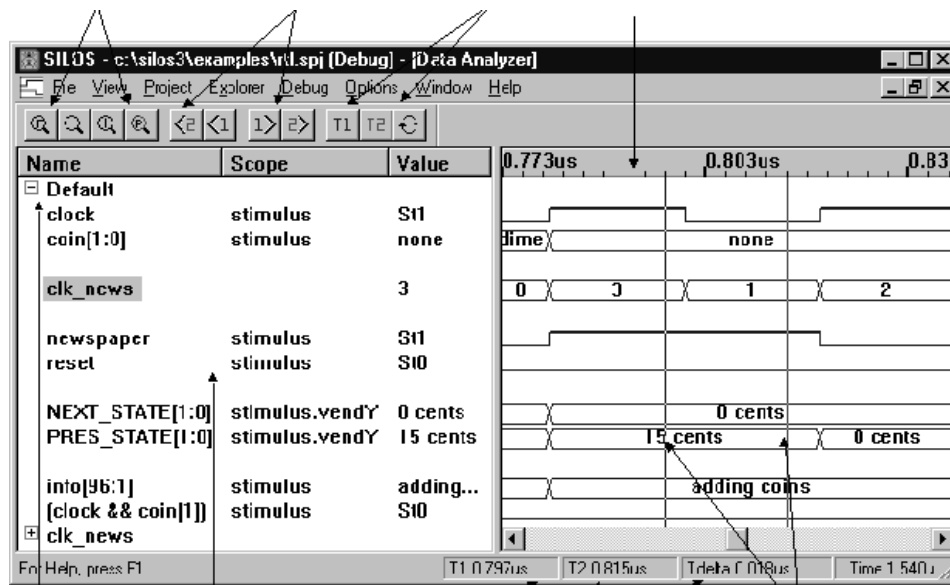

Default Display Group For pop-up menu, click in the Name list box with the right mouse button. Timing information shown in Status Bar. Holding cursor above the timeline also shows timing T1 and T2 Timing Markers

B.3.10.6.1 Digital and Analog Signal Display

Digital Signals

For digital signals, simulation results are displayed with waveforms denoting signal levels and colors denoting signal strength (on color monitors).

- Supply strength - black

Silos III Menus

- Strong strength - blue
- Pull strength - green
- High-Z, Unset, and Uncertain strength - red
- mixed strength for inserted groups and vectors - purple

Either the High level or Low level for the signal trace can be displayed as a thicker horizontal line. The default setting is for the High level to be a thicker line. To change this, add the following line in the “[Analyzer]” section for the sse.ini file in the Windows directory:

```
Hilite = Low
```

For group names that are inserted into other groups, vector names, and the name for real or integer variables, the value is displayed in the center of the waveform (resolution permitting). Double-clicking on an inserted group or vector name will show (or hide) the individual bits. Color is used to denote the strength for vector signals. Purple is used to represent a vector whose bits are at different strengths. If the timing markers have been set, then the vector value is provided at the top of the display along with the vector strength. If the bits for the vector are at different strengths, then “Mixed Strength” is displayed at the top of the display.

When the timing markers have been set, their value is shown in the status bar at the bottom of the Data Analyzer. If the bits are at different strengths then “Mixed Strength” is displayed for the timing marker value.

Analog signals

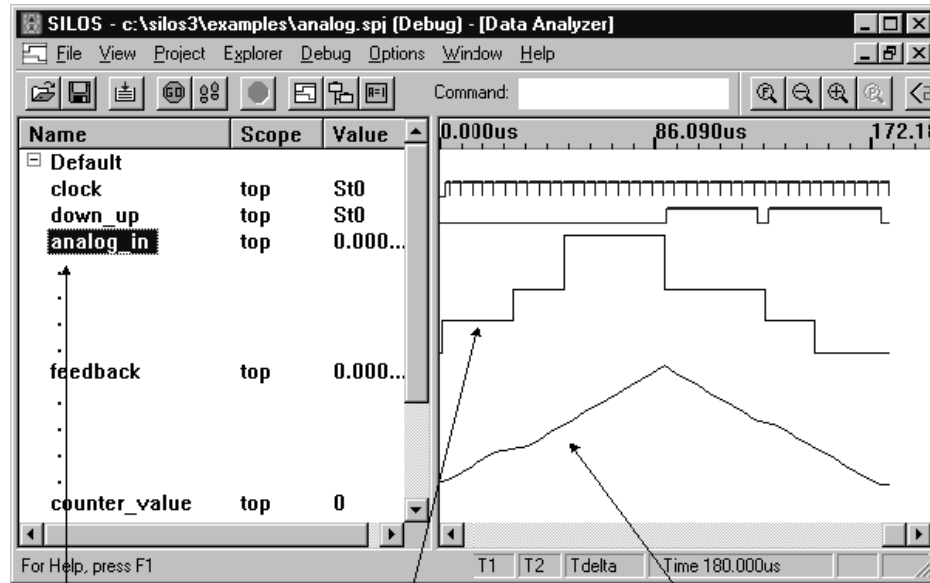

Double-click to toggle between stepping function and piece-wise linear.

Stepping function display on analog signal.

Piece-wise linear display of analog signal.

Analog signals for real variables are displayed as piece-wise linear or step waveforms. Double-clicking on the signal name will toggle between the two methods of displaying analog signals for real variables. If you want to change the default setting for displaying analog signals, add the following line in the “[Analyzer]” section for the sse.ini file in the Windows directory:

```
AnalogWaveMode=Step
```

or

```
AnalogWaveMode=Pwl
```

Integer variables can be displayed as a vector type of waveform or as an analog waveform. Choose **Options/Analog Integer Display** to set the method of displaying integers. Displaying integer variables as analog waveforms can be very useful for designing digital filters, etc.

B.3.10.6.2 Notes on using the Data Analyzer Window

Viewing More Waveforms

To create more space to display waveforms:

- Decrease the size of the **Name**, **Scope**, or **Value** buttons by grabbing and moving the vertical edge for the buttons.
- Increase the size of the Waveform Display by grabbing the vertical line that separates the **Name** list from the Waveform Display and moving the vertical line to the left or right.
- Use the **View** menu to hide the Status Bar or Tool bars.
- Grab the toolbars and move them to any part of your monitor display, even outside of the SILOS III program.

Multiple Data Analyzers

To open one or more Data Analyzer windows, you can use the **Open Analyzer** button on the toolbar. Each time the Analyzer is started, it can be used to simultaneously display another copy of the simulation results.

“No Saved Data”

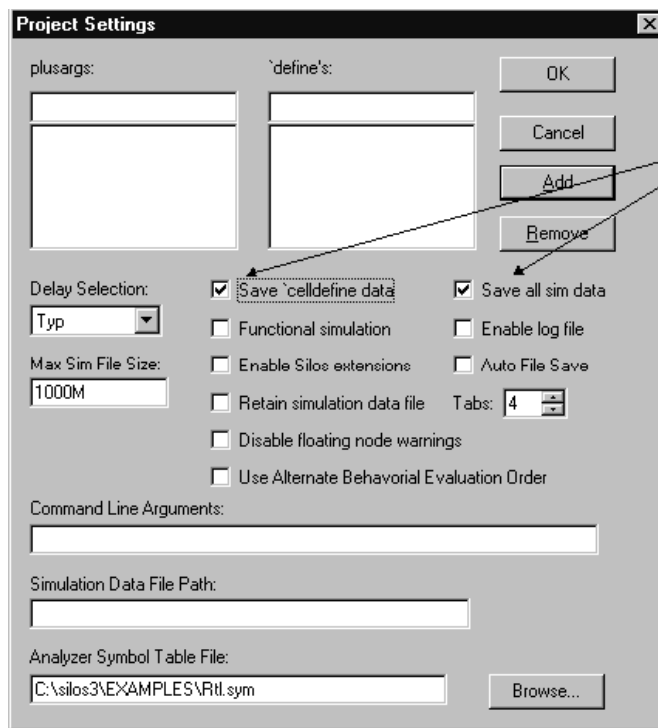

Ensure these items are checked if you see “No Saved Data” in Data Analyzer.

If the Data Analyzer reports “No Saved Data” for a waveform, check the following:

- The “Save `celldefine data” option in the Project Settings screen may need to be enabled (**Project/Project Settings**). This will save the local variables for modules in library cells

- that are bounded by ``celldefine` and ``endcelldefine`.
- The “Save all sim data” option in the Project Settings screen may need to be enabled (**Project/Project Settings**). This will save the simulation history for every variable.
- The “Save simulation data for this entry” in the Module Properties screen may need to be enabled (**Explorer window/Tree/Properties**). See Keeping Module Instance Simulation Variable Values for a simpler method of saving instances in the hierarchy.

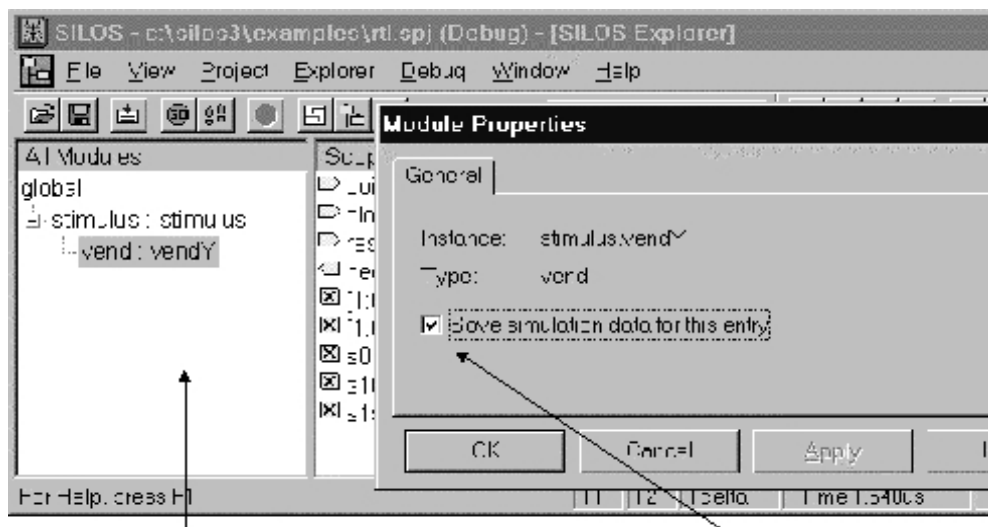

Click with right mouse button on the left side of the Explorer window to open pop-up menu.

Save simulation entry should be checked to save the simulation history

B.3.11 Help Menu

B.3.11.1 Help/Contents

Opens the contents listing for the SILOS III User's Manual on-line help file.

B.3.11.2 Help/Using Help

Opens a Microsoft help file for an explanation of how to effectively use the Index and on-line Help.

B.3.11.3 Help/SILOS III User's Manual

Provides the complete SILOS III User's Manual.

B.3.11.4 Help/Verilog LRM

Provides the complete OVI Verilog Language Reference Manual version 1.0.

B.3.11.5 Help/SDF Manual

Provides the complete OVI Standard Delay Format (SDF) Manual version 2.0.

B.3.11.6 Help/About SSE

Opens the About SILOS Simulation Environment screen. This screen contains the SILOS III version number, copyright notice, and the total memory allocated in RAM memory for SILOS III. The memory usage for SILOS III is constant for logic simulation. If you select the **Load/Reload Input Files** button on the Main toolbar, SILOS III will simulate to time=0. You can then use the About SILOS Simulation Environment screen to determine the RAM memory usage for your design during logic simulation.

B.3.12 Pop-up Menus

SILOS III has pop-up menus for the Watch window, Explorer window, Data Analyzer window, Output window, and the source windows,. The pop-up menus for the Output window and the source windows allow you to Cut, Copy, and Paste.

The pop-up menus for windows are:

- The right-hand side of the Explorer window has a pop-up menu for the **Add Signals to Analyzer** and **Name Filter** commands. To invoke this pop-up menu, use the right mouse

button to click on any part of the right-hand side (the side with the signal names) of the Explorer window. The pop-up menu will remain open while the left mouse button is used to select a menu item.

- The left-hand side of the Explorer window has a pop-up menu for the **Copy Scope, Go To Module Source, Go To Scope, and Properties** command. To invoke this pop-up menu, use the right mouse button to click on any part of the left-hand side (the side with the hierarchical tree) of the Explorer window. The pop-up menu will remain open while the left mouse button is used to select a menu item.
- The Watch window has a pop-up menu for the **Add Signal/Expression, Set Value, Free Forced Wire, and Clear All** commands. To invoke this pop-up menu use the right mouse button to click on any part of the Watch window. The pop-up menu will remain open while the left mouse button is used to select a menu item.
- The Data Analyzer has a pop-up menu for the **Goto Timepoint, Pan to T1, Pan to T2, Pan to Last View, Timescale, Snap to Edges, Add Bookmark and Delete Bookmark** commands. To invoke this pop-up menu use the right mouse button to click on any part of the time point display area (the gray area just above the Waveform Display window). The pop-up menu will remain open while the mouse is used to select a menu item.
- The Data Analyzer has a pop-up menu for the **Trace Signal Inputs, Display Iteration Data, New Group, Delete Group, Insert Group, Show Groups, Set Radix, Add “One” Bit, Add “Zero” Bit, Reverse Bit Order, Add Signal, Add Blank Line, and Clear Signal List** commands. To invoke this pop-up menu, use the right mouse button to click on any part of the **Signal** list box.

B.3.12.1 Explorer Window

B.3.12.1.1 Add Signals to Analyzer

Useful for adding signals to the Data Analyzer when it is difficult to drag and drop the signals due the screen size.

To use this command, right-click on any part of the right hand side of the Explorer window to open the pop-up menu.

B.3.12.1.2 Name Filter

The name filtering in the Explorer window uses regular expressions. Explanations for regular expressions can be found in many programming books. A short description of regular expressions is provided in this help file.

A regular expression is a notation for specifying and matching strings. Regular expressions have two basic kinds of characters:

- **Special characters:** These are characters that have special meaning for matching strings. The special characters for regular expressions are:

`\ ^ $. [] * + ?`

where:

- `\` This escapes or quotes other characters, such as `\$` matches the “\$”. A useful quoted string is `\\` which means “or”. Another useful quoted string is `\(` and `\)` which allow the parenthesis to be used to group regular expressions. For example, `ac*` means the character “a” and zero or more characters of “c”. However, `\(ac\)*` means zero or more occurrences of the character string “ac”.
- `^` This matches the preceding character at the beginning of a string. When `^` is the first character in a character class it means the compliment of the character class.
- `$` This matches the preceding character at the end of a string.
- `.` This matches any single character.
- `[]` Characters enclosed in brackets are a character class.
- `*` This matches zero or more occurrences of the character that precedes the `*`.
- `+` This matches one or more occurrences of the character that precedes the `+`.
- `?` This matches zero or one occurrence of the character that precedes the `?`.

- **Ordinary characters:** These are all the other available characters. These characters match themselves, such as “a” would match the letter “a”.

The character class `[]` has special rules. Inside a character class, all characters have their literal meaning, except for the quoting character `\`, `^` at the beginning, and `-` between two characters. Each of the characters in a character class are treated as an “or” search. For example, `[ab]` will find any single character name “a” or “b”. The character class `[a-z]` will match any single character lower case name. The character class `[^a-zA-Z]` will match any single character name that is not an alpha.

Some examples of using regular expressions are listed below:

- `a` matches only the name lowercase “a”
- `a.*` matches any name that begins with “a”.
- `.*a` matches any name that ends with “a” and the name “a”.
- `.*a.*` matches any name that has an “a” anywhere in the name.
- `[abc]` matches only the names “a” or “b” or “c”.

| | |
|---------------|---------------------------------------------------------------------------------------------------------------------------------------------------------------|
| [a-z] | matches any name that is a single lower case character, such as "b". |
| [a-z]* | matches any name that is only lower case characters, for example "data". |
| [a-zA-Z]* | matches any name that is upper and/or lower case characters, for example "data", "DATA" and "Data". |
| [a-zA-Z0-9]* | matches any name that has upper and/or lower case characters and/or digits, for example "data", "DATA", "Data", "123", "data1". |
| [a-zA-Z0-9_]* | matches any name that has upper and/or lower case characters, and/or digits, and/or "_", for example "data", "DATA", "Data", "123", "data1", and "DATA_bus1". |

Some programming books (such as AWK and Perl) show regular expressions enclosed with slashes `/ /`. The SILOS III style of searching for regular expressions is a character search and forward slashes have no special meaning. For example, using the regular expression `/a/` to try to find any name that contains an "a" will find only the name `/a/`.

Regular expressions are not like the Unix style wildcards (where `?` matches any single character, `*` matches any pattern, and `[list]` matches any character in list including ranges). For example, using the regular expression `*a*` to find any name that contains an "a" will not find any names.

If you want use regular expressions to find every name that has an "a", you can enter:

```
. *a . *
```

For the above expression, `" . *a . *"` means search for zero or more occurrences (the first `"*"`) of any character (the first `" . "`), followed by a single character `"a"`, followed by zero or more occurrences (the second `"*"`) of any character (the second `" . "`). So, with the search `" . *a . *"` you could find names such as `"a"`, `"data"`, `"read"`, etc.

B.3.12.1.3 Copy Scope

Located in the pop-up menu in the left hand "Tree" side of the Explorer window. When you select a hierarchical instance in the Explorer window, the **Copy Scope** command (or simultaneously holding down the CTRL and C keys) will copy the hierarchical instance name to the Windows Clipboard. This enables you paste the hierarchical name (simultaneously holding down the CTRL and C keys).

To use this command, right-click on any part of the left hand side of the Explorer window to open the pop-up menu.

B.3.12.1.4 Go to Module Source

Located in the pop-up menu in the left hand "Tree" side of the Explorer window. When you select a hierarchical instance in the Explorer window, the **Go to Module Source** command

opens a source window that displays the source code for the hierarchical instance. This enables you to quickly find the source code for any instance in your design.

To use this command, right-click on any part of the left hand side of the Explorer window to open the pop-up menu.

B.3.12.1.5 Go to Scope Menu Selection

Located in the pop-up menu in the left hand “Tree” side of the Explorer window. This feature enables you to quickly find an instance in the Explorer window. The **Go to Scope** command opens the Enter Scope screen, where you specify the scope for the instance that you want to find. Then click **Ok** and the Explorer window will highlight the instance you selected.

To invoke this menu selection, right-click on any part of the left hand side of the Explorer window to open the pop-up menu.

B.3.12.1.6 Properties

Located in the pop-up menu in the left hand “Tree” side of the Explorer window. The **Properties** command opens the Module Properties screen. The Module Properties screen enables you to specify which module instances you want to save the simulation data for during simulation. See Keeping Module Instance Simulation Variable Values for a simpler method of saving instances in the hierarchy.

If the “Save simulation data for this entry” is selected, then SILOS III saves the simulation data for the following items during simulation:

- All local variables for the module instance;
- All port variables for the module instance (even if the ports connect to module instances that are not saved below it in the hierarchy);
- Any instance below it in the hierarchy of the design, unless the instance below it is specifically not saved.

If the “Save simulation data for this entry” is not selected, then SILOS III does not save the simulation data for following items during simulation:

- All local variables for the module instance not selected;
- The simulation data for any instance below it in the hierarchy of the design.

Before the “Save simulation data for this entry” specifications can take effect, the Project must be reloaded by using **Project/Open** or by selecting a project name from the Most Recently Used list of projects at the bottom of the **Project** menu.

To invoke this command, right-click on any part of the left hand side of the Explorer window to open the pop-up menu.

B.3.12.2 Watch Window

B.3.12.2.1 Add Signal/Expression

Opens the Specify Signal/Expression screen. To use this command, right-click on any part of the Watch window to open the pop-up menu.

The Specify Signal/Expression screen contains an edit box “**Scope**” to specify the scope for the signal. The Specify Signal/Expression screen also contains an edit box “**Signal/Expression**” to enter a signal or an expression. Any valid Verilog HDL expression can be entered. If the expression or scope is not valid then the expression will list an “Error”.

The **OK** button closes the screen and displays the specified expression in the Watch window. The **Cancel** button closes the screen and does not display the expression.

B.3.12.2.2 Set Value For Watch Window

Can be used to force or set a vector in the Watch window. To use this command, right-click on any part of the Watch window to open the pop-up menu.

B.3.12.2.3 Free Forced Wire For Watch Window

Frees a wire that has been forced in the Watch window. To use this command, right-click on any part of the Watch window to open the pop-up menu.

B.3.12.2.4 Clear All For Watch Window

Clears all of the expressions from the Watch window. To use this command, right-click on any part of the Watch window to open the pop-up menu.

B.3.12.3 Data Analyzer Pop-up Menus

B.3.12.3.1 Data Analyzer Timeline Area

Goto Timepoint

Opens the Goto Timepoint screen for specifying the time point for the left axis or the center of the Waveform Display window. The Goto Timepoint screen enables you to precisely position the Waveform Display window for debugging and printing. The time value for the **Time Point** box can be specified in any standard time unit, such as “ns” for nano seconds, “ps” for pico seconds, etc., i.e.: 12000.3ns

To use this command, right-click on any part of the timeline display area (the gray area just above the Waveform Display window).

Pan to T1, Pan to T2, and Pan to Last View

Analyzer/Timepoint/Pan to T1 and **Pan to T2** will center the Waveform Display window around the T1 or T2 timing marker. **Pan to Last View** will return the Waveform Display window to the preceding view. These commands are useful during debugging for jumping between views of the simulation results.

To invoke the pop-up menu, right-click on any part of the timeline display area (the gray area just above the Waveform Display window).

Timescale

Opens the Time Scale screen for setting the number of time units per division of display. Setting the timescale is useful for debugging the design.

The current time scale, T1 time value, T2 time value, and delta time value can be displayed by holding the mouse cursor over the timeline for a few seconds. To modify the time scale, open the Time Scale screen and enter a value in the **Time/Div** box. You can use any standard time unit, such as “ns” for nano seconds, “ps” for pico seconds, etc. i.e.: 12000 . 3ns

The **OK** button closes the screen and causes the Data Analyzer to use the selected time scale. The **Cancel** button closes the screen and does not affect the Data Analyzer.

To invoke the pop-up menu, right-click on any part of the time point display area (the gray area just above the Waveform Display window).

Snap to Edges

When setting the T1 and T2 timing markers for the Data Analyzer, they will snap to the nearest edge if **Analyzer/Timepoint/Snap to Edges** is active.

When setting a timing marker, you can hold down the SHIFT key to temporarily toggle the **Snap to Edges** selection to its opposite effect. Such as, if **Snap to Edges** is not selected, you can have the timing marker snap to the nearest edge when you set it by holding down the SHIFT key as you click using the left or right mouse button with the mouse indicator (arrow) in the Waveform Display window.

To invoke the pop-up menu, right-click on any part of the time point display area (the gray area just above the Waveform Display window).

Add Bookmark

Enables you to place a virtual marker for the time and the timescale resolution of the center of the Waveform Display window. When debugging your design, the bookmarkers you set enable you to jump back and forth between waveform views with the same or different timescale.

After opening the Add Bookmark screen you will see the default bookmarks, i.e. “Bookmark1”, “Bookmark2”, etc. You can specify any string of characters for the bookmark name and then click-on OK to set the bookmark. The bookmarks you have set are listed at the bottom of the pop-up menu. To go to a bookmarker select it with the left mouse button.

To invoke the pop-up menu, right-click on any part of the time point display area (the gray area just above the Waveform Display window).

Delete Bookmark

Enables you to delete a bookmarker.

After opening the Delete Bookmark screen you will see the bookmarkers, i.e. “Bookmark1”, “Bookmark2”, listed in the **Bookmarks** list box. You can delete a bookmark by selecting it with the mouse and clicking **Delete**. Click **OK** to close the screen.

To invoke the pop-up menu, right-click on any part of the time point display area (the gray area just above the Waveform Display window).

B.3.12.3.2 Data Analyzer Signal List Box

Trace Signal Inputs Menu Selection

Opens a Trace Signal Inputs window. The Trace Signal Inputs window allows you to interactively trace an incorrect value at a net to its cause by displaying the waveforms of all the devices that are driving the net.

To invoke the pop-up menu, right-click on any part of the Name list box.

When you wish to trace a net, highlight a signal name in the **Name** list box of the Data Analyzer. With the mouse cursor still in the **Name** list box, right-click to open the pop-up menu. Next, choose **Trace Signal Inputs** from the pop-up menu. A Trace Signal Inputs window will then be opened and it will display the signals that are driving the net you selected.

To continue the fan-in tracing, double-click on any input and the waveform for that node will be displayed along with the waveforms for the devices driving it. To “undo” your signal tracing, double-click on the node name that is being traced.

When the waveforms for the Trace Signal Inputs window are displayed, the name of the node being traced is listed first in the **Name** box. Blank lines delineate each device listed in the **Name** box. The format for each device is similar to the format for a module instance when passing ports by name in Verilog HDL. For example, the name:

```
not top.bit4.dff2.n6 (
    .out (top.bit4.dff2.\q_<specify> )
    .in  (top.bit4.dff2.\qbar_<specify> ))
```

The device is a **"not"** gate and the instance name is **"top.bit4.dff2.n6"**. The output port name **".out"** has the instance name **"top.bit4.dff2.\q_<specify>"**. The input port name **".in"** has the instance name **"top.bit4.dff2.\q_<specify>"**.

You can continue to double-click on device inputs and trace your way back through the topology. To **"undo"** your signal tracing, double-click on the signal name that was traced. If you see **"No Saved Data"** instead of a waveform, this may mean that the signal is inside of a ``celldefine` boundary. To save data within ``celldefine` boundaries, see the **"Save `celldefine data"** option in Project/Project Settings.

Display Iteration Data

Useful for finding order of evaluation problems and race conditions.

To invoke the pop-up menu, right-click on any part of the **Name** list box.

When the **Display Iteration Data** command is chosen, it opens an Iteration Data window that displays all of the iterations at a single timepoint for each signal in the **Name** list box. The timepoint to display the iterations is specified by the T1 timing marker.

To display a text report for iterations at a timepoint, see Reports/Iteration.

Groups of Signals

Using groups provides a convenient method for organizing your signals in the Data Analyzer window. Not only does this help organize the display of your signals, it also prevents you from losing your list of signals if the default group gets inadvertently changed or lost. Display groups are also useful for assisting engineers who are unfamiliar with the design, and for record keeping if the design is reused.

The pop-up menu for the **Name** list box provides the following selections for groups:

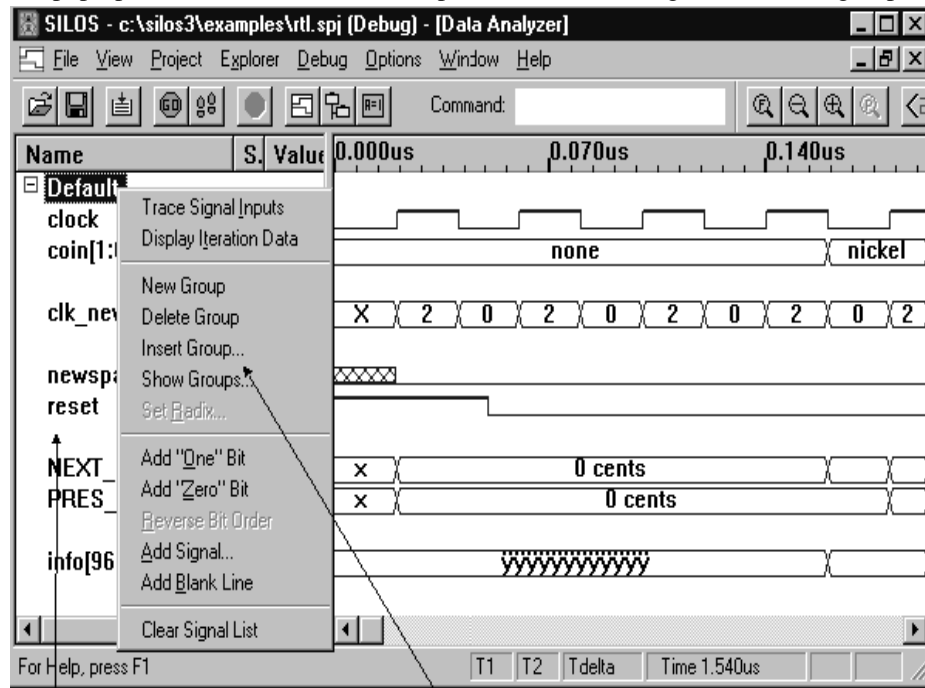

Signal list box

Selections for groups

- **New Group:** This selection can be used to add a new group to the **Name** list box.
- **Delete Group:** This selection can be used to delete a group.
- **Insert Group:** This selection opens the Add Group screen. This screen will insert a group within a group. The inserted group is displayed as a bus, which can be expanded and hidden by double-clicking on it.
- **Show Groups:** This selection opens the Select Signal Groups screen. This screen can be used to select which groups are displayed in the Data Analyzer.

To invoke the pop-up menu, right-click on any part of the **Name** list box. The pop-up menu will remain open while the mouse is used to select the group menu item of interest.

When the Data Analyzer window is opened, the “Default” group is displayed. To save any signals that are added to the Default group, click on the minus sign “-” just to the left of the Default group in the **Name** list box. SILOS III will ask you if you want to save the changes to the Default group.

Set Radix

Located in the pop-up menu for the **Name** list box. Setting the radix for a vector can assist with debugging the design. The radix can be set to binary, octal or hexadecimal to conveniently display the vector. Symbolic names can be used to represent the values for a state machine. ASCII vectors can be displayed to create a timeline of events for the Data Analyzer display.

To invoke the pop-up menu, right-click on any part of the **Name** list box.

- To set the radix for a vector:
 1. Right-click on the vector to open the pop-up menu.
 2. Choose **Set Radix** from the pop-up menu.
 3. The Set Radix screen will then be opened and you can select the Radix.
 4. If you select the “Symbol Table” radix, then select the correct symbol table in the **Symbol Table** box.
 5. To close the screen and set the vector to the selected radix, click **OK**. Clicking **Cancel** closes the screen and does not affect the vector's radix.

“Bit” Commands

The pop-up menu for the **Name** list box for the Data Analyzer has the following commands:

- Add “One” Bit: Adds a single bit signal at a high level just ahead of the selected signal name.
- Add “Zero” Bit: Adds a single bit signal at a low level just ahead of the selected signal name.
- Reverse Bit Order: Reverses the signal order for the highlighted signals in the Name list box. This is useful for reversing the bit order for a group.

To invoke the pop-up menu, right-click on any part of the **Name** list box.

Add Signal

Opens the Specify Signal/Expression screen.

Adding a signal can be very useful for performing conditional searches. The added waveform can be any expression whether the expression exists in your HDL source code or not. For a conditional search, you can then use the scan to change feature and the States List Box to review the signal values for the conditional search.

The Add Signal feature can also be useful for adding expressions that exist in your source code, such as for an “if” test, and then viewing then the expression is true (high).

The Specify Signal/Expression screen contains an edit box “Scope” to specify the scope for the signal. The Specify Signal/Expression screen also contains a **Signal or (Expression)** edit box to enter a signal or an expression. Any valid Verilog HDL expression can be entered,

however, the expression must be enclosed by parentheses. You can copy and paste an expression that is in your source code window by highlighting the expression and using the CTRL C keys to copy and the CTRL V keys to paste the expression into the Signal or (Expression) list box. If the expression or scope is not valid then the waveform will be blank.

The **OK** button closes the screen and displays the specified expression in the Data Analyzer. The **Cancel** button closes the screen and does not display the expression.

Add Blank Line

Inserts a blank line in the Data Analyzer just above the signal name that is highlighted.

Clear Signal List

Deletes all of the signal names in the **Name** list box.

Reload Groups

Causes the Data Analyzer to clear the list box and reload the group information from the project file. This is useful when a user written program is used to modify the groups while the SSE is running.

B.3.12.4 Source Window Pop-up Menus

B.3.12.4.1 Undo

Undoes your last editing or formatting action, including cut and paste actions. If an action cannot be undone, **Undo** appears dimmed on the pop-up menu.

To invoke the pop-up menu, right-click on any part of the source window.

B.3.12.4.2 Cut

Deletes text from a document and places it onto the Clipboard, replacing the previous Clipboard contents.

To invoke the pop-up menu, right-click on any part of the source window.

B.3.12.4.3 Copy

Copies text from a document onto the Clipboard, leaving the original intact and replacing the previous Clipboard contents.

To invoke the pop-up menu, right-click on any part of the source window.

B.3.12.4.4 Paste

Pastes a copy of the Clipboard contents at the insertion point, or replaces selected text in a document.

To invoke the pop-up menu, right-click on any part of the source window.

B.3.12.4.5 Add/Remove Breakpoint

Places or removes a simulation breakpoint at the location of the cursor in the source window.

To invoke the pop-up menu, right-click on any part of the source window.

B.3.12.4.6 Data Tips

Toggles the Data Tips capability “on” or “off”. The Data Tips capability displays the value, scope, radix, and simulation time point for a variable or expression in the source window. Any variable or expression in a source window can be viewed by opening the source window and holding the mouse cursor over a variable or by highlighting an expression and holding the mouse cursor over the expression. This feature enables you to trace the cause of problems directly in a Verilog HDL source code window.

To invoke the pop-up menu, right-click on any part of the source window.

B.3.12.4.7 Data Tip Radix

Sets the radix for the Data Tips capability. The allowed radices are binary, octal, hexadecimal, decimal and string.

The Data Tips capability displays the value, scope, radix, and simulation time point for a variable or expression in the source window. Any variable or expression in a source window can be viewed by opening the source window and holding the mouse cursor over a variable or by highlighting an expression and holding the mouse cursor over the expression. This feature enables you to trace the cause of problems directly in a Verilog HDL source code window.

To invoke the pop-up menu, right-click on any part of the source window.

Appendix C

Sources Components

| | | |
|------|------------------------------------------------|-----|
| C.1 | Ground | C-1 |
| | C.1.1 About Grounding. | C-1 |
| | C.1.2 The Ground Component. | C-1 |
| C.2 | Digital Ground | C-2 |
| C.3 | DC Voltage Source (Battery). | C-2 |
| | C.3.1 Battery Background Information | C-2 |
| | C.3.2 Battery Component. | C-3 |
| C.4 | VCC Voltage Source. | C-3 |
| C.5 | DC Current Source | C-3 |
| C.6 | AC Voltage Source | C-3 |
| C.7 | AC Current Source | C-4 |
| C.8 | Clock Source. | C-4 |
| C.9 | Amplitude Modulation (AM) Source | C-4 |
| | C.9.1 Characteristic Equation. | C-4 |
| C.10 | FM Source. | C-5 |
| | C.10.1FM Voltage Source. | C-5 |
| | C.10.2Characteristic Equation | C-5 |
| | C.10.3FM Current Source. | C-6 |
| | C.10.4Characteristic Equation | C-6 |
| C.11 | FSK Source | C-6 |
| C.12 | Voltage-Controlled Voltage Source. | C-7 |
| C.13 | Current-Controlled Voltage Source. | C-7 |
| C.14 | Voltage-Controlled Current Source. | C-8 |
| C.15 | Current-Controlled Current Source. | C-8 |
| C.16 | Voltage-Controlled Sine Wave | C-8 |
| | C.16.1The Component | C-8 |

| | |
|----------------------------------------------------------|------|
| C.16.2Example | C-9 |
| C.17 Voltage-Controlled Square Wave | C-10 |
| C.17.1The Component. | C-11 |
| C.17.2Example | C-11 |
| C.18 Voltage-Controlled Triangle Wave | C-12 |
| C.18.1The Component. | C-13 |
| C.18.2Example | C-13 |
| C.19 Voltage-Controlled Piecewise Linear Source. | C-14 |
| C.20 Piecewise Linear Source | C-15 |
| C.20.1The Component. | C-15 |
| C.20.1.1Example | C-16 |
| C.20.1.2Input Text File Specification. | C-16 |
| C.20.1.3Special Considerations | C-17 |
| C.20.2Piecewise Linear Voltage Source | C-18 |
| C.20.3Piecewise Linear Current Source | C-18 |
| C.21 Pulse Source | C-18 |
| C.21.1Pulse Voltage Source | C-19 |
| C.21.2Pulse Current Source | C-20 |
| C.22 Polynomial Source | C-20 |
| C.22.1 Output Voltage Characteristic Equation | C-20 |
| C.23 Exponential Source | C-21 |
| C.23.1Exponential Voltage Source | C-22 |
| C.23.2Exponential Current Source | C-22 |
| C.24 Nonlinear Dependent Source. | C-22 |
| C.25 Controlled One-Shot | C-23 |

Appendix C Sources Components

C.1 Ground



C.1.1 About Grounding

A voltage measurement is always referenced to some point, since a voltage is actually a ‘potential difference’ between two points in a circuit.

The concept of ‘ground’ is a way of defining a point common to all voltages. It represents 0 volts. All voltage levels around the circuit are positive or negative when compared to ground. In power systems, the planet Earth itself is used for this reference point (most home power circuits are ultimately ‘grounded’ to the Earth’s surface for lightning protection). This is how the expression ‘earthing’ or ‘grounding’ a circuit originated.

Most modern power supplies have ‘floating’ positive and negative outputs, and either output point can be defined as ground. These types of supplies can be used as positive (with respect to ground) or negative power supplies. In floating power supply circuits, the positive output is often used as the voltage reference for all parts of the circuit.

Note Multisim supports a multipoint grounding system. Each ground connected is made directly to the ground plane.

C.1.2 The Ground Component

This component has 0 voltage and so provides a clear reference point for calculating electrical values. You can use as many ground components as you want. All terminals connected to ground components represent a common point and are treated as joined together.

Not all circuits require grounding for simulation; however, any circuit that uses an opamp, transformer, controlled source or oscilloscope must be grounded. Also, any circuit which contains both analog and digital components should be grounded. If a circuit is ungrounded or improperly grounded (even if it does not need grounding in reality), it may not be simulated. If it is simulated, it may produce inconsistent results. The linear transformer must be grounded on both sides.

C.2 Digital Ground

⚡ The digital ground is used to connect ground to the digital components which do not have an explicit ground pin. The digital ground must be placed on the schematic but should not be connected to any component.

C.3 DC Voltage Source (Battery)



C.3.1 Battery Background Information

A battery may be a single electrochemical cell or a number of electrochemical cells wired in series. It is used to provide a direct source of voltage and/or current.

A single cell has a voltage of approximately 1.5 volts, depending on its construction. It consists of a container of acid in which an electrode is placed. Chemical action causes electrons to flow between the electrode and the container, and this creates a potential difference between the electrode and the material of the container.

Batteries can be rechargeable and can be built to deliver extremely high currents for long periods. The automobile ignition battery is an application of a battery as a “current source”; the voltage may vary considerably under use, with no visible battery deterioration.

Batteries may be used as voltage references, their voltage remaining stable and predictable to many figures of accuracy for many years. The standard cell is such an application. A standard cell is a voltage source, and it is important that current is not drawn from the standard cell.

C.3.2 Battery Component

This source can be adjusted from μV to kV , but the value must be greater than zero.

Tip The battery in Multisim has no resistance. If you want to use a battery in parallel with another battery or a switch, insert a 1-mW resistor in series with it.

Battery tolerance is, by default, set to the global tolerance (defined in the Analysis/Monte Carlo dialog box). To set the tolerance explicitly, de-select “Use global tolerance” and enter a value in the “voltage tolerance” field.

C.4 VCC Voltage Source

 The VCC Voltage Source is used to connect power to the digital components which do not have an explicit power pin. The VCC Voltage Source must be placed on the schematic and can be used as a DC voltage source. The value of VCC can be set by using the Digital Power dialog box, which appears when you right-click on the VCC symbol. Multiple VCC symbols may be placed on a schematic but there is only one VCC net in the schematic. Only one value of VCC voltage is possible in the design with both positive and negative values being supported.

C.5 DC Current Source



The current generated by this source can be adjusted from μA to kA .

DC current source tolerance is, by default, set to the global tolerance (defined in the Analysis/Monte Carlo dialog box). To set the tolerance explicitly, de-select “Use global tolerance” and enter a value in the “current tolerance” field.

C.6 AC Voltage Source

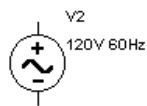

The root-mean-square (RMS) voltage of this source can be adjusted from μV to kV . You can also control its frequency and phase angle.

$$V_{RMS} = \frac{V_{peak}}{\sqrt{2}}$$

AC voltage source tolerance is, by default, set to the global tolerance (defined in the Monte Carlo Analysis screen). To set the tolerance explicitly, de-select “Use global tolerance” and enter a value in the “voltage tolerance” field.

C.7 AC Current Source

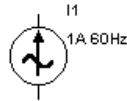

The RMS current of this source can be adjusted from μA to kA . You can also control its frequency and phase angle.

$$I_{RMS} = \frac{I_{peak}}{\sqrt{2}}$$

AC current source tolerance is, by default, set to the global tolerance (defined in the Analysis/Monte Carlo dialog box). To set the tolerance explicitly, de-select “Use global tolerance” and enter a value in the “current tolerance” field.

C.8 Clock Source

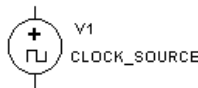

This component is a square wave generator. You can adjust its voltage amplitude, duty cycle and frequency.

C.9 Amplitude Modulation (AM) Source

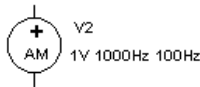

The AM source (single-frequency amplitude modulation source) generates an amplitude-modulated wave. It can be used to build and analyze communications circuits.

C.9.1 Characteristic Equation

The behavior of the AM source is described by:

$$V_{OUT} = v_c * \sin(2 * \pi * f_c * TIME) * (1 + m * \sin(2 * \pi * f_m * TIME))$$

where

- vc = carrier amplitude, in volts
- fc = carrier frequency, in hertz
- m = modulation index
- fm = modulation frequency, in hertz

C.10 FM Source

The FM source (single-frequency frequency modulation source) generates a frequency-modulated wave. It can be used to build and analyze communications circuits. The signal output can be either a current source or a voltage source.

C.10.1 FM Voltage Source

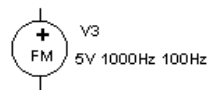

This is an FM source of which the output is measured in voltage.

C.10.2 Characteristic Equation

The behavior of the FM voltage source is described by:

$$V_{OUT} = va * \sin(2 * \pi * fc * TIME + m * \sin(2 * \pi * fm * TIME))$$

where

- va = peak amplitude, in volts
- fc = carrier frequency, in Hz
- m = modulation index
- fm = modulation frequency, in Hz

C.10.3 FM Current Source

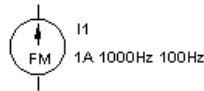

This component is the same as the the FM voltage source, except that the output is measured in current.

C.10.4 Characteristic Equation

The behavior of the FM current source is described by the same equation as in C.10.2, with V_{out} replaced by I_{out} .

C.11 FSK Source

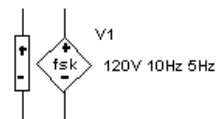

This source is used for keying a transmitter for telegraph or teletype communications by shifting the carrier frequency over a range of a few hundred hertz. The frequency shift key (FSK) modulated source generates the mark transmission frequency, f_1 , when a binary 1 is sensed at the input, and the space transmission frequency, f_2 , when a

0 is sensed.

FSK is used in digital communications systems such as in low speed modems (for example, a Bell 202 type modem - 1200 baud or less).

In this system, a digital high level is referred to as a MARK and is reproduced as a frequency of 1200 Hz. A digital low level is referred to as a SPACE and is represented by a frequency of 2200 Hz.

In the example shown below, the frequency shift keying signal is a 5v (TTL) square wave.

When the keying input is 5V, a MARK frequency of 1200 Hz is output. When keying voltage is 0V, a SPACE frequency of 2200 Hz is output.

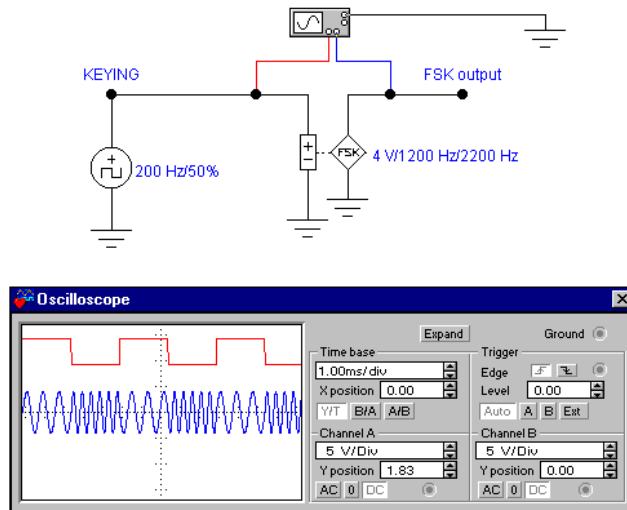

This component is a square wave generator. You can adjust its voltage amplitude, duty cycle and frequency.

C.12 Voltage-Controlled Voltage Source

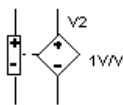

The output voltage of this source depends on the voltage applied to its input terminal. The ratio of the output voltage to the input voltage determines its voltage gain (E). Voltage gain can have any value from mV/V to kV/V.

$$E = \frac{V_{OUT}}{V_{IN}}$$

C.13 Current-Controlled Voltage Source

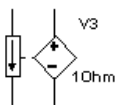

The output voltage of this source depends on the current through the input terminals. The two are related by a parameter called transresistance (H), which is the ratio of the output voltage to the input current. It can have any value from mW to kW.

$$H = \frac{V_{OUT}}{I_{IN}}$$

C.14 Voltage-Controlled Current Source

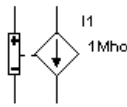

The output current of this source depends on the voltage applied at the input terminals. The two are related by a parameter called transconductance (G), which is the ratio of the output current to the input voltage. It is measured in mhos (also known as seimens) and can have any value from mmhos to kmhos.

$$G = \frac{I_{OUT}}{V_{IN}}$$

C.15 Current-Controlled Current Source

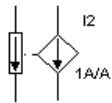

The magnitude of the current output of a current-controlled current source depends on the current through the input terminals. The two are related by a parameter called current gain (F), which is the ratio of the output current to the input current. The current gain can have any value from mA/A to kA/A.

$$F = \frac{I_{OUT}}{I_{IN}}$$

C.16 Voltage-Controlled Sine Wave

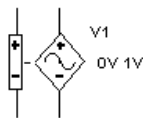

C.16.1 The Component

This oscillator takes an input AC or DC voltage, which it uses as the independent variable in the piecewise linear curve described by the (control, frequency) pairs. From the curve, a frequency value is determined, and the oscillator outputs a sine wave at that frequency. When

only two co-ordinate pairs are used, the oscillator outputs a linear variation of the frequency with respect to the control input. When the number of co-ordinate pairs is greater than two, the output is piecewise linear. You can change the peak and valley values of the output sine wave by resetting the Output peak high value and Output peak low value on the model parameter dialog box.

C.16.2 Example

The example shows a sine wave generator with output frequency determined by a control voltage.

Control voltage may be DC, controlled by a potentiometer, as is the case for many signal generators and function generators, or may be the output from a PLL that determines a precise frequency.

Control voltage may be a continuous variable of any desired shape as required in sweep generators and spectrum analysers.

In the example shown below, the VCO parameters are set so that control voltage of 0V produces an output frequency of 100Hz and a control voltage of 12V produces an output frequency of 20KHz.

A square wave control voltage produces a form of FSK (frequency shift keying), a sine wave control voltage produces a form of FM (frequency modulation).

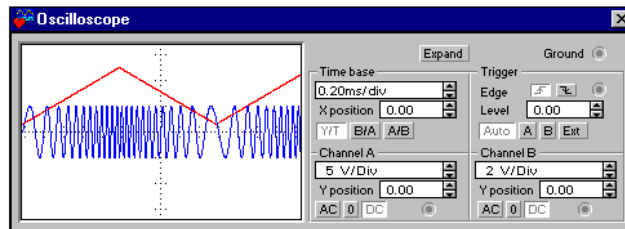
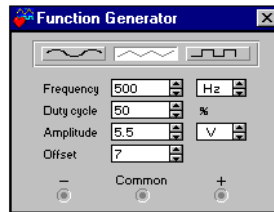
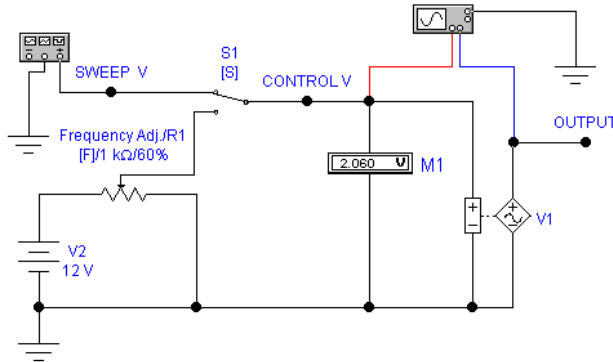

C.17 Voltage-Controlled Square Wave

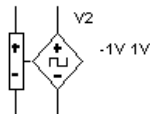

C.17.1 The Component

This oscillator is identical to the voltage-controlled sine wave oscillator except that it outputs a square wave. This oscillator takes an input AC or DC voltage, which it uses as the independent variable in the piecewise linear curve described by the (control, frequency) pairs. From the curve, a frequency value is determined, and the oscillator outputs a square wave at that frequency. When two co-ordinate pairs are used, the oscillator outputs a linear variation of the frequency with respect to the control input. When the number of co-ordinate pairs is greater than two, the output is piecewise linear. You can change duty cycle, rise and fall times, and the peak and valley values of the output square wave by resetting the Output peak high value and Output peak low value on the model parameter dialog box.

C.17.2 Example

The example shows a square wave generator with output frequency determined by a control voltage.

Control voltage may be DC, controlled by a potentiometer, as is the case for many signal generators and function generators.

Control voltage may be a continuous variable of any desired shape as required in sweep generators and spectrum analysers.

In the example shown below, the VCO parameters are set so that control voltage of 0V produces an output frequency of 100Hz and control voltage of 12V produces an output frequency of 20KHz.

A square wave control voltage produces a form of FSK (frequency shift keying), a sine wave control voltage produces a form of FM (frequency modulation).

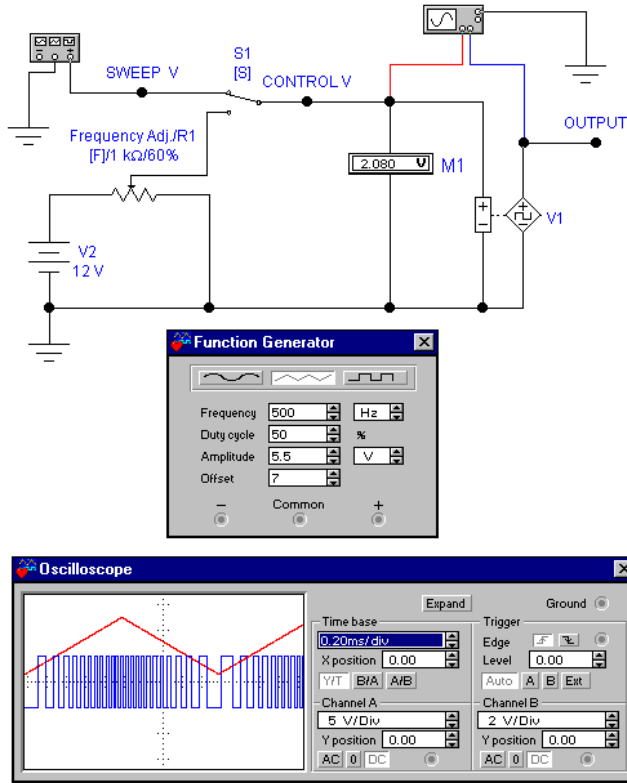

C.18 Voltage-Controlled Triangle Wave

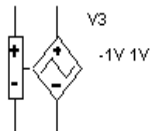

C.18.1 The Component

This oscillator is identical to the voltage-controlled sine wave oscillator except that it outputs a triangle wave. This oscillator takes an input AC or DC voltage, which it uses as the independent variable in the piecewise linear curve described by the (control, frequency) pairs. From the curve, a frequency value is determined, and the oscillator outputs a triangle wave at that frequency. When two co-ordinate pairs are used, the oscillator outputs a linear variation of the frequency with respect to the control input. When the number of co-ordinate pairs is greater than two, the output is piecewise linear. You can change the rise time duty cycle and the peak and valley values of the output triangle wave by resetting the Output peak high value and Output peak low value on the model parameter dialog box.

C.18.2 Example

The example shows a triangle wave generator with output frequency determined by a control voltage.

Control voltage may be DC, controlled by a potentiometer, as is the case for many signal generators and function generators.

Control voltage may be a continuous variable of any desired shape as required in sweep generators and spectrum analysers.

In the example shown below, the VCO parameters are set so that control voltage of 0V produces an output frequency of 100Hz and control voltage of 12V produces an output frequency of 20KHz.

A square wave control voltage produces a form of FSK (frequency shift keying), a sine wave control voltage produces a form of FM (frequency modulation).

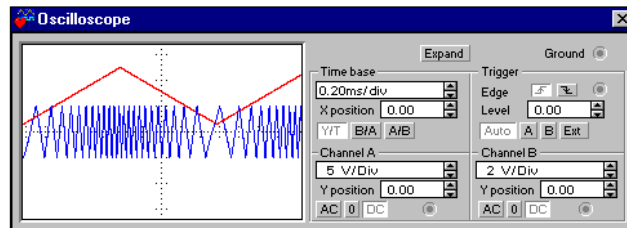
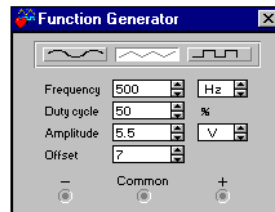
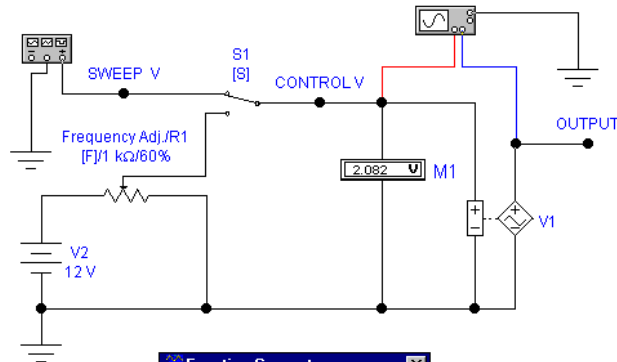

C.19 Voltage-Controlled Piecewise Linear Source

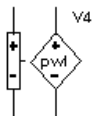

This source (voltage-controlled piecewise linear source) allows you to control the shape of the output waveform by entering up to five (input,output) pairs, which are shown in the Properties dialog box as (X,Y) co-ordinates.

The X values are input co-ordinate points and the associated Y values represent the outputs of those points. If you use only two pairs, the output voltage is linear.

Outside the bounds of the input co-ordinates, the PWL-controlled source extends the slope found between the lowest two co-ordinate pairs and the highest two co-ordinate pairs. A potential effect of this behavior is that it can unrealistically cause the output to reach a very

large or very small value, especially for large input values. Therefore, keep in mind that this source does not inherently provide a limiting capability.

In order to reduce the potential for non-convergence of simulations, the PWL-controlled source provides for smoothing around the co-ordinate pairs. If input smoothing domain (ISD) is set to, say, 10%, the simulator assumes a smoothing radius about each co-ordinate point equal to 10% of the length of the smaller of the segments above and below each co-ordinate point.

C.20 Piecewise Linear Source

C.20.1 The Component

The signal output of this component can be either a current source or a voltage source.

This source allows you to control the shape of the waveform by entering time and voltage/current pairs of values. Each pair of values specifies the value of the source at the specified time. At intermediate values of time, the value of the source is determined by linear interpolation.

The component has two terminals and behaves as a current or voltage source when connected in a circuit. It reads a specified file which contains a table of time and current/voltage points. Using the data in the table, the component generates a current/voltage waveform specified by the input text file.

- To use the PWL source:
 1. Drag PWL Source from the Sources toolbar to the circuit window.
 2. Double-click the component.
 3. Select the file containing the voltage/current and time points from the dialog box. (See “Input Text File Specification” below.)

Outside the bounds of the input co-ordinates, the PWL-controlled source extends the slope found between the lowest two co-ordinate pairs and the highest two co-ordinate pairs. A potential effect of this behavior is that it can unrealistically cause the output to reach a very large or very small value, especially for large input values. Therefore, keep in mind that this source does not inherently provide a limiting capability.

In order to reduce the potential for non-convergence of simulations, the PWL-controlled source provides for smoothing around the co-ordinate pairs. If input smoothing domain (ISD) is set to, say, 10%, the simulator assumes a smoothing radius about each co-ordinate point equal to 10% of the length of the smaller of the segments above and below each co-ordinate point.

C.20.1.1 Example

In the sample circuit shown below, a triangle waveform with uniform rise and fall slopes is modified to a parabolic waveform for which the slope increases at each reference point.

The co-ordinate pairs that perform this conversion are:

| | | |
|-------------|------|-----------------------------------------------------|
| First pair | 0,0 | (no change) |
| Second pair | 1,1 | (same) |
| Third pair | 2,4 | (slope is increased between this pair and the last) |
| Fourth pair | 3,9 | (slope increased again) |
| Fifth | 4,16 | (even steeper slope) |

Note In this example, the Y (output) is the square of the input. It is therefore an exponential.

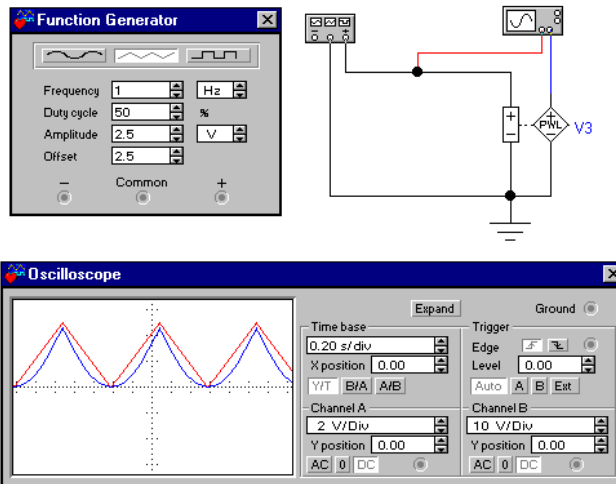

C.20.1.2 Input Text File Specification

This file must contain a list of time and voltage/current points. Each line of the file represents one point. The format is:

Time <space(s)> Voltage

or

Time <space(s)> Current

You can leave any amount of space between the *Time* and *Voltage/Current* fields. Here is an example of an ideally formatted input file:

```

0          0
2.88e-06  0.0181273
5.76e-06  0.0363142
1e-05     0.063185
1.848e-05 0.117198
    
```

| If the PWL source encounters... | It will... |
|---------------------------------------------------------------|--------------------------------------|
| non-whitespace at beginning of line | ignore line |
| non-numeric data following correctly formatted data | accept data, ignore non-numeric data |
| non-whitespace between <i>Time</i> and <i>Voltage/Current</i> | ignore line |
| whitespace preceding correctly formatted data | accept data, ignore whitespace |

Sources

C.20.1.3 Special Considerations

If the earliest input point is not at time 0.0, then the PWL source gives the output of the earliest time point from time 0.0 to that earliest time.

After the latest input point, the PWL source gives the output of the latest time point in the file from that latest time until the simulation ends.

Between input points, the PWL source uses linear interpolation to generate output.

The PWL source can handle unsorted data. It sorts the points by time before the simulation starts.

If you do not specify a file name, the PWL source behaves as a short circuit.

An easy way to generate an input file for the PWL source is to capture data using the Write Data component (described in the Miscellaneous Parts Bin chapter). If you capture more than one node with Write Data and then use the resulting file for the PWL source, only the waveform V1 will be used.

C.20.2 Piecewise Linear Voltage Source



This component is a piecewise linear source of which the output is measured in voltage.

C.20.3 Piecewise Linear Current Source



This component is the same as the Piecewise Linear Voltage Source, except that the output is measured in current.

C.21 Pulse Source

This source includes pulse voltage source and pulse current source. The Pulse sources are configurable sources whose output can be set to produce periodic pulses.

The following parameters can be modified:

- Initial Value
- Pulsed Value
- Delay time
- Rise Time
- Fall time
- Pulse Width
- Period

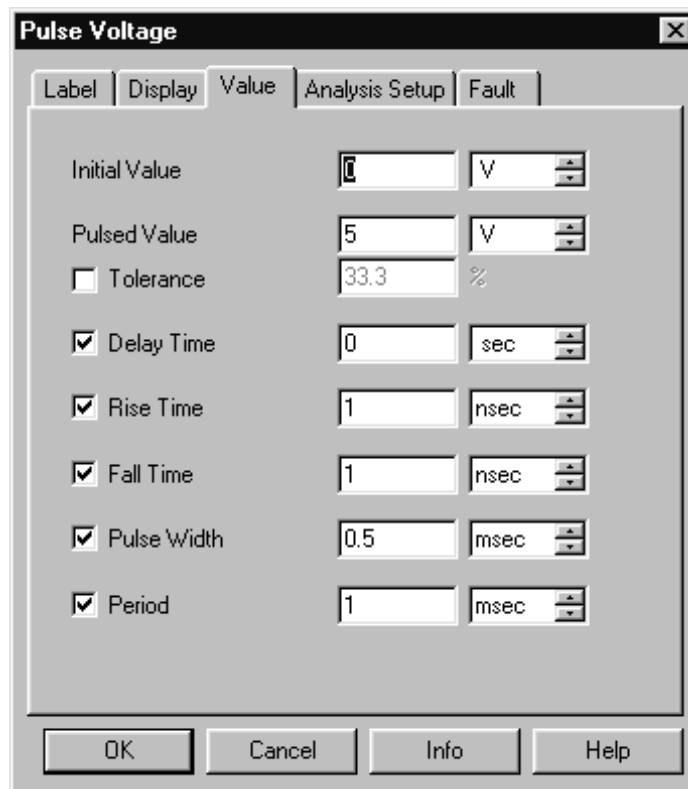

C.21.1 Pulse Voltage Source

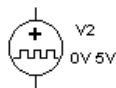

This component is a pulse source of which the the output is measured in voltage.

C.21.2 Pulse Current Source

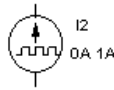

This component is the same as the Pulse Voltage Source, except that the output is measured in current.

C.22 Polynomial Source

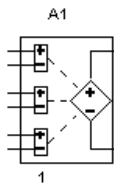

This source is a voltage-controlled voltage source defined by a polynomial transfer function. It is a specific case of the more general nonlinear dependent source. Use it for analog behavioral modeling.

In Multisim, the polynomial source has three controlling voltage inputs, namely, V_1 , V_2 and V_3 .

C.22.1 Output Voltage Characteristic Equation

The output voltage is given by:

$$V_{OUT} = A + B*V_1 + C*V_2 + D*V_3 + E*V_1^2 + F*V_1*V_2 + G*V_1*V_3 + H*V_2^2 + I*V_2*V_3 + J*V_3^2 + K*V_1*V_2*V_3$$

where

- A = constant
- B = coefficient of V_1
- C = coefficient of V_2
- D = coefficient of V_3
- E = coefficient of V_1^2
- F = coefficient of V_1*V_2
- G = coefficient of V_1*V_3
- H = coefficient of V_2^2
- I = coefficient of V_2*V_3

J = coefficient of V_{32}

K = coefficient of $V_1+V_2+V_3$

C.23 Exponential Source

The exponential sources are configurable sources whose output can be set to produce an exponential signal.

The following parameters can be modified:

- Initial Value
- Pulsed Value
- Rise Delay time
- Rise Time
- Fall Delay time
- Fall Time

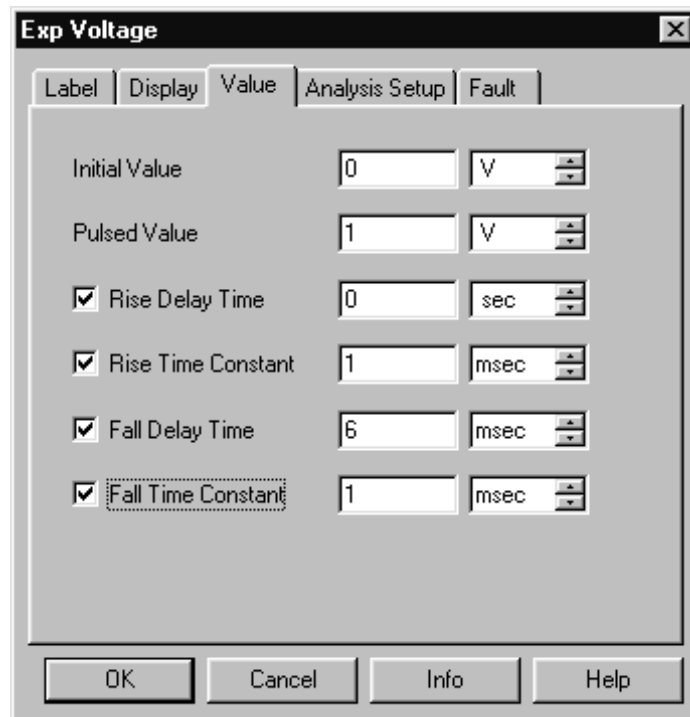

C.23.1 Exponential Voltage Source

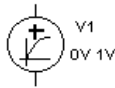

This component is an exponential source of which the output is measured in voltage.

C.23.2 Exponential Current Source

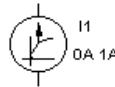

This component is the same as the Exponential Voltage Source, except that the output is measured in current.

C.24 Nonlinear Dependent Source

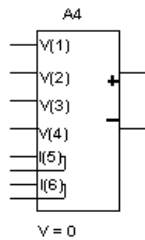

Use this source for analog behavioral modeling. This generic source allows you to create a sophisticated behavioral model by entering a mathematical expression. Expressions may contain the following operators:

+ - * / ^ unary-

and these predefined functions:

| | | | | | |
|-------|-------|-------|-----|------|-------|
| abs | asin | atanh | exp | sin | tan |
| acos | asinh | cos | ln | sinh | u |
| acosh | atan | cosh | log | sqrt | uramp |

The functions u (unit step function) and $uramp$ (integral of unit step) are useful in synthesizing piecewise nonlinear functions.

$$u(x) = \begin{cases} 1 & \text{for } x \geq 0 \\ 0 & \text{for } x < 0 \end{cases}$$

$$uramp(x) = \begin{cases} x & \text{for } x \geq 0 \\ 0 & \text{for } x < 0 \end{cases}$$

If the argument of log, ln or sqrt becomes less than zero, the absolute value of the argument is used. If a divisor becomes zero or the argument of log or ln becomes zero, an error will result. The small-signal AC behavior of this source is a linear dependent source with a proportionality constant equal to the derivative of the source at the DC operating point.

Mathematical expression examples:

$$i = \cos(v(1)) + \sin(v(2))$$

$$v = \ln(\cos(\log(v(1,2))^2)) - v(3)^4 + v(2)^{v(1)}$$

$$i = 17$$

➤ To use the nonlinear dependent source:

1. Double-click the component.
2. Type the algebraic expression.

Note If the dependent variable is “V” the output is in volts; if the dependent variable is “I” the output is current.

C.25 Controlled One-Shot

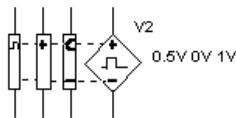

This oscillator takes an AC or DC input voltage, which it uses as the independent variable in the piecewise linear curve described by the (control, pulse width) pairs. From the curve, a pulse width value is determined, and the oscillator outputs a pulse of that width. You can change clock trigger value, output delay from trigger, output delay from pulse width, output rise and fall times, and output high and low values.

When only two co-ordinate pairs are used, the oscillator outputs a linear variation of the pulse with respect to the control input. When the number of co-ordinate pairs is greater than two, the output is piecewise linear.

Sources Components

Sources

Appendix D

Basic Components

| | | |
|-----|-----------------------------------------------------------------|------|
| D.1 | Connectors | D-1 |
| D.2 | Switch | D-1 |
| D.3 | Resistor | D-2 |
| | D.3.1 Resistor: Background Information | D-3 |
| | D.3.2 About Resistance | D-3 |
| | D.3.3 Characteristic Equation | D-4 |
| | D.3.4 Resistor Virtual | D-4 |
| D.4 | Capacitor | D-4 |
| | D.4.1 Capacitor: Background Information | D-5 |
| | D.4.2 Characteristic Equation | D-5 |
| | D.4.3 DC Model | D-5 |
| | D.4.3.1 Time-Domain Model | D-5 |
| | D.4.4 AC Frequency Model | D-7 |
| | D.4.5 Capacitor Virtual | D-7 |
| D.5 | Inductor | D-7 |
| | D.5.1 Inductor: Background Information | D-8 |
| | D.5.2 Characteristic Equation | D-8 |
| | D.5.3 DC Model | D-8 |
| | D.5.4 Time-Domain Model | D-9 |
| | D.5.5 AC Frequency Model | D-10 |
| | D.5.6 Inductor Virtual | D-10 |
| D.6 | Transformer | D-10 |
| | D.6.1 Characteristic Equation | D-11 |
| | D.6.2 Ideal Transformer Model Parameters and Defaults | D-11 |
| D.7 | Nonlinear Transformer | D-12 |
| | D.7.1 Customizing | D-12 |
| | D.7.2 Nonlinear Transformer Parameters and Defaults | D-13 |
| D.8 | Relay | D-13 |
| | D.8.1 Model | D-14 |

| | | |
|--------|-------------------------------------------------|------|
| D.8.2 | Characteristic Equation | D-14 |
| D.9 | Variable Capacitor | D-15 |
| D.9.1 | The Component. | D-15 |
| D.9.2 | Characteristic Equation and Model | D-15 |
| D.9.3 | Virtual Variable Capacitor | D-15 |
| D.10 | Variable Inductor | D-16 |
| D.10.1 | The Component. | D-16 |
| D.10.2 | Characteristic Equation and Model | D-16 |
| D.10.3 | Virtual Variable Inductor | D-16 |
| D.11 | Potentiometer. | D-17 |
| D.11.1 | The Component. | D-17 |
| D.11.2 | Characteristic Equation and Model | D-17 |
| D.11.3 | Virtual Potentiometer. | D-18 |
| D.12 | Pullup. | D-18 |
| D.13 | Resistor Packs | D-18 |
| D.14 | Magnetic Core | D-18 |
| D.14.1 | Characteristic Equation | D-18 |
| D.14.2 | Magnetic Core Parameters and Defaults | D-20 |
| D.15 | Coreless Coil | D-20 |
| D.15.1 | Characteristic Equation | D-21 |
| D.15.2 | Coreless Coil Parameters and Defaults | D-21 |

Appendix D Basic Components

D.1 Connectors

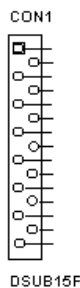

Connectors are mechanical devices used to provide a method of inputting and outputting signals to a design. They do not affect the simulation of the circuit but are included in the circuit for the design of the PCB.

D.2 Switch



The single-pole, double-throw switch can be closed or opened (turned on or off) by pressing a key on the keyboard. You specify the key that controls the switch by typing its name in the Value tab of the Circuit/Component Properties dialog box. For example, if you want the switch to close or open when the spacebar is pressed, type **space** in the Value tab, then click OK.

A list of possible key names is shown below.

| To use... | Type |
|----------------|---------------------|
| letters a to z | the letter (e.g. a) |
| Enter | enter |
| spacebar | space |

D.3 Resistor



Resistors come in a variety of sizes, depending on the power they can safely dissipate. A resistor's resistance, R , is measured in ohms. It can have any value from Ω to $M\Omega$.

The Resistance, R , of a resistor instance is calculated using the following equation:

$$R = R_o * \{ 1 + TC1*(T - T_o) + TC2*[(T-T_o)^2] \}$$

where:

| | | |
|-------|---|-----------------------------------------------------|
| R | = | The resistance of the resistor |
| R_o | = | The resistance of the resistor at temperature T_o |
| T_o | = | Normal temperature = 27 degrees C [CONSTANT] |
| $TC1$ | = | First order temperature coefficient |
| $TC2$ | = | Second order temperature coefficient |
| T | = | Temperature of the resistor |

All of the above variables can be modified, with the exception of T_o , which is a constant.

Note that R_o is the resistance specified on the Value tab of the resistor properties dialog, not 'R'.

T can be specified in two ways:

1. Select the "Use global temperature" option on the Analysis Setup tab of the resistor properties dialog box. Specify the (Global) "Simulation temperature (TEMP)" on the Analysis Options dialog box.
2. Deselect the "Use global temperature" option on the Analysis Setup tab of the resistor properties dialog box. Specify the local temperature of the resistor instance on the Analysis Setup tab of the resistor properties dialog.

The resistor is ideal, with the temperature co-efficient set to zero. To include resistors in the Temperature Analysis, set the temperature co-efficient "TC1 and TC2" in the resistor properties dialog box.

Resistor tolerance is, by default, set to the global tolerance (defined in the Analysis/Monte Carlo dialog box). To set the tolerance explicitly, de-select "Use global tolerance" and enter a value in the "resistance tolerance" field.

D.3.1 Resistor: Background Information

Resistors come in a variety of sizes, related to the power they can safely dissipate. Color-coded stripes on a real-world resistor specify its resistance and tolerance. Larger resistors have these specifications printed on them.

Any electrical wire has resistance, depending on its material, diameter and length. Wires that must conduct very heavy currents (ground wires on lightning rods, for example) have large diameters to reduce resistance.

The power dissipated by a resistive circuit carrying electric current is in the form of heat. Circuits dissipating excessive energy will literally burn up. Practical circuits must take power capacity into account.

D.3.2 About Resistance

Ohm's law states that current flow depends on circuit resistance:

$$I = E/R$$

Circuit resistance can be calculated from the current flow and the voltage:

$$R = E/I$$

Circuit resistance can be increased by connecting resistors in series:

$$R = R1 + R2 + \dots + Rn$$

Circuit resistance can be reduced by placing one resistor in parallel with another:

$$R = \frac{1}{\frac{1}{R1} + \frac{1}{R2} + \frac{1}{R3}}$$

D.3.3 Characteristic Equation

The current through the resistor uses the model:

$$i = \frac{V_1 - V_2}{R}$$

where

| | | |
|-------|---|-------------------|
| i | = | current |
| V_1 | = | voltage at node 1 |
| V_2 | = | voltage at node 2 |
| R | = | resistance |

D.3.4 Resistor Virtual



This component functions in the same way as a resistor, but has a user settable value.

D.4 Capacitor



A capacitor stores electrical energy in the form of an electrostatic field. Capacitors are widely used to filter or remove AC signals from a variety of circuits. In a DC circuit, they can be used to block the flow of direct current while allowing AC signals to pass.

A capacitor's capacity to store energy is called its capacitance, C , which is measured in farads. It can have any value from pF to mF.

Capacitor tolerance is, by default, set to the global tolerance (defined in the Analysis/Monte Carlo dialog box). To set the tolerance explicitly, de-select "Use global tolerance" and enter a value in the "capacitance tolerance" field.

The variable capacitor is simulated as an open circuit with a current across the capacitor forced to zero by a large impedance value.

The polarized capacitor must be connected with the right polarity. Otherwise, an error message will appear. Its capacitance, measured in farads, can be any value from pF to F.

D.4.1 Capacitor: Background Information

Capacitors in an AC circuit behave as “short circuits” to AC signals. They are widely used to filter or remove AC signals from a variety of circuits--AC ripple in DC power supplies, AC noise from computer circuits, etc.

Capacitors prevent the flow of direct current in a DC circuit. They can be used to block the flow of DC, while allowing AC signals to pass. Using capacitors to couple one circuit to another is a common practice.

Capacitors take a predictable time to charge and discharge and can be used in a variety of time-delay circuits. They are similar to inductors and are often used with them for this purpose.

The basic construction of all capacitors involves two metal plates separated by an insulator. Electric current cannot flow through the insulator, so more electrons pile up on one plate than the other. The result is a difference in voltage level from one plate to the other.

D.4.2 Characteristic Equation

The current through the capacitor is equal to C multiplied by the rate of change in voltage across the capacitor, that is:

$$i = C \frac{dv}{dt}$$

D.4.3 DC Model

In the DC model, the capacitor is represented by an open circuit.

D.4.3.1 Time-Domain Model

R_{cn} is an equivalent resistance and i_{cn} is an equivalent current source. The expression for the R_{cn} and i_{cn} depends on the numerical integration method used.

For trapezoid method:

$$R_{cn} = \frac{h}{2C}$$
$$i_{cn} = \frac{2C}{h}V_n + i_n$$

For the first-order Gear method Backward Euler:

$$R_{cn} = \frac{h}{C}$$
$$i_{cn} = \frac{C}{h}V_n$$

where

| | | |
|------------|---|-----------------------------------------------|
| V_{n+1} | = | present unknown voltage across the capacitor |
| i_{n+1} | = | present unknown current through the capacitor |
| V_n, i_n | = | previous solution values |
| h | = | time step |
| n | = | time interval |

These expressions are derived by applying appropriate numerical integration to the characteristic equation of the capacitor.

D.4.4 AC Frequency Model

For the small-signal analysis, the capacitor is modeled by an impedance whose imaginary component is equal to:

$$\frac{1}{2\pi fC}$$

where

| | | |
|---|---|------------------------|
| f | = | frequency of operation |
| C | = | capacitance value |

D.4.5 Capacitor Virtual

 This component performs the same functions as a capacitor, but has a user settable value.

D.5 Inductor

 An inductor stores energy in an electromagnetic field created by changes in current through it. Its ability to oppose a change in current flow is called inductance, L , and is measured in henrys. An inductor can have any value from μH to H.

Inductor tolerance is, by default, set to the global tolerance (defined in the Analysis/Monte Carlo dialog box). To set the tolerance explicitly, de-select “Use global tolerance” and enter a value in the “inductance tolerance” field.

The variable inductor acts exactly like a regular inductor, except that its setting can be adjusted. It is simulated as an open circuit with a current across the inductor forced to zero by a large impedance value. Values are set in the same way as for the potentiometer.

Note This model is ideal. To model a real-world inductor, attach a capacitor and a resistor in parallel with the inductor.

D.5.1 Inductor: Background Information

An inductor is a coil of wire of one “turn” or more. It reacts to being placed in a changing magnetic field by developing an “induced” voltage across the turns of the inductance, and will provide current to a load across the inductance. Voltages can be very large.

Inductors, like capacitors, store energy in magnetic fields. Their “charge” and “discharge” times make them useful in time-delay circuits.

Electric transformers take advantage of the transfer of energy in a magnetic field from the primary winding to the secondary winding, using induced voltage and current. The transfer is proportional to the ratio of the winding turns.

Radio antennae are inductors that operate like transformers in generating and detecting electromagnetic fields. Their efficiency is proportional to their size.

The ignition coil in an automobile develops a very high induced voltage when the current through it suddenly becomes very great. This is the voltage that fires spark plugs.

D.5.2 Characteristic Equation

The voltage across the inductor is equal to the inductance, L , multiplied by the change in current through the inductor, that is:

$$v = L \frac{di}{dt}$$

D.5.3 DC Model

In the DC model, the inductor is represented by a short circuit.

D.5.4 Time-Domain Model

R_{Ln} is an equivalent resistance and i_{Ln} is an equivalent current source. The expression for the R_{Ln} and i_{Ln} depends on the numerical integration method used.

For trapezoid method:

$$R_{Ln} = \frac{2L}{h}$$

$$i_{Ln} = \frac{h}{2L}V_n + i_n$$

For Gear method (first order):

$$R_{Ln} = \frac{L}{h}$$

$$i_{Ln} = \frac{h}{L}V_n$$

where

| | | |
|-------------|---|----------------------------------------------|
| V_{n+1} | = | present unknown voltage across the inductor |
| i_{n+1} | = | present unknown current through the inductor |
| $V_{n, in}$ | = | previous solution values |
| h | = | time step |
| n | = | time interval |

These expressions are derived by applying appropriate numerical integration to the characteristic equation of the inductor.

D.5.5 AC Frequency Model

For the small-signal analysis, the inductor is modeled by an impedance with its imaginary component equal to $2\pi fL$,

where

| | | |
|---|---|---------------------------------------|
| f | = | frequency of operation of the circuit |
| L | = | inductance value |

D.5.6 Inductor Virtual



This component performs in the same way as an inductor, but has a user settable value.

D.6 Transformer

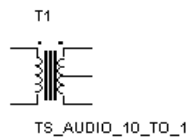

The transformer is one of the most common and useful applications of inductance. It can step up or step down an input primary voltage ($V1$) to a secondary voltage ($V2$). The relationship is given by $V1/V2 = n$, where n is the ratio of the primary turns to the secondary turns. The parameter n can be adjusted by editing the transformer's model.

To properly simulate the transformer, both sides must have a common reference point, which may be ground. The transformer can also be used in a center-tapped configuration. A center-tap is provided which may be used for this purpose. The voltage across the tap is half of the total secondary voltage.

This transformer is suitable for getting quick results. To simulate realistic devices that include a transformer, you should use the nonlinear transformer.

Note Both sides of a transformer must be grounded.

D.6.1 Characteristic Equation

The characteristic equation of an ideal transformer is given by:

$$V_1 = nV_2$$

$$i_1 = \frac{1}{n}i_2$$

where

| | | |
|-------|---|-------------------|
| V_1 | = | primary voltage |
| V_2 | = | secondary voltage |
| n | = | turns ratio |
| i_1 | = | primary current |
| i_2 | = | secondary current |

D.6.2 Ideal Transformer Model Parameters and Defaults

| Symbol | Parameter Name | Default | Unit |
|--------|------------------------------|---------|------|
| n | Turns ratio | 2 | - |
| L_o | Leakage inductance | 0.001 | H |
| L_m | Magnetizing inductance | 5 | H |
| R_p | Primary winding resistance | 0.0 | W |
| R_s | Secondary winding resistance | 0.0 | W |

If $n > 1$, it is a step-down transformer; if $n < 1$, it is a step-up transformer.

D.7 Nonlinear Transformer

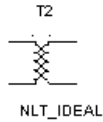

This component is based on a general model that can be customized for different applications.

It is implemented using a conceptual magnetic core and coreless coil building blocks, together with resistors and inductors. Using this transformer, you can model physical effects such as nonlinear magnetic saturation, primary and secondary winding losses, primary and secondary leakage inductances, and core geometric size. See the “Magnetic Core” description for characteristic equations of the magnetic core.

D.7.1 Customizing

The nonlinear transformer can be customized for different applications. It is implemented by using a magnetic core and the coreless coil as the basic building blocks. The magnetic core takes in an input voltage and converts it to a Magnetomotive Force (mmf). The Magnetic Field Intensity (H) is calculated by dividing the mmf by the Length of the core:

$$H = \text{mmf}/L$$

H is then used to find the corresponding Flux Density (B). This is done by using the linear relationship described in the H-B array of coordinate pairs. This H-B array can be taken from the averaging H-B curve, which may be obtained from a technical manual that specifies the magnetic characteristics of different cores.

The slope of the B-H function is never allowed to change abruptly, but is smoothly varied whenever the Input Smoothing domain parameter is set to a number greater than zero.

The Flux Density (B) is multiplied by the cross-sectional area to obtain a Flux Value. The Flux Value is used by the coreless coil to obtain a value for the voltage reflected back across the terminals.

The core is modeled to be lossless. No core losses are considered. In the transformer model, the only losses taken into account are the ones modeled by the winding resistances.

To obtain the H-B points of the curve:

- Contact a manufacturing company. They may be able to provide the technical data required to model a core.
- Obtain experimental data.

D.7.2 Nonlinear Transformer Parameters and Defaults

| Symbol | Parameter Name | Default | Unit |
|--------|------------------------------|---------|-------------------|
| N1 | Primary turns | 1 | - |
| R1 | Primary resistance | 1e-06 | W |
| L1 | Primary leakage inductance | 0.0 | H |
| N2 | Secondary turns | 1 | - |
| R2 | Secondary resistance | 1e-06 | W |
| L2 | Secondary leakage inductance | 0.0 | H |
| A | Cross-sectional area | 1.0 | m ² |
| L | Core length | 1.0 | m |
| ISD | Input smoothing domain | 1.0% | - |
| N | Number of co-ordinates | | 2 |
| H1 | Magnetic field co-ordinate 1 | 0 | A*turns/m |
| H2 | Magnetic field co-ordinate2 | 1.0 | A*turns/m |
| H3-H15 | Magnetic field co-ordinates | 0 | A*turns/m |
| B1 | Flux density co-ordinate 1 | 0 | Wb/m ² |
| B2 | Flux density co-ordinate 2 | 1.0 | Wb/m ² |
| B3-B15 | Flux density co-ordinates | 0 | Wb/m ² |

D.8 Relay

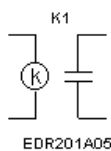

than that of I_{on} .

The magnetic relay can be used as a normally open or normally closed relay. It is activated when the current in the energizing circuit (attached to P_1, P_2) exceeds the value of the switch-on current (I_{on}). During operation, the contact switches from the normally closed terminals (S_1, S_3) to the normally open terminals (S_1, S_2). The relay will remain on as long as the current in the circuit is greater than the holding current (I_{hd}). The value of I_{hd} must be less

The magnetic relay is a coil with a specified inductance (L_c , in henries) that causes a contact to open or close when a specified current (I_{on} , in A) charges it.

The contact remains in the same position until the current falls below the holding value (I_{hd} , in A), at which point it returns to its original position.

D.8.1 Model

The energizing coil of the relay is modeled as an inductor, and the relay's switching contact is modeled as resistors R_1 and R_2 .

D.8.2 Characteristic Equation

$$\begin{aligned}
 R_1 &= 0 \\
 R_2 &= \bullet && \text{if } i_p \leq i_{on} \\
 R_1 &= \bullet \\
 R_2 &= 0 && \text{if } i_{hd} < i_{on} \leq i_p
 \end{aligned}$$

where

- L = inductance of the relay energizing coil, in henrys
- R_1, R_2 = resistance of the relay's switching contact, in ohms
- i_{on} = turn-on current, in amperes
- i_{hd} = holding current, in amperes
- i_p = current through the energizing coil in amperes

D.9 Variable Capacitor

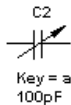

D.9.1 The Component

This component acts much like a regular capacitor, except that its setting can be adjusted.

D.9.2 Characteristic Equation and Model

This component's capacitance, C , is computed based on the initial settings according to the equation:

$$C = \frac{\textit{Setting}}{100} * \textit{Capacitance}$$

The variable capacitor is simulated as an open circuit with a current across the capacitor forced to zero by a large impedance value.

Values are set in the same way as those for the potentiometer.

D.9.3 Virtual Variable Capacitor

This component performs the same functions as a variable capacitor, but has a user settable value.

D.10 Variable Inductor

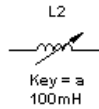

D.10.1 The Component

This component acts much like a regular inductor, except that its setting can be adjusted.

D.10.2 Characteristic Equation and Model

This component's inductance, L , is computed based on the initial settings according to the equation:

$$L = \frac{\textit{Setting}}{100} * \textit{Inductance}$$

The variable inductor is simulated as an open circuit with a current across the inductor forced to zero by a large impedance value.

Values are set in the same way as for the potentiometer.

D.10.3 Virtual Variable Inductor

This component performs the same functions as a variable inductor, but has a user settable value.

D.11 Potentiometer

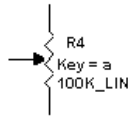

D.11.1 The Component

This component acts much like a regular resistor, except that you can, with a single keystroke, adjust its setting. In the Value tab of the Circuit/Component Properties dialog box, you set the potentiometer's resistance, initial setting (as a percentage) and increment (as a percentage). You also identify the key (A to Z) that you will use to control the setting.

- To decrease the potentiometer's setting, press the identified key.
- To increase the setting, press and hold SHIFT and press the identified key.

For example, say the potentiometer is set to 45%, the increment is 5% and the key is R. You press R, and the setting drops to 40%. You press R again, and it drops to 35%. You press SHIFT and R, and the setting rises to 40%.

D.11.2 Characteristic Equation and Model

The potentiometer is simulated using two resistors, R_1 and R_2 , whose values are computed using the potentiometer's initial settings.

$$r = \frac{\text{Setting}}{100} * \text{Resistance}$$

where

$$\begin{aligned} R_1 &= r \\ R_2 &= \text{Resistance} - r \end{aligned}$$

D.11.3 Virtual Potentiometer

This component performs the same functions as a potentiometer, but has a user settable value.

D.12 Pullup

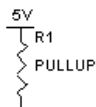

This component is used to raise the voltage of a circuit to which it is connected. One end is connected to Vcc. The other end is connected to a point in a logic circuit that needs to be raised to a voltage level closer to Vcc.

D.13 Resistor Packs

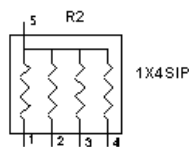

Resistor packs are collections of resistors within a single package. The configuration of the resistors can be varied based on the intended usage of the package. Resistor packs are used to minimize the amount of space required on the PCB for the design. In some applications, noise can be a consideration for the use of resistor packs.

D.14 Magnetic Core

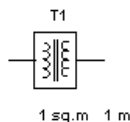

This component is a conceptual model that you can use as a building block to create a wide variety of inductive and magnetic circuit models. Typically, you would use the magnetic core together with the coreless coil to build up systems that mock the behavior of linear and nonlinear magnetic components. It takes as input a voltage which it treats as a magnetomotive force (mmf) value.

D.14.1 Characteristic Equation

Magnetic field intensity, H, is:

$$H = mmf / l$$

where

$$mmf = \text{magnetomotive force, the input voltage}$$

l = core length

Flux density, B , is derived from a piecewise linear transfer function described to the model by the (magnetic field, flux density) pairs that you input in the Circuit/Component Properties dialog box. The final current, I , allowed to flow through the core is used to obtain a value for the voltage reflected back across the terminals. It is calculated as:

$$I = BA$$

where

A = cross-sectional area

D.14.2 Magnetic Core Parameters and Defaults

| Symbol | Parameter Name | Default | Unit |
|---------------|------------------------------|---------|-------------------|
| <i>A</i> | Cross-sectional area | 1 | m ² |
| <i>L</i> | Core length | 1 | m |
| <i>ISD</i> | Input smoothing domain% | 1 | - |
| <i>N</i> | Number of co-ordinates | 2 | - |
| <i>H1</i> | Magnetic field co-ordinate 1 | 0 | A.turns/m |
| <i>H2</i> | Magnetic field co-ordinate 2 | 1.0 | A.turns/m |
| <i>H3-H15</i> | Magnetic field co-ordinates | 0 | A.turns/m |
| <i>B1</i> | Flux density co-ordinate 1 | 0 | Wb/m ² |
| <i>B2</i> | Flux density co-ordinate 2 | 1.0 | Wb/m ² |
| <i>B3-B15</i> | Flux density co-ordinates | 0 | Wb/m ² |

D.15 Coreless Coil



This component is a conceptual model that you can use as a building block to create a wide variety of inductive and magnetic circuit models. Typically, you would use the coreless coil together with the magnetic core to build up systems that mock the behavior of linear and nonlinear magnetic components. It takes as input a current and produces a voltage.

The output voltage behaves like a magnetomotive force in a magnetic circuit, that is, when the coreless coil is connected to the magnetic core or some other resistive device, a current flows.

D.15.1 Characteristic Equation

$$V_{out} = N * i_{in}$$

where

V_{out} = output voltage value (magnetomotive force)

i_{in} = input current

D.15.2 Coreless Coil Parameters and Defaults

| Symbol | Parameter Name | Default | Unit |
|--------|--------------------------|---------|------|
| N | Number of inductor turns | 1 | - |

Appendix E

Diodes Components

| | | |
|-------|----------------------------------------------------|------|
| E.1 | Diode | E-1 |
| E.1.1 | Diodes: Background Information | E-1 |
| E.1.2 | DC Model | E-2 |
| E.1.3 | Time-Domain Model | E-3 |
| E.1.4 | AC Small-Signal Model | E-4 |
| E.1.5 | Diode Parameters and Defaults | E-5 |
| E.2 | Pin Diode | E-6 |
| E.2.1 | Photo Diode Application | E-6 |
| E.3 | Zener Diode | E-6 |
| E.3.1 | DC Model | E-7 |
| E.3.2 | Zener Diode Parameters and Defaults | E-8 |
| E.4 | LED (Light-Emitting Diode) | E-8 |
| E.4.1 | Background Information | E-9 |
| E.4.2 | LED Parameters and Defaults | E-9 |
| E.5 | Full-Wave Bridge Rectifier | E-10 |
| E.5.1 | Characteristic Equation | E-10 |
| E.5.2 | Model | E-10 |
| E.5.3 | Full-Wave Bridge Rectifier Parameters and Defaults | E-11 |
| E.6 | Schottky Diode | E-12 |
| E.7 | Silicon-Controlled Rectifier | E-12 |
| E.7.1 | Model | E-13 |
| E.7.2 | Time-Domain Model | E-13 |
| E.7.3 | AC Small-Signal Model | E-14 |
| E.7.4 | SCR Parameters and Defaults | E-14 |
| E.8 | DIAC | E-14 |
| E.8.1 | DC Model | E-15 |
| E.8.2 | Time-Domain and AC Small-Signal Models | E-15 |
| E.8.3 | DIAC Parameters and Defaults | E-16 |

| | | |
|------|----------------------|------|
| E.9 | TRIAC | E-16 |
| | E.9.1 Model | E-16 |
| E.10 | Varactor Diode | E-18 |

Appendix E

Diodes Components

E.1 Diode



Diodes allow current to flow in only one direction and can therefore be used as simple solid-state switches in AC circuits, being either open (not conducting) or closed (conducting). Terminal A is called the anode and terminal K is called the cathode.

E.1.1 Diodes: Background Information

Diodes exhibit a number of useful characteristics, such as predictable capacitance (that can be voltage controlled) and a region of very stable voltage. They can, therefore, be used as switching devices, voltage-controlled capacitors (varactors) and voltage references (Zener diodes).

Because diodes will conduct current easily in only one direction, they are used extensively as power rectifiers, converting AC signals to pulsating DC signals, for both power applications and radio receivers.

Diodes behave as voltage-controlled switches, and have replaced mechanical switches and relays in many applications requiring remote signal switching.

Even indicator lamps are now replaced with diodes (LEDs) that emit light in a variety of colors when conducting.

A special form of diode, called a Zener diode, is useful for voltage regulation.

E.1.2 DC Model

The DC characteristic of a real diode in Multisim is divided into the forward and reverse characteristics.

DC forward characteristic:

$$I_D = I_S \left(e^{\frac{V_D}{nV_T}} - 1 \right) + V_D * G_{\min} \quad \text{for } V_D \geq -5nV_T$$

DC reverse characteristic:

$$I_D = \begin{cases} I_S \left(e^{\frac{V_D}{nV_T}} - 1 \right) + V_D * G_{\min} & \text{for } -5nV_T \leq V_D \leq 0 \\ -I_S + V_D * G_{\min} & \text{for } -BV < V_D < -5nV_T \\ -IBV & \text{for } V_D = -BV \\ -I_S \left(e^{-\left(\frac{BV+V_D}{V_T}\right)} - 1 + \frac{BV}{V_T} \right) & \text{for } V_D < -BV \end{cases}$$

where

| | | |
|-------|---|-------------------------------------------------------------|
| I_D | = | current through the diode, in amperes |
| V_D | = | voltage across the diode, in volts |
| V_T | = | thermal voltage (= 0.0258 volts at room temperature (27°C)) |
| BV | = | breakdown voltage |

I_S is equivalent to the reverse saturation current (I_o) of a diode. In a real diode, I_S doubles for every 10-degree rise in temperature.

Other symbols used in these equations are defined in ‘Diode Parameters and Defaults’.

E.1.3 Time-Domain Model

This model defines the operation of the diode, taking into account its charge-storage effects or capacitance. There are two types of capacitances: diffusion or storage capacitance, and depletion or junction capacitance.

The charge-storage element, C_D , takes into account both of these as follows:

$$C_D = \begin{cases} \tau_t \frac{dI_D}{dV_D} + C_{j0} \left(1 - \frac{V_D}{\phi_0}\right)^{-m} & \text{for } V_D < FC * j_0 \\ \tau_t \frac{dI_D}{dV_D} + \frac{C_{j0}}{F_2} \left(F_3 + \frac{mV_D}{\phi_0}\right) & \text{for } V_D \geq FC * j_0 \end{cases}$$

where

| | | |
|----------|---|----------------------------------------------------------------|
| C_{j0} | = | zero-bias junction capacitance; typically 0.1 to 10 picofarads |
| ϕ_0 | = | junction potential; typically 0.5 to 0.7 volts |
| τ_t | = | transit time; typically 1 nanosecond |
| m | = | junction grading coefficient; typically 0.33 to 0.5 |

and where F_2 and F_3 are constants whose values are:

$$F_2 = (1 - FC)^{1+m}$$

$$F_3 = 1 - FC(1 + m)$$

Notes

3. The voltage drop across the diode varies depending on the set value of:

| | | |
|-------|---|---------------------------------------------|
| I_S | = | saturation current; typically 10-14 amperes |
| r_S | = | ohmic resistance; typically 0.05 ohms. |

4. The parameter τ_t is proportional to the reverse recovery time of the diode. That is, it affects the turn-off or switching speed of the diode. It is the time required for the minority carrier to cross the junction.

- The barrier potential for a diode is approximately 0.7 to 0.8 volts. This is not to be confused with the model parameter ϕ_0 given above.

E.1.4 AC Small-Signal Model

The figure below shows the linearized, small-signal diode model, in which the diode is represented by a small-signal conductance, g_D . The small-signal capacitance is also evaluated at the DC operating point.

$$g_D = \left. \frac{dI_D}{dV_D} \right|_{OP} = \frac{I_S}{nV_T} e^{\frac{V_D}{nV_T}}$$

$$C_D = \left. \frac{dQ_D}{dV_D} \right|_{OP} = \begin{cases} \tau_t * g_D + C_{j0} \left(1 - \frac{V_D}{\phi_0} \right)^{-m} & \text{for } V_D < FC * j_0 \\ \tau_t * g_D + \frac{C_{j0}}{F_2} \left(F_3 + \frac{mV_D}{\phi_0} \right) & \text{for } V_D \geq FC * j_0 \end{cases}$$

where

- OP = operating point
- Q_D = the charge on C_D

E.1.5 Diode Parameters and Defaults

| Symbol | Parameter Name | Default | Typical Value | Unit |
|--------|------------------------------------------------------------|---------|--------------------------|------|
| IS | Saturation current | 1e-14 | 1e-9 - 1e-18 cannot be 0 | A |
| RS | Ohmic resistance | 0 | 10 | W |
| CJO | Zero-bias junction capacitance | 0 | 0.01-10e-12 | F |
| VJ | Junction potential | 1 | 0.05-0.7 | V |
| TT | Transit time | 0 | 1.0e-10 | s |
| M | Grading coefficient | 0.5 | 0.33-0.5 | - |
| Symbol | Parameter Name | Default | Typical Value | Unit |
| BV | Reverse bias breakdown voltage | 1e+30 | - | V |
| N | Emission coefficient | 1 | 1 | - |
| EG | Activation energy | 1.11 | 1.11 | eV |
| XTI | Temperature exponent for effect on IS | 3.0 | 3.0 | - |
| KF | Flicker noise coefficient | 0 | 0 | - |
| AF | Flicker noise exponent | 1 | 1 | - |
| FC | Coefficient for forward-bias depletion capacitance formula | 0.5 | 0.5 | - |
| IBV | Current at reverse breakdown voltage | 0.001 | 1.0e-03 | A |
| TNOM | Parameter measurement temperature | 27 | 27-50 | °C |

E.2 Pin Diode



The PIN diode consists of three semiconductor materials.

The center material is made up of intrinsic (pure) silicon. The *p*- and *n*-type materials are heavily doped and, as a result, have very low resistances.

When reverse biased, the PIN diode acts as a capacitor. The intrinsic material can be seen as the dielectric of a capacitor. The heavily doped *p*- and *n*-type materials can be viewed as the two conductors.

E.2.1 Photo Diode Application

The intrinsic layer, which is a pure semiconductor with no impurities, makes the PIN diode respond better to infrared photons that penetrate deeper into the diode's regions.

The intrinsic layer creates a larger depletion region, which causes the diode to produce a more linear change in current in response to changes in light intensity.

E.3 Zener Diode

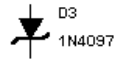

A zener diode is designed to operate in the reverse breakdown, or Zener, region, beyond the peak inverse voltage rating of normal diodes. This reverse breakdown voltage is called the Zener test voltage (V_{zt}), which can range between 2.4 V and 200 V.

In the forward region, it starts conducting around 0.7 V, just like an ordinary silicon diode. In the leakage region, between zero and breakdown, it has only a small reverse current. The breakdown has a sharp knee, followed by an almost vertical increase in current.

Zener diodes are used primarily for voltage regulation because they maintain constant output voltage despite changes in current.

E.3.1 DC Model

The DC characteristic of a real diode in Multisim is divided into the forward and reverse characteristics.

DC forward characteristic:

$$I_D = I_S \left(e^{\frac{V_D}{nV_T}} - 1 \right) + V_D * G_{\min} \quad \text{for } V_D \geq -5nV_T$$

DC reverse characteristic:

$$I_D = \begin{cases} I_S \left(e^{\frac{V_D}{nV_T}} - 1 \right) + V_D * G_{\min} & \text{for } -5nV_T \leq V_D \leq 0 \\ -I_S + V_D * G_{\min} & \text{for } -BV < V_D < -5nV_T \\ -IBV & \text{for } V_D = -BV \\ -I_S \left(e^{-\left(\frac{BV+V_D}{V_T}\right)} - 1 + \frac{BV}{V_T} \right) & \text{for } V_D < -BV \end{cases}$$

where

| | | |
|-------|---|-------------------------------------------------------------|
| I_D | = | current through the diode in amperes |
| V_D | = | voltage across the diode in volts |
| V_T | = | thermal voltage (= 0.0258 volts at room temperature (27°C)) |
| BV | = | breakdown voltage |

I_S is equivalent to the reverse saturation current (I_o) of a diode. In a real diode, I_S doubles for every 10-degree rise in temperature.

Other symbols used in these equations are defined in the table below.

E.3.2 Zener Diode Parameters and Defaults

| Symbol | Parameter name | Default | Unit |
|--------|------------------------------------------------------------|---------|------|
| Is | Saturation current | 1e-14 | A |
| Rs | Ohmic resistance | 0 | W |
| CJO | Zero-bias junction capacitance | 0 | F |
| VJ | Junction potential | 1 | V |
| TT | Transit time | 0 | S |
| M | Grading coefficient | 0.5 | - |
| VZT | Zener test voltage | 1e+30 | V |
| IZT | Zener test current | 0.001 | A |
| N | Emission coefficient | 1 | - |
| EG | Activation energy | 1.11 | eV |
| XTI | Temperature exponent for effect on Is | 3.0 | - |
| Symbol | Parameter name | Default | Unit |
| KF | Flicker noise coefficient | 0 | - |
| AF | Flicker noise exponent | 1 | - |
| FC | Coefficient for forward-bias depletion capacitance formula | 0.5 | - |
| TNOM | Parameter measurement temperature | 27 | °C |

E.4 LED (Light-Emitting Diode)

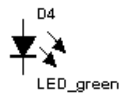

This diode emits visible light when forward current through it, I_f , exceeds the turn-on current, I_{on} . The electrical model of the LED is the same as the diode model described previously.

LEDs are used in the field of optoelectronics. Infrared devices are used together with spectrally matched phototransistors in optoisolation couplers, hand-held remote

controllers, and in fiber-optic sensing techniques. Visible spectrum applications include status indicators and dynamic power level bar graphs on a stereo system or tape deck.

E.4.1 Background Information

LEDs are constructed of gallium arsenide or gallium arsenide phosphide. While efficiency can be obtained when conducting as little as 2 milliamperes of current, the usual design goal is in the vicinity of 10 mA. During conduction, there is a voltage drop across the diode of about 2 volts.

Most early information display devices required power supplies in excess of 100 volts. The LED ushered in an era of information display components with sizes and operating voltages compatible with solid-state electronics. Until the low-power liquid-crystal display was developed, LED displays were common, despite high current demands, in battery-powered instruments, calculators and watches. They are still commonly used as on-board annunciators, displays and solid-state indicator lamps.

E.4.2 LED Parameters and Defaults

| Symbol | Parameter Name | Default | Unit |
|--------|--------------------------------|---------|------|
| IS | Saturation current | 1e-14 | A |
| RS | Ohmic resistance | 0 | W |
| CJO | Zero-bias junction capacitance | 0 | F |
| VJ | Junction potential | 1 | V |
| TT | Transit time | 0 | s |
| M | Grading coefficient | 0.5 | - |

E.5 Full-Wave Bridge Rectifier

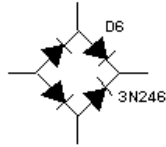

The full-wave bridge rectifier uses four diodes to perform full-wave rectification of an input AC voltage. Two diodes conduct during each half cycle, giving a full-wave rectified output voltage. The top and bottom terminals can be used as the input terminals for the AC voltage. The left and right terminals can be used as the output DC terminals.

E.5.1 Characteristic Equation

The average output DC voltage at no load condition is approximately given by:

$$V_{DC} = 0.636 * (V_p - 1.4)$$

where

$$V_p = \text{the peak value of the input AC voltage}$$

E.5.2 Model

A full-wave bridge rectifier consists of four diodes as shown in its icon.

Terminals 1 and 2 are the input terminals, so the input AC source is connected across 1 and 2. Terminals 3 and 4 are the output terminals, so the load is connected across 3 and 4.

When the input cycle is positive, diodes D_1 and D_2 are forward-biased and D_3 and D_4 are reverse-biased. D_1 and D_2 thus conduct current in the direction shown. The voltage developed is identical to the positive half of the input sine wave minus the diode drops.

When the input cycle is negative, diodes D_3 and D_4 become forward-biased and conduct current in the direction shown. Hence, the current flows in the same direction for both the positive and the negative halves of the input wave. A full-wave rectified voltage appears across the load.

E.5.3 Full-Wave Bridge Rectifier Parameters and Defaults

| Symbol | Parameter Name | Default | Typical Value | Unit |
|--------|------------------------------------------------------------|---------|--------------------------|------|
| IS | Saturation current | 1e-14 | 1e-9 - 1e-18 cannot be 0 | A |
| RS | Ohmic resistance | 0 | 10 | W |
| CJO | Zero-bias junction capacitance | 0 | 0.01-10e-12 | F |
| VJ | Junction potential | 1 | 0.05-0.7 | V |
| TT | Transit time | 0 | 1.0e-10 | s |
| M | Grading coefficient | 0.5 | 0.33-0.5 | - |
| BV | Reverse bias breakdown voltage | 1e+30 | - | V |
| N | Emission coefficient | 1 | 1 | - |
| EG | Activation energy | 1.11 | 1.11 | eV |
| XTI | Temperature exponent for effect on <i>IS</i> | 3.0 | 3.0 | - |
| KF | Flicker noise coefficient | 0 | 0 | - |
| AF | Flicker noise exponent | 1 | 1 | - |
| FC | Coefficient for forward-bias depletion capacitance formula | 0.5 | 0.5 | - |
| IBV | Current at reverse breakdown voltage | 0.001 | 1.0e-03 | A |
| TNOM | Parameter measurement temperature | 27 | 27-50 | °C |

E.6 Schottky Diode



The Schottky diode is a two-terminal device with a junction that uses metal in place of the p -type material. The formation of a junction with a semiconductor and metal results in very little junction capacitance.

The Schottky diode will have a V_F of approximately 0.3 V and a V_{BR} of less than -50 V. These are lower than the typical pn -junction ratings of $V_F = 0.7$ V and $V_{BR} = -150$ V.

With very little junction capacitance, the Schottky diode can be operated at much higher frequencies than the typical pn -junction diode and has a much faster switching time.

The Schottky diode is a relatively high-current device that is capable of switching rapidly while providing forward currents of approximately 50 A. It can operate at frequencies of 20 GHz and higher in sinusoidal and low-current switching circuits.

E.7 Silicon-Controlled Rectifier



A silicon-controlled rectifier (SCR) is a unidirectional current control device like a Shockley diode. However, the SCR has a third terminal capable of supporting a digital gate connection, which adds another means of controlling the current flow. The SCR switches on when the forward bias voltage exceeds the forward-breakover voltage or when a current pulse is applied to the gate terminal.

The SCR is triggered into conduction by applying a gate-cathode voltage (V_{GK}), which causes a specific level of gate current (I_G). The gate current triggers the SCR into conduction. The device is returned to its nonconducting state by either anode current interruption or forced commutation. When the SCR is turned off, it stays in a non-conducting state until it receives another trigger.

E.7.1 Model

The SCR is simulated using a mixed electrical and behavioral model.

The status of the SCR is handled with a logical variable, much like the Shockley diode and diac simulations. The resistance, R_s , acts as a current block when the SCR is switched off. R_s has two separate values, depending on the status of the SCR. When the SCR is on, the resistance R_s is low; when the SCR is off, the resistance R_s is high. The high resistance value acts as a current block.

The SCR is switched on and R_s set low ($1e-06$) if:

$$V_d \geq V_{drm}$$

or

$$I_g \geq I_{gt} \text{ at } V_g \geq V_{gt} \text{ and}$$

$$V_d \geq 0$$

or

$$\frac{dV_d}{dt} \geq \frac{dV}{dt} \text{ of the SCR}$$

The SCR is switched off and R_s set high if:

$$I_d < I_h$$

In this case, the switching occurs after turn-off time T_q , which is implemented by the behavioral controller

I_d = current through the SCR, in amperes

r_s = blocking resistance, in ohms

Symbols used in these equations are defined in “SCR Parameters and Defaults”.

E.7.2 Time-Domain Model

For the time-domain model, the charge-storage effects of the SCR junction capacitance are considered in the simulation.

The turn-off time, T_q , is implemented by introducing a behavioral delay in the opening of the controlled switch.

E.7.3 AC Small-Signal Model

In the AC model, the diode is represented by its linearized small-signal model. The diode small-signal conductance g_d and the small-signal capacitance C_d are evaluated at the DC operating point.

E.7.4 SCR Parameters and Defaults

| Symbol | Parameter Name | Default | Unit |
|-----------------|------------------------------------------------------|---------|------------|
| Irdm | Peak off-state current | 1e-06 | A |
| Vdrm | Forward breakover voltage | 200 | V |
| Vtm | Peak on-state voltage | 1.5 | V |
| I _{tm} | Forward current at which V _{tm} is measured | 1 | A |
| T _q | Turn-off time | 1.5e-05 | s |
| dv/dt | Critical rate of off-state voltage rise | 50 | V/ μ s |
| I _h | Holding current | 0.02 | A |
| V _{gt} | Gate trigger voltage | 1 | V |
| I _{gt} | Gate trigger current | 0.001 | A |
| V _d | Voltage at which I _{gt} is measured | 10 | V |

E.8 DIAC



A diac is a two-terminal parallel-inverse combination of semiconductor layers that allows triggering in either direction. It functions like two parallel Shockley diodes aligned back-to-back. The diac restricts current flow in both directions until the voltage across the diac exceeds the switching voltage. Then the diac conducts current in the direction of the voltage.

E.8.1 DC Model

The diac is switched on and the resistance, R_s , is set low if, in either the positive or negative direction.

$$V_d \geq V_s$$

The diac is switched off (current-blocking mode) and R_s is set high $\frac{V_s}{I_{rev}}$ if, in either direction:

$$I_d < I_h$$

where

V_d = voltage across the diac, in volts

I_d = current through the diac, in amperes

R_s = blocking resistance

I_{rev} = peak off-state reverse current

Other symbols used in these equations are defined in “Diac Parameters and Defaults”.

E.8.2 Time-Domain and AC Small-Signal Models

Each of the Shockley diodes is simulated with the mixed electrical/behavioral model described in the DC model above.

E.8.3 DIAC Parameters and Defaults

| Symbol | Parameter Name | Default | Unit |
|-----------------|------------------------------------------------------|---------|------|
| IS | Saturation current | 1e-06 | A |
| Vs | Switching voltage | 100 | V |
| Vtm | Peak on-state voltage | 1.5 | V |
| I _{tm} | Forward current at which V _{tm} is measured | 1 | A |
| Tq | Turn-off time | 1e-06 | s |
| I _h | Holding current | 0.02 | A |
| CJO | Zero-bias junction capacitance | 1e-12 | F |

E.9 TRIAC

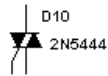

A triac is a three-terminal five-layer switch capable of conducting current in both directions. The triac model consists of two SCRs, each of which is modeled as described earlier in this chapter. The triac remains off, restricting current in both directions until the voltage across the triac exceeds the breakover voltage, or until a positive pulse of current is applied to the gate terminal.

E.9.1 Model

The simulation is a combined electrical/behavioral model. The status of the triac, either on or off, is treated as a logical variable. The resistance, R_s , is a function of the triac status.

When the triac is off, the resistance R_s is set high $\left(\frac{V_{drm}}{I_{drm}}\right)$ to act as a current block. When the triac is on, R_s is low ($1e-06$).

The triac is switched on in either direction if:

$$V_d \geq V_{drm}$$

$$R_s = 1e - 06$$

or

$$V_d \geq 0 \text{ and}$$

$$I_g \geq I_{gt} \text{ at } V_g \geq V_{gt}$$

or

$$\frac{dV_d}{dt} \geq \frac{dV}{dt} \text{ of the triac}$$

The triac is switched off and the resistance R_s is set high (current-blocking mode) if:

$$I_d < I_h.$$

In this case the switching occurs after turn-off time T_q , which is implemented by the behavioral controller.

| | | |
|-----------|---|-------------------------------------------------------------------|
| V_s | = | maximum forward breakover voltage, or switching voltage, in volts |
| I_d | = | current through the diac, in amperes |
| R_s | = | blocking resistance, in ohms |
| I_{rev} | = | peak off-state reverse current |
| V_{br} | = | maximum forward breakover voltage, in volts |
| i_d | = | current through the triac, in amperes |
| V_d | = | voltage across the diac, in volts |
| vd | = | voltage across the triac, in volts |
| t_d | = | turn-on time, in seconds |

Other symbols used in these equations are defined in “Triac Parameters and Defaults”.

E.10 Varactor Diode



The varactor is a type of pn -junction diode with relatively high junction capacitance when reverse biased. The capacitance of the junction is controlled by the amount of reverse voltage applied to the device, which makes the device function as a voltage-controlled capacitor.

The capacitance of a reverse-biased varactor junction is found in the following way:

$$C_T = \epsilon \frac{A}{W_d}$$

where

| | | |
|------------|---|--------------------------------------------|
| C_T | = | the total junction capacitance |
| ϵ | = | permittivity of the semiconductor material |
| A | = | the cross-sectional area of the junction |
| W_d | = | the width of the depletion layer |

The value of C_T is inversely proportional to the width of the depletion layer. The depletion layer acts as an insulator (called the dielectric) between the p -type and n -type materials.

Varactor diodes are used in place of variable capacitors in many applications.

Appendix F

Transistors Components

| | | |
|-----|------------------------------------------------------------------|------|
| F.1 | BJT (NPN & PNP) | F-1 |
| | F.1.1 Characteristic Equations | F-2 |
| | F.1.2 Time-Domain Model | F-4 |
| | F.1.3 AC Small-Signal Model | F-5 |
| | F.1.4 BJT Model Parameters and Defaults | F-6 |
| F.2 | Resistor Biased BJT (NPN & PNP) | F-8 |
| F.3 | Darlington Transistor (NPN & PNP) | F-8 |
| | F.3.1 DC Bias Model | F-8 |
| | F.3.2 AC Model | F-9 |
| | F.3.2.1 AC Input Impedance | F-9 |
| | F.3.2.2 AC Current Gain | F-9 |
| F.4 | BJT Array | F-9 |
| | F.4.1 General-purpose PNP Transistor Array | F-10 |
| | F.4.2 NPN/PNP Transistor Array | F-10 |
| | F.4.3 General-purpose High-current NPN Transistor Array. | F-10 |
| F.5 | MOSFET | F-10 |
| | F.5.1 Depletion MOSFETs | F-11 |
| | F.5.2 Enhancement MOSFETs | F-11 |
| | F.5.3 DC Model | F-12 |
| | F.5.4 Time-Domain Model | F-13 |
| | F.5.5 AC Small-Signal Model | F-13 |
| | F.5.6 MOSFET Level 1 Model Parameters and Defaults | F-14 |
| F.6 | JFETs (Junction FETs) | F-15 |
| | F.6.1 DC Model | F-16 |
| | F.6.2 JFET Model Parameters and Defaults | F-18 |
| F.7 | Power MOSFET (N/P) | F-19 |
| F.8 | N-Channel & P-Channel GaAsFET | F-19 |
| | F.8.1 Model and Characteristic Equations. | F-19 |
| | F.8.2 GaAsFET Parameters and Defaults. | F-21 |

F.9 IGBT F-21

Appendix F Transistors Components

F.1 BJT (NPN & PNP)

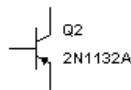

A bipolar junction transistor, or BJT, is a current-based valve used for controlling electronic current. BJTs are operated in three different modes, depending on which element is common to input and output: common base, common emitter or common collector. The three modes have different input and output impedances and different current gains, offering individual advantages to a designer.

A transistor can be operated in its nonlinear region as a current/voltage amplifier or as an electronic switch in cutoff and saturation modes. In its linear region, it must be biased appropriately (i.e., subjected to external voltages to produce a desired collector current) to establish a proper DC operating point. The transistors' parameters are based on the Gummel-Poon transistor model.

BJTs are commonly used in amplification and switching applications. They come in two versions: NPN and PNP. The letters refer to the polarities, positive or negative, of the materials that make up the transistor sandwich. For both NPNs and PNPs, the terminal with the arrowhead represents the emitter.

An NPN transistor has two n-regions (collector and emitter) separated by a p-region (base). The terminal with the arrowhead is the emitter. The ideal NPN in the parts bin has generic values suitable for most circuits. You can specify a real-world transistor by double-clicking the icon and choosing another model.

A PNP transistor has two p-regions (collector and emitter) separated by an n-region (base). The terminal with the arrowhead represents the emitter. The ideal PNP model has generic values suitable for most circuits. You can specify a real-world transistor by double-clicking the icon and choosing another model.

F.1.1 Characteristic Equations

$$I_E = I_C + I_B$$

$$\beta_{DC} = \frac{I_C}{I_B} = h_{FE}$$

$$\beta_{AC} = \frac{\Delta I_C}{\Delta I_B} = \left| OP(V_{CE}) \right| = h_{fe}$$

where

β_{DC} = h_{FE} = DC current gain

β_{AC} = h_{fe} = small-signal current gain

I_C = collector current

I_B = base current

ΔI_E = emitter current

The model for the PNP transistor is the same as the NPN model, except the polarities of the terminal currents and voltages are reversed.

The DC characteristic of a BJT in Multisim is modeled by a simplified Gummel-Poon model. The base-collector and base-emitter junctions are described by their ideal diode equations. The diode capacitors are treated as open circuits.

The beta variation with current is modeled by two extra non-ideal diodes. The diode capacitors are treated as open circuits. The various equations are:

$$I_{BE2} = I_{SE} \left[\exp\left(\frac{V_{BE}}{n_e V_T}\right) - 1 \right]$$

$$I_{BC2} = I_S \left[\exp\left(\frac{V_{BC}}{n_c V_T}\right) - 1 \right]$$

$$K_{q1} = \frac{1}{1 - \frac{V_{BC}}{V_A}}$$

$$K_{q2} = \frac{I_S}{IKF} \left[\exp\left(\frac{V_{BE}}{V_T}\right) - 1 \right]$$

$$K_{qb} = \frac{K_{q1}}{2} \left(1 + \sqrt{1 + 4K_{q2}} \right)$$

$$I_{CE} = \frac{I_S}{K_{qb}} \left[\exp\left(\frac{V_{BE}}{V_T}\right) - 1 \right]$$

$$I_{CC} = \frac{I_S}{K_{qb}} \left[\exp\left(\frac{V_{BC}}{V_T}\right) - 1 \right]$$

$$I_{CT} = I_{CE} - I_{CC}$$

$$I_{BE1} = I_S \left[\exp\left(\frac{V_{BE}}{V_T}\right) - 1 \right]$$

$$I_{BC1} = I_S \left[\exp\left(\frac{V_{BC}}{V_T}\right) - 1 \right]$$

where

V_T = thermal voltage = 0.0258

V_A = forward early voltage

The model parameter β_f is equivalent to β_{DC} in the DC case and β_{AC} in the AC case.

Other symbols used in these equations are defined in “BJT Model Parameters and Defaults.”

F.1.2 Time-Domain Model

The BJT time-domain model takes into account the parasitic emitter, base and collector resistances, and also the junction, diffusion, and substrate capacitances. The capacitors in the model are represented by their energy storage model derived using the appropriate numerical integration rule.

$$C_{BE} = \begin{cases} \tau_F \frac{dI_{CC}}{dV_{BE}} + C_{jE0} \left(1 - \frac{V_{BE}}{\phi_E}\right)^{-m_E} & \text{for } V_{BE} < FC * \phi_E \\ \tau_F \frac{dI_{CC}}{dV_{BE}} + \frac{C_{jE0}}{F_2} \left(F_3 + \frac{m_E V_{BE}}{\phi_E}\right) & \text{for } V_{BE} \geq FC * \phi_E \end{cases}$$

$$C_{BC} = \begin{cases} \tau_R \frac{dI_{EC}}{dV_{BC}} + C_{jC0} \left(1 - \frac{V_{BC}}{\phi_C}\right)^{-m_C} & \text{for } V_{BC} < FC * \phi_C \\ \tau_R \frac{dI_{EC}}{dV_{BC}} + C_{jC0} \left(F_3 + \frac{m_C V_{BC}}{\phi_C}\right) & \text{for } V_{BC} \geq FC * \phi_C \end{cases}$$

$$C_{sub} = \begin{cases} C_{js0} \left(1 - \frac{V_{CS}}{\phi_s}\right)^{-m_s} & \text{for } V_{CS} < 0 \\ C_{js0} \left(1 + \frac{m_s V_{CS}}{\phi_s}\right) & \text{for } V_{CS} > 0 \end{cases}$$

$$C_{JX} = \begin{cases} C_{jC0} (1 - X_{CJC}) \left(1 - \frac{V_{BX}}{\phi_C}\right)^{-m_C} & \text{for } V_{BX} < FC * \phi_C \\ \frac{C_{jC0} (1 - X_{CJC})}{F_2} * \left(F_3 + \frac{m_C V_{BX}}{\phi_C}\right) & \text{for } V_{BX} \geq FC * \phi_C \end{cases}$$

where, for the base-emitter junction, C_{BE} ,

$$F_2 = (1 - FC)^{1+m_E}$$

$$F_3 = 1 - FC(1 + m_E)$$

and for the base-collector junction, C_{BC} and C_{JX} ,

$$F_2 = (1 - FC)^{1+m_C}$$

$$F_3 = 1 - FC(1 + m_C)$$

The symbols used in these equations are defined in “BJT Model Parameters and Defaults.”

F.1.3 AC Small-Signal Model

The small-signal model of a BJT is automatically computed during linearization of the DC and large-signal time-domain models. The circuit shown is the Gummel-Poon small-signal model of an NPN transistor.

$$C_\pi = C_{BE}|_{OP} \quad g_\pi = \frac{I_B}{V_T}|_{OP}$$

$$C_\mu = C_{BC}|_{OP} \quad g_m = \frac{I_C}{V_T}|_{OP}$$

$$C_s = C_{sub}|_{OP} \quad g_o = \frac{I_c}{V_A}|_{OP}$$

$$C_{JX} = C_{JX}|_{OP} \quad \beta_{ac} \frac{g_m}{g_\pi}$$

$$i_c = g_\pi v_{be} + g_\mu v_{ce}$$

where

- g_p = input conductance
- g_μ = reverse feedback conductance
- g_m = transductance
- g_o = output conductance.

F.1.4 BJT Model Parameters and Defaults

| Symbol | Parameter Name | Default | Example | Unit |
|------------------|-------------------------------------------|---------|---------|------|
| IS | Saturation current | 1e-16 | 1e-15 | A |
| βF | Forward current gain coefficient | 100 | 100 | - |
| βR | Reverse current gain coefficient | 1 | 1 | - |
| rb | Base ohmic resistance | 0 | 100 | W |
| re | Emitter ohmic resistance | 0 | 10 | W |
| rc | Collector ohmic resistance | 0 | 1 | W |
| Cs | Substrate capacitance | 0 | 1 | F |
| Ce, Cc | Zero-bias junction capacitances | 0 | 2e-09 | F |
| $\phi e, \phi c$ | Junction potentials | 0.75 | 0.75 | V |
| τF | Forward transit time | 0 | 1e-13 | s |
| τR | Reverse transit time | 0 | 10e-09 | s |
| me, mc | Junction grading coefficients | 0.33 | 0.5 | - |
| VA | Early voltage | 1e+30 | 200 | V |
| Ise | Base emitter leakage saturation current | 0 | 1e-13 | A |
| Ikf | Forward beta high-current knee-point | 1e+30 | 0.01 | A |
| Ne | Base-emitter leakage emission coefficient | 1.5 | 2 | - |
| NF | Forward current emission coefficient | 1 | 1 | - |
| NR | Reverse current emission coefficient | 1 | 1 | - |
| VAR | Reverse early voltage | 1e+30 | 200 | V |
| IKR | Reverse beta roll-off corner current | 1e+30 | 0.01 | A |
| ISC | B-C leakage saturation current | 0 | 0.01 | A |
| NC | B-C leakage emission coefficient | 2 | 1.5 | - |

| Symbol | Parameter Name | Default | Example | Unit |
|--------|-----------------------------------------------------------------------|---------|---------|------|
| IRB | Current for base resistance equal to $(r_b + RBM)/2$ | 1e+30 | 0.1 | A |
| RBM | Minimum base resistance at high currents | 0 | 10 | W |
| XTF | Coefficient for bias dependence of t_F | 0 | 0 | - |
| VTF | Voltage describing VBC dependence of t_F | 1e+30 | - | V |
| ITF | High current dependence of t_F | 0 | - | A |
| PTF | Excess phase at frequency equal to $1/(t_F * 2\pi)$ Hz | 0 | - | Deg |
| XCJC | Fraction of B-C depletion capacitance connected to internal base node | 1 | - | - |
| VJS | Substrate junction build-in potential | .75 | - | V |
| MJS | Substrate junction exponential factor | 0 | 0.5 | - |
| XTB | Forward and reverse beta temperature exponent | 0 | - | - |
| EG | Energy gap for temperature effect on I_S | 1.11 | - | eV |
| XTI | Temperature exponent for effect on I_S | 3 | - | - |
| KF | Flicker noise coefficient | 0 | - | - |
| AF | Flicker noise exponent | 1 | - | - |
| FC | Coefficient for forward-bias depletion capacitance formula | .5 | - | - |
| TNOM | Parameter measurement temperature | 27 | 50 | °C |

F.2 Resistor Biased BJT (NPN & PNP)

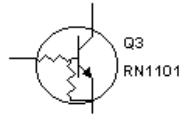

Resistor biased BJTs are discrete transistors which have had additional resistors added to them within a standard transistor package. This is done to reduce the space required on the PCB for the design. The general application is for transistor switches for displays such as LED and Hex displays.

They come in two varieties: with a NPN transistor or a PNP transistor.

F.3 Darlington Transistor (NPN & PNP)

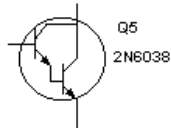

The Darlington connection is a connection of two bipolar junction transistors for operation as a composite transistor. The composite transistor acts as a single unit with a current gain that is the product of the current gains of each bipolar junction transistor.

F.3.1 DC Bias Model

If a Darlington transistor with a very high current gain, β_D , is used, the base current may be calculated from

$$I_B = \frac{V_{CC} - V_{BE}}{R_B + \beta_D R_E}$$

This equation is the same for a regular transistor, however, the value of β_D is much greater, and the value of V_{BE} is larger.

The emitter current is then

$$I_E = (\beta_D + 1)I_B \approx \beta_D I_B$$

DC voltages are:

$$V_E = I_E R_E$$

$$V_B = V_E + V_{BE}$$

F.3.2 AC Model

The AC input signal is applied to the base of the Darlington transistor through capacitor C_1 , with the ac output, V_o , obtained from the emitter through capacitor C_2 . The Darlington transistor is replaced by an ac equivalent circuit made up of an input resistance, r_i , and an output current source, $\beta_D I_b$.

F.3.2.1 AC Input Impedance

The AC input impedance looking into the transistor base is then

$$\frac{V_i}{I_b} = r_i + \beta_D R_E$$

The AC input impedance looking into the circuit is

$$Z_i = R_B \parallel (r_i + \beta_D R_E)$$

F.3.2.2 AC Current Gain

The AC circuit gain is as follows:

$$A_i = \beta_D \frac{R_B}{R_B + \beta_D R_E} = \frac{\beta_D R_B}{R_B + \beta_D R_E}$$

F.4 BJT Array

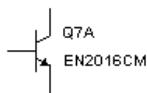

BJT arrays are collections of discrete transistors on a single die. They can come in many variations based on their intended application. The reasons for using an array is that the devices are more closely matched than a random group of discrete devices (eliminating the need to sort them), the noise characteristics are better, and the space required on a PCB is smaller.

There are three types of BJT arrays:

- PNP transistor array
- NPN/PNP transistor array
- NPN transistor array.

F.4.1 General-purpose PNP Transistor Array

This general-purpose silicon PNP transistor array incorporates two transistors, a Darlington circuit, and a current-mirror pair with a shared diode.

The two transistors can be used in circuit applications. The total array can be used in applications in systems with low-power and low-frequency requirements.

F.4.2 NPN/PNP Transistor Array

This general-purpose high-voltage silicon transistor array consists of five independent transistors (two PNP and three NPN types) on a common substrate, which has a separate connection. Separate connection for each transistor permits greater flexibility in circuit design.

This array is useful in applications including differential amplifiers, DC amplifiers, level shifters, timers, thyristor firing circuits and operational amplifiers.

F.4.3 General-purpose High-current NPN Transistor Array

This array consists of five high-current NPN transistors on a common monolithic substrate. Two of these transistors are matched at low currents for applications in which offset parameters are particularly important. Independent connections for each transistor and a separate terminal for the substrate allow for maximum flexibility in circuit design.

This array is useful in applications such as signal processing and switching systems operating from DC to VHF. Other applications include lamp and relay driver, differential amplifier, thyristor firing and temperature-compensated amplifier.

F.5 MOSFET

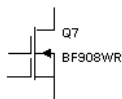

A MOSFET is a Metal-Oxide-Semiconductor FET. This transistor is a type of FET that uses an induced electrical field to control current through the device. Either negative or positive gate voltages can be applied to control the current.

The substrate is usually connected to the most negatively biased part of the MOSFET, usually the source lead. In the three-terminal MOSFETs, the substrate is internally connected to the source. N-channel MOSFETs have an inward-pointing substrate arrow, and

p-channel MOSFETs have an outward-pointing arrow. N-channel and p-channel MOSFETs are identical, except that their voltage polarities are opposite.

The 4-Terminal Enhanced N-MOSFET is an n-channel enhancement MOSFET. Because the substrate lead is not connected to the source lead, it has four terminals.

The 4-Terminal Enhanced P-MOSFET is a p-channel enhancement MOSFET. Because the substrate and source leads are not connected, it has four terminals.

Eight MOSFETs, both depletion-type and enhancement-type, are included in the parts bin.

F.5.1 Depletion MOSFETs

Like a JFET, a depletion MOSFET consists of a length of p-type (for a p-channel MOSFET) or n-type (for an n-channel MOSFET) semiconductor material, called the channel, formed on a substrate of the opposite type. The gate is insulated from the channel by a thin silicon dioxide (SiO_2) layer. Depletion MOSFETs are used in automatic-gain control (AGC) circuits.

3-terminal n-channel depletion MOSFET

3-terminal p-channel depletion MOSFET

4-terminal n-channel depletion MOSFET, substrate unconnected

4-terminal p-channel depletion MOSFET, substrate unconnected

F.5.2 Enhancement MOSFETs

An enhancement MOSFET has no physical channel between the drain and the source, unlike the depletion MOSFET. Instead, the substrate extends all the way to the silicon dioxide (SiO_2) layer. An enhancement MOSFET works only with positive gate-source voltages. Enhancement MOSFETs are extensively used in digital circuits and large-scale integration (LSI) applications.

3-terminal n-channel enhancement MOSFET

3-terminal p-channel enhancement MOSFET

4-terminal n-channel enhancement MOSFET, substrate unconnected

4-terminal p-channel enhancement MOSFET, substrate unconnected

Multisim provides four MOSFET device models, which differ in the formulation of the current-voltage characteristic. The parameter **LEVEL** in the model dialog specifies the model to be used. **LEVEL 1** is a modified Shichman-Hodges model. **LEVEL 2** defines the geometry-based analytical model. **LEVEL 3** defines the semi-empirical short-channel model. **LEVEL 4** defines the BS1M1 model. **LEVEL 5** defines a new BS1M2 model.

F.5.3 DC Model

Due to the complexity of the MOSFET models used, only very basic formulas are provided in the following description.

The DC characteristics are modeled by a nonlinear current source, I_D .

Forward characteristics ($V_{DS} \geq 0$):

$$V_{TE} = V_{TO} + \gamma \left(\sqrt{\phi} - V_{BS} \right) - \sqrt{\phi} \quad \text{for } \gamma > 0, \phi > 0$$

$$I_D = \begin{cases} 0 & \text{for } (V_{GS} - V_{TE}) \leq 0 \\ \beta(V_{GS} - V_{TE})^2(1 + \lambda V_{DS}) & \text{for } 0 < (V_{GS} - V_{TE}) \leq V_{DS} \\ \beta(V_{DS} [2(V_{GS} - V_{TE}) - V_{DS}]) (1 + \lambda V_{DS}) & \text{for } 0 < V_{DS} \leq (V_{GS} - V_{TE}) \end{cases}$$

Reverse characteristics ($V_{DS} < 0$):

$$V_{TE} = V_{TO} = \gamma \left(\sqrt{\phi} - V_{BD} \right) - \sqrt{\phi}$$

$$I_D = \begin{cases} 0 & \text{for } (V_{GD} - V_{TE}) \leq 0 \\ -\beta(V_{GS} - V_{TE})^2(1 - \lambda V_{DS}) & \text{for } 0 < (V_{GD} - V_{TE}) \leq -V_{DS} \\ \beta(V_{DS} [2(V_{GD} - V_{TE}) + V_{DS}]) (1 - \lambda V_{DS}) & \text{for } 0 < V_{DS} \leq (V_{GD} - V_{TE}) \end{cases}$$

where

| | | |
|-----------|---|-----------------------------------------------------------------|
| λ | = | channel length modulation, measured in $\frac{1}{\text{volts}}$ |
| V_{TE} | = | threshold voltage, in volts |
| V_{TO} | = | zero-bias threshold voltage, in volts |
| γ | = | bulk-threshold parameter, in volts |
| ϕ | = | surface potential at strong inversion, in volts |
| V_{BS} | = | bulk-to-source voltage, in volts |

V_{BD} = bulk-drain voltage, in volts

V_{DS} = drain-to-source voltage, in volts

F.5.4 Time-Domain Model

The time-domain model takes into account the charge-storage effects of the junction diodes used to model MOSFETs. The diodes are modeled using the diode time-domain model described in the Diodes Parts Bin chapter.

F.5.5 AC Small-Signal Model

In the linearized small-signal model, the junction diodes used to model the MOSFETs are replaced by their equivalent small-signal models.

C_{GB} , C_{GS} , C_{GD} are zero-bias junction capacitances.

$$g_m = \left. \frac{dI_D}{dV_{GS}} \right|_{OP} \qquad g_{BS} = \left. \frac{dI_{BS}}{dV_{BS}} \right|_{OP}$$

$$g_{DS} = \left. \frac{dI_D}{dV_{GS}} \right|_{OP} \qquad g_{BD} = \left. \frac{dI_{BD}}{dV_{BD}} \right|_{OP}$$

$$g_{mBS} = \left. \frac{dI_D}{dV_{BS}} \right|_{OP}$$

F.5.6 MOSFET Level 1 Model Parameters and Defaults

| Symbol | Parameter Name | Default | Unit |
|--------|--------------------------------------------------------------------------------|---------|------------------|
| VTO | Threshold voltage | 0 | V |
| KP | Transconductance coefficient | 2e-05 | A/V ² |
| LAMBDA | Channel-length modulation | 0 | 1/V |
| PHI | Surface potential | 0.6 | V |
| GAMMA | Bulk-threshold parameter | 0 | V**0.5 |
| RD | Drain ohmic resistance | 0 | W |
| RS | Source ohmic resistance | 0 | W |
| IS | Bulk-junction saturation current | 1e-14 | A |
| CGBO | Gate-bulk overlap capacitance per meter channel length | 0 | F |
| CGDO | Gate-drain overlap capacitance per meter channel length | 0 | F |
| CGSO | Gate-source overlap capacitance per meter channel width | 0 | F |
| CBD | Zero-bias bulk-drain junction capacitance | 0 | F |
| CBS | Zero-bias bulk-source junction capacitance | 0 | F |
| PB | Bulk-junction potential | 0.8 | V |
| RSH | Drain and source diffusion sheet resistance | 0 | W |
| CJ | Zero-bias bulk junction bottom capacitance per m ² of junction area | 0 | F/m ² |
| MJ | Bulk junction bottom grading coefficient | 0.5 | – |
| CJSW | Zero-bias bulk junction sidewall capacitance per m of junction perimeter. | 0 | F/m |
| MJSW | Bulk junction sidewall grading coefficient | 0.5 | – |
| JS | Bulk junction saturation current per m ² of junction area | 0 | A/m ² |

| Symbol | Parameter Name | Default | Unit |
|--------|------------------------------------------------------------|---------|---------------------|
| TOX | Oxide thickness | 1e-07 | m |
| NSUB | Substrate doping | 0 | 1/cm ³ |
| NSS | Surface state density | 0 | 1/cm ² |
| TPG | Type of gate material | 1 | – |
| LD | Lateral diffusion | 0 | m |
| UO | Surface mobility | 600 | cm ² /Vs |
| KF | Flicker noise coefficient | 0 | – |
| AF | Flicker noise exponent | 1 | – |
| FC | Coefficient for forward-bias depletion capacitance formula | 0.5 | – |
| TNOM | Parameter measurement temperature | 27 | °C |

$r_D = r_S = 10\%$ to 15% of the on-state drain-source resistance, $R_{DS(on)}$.

F.6 JFETs (Junction FETs)

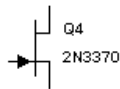

The JFET is a unipolar, voltage-controlled transistor that uses an induced electrical field to control current. The current through the transistor is controlled by the gate voltage. The more negative the voltage, the smaller the current.

A JFET consists of a length of an n-type or p-type doped semiconductor material called a channel. The ends of the channel are called the source and the drain. The terminal with the arrowhead represents the gate.

In an n-channel JFET, the gate consists of p-type material surrounding the n-channel. In a p-channel JFET, the gate consists of n-type material surrounding the p-channel.

F.6.1 DC Model

The DC model characteristic is determined by a nonlinear current source, I_D .

Forward characteristics ($V_{DS} \geq 0$):

$$I_D = \begin{cases} 0 & \text{for } (V_{GS} - V_{TO}) \leq 0 \\ -\beta(V_{GS} - V_{TO})^2(1 + \lambda V_{DS}) & \text{for } 0 < (V_{GS} - V_{TO}) \leq V_{DS} \\ \beta(V_{DS}[2(V_{GS} - V_{TO}) - V_{DS}](1 + \lambda V_{DS}) & \text{for } 0 < V_{DS} \leq (V_{GS} - V_{TO}) \end{cases}$$

Reverse characteristics ($V_{DS} < 0$):

$$I_D = \begin{cases} 0 & \text{for } (V_{GS} - V_{TO}) \leq 0 \\ -\beta(V_{GS} - V_{TO})^2(1 + \lambda V_{DS}) & \text{for } 0 < (V_{GS} - V_{TO}) \leq V_{DS} \\ \beta(V_{DS}[2(V_{GS} - V_{TO}) - V_{DS}](1 + \lambda V_{DS}) & \text{for } 0 < V_{DS} \leq (V_{GS} - V_{TO}) \end{cases}$$

where

| | | |
|---------------|---|-----------------------------------------------------------------------|
| V_{GS} | = | gate-source voltage, in volts |
| V_{DS} | = | drain-source voltage, in volts |
| V_{GD} | = | gate-drain voltage, in volts |
| $V_{GS(off)}$ | = | gate-source cutoff voltage, in volts |
| I_S | = | saturation current for the gate-drain and gate-source diode junctions |
| I_D | = | drain-to-source current, in amperes |
| I_{DSS} | = | drain-to-source saturation current, in amperes |

$$\beta = \frac{I_{DSS}}{[V_{GS(off)}]^2} = \text{transconductance parameter in } A/V^2$$

$$\lambda = \text{channel-length modulation parameter measured in } 1/V$$

Other symbols used in these equations are defined in “JFET Model Parameters and Defaults”.

Note β is not to be confused with g_m , the AC small-signal gain mentioned later in this chapter.

The charge storage occurring in the two gate junctions is modeled by the diode time-domain model described in the Diodes Parts Bin chapter.

The diodes used to model the JFETs are represented by their small-signal models.

$$g_m = \left. \frac{dI_D}{dV_{GS}} \right|_{OP}$$

$$g_{DS} = \left. \frac{dI_D}{dV_{DS}} \right|_{OP}$$

$$g_{GS} = \left. \frac{dI_{GS}}{dV_{GS}} \right|_{OP}$$

$$g_{GD} = \left. \frac{dI_{GD}}{dV_{GD}} \right|_{OP}$$

where

g_m = AC small-signal gain

g_{DS} = small-signal forward admittance or transconductance

g_{GS} and g_{GD} are normally very small because the diode junctions are not forward-biased.

I_{GS} and I_{GD} are the diode current expressions mentioned in the diode modeling section.

F.6.2 JFET Model Parameters and Defaults

| Symbol | Parameter Name | Default | Example | Unit |
|--------|------------------------------------------------------------|---------|---------|------------------|
| VTO | Threshold voltage | -2 | -2 | V |
| BETA | Transconductance coefficient | 0.0001 | 1e-03 | A/V |
| LAMBDA | Channel-length modulation | 0 | 1e-04 | 1/V ² |
| RD | Drain ohmic resistance | 0 | 100 | W |
| RS | Source ohmic resistance | 0 | 100 | W |
| IS | Gate-junction saturation current | 1e-14 | 1e-14 | A |
| Cgd | Zero-bias gate-drain junction capacitance | 0 | 1e-12 | F |
| Cgs | Zero-bias gate-source junction capacitance | 0 | 5e-12 | F |
| PB | Gate-junction potential | 1 | .06 | V |
| B | Doping tail parameter | 1 | 1.1 | - |
| KF | Flicker noise coefficient | 0 | - | - |
| AF | Flicker noise exponent | 1 | - | - |
| FC | Coefficient for forward-bias depletion capacitance formula | .5 | - | - |
| TNOM | Parameter measurement temperature | 27 | 50 | °C |

$r_D = r_S = 10\%$ to 15% of the on-state drain-to-source resistance, $R_{DS(on)}$.

F.7 Power MOSFET (N/P)

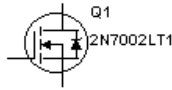

The double-diffused or DMOS transistor is an example of a power MOSFET. This device is fabricated on a lightly doped n -type substrate with a heavily doped region at the bottom for drain contact. Two diffusions are used, one to create the p -type body region and another to create the n -type

source region.

The DMOS device is operated by applying a positive gate voltage, v_{GS} , greater than the threshold voltage V_t , which induces a lateral n channel in the p -type body region underneath the gate oxide. Current is conducted through the resulting short channel to the substrate and then vertically down the substrate to the drain.

The DMOS transistor can have a breakdown voltage as high as 600 V and a current capability as high as 50 A is possible.

Power MOSFETs have threshold voltages in the range of 2 to 4 V. In comparison with BJTs, power MOSFETs do not suffer second breakdown, nor do they require the large base-drive currents of power BJTs. They also have a higher speed of operation than the power BJTs. These advantages make power MOSFETs suited to switching applications, such as in motor-control circuits.

F.8 N-Channel & P-Channel GaAsFET

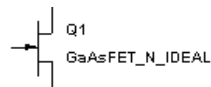

This component is a high-speed field-effect transistor that uses gallium arsenide (GaAs) as the semiconductor material rather than silicon. It is generally used as a very high frequency amplifier (into the gigahertz range). A GaAsFET consists of a length of n -type or p -type

doped GaAs called the channel. The ends of the channel are called the source and the drain. The terminal with the arrowhead represents the gate. GaAsFETs are used in microwave applications.

F.8.1 Model and Characteristic Equations

The GaAsFET component is based on the Statz model.

$$I_d = \begin{cases} 0 & \text{for } V_{gs} - V_{TO} < 0 \\ \beta * (1 + \lambda * V_{ds}) * (V_{gs} - V_{TO})^2 * \frac{\left(1 - \left(1 - V_{ds} * \frac{\alpha}{3}\right)^3\right)}{1 + \beta * (V_{gs} - V_{TO})} & \text{for } V_{gs} - V_{TO} \geq 0 \end{cases}$$

where

| | | |
|----------|---|-----------------------------------------------------------------|
| V_{gs} | = | gate-source voltage |
| V_{ds} | = | drain-source voltage |
| V_{TO} | = | threshold voltage; equivalent to the gate-source cutoff voltage |
| a | = | saturation voltage |
| b | = | transconductance |
| l | = | channel-length modulation |
| I_d | = | drain to source current |

F.8.2 GaAsFET Parameters and Defaults

| Symbol | Parameter name | Default | Unit |
|--------|------------------------------------------------------------|---------|------------------|
| VTO | Pinch-off voltage | -2 | V |
| BETA | Transconductance | 0.0001 | A/V ² |
| B | Doping tail extending parameter | 0.3 | 1/V |
| ALPHA | Saturation voltage | 2 | 1/V |
| LAMBDA | Channel-length modulation | 0 | 1/V |
| RD | Drain ohmic resistance | 0 | W |
| RS | Source ohmic resistance | 0 | W |
| CGS | Zero-bias G-S junction capacitance | 0 | F |
| CGD | Zero-bias G-D junction capacitance | 0 | F |
| PB | Gate junction potential | 1 | V |
| KF | Flicker noise coefficient | 0 | - |
| AF | Flicker noise exponent | 1 | - |
| FC | Coefficient for forward-bias depletion capacitance formula | 0.5 | |

F.9 IGBT

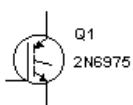

The IGBT is an MOS gate-controlled power switch with a very low on-resistance. It is similar in structure to the MOS-gated thyristor, but maintains gate control of the anode current over a wide range of operating conditions.

The low on-resistance feature of the IGBT is due to conductivity modulation of the n epitaxial layer grown on a p⁺ substrate. The on-resistance values have been reduced by a factor of about 10 compared with those of conventional n-channel power MOSFETs of similar size and voltage capability.

Changes to the epitaxial structure and the addition of recombination centers are responsible for the reduction in the fall time and an increase in the latching current level of the IGBT. Fall

Transistors Components

times as low as $0.1\mu\text{s}$ and latching currents as high as 50A can be achieved, while retaining on-resistance values $<0.2\Omega$ for a 0.09cm^2 chip area.

Appendix G

Analog Components

| | | |
|-----|----------------------------------------------|------|
| G.1 | Opamp | G-1 |
| | G.1.1 Opamp Model Parameters | G-1 |
| | G.1.2 Ideal Opamp Model | G-1 |
| | G.1.3 Opamp: Background Information | G-2 |
| | G.1.4 Opamp: Simulation Models | G-3 |
| | G.1.4.1L1 Simulation Model | G-3 |
| | G.1.4.2L2 Simulation Model | G-5 |
| | G.1.4.3L3 Simulation Model | G-8 |
| | G.1.4.4L4 Simulation Model | G-8 |
| G.2 | Norton Opamp | G-8 |
| | G.2.1 The Component | G-8 |
| | G.2.2 Norton Opamp: Simulation models. | G-8 |
| G.3 | Comparator | G-9 |
| | G.3.1 The Component | G-9 |
| | G.3.2 Comparator: Simulation models | G-10 |
| | G.3.3 Comparator Parameters and Defaults | G-10 |
| G.4 | Wide Band Amplifier | G-11 |
| | G.4.1 The Component | G-11 |
| | G.4.2 Wide Band Amplifier: Simulation models | G-11 |
| G.5 | Special Function | G-12 |
| | G.5.1 The Component | G-12 |
| | G.5.2 Special Function: Simulation models | G-12 |

Appendix G

Analog Components

G.1 Opamp

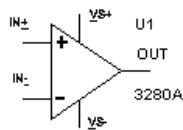

G.1.1 Opamp Model Parameters

An ideal operational amplifier (Opamp) is an amplifier with infinite gain, infinite input impedance and zero output impedance. With the application of negative feedback, Opamps can be used to implement functions such as addition, subtraction, differentiation, integration, averaging and amplification.

An opamp can have a single input and single output, a differential input and single output, or a differential input and differential output.

G.1.2 Ideal Opamp Model

The ideal opamp model is the fastest to simulate. Its characteristics include:

- open-loop voltage gain (A)

The open-loop gain is the gain of the opamp without any feedback applied which in the ideal opamp is infinite. This is not possible in the typical opamp, but it will be in the order of 120 dB.

- frequency response

The frequency response of an opamp is finite and its gain decreases with frequency. For stability, a dominant pole is intentionally added to the opamp to control this decreasing gain with frequency. In an internally compensated opamp, the response typically is set for -6dB/octave roll off with a -3dB frequency in range of 10 Hz. With an externally compensated Opamps, the -3 dB corner frequency can be changed by adding an external capacitor.

- unity-gain bandwidth

This is the frequency at which the gain of the opamp is equal to 1. This is the highest frequency at which the opamp can be used, typically as a unity gain buffer.

- common mode rejection ratio (CCMR)

This is the ability of an opamp to reject or to not amplify a signal that is applied to both its input pins expressed as a ratio (in dBs) of its common mode gain to its open loop gain.

- slew rate

This is the rate of change of output voltage expressed in volts per microsecond.

G.1.3 Opamp: Background Information

The operational amplifier is a high-gain block based upon the principle of a differential amplifier. It is common to applications dealing with very small input signals.

The open-loop voltage gain (A) is typically very large (10e+5 to 10e+6). If a differential input is applied across the “+” and “-” terminals, the output voltage will be:

$$V = A * (V+ - V-)$$

The differential input must be kept small, since the opamp saturates for larger signals. The output voltage will not exceed the value of the positive and negative power supplies (Vp), also called the rails, which vary typically from 5 V to 15 V. This property is used in a Schmitt trigger, which sets off an alarm when a signal exceeds a certain value.

Other properties of the opamp include a high input resistance (Ri) and a very small output resistance (Ro). Large input resistance is important so that the opamp does not place a load on the input signal source. Due to this characteristic, opamps are often used as front-end buffers to isolate circuitry from critical signal sources.

Opamps are also used in feedback circuits, comparators, integrators, differentiators, summers, oscillators and wave-shapers. With the correct combination of resistors, both inverting and non-inverting amplifiers of any desired voltage gain can be constructed.

G.1.4 Opamp: Simulation Models

Opamps are provided with several levels of simulation models of increasing complexity and accuracy. The following model levels are used to distinguish between the various models:

- L1 - this is the simplest model with the opamp modeled as a gain block with a differential input and a single ended output.
- L2 - this is a more complex model in which the supply voltages are included in the simulation.
- L3 - this is a model of increasing complexity where additional control pins are supported.
- L4 - this is the most complex and accurate model with a majority of the external control pins modeled.

G.1.4.1 L1 Simulation Model

This is the simplest simulation model and is equivalent to the Three Terminal Opamp model of EWB Version 5. This model is an idealized differential input, single output model that models only the first order characteristics of the opamp.

The modeled opamp parameters are:

- open loop gain
- input resistance
- output resistance
- slew rate
- unity-gain bandwidth
- input bias current
- input offset current

The opamp is modeled by distributing the open-loop voltage gain, A , across three stages. The first and second stages model the first and second poles of the opamp, and the third stage models the output impedance.

The same model is used for DC, time-domain and AC analyses.

$$I_{B1} = I_{BIAS} + \frac{I_{OS}}{2}$$

$$I_{B2} = I_{BIAS} - \frac{I_{OS}}{2}$$

$$I_1 = \frac{A_1 * V_{IN1}}{R_1}$$

$$A_1 = A^{1/3}$$

Analog Components

where

| | | |
|------------|---|-------------------------------------------|
| A_1 | = | open-loop voltage gain of the first stage |
| R_{IN} | = | input resistance, in ohm |
| I_{BIAS} | = | input bias current, in amperes |
| I_{OS} | = | input offset current, in amperes |

$$R_1 = 1 \text{ k}\Omega$$

$$f_{P1} = \frac{f_u}{A}$$

$$C_1 = \frac{1}{2\pi * R_1 * f_{P1}}$$

The slew rate limits the rate of change of I_1 to model the rate of change of output voltage.

$$I_1 = \frac{A_2 * V_{IN_2}}{R_2}$$

$$A_2 = A^{1/3}$$

$$R_2 = R_{OUT}$$

where

| | | |
|-----------|---|-------------------|
| R_{OUT} | = | output resistance |
|-----------|---|-------------------|

A third stage is introduced by specifying the location of the second pole:

$$C_2 = \frac{1}{2\pi * R_2 * f_{P2}}$$

$$R_2 = 1 \text{ k}\Omega$$

$$R_3 = R_{OUT}$$

$$I_3 = \frac{A^{1/3} * V_{IN}}{R_3}$$

where

| | | |
|----------|---|------------------------------------------------------------------------------------------------------------------------------------------|
| f_u | = | unity-gain bandwidth in hertz; i.e., the frequency at which the open-loop voltage gain equals 1. |
| f_{P2} | = | second-pole frequency. A third stage may be introduced by specifying the location of a second pole in hertz. |
| C_C | = | compensation capacitance, which shifts the dominant pole to the left in the frequency response. Its value is typically 30-40 picofarads. |
| SR | = | slew rate, which is the rate of change of output voltage (in V/s) in response to a step input. |

G.1.4.2 L2 Simulation Model

This is a more complex simulation model and is equivalent to the Five Terminal Opamp model of EWB Version 5. The base L2 model is a differential input, single output model based on the Boyle-Cohn-Pederson macro model, which includes the supply voltage connections. This model supports second order effects such as common-mode rejection, output voltage and current limiting characteristics of the opamp in addition to the first order effects.

The modeled opamp parameters are:

- open loop gain
- input resistance
- output resistance
- slew rate
- unity-gain bandwidth
- common mode rejection (CCMR)
- input bias current
- input offset current
- input bias current
- input offset voltage
- input bias voltage
- output voltage swing
- output current limiting

The internal components of a 741 opamp are shown below:

The circuit is divided into three stages. The input stage consists of ideal transistors, Q1 and Q2, and associated sources and passive elements. It produces the linear and nonlinear differential mode (DM) and common mode (CM) input characteristics. The capacitor, C_c , introduces a second order-effect for the slew rate and $C1$ introduces a second-order effect to the phase response.

$$I_{C1} = \frac{SR * C_c}{2}$$

$$C_e = \frac{2 * I_c}{SR} \quad R_{C1} = \frac{1}{2\pi * f_u * C_c}$$

$$I_{B1} = I_{bs} + \frac{I_{OS}}{2}$$

$$\beta_1 = \frac{I_{C1}}{I_{B1}}$$

$$\beta_2 = \frac{I_{C1}}{I_{B2}}$$

$$I_{EE} \left(\frac{(\beta_1 + 1)}{\beta_1} + \frac{(\beta_2 + 1)}{\beta_2} \right) I_{C1}$$

$$R_E = \frac{200}{I_{EE}}$$

Assume $I_{S1} = 1e-16$

$$I_{S2} = I_{S1} \left(1 + \frac{V_{OS}}{0.025} \right)$$

$$C_1 = \frac{C_c}{2} \tan \Delta\phi$$

The interstage provides the DM and CM gains and consists of voltage-controlled current sources g_{cm} , g_a and g_b and resistors, R_{02} and R_2 . The dominant time constant of the opamp is provided by the internal feed-back capacitor, c_c . In some opamps, the two nodes of c_c are made available to the outside world for external compensation. The output stage models DC and AC output resistance. The elements $d3$, vc , $d4$ and ve provide maximum desired voltage swings. Elements $d1$, $d2$, rcc and gc provide the current-limiting function.

Interstage:

$$g_m = \frac{I_c}{0.02585}$$

$$R_{e1} = \frac{\beta_1 + \beta_2}{\beta_1 + \beta_2 + 2} \left[R_{C1} - \frac{1}{g_m} \right]$$

$$g_a = \frac{1}{R_{C1}}$$

$$g_b = \frac{A R_C}{100 e^3 R_{02}}$$

$$G_{cm} = \frac{G_a}{C_{MRR}}$$

Output stage:

$$R_{01} = \frac{R_{out}}{2}$$

$$R_{02} = R_{out} - R_{01}$$

$$I_x = 2 * I_c g_b - I_{SC}$$

$$I_{SD} = I_x \exp\left(\frac{-R_{01} * I_{SC}}{0.025}\right)$$

$$R_{CC} = \frac{0.025}{100 i_x} \ln \frac{I_x}{I_{SD}}$$

$$G_C = \frac{1}{R_C}$$

$$V_C = V_{CC} - V_{SW}^+ + V_T * I_n \frac{I_{SC}}{I_{SD}}$$

$$V_E = V_{ee} - V_{SW}^- + V_T * I_n \frac{I_{SC}}{I_{SD}}$$

Note In addition to the base L2 simulation model, other models of this complexity or level are supplied by the various manufacturers for their particular opamps.

G.1.4.3 L3 Simulation Model

This is a more complex simulation model that is equivalent to the Seven Terminal Opamp models of EWB Version 5. This model is supplied by the various manufacturers for the more complex Opamps that have additional pins to support functions such as external compensation and output offset balance controls.

Each model is unique as it was developed by the individual companies to support their products. Therefore, a general description of each model is not possible.

G.1.4.4 L4 Simulation Model

This is generally the most complex opamp simulation model and is equivalent to the Nine Terminal Opamp model of EWB Version 5. Models are supplied by the various manufacturers for the more complex Opamps that have additional pins to support functions such as external compensation and output offset balance controls.

Each model is unique as it was developed by the individual companies to support their products. Therefore, a general description of each model is not possible.

G.2 Norton Opamp

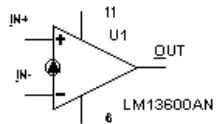

G.2.1 The Component

The Norton amplifier, or the current-differencing amplifier (CDA) is a current-based device. Its behavior is similar to an opamp, but it acts as a transresistance amplifier where the output voltage is proportional to the input current.

G.2.2 Norton Opamp: Simulation models

The same levels of simulation model as the opamps are provided with several levels of simulation models of increasing complexity and accuracy.

The following model levels are used to distinguish between these models:

- L1 - this is the simplest model with the opamp modeled as a gain block with a differential input and a single ended output.
- L2 - this is a more complex model in which the supply voltages are included in the simulation.
- L3 - this is a model of increasing complexity where additional control pins are supported.
- L4 - this is the most complex and accurate model with a majority of the external control pins modeled.

G.3 Comparator

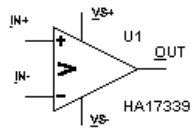

G.3.1 The Component

This component models the high-level behavior of a comparator. A comparator is an IC operational-amplifier whose halves are well balanced and without hysteresis and is therefore suitable for circuits in which two electrical quantities are compared. The comparator component models conversion speed, quantization error, offset error and output current limitation.

A comparator is a circuit that compares two input voltages and produces an output in either of two states, indicating the greater than or less than relationship of the inputs.

A comparator switches to one state when the input reaches the upper trigger point. It switches back to the other state when the input falls below the lower trigger point.

A voltage comparator may be implemented with any op-amp, with consideration for operating frequencies and slew rate, or with specialized ICs such as the LM339.

The comparator compares a reference voltage, fixed or variable, with an input waveform.

If the input is applied to the non-inverting input and the reference to the inverting input (lower circuit), the comparator will be operating in the non-inverting mode. In this case, when the input voltage is equal to (or slightly less than) the reference voltage the output will be at its lowest limit (near the negative supply) and when the input is equal to (or slightly greater than) the reference voltage the output will change to its highest value (near the positive supply).

If the inverting and non-inverting terminals are reversed (upper circuit) the comparator will operate in the inverting mode.

G.3.2 Comparator: Simulation models

The same levels of simulation model as the opamps are provided with several levels of simulation models of increasing complexity and accuracy.

The following model levels are used to distinguish between these models:

- L1 - this is the simplest model with the opamp modeled as a gain block with a differential input and a single ended output.
- L2 - this is a more complex model in which the supply voltages are included in the simulation.
- L3 - this is a model of increasing complexity where additional control pins are supported.
- L4 - this is the most complex and accurate model with a majority of the external control pins modeled.

G.3.3 Comparator Parameters and Defaults

| Symbol | Parameter name | Default | Unit |
|-------------------|---------------------------------|---------|------|
| Voffset | Input voltage offset | 0.7 | V |
| A | Gain | 200000 | V/V |
| Voh | Output high level | 3.5 | V |
| Vol | Output low level | 0.23 | V |
| Trr | Low-to-high response time | 1e-07 | s |
| Trf | High-to-low response time | 1.5e-07 | s |
| Tr | Rise time | 1e-07 | s |
| Tf | Fall time | 6e-08 | s |
| Icc+ | Positive supply current | 0.0051 | A |
| Icc- | Negative supply current | 0.0041 | A |
| I _{max+} | Maximum positive supply current | 0.006 | A |
| I _{max-} | Maximum negative supply current | 0.005 | A |

G.4 Wide Band Amplifier

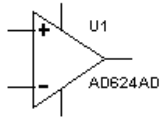

G.4.1 The Component

The typical opamp, such as a general purpose 741 type opamp, has been internally compensated for a unity gain bandwidth of about 1 MHz. Wide band amplifiers are opamps that have been designed with a unity gain bandwidth of greater than 10 MHz and typically in the 100 MHz range. These devices are used for application such as video amplifiers.

G.4.2 Wide Band Amplifier: Simulation models

The same levels of simulation model as the opamps are provided with several levels of simulation models of increasing complexity and accuracy.

The following model levels are used to distinguish between these models:

- L1 - this is the simplest model with the opamp modeled as a gain block with a differential input and a single ended output.
- L2 - this is a more complex model in which the supply voltages are included in the simulation.
- L3 - this is a model of increasing complexity where additional control pins are supported.
- L4 - this is the most complex and accurate model with a majority of the external control pins modeled.

G.5 Special Function

G.5.1 The Component

These are a group of analog devices that are used for the following applications:

- instrumentation amplifier
- video amplifier
- multiplier/divider
- preamplifier
- active filter

G.5.2 Special Function: Simulation models

The same levels of simulation model as the opamps are provided with several levels of simulation models of increasing complexity and accuracy.

The following model levels are used to distinguish between these models:

- L1 - this is the simplest model with the opamp modeled as a gain block with a differential input and a single ended output.
- L2 - this is a more complex model in which the supply voltages are included in the simulation.
- L3 - this is a model of increasing complexity where additional control pins are supported.
- L4 - this is the most complex and accurate model with a majority of the external control pins modeled.

Appendix H

Misc. Digital Components

| | | |
|--------|---------------------------|-----|
| H.1 | TIL Components | H-1 |
| H.1.1 | AND Gate | H-1 |
| H.1.2 | OR Gate | H-1 |
| H.1.3 | NOT Gate | H-2 |
| H.1.4 | NOR Gate | H-2 |
| H.1.5 | NAND Gate | H-3 |
| H.1.6 | XOR Gate (Exclusive OR) | H-4 |
| H.1.7 | XNOR Gate (Exclusive NOR) | H-4 |
| H.1.8 | Tristate Buffer | H-5 |
| H.1.9 | Buffer | H-5 |
| H.1.10 | Schmitt Trigger | H-6 |
| H.2 | VHDL | H-6 |
| H.3 | Line Receiver | H-9 |
| H.4 | Line Driver | H-9 |
| H.5 | Line Transceiver | H-9 |

Misc. Digital

Electronics Workbench

Appendix H Misc. Digital Components

H.1 TIL Components

H.1.1 AND Gate

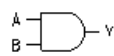

This component has a high output only when all inputs are high.

AND gate truth table:

| a | b | y |
|---|---|---|
| 0 | 0 | 0 |
| 0 | 1 | 0 |
| 1 | 0 | 0 |
| 1 | 1 | 1 |

Boolean Expression:

$$y = a * b$$

$$y = a \& b$$

H.1.2 OR Gate



This component has a high output when at least one input is high.

OR gate truth table:

| a | b | y |
|---|---|---|
| 0 | 0 | 0 |
| 0 | 1 | 1 |
| 1 | 0 | 1 |
| 1 | 1 | 1 |

Boolean Expression:

$$y = a + b$$

$$y = a|b$$

H.1.3 NOT Gate



This component inverts, or complements, the input signal. If the input is high, the output is low, and vice versa.

NOT gate truth table:

| a | y |
|---|---|
| 0 | 1 |
| 1 | 0 |

Boolean Expression:

$$y = a'$$

$$y = \bar{a}$$

H.1.4 NOR Gate



This component is a NOT OR, or an inverted OR gate. Its output is high only when all the inputs are low. Using a NOR gate is the same as having a NOT gate at the output of an OR gate.

Equivalent circuit:

NOR gate truth table:

| a | b | y |
|---|---|---|
| 0 | 0 | 1 |
| 0 | 1 | 0 |
| 1 | 0 | 0 |
| 1 | 1 | 0 |

Boolean Expression:

$$y = (a + b)'$$

$$y = \overline{a + b}$$

H.1.5 NAND Gate

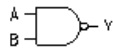

This component is a NOT AND, or inverted AND, gate. Its output is low only when all inputs are high. Using a NAND gate is the same as having a NOT gate at the output of an AND gate.

Equivalent circuit:

NAND gate truth table:

| a | b | y |
|---|---|---|
| 0 | 0 | 1 |
| 0 | 1 | 1 |
| 1 | 0 | 1 |
| 1 | 1 | 0 |

Boolean Expression:

$$y = (a * b)'$$

$$y = \overline{a * b}$$

H.1.6 XOR Gate (Exclusive OR)

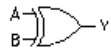

This component has a high output when an odd number of inputs (1, 3, 5, etc.) is high. An even number of high inputs generates a low output.

XOR gate truth table:

| a | b | y |
|---|---|---|
| 0 | 0 | 0 |
| 0 | 1 | 1 |
| 1 | 0 | 1 |
| 1 | 1 | 0 |

Boolean Expression:

$$y = a \oplus b$$

$$y = a'b + ab'$$

H.1.7 XNOR Gate (Exclusive NOR)



This component has a high output when an even number of inputs (2, 4, 6, etc.) is high. An odd number of high inputs generates a low output.

XNOR gate truth table:

| a | b | y |
|---|---|---|
| 0 | 0 | 1 |
| 0 | 1 | 0 |
| 1 | 0 | 0 |
| 1 | 1 | 1 |

Boolean Expression:

$$y = \overline{a \oplus b}$$

$$y = (a'b + ab)'$$

H.1.8 Tristate Buffer



This component is a non-inverting buffer with a three-state output. It has a greater fan-out and offers a high-current source and sink capability for driving high-current loads. The buffer has an active-high enable input.

If the device is not “enabled”, then the buffer output goes into a high-impedance (Z) state. In this state, the output pin is effectively disconnected from the rest of the circuit. Thus, the buffer is useful for circuits where outputs from different digital devices meet at the same node.

Truth table:

| input | enable input | output |
|-------|--------------|--------|
| 1 | 1 | 1 |
| 0 | 1 | 0 |
| X | 0 | Z |

where Z is a high-impedance state

Note When using a tristate buffer use the Models tab of the Circuit/Component Properties dialog box. Select the LS-BUF or LS-OC-BUF (OC = Open-collector) model if the buffer is being used as a TTL device. Select HC-BUF or HC-OD-BUF if the tristate buffer is being used as a CMOS device. Otherwise, by default, the tristate buffer will behave as a regular digital device without any high-current capabilities.

H.1.9 Buffer



This component is a non-inverting buffer. It has a greater fan-out and offers a high-current source and sink capability for driving high-current loads.

Truth table:

| input | output |
|-------|--------|
| 1 | 1 |
| 0 | 0 |

Note When using a buffer, set it up using the Models tab of the Circuit/Component Properties dialog box. Select the LS-BUF or LS-OC-BUF model if the buffer is being used as a TTL device. Select HC-BUF or HC-OD-BUF if the buffer is being used as a CMOS device. Otherwise, by default, the buffer will behave as a regular digital device without any high-current capabilities.

H.1.10 Schmitt Trigger



This component is a type of comparator with hysteresis that produces uniform-amplitude output pulses from a random-amplitude input signal. It has applications in pulse systems, for example, converting a sine wave into a square wave.

Characteristic Operation:

The Schmitt trigger outputs:

- 0 if the voltage is rising and $V_{in} > V_{+g}^+$
- 1 if the voltage is falling and $V_{in} < V_{+g}^-$

where

$$V_{+g}^+ = 1.6 V (V_{ih})$$

$$V_{+g}^- = 0.9 V (V_{il})$$

H.2 VHDL

The components in the VHDL family are digital components in VHDL. The models were obtained from the Free Model Foundation (<http://www.fmf.org>). The source for these components is installed by default in the vhd\fmfparts subdirectory of the Multisim directory. In that subdirectory, the VHDL description files named with the form 'STDxx', for example, model the equivalent component in the TTL '74xx' series (e.g.: STD00.vhd is the VHDL description for the 7400).

ECL10016.VHD: 4-Bit Synchronous Binary Up Counter

ECL10102.VHD: 2-input NOR and 2-input OR/NOR

ECL10104.VHD: 2-input AND and 2-input AND/NAND

ECL10124.VHD: TTL-to-ECL Translator

ECL10131.VHD: Dual D Flip-Flop with Set, Reset and Clock Enable
ECL10141.VHD: 4-Bit Universal Shift Register
IF75155.VHD: RS-232 Driver/Receiver
IF75172.VHD: Quad Differential Line Drivers
IF75173.VHD: Quad Differential Line Receivers
IF75179.VHD: Differential Driver/Receiver Pair
IF75188.VHD: RS-232 Quad Line Driver
IF75189.VHD: RS-232 Line Receiver
STD00.VHD: 2-input positive-NAND gate
STD01.VHD: 2-input positive-NAND gate with open-collector output
STD02.VHD: 2-input positive-NOR gate
STD03.VHD: 2-input positive-NAND gate with open-collector output
STD04.VHD: Inverter
STD05.VHD: Inverter
STD06.VHD: Inverter with open collector output
STD07.VHD: Buffer/Driver with Open Collector Outputs
STD08.VHD: 2-input positive-AND gate
STD10.VHD: 3-input NAND gate
STD109.VHD: Positive-Edge Triggered J-K Flip-Flop
STD11.VHD: 3-input positive-AND gate
STD125.VHD: Line driver with 3-state output
STD132.VHD: 2-input positive-NAND gate
STD138.VHD: 3 to 8 decoder
STD139.VHD: 2 to 4 decoder
STD14.VHD: Inverter
STD157.VHD: 2:1 Mux with enable
STD16260.VHD: Multiplexed D Latch with 3-State Outputs
STD16500.VHD: Universal Bus Transceiver
STD16501.VHD: Universal Bus Transceiver
STD16601.VHD: Universal Bus Transceiver
STD240.VHD: Inverting line driver with 3-state output
STD244.VHD: Line driver with 3-state output

STD245.VHD: 8-bit TTL Transceiver
STD257.VHD: 2:1 Mux with 3-state output
STD258.VHD: 2:1 Mux with 3-state inverting output
STD26.VHD: 2-input positive-NAND gate with open-collector output
STD273.VHD: D Flip-Flop with Clear
STD32.VHD: 2-input positive-OR gate
STD373.VHD: Transparent Latch
STD374.VHD: Positive-Edge Triggered Flip-Flop
STD377.VHD: Octal D-Type Flip-Flop with Enable (8-Bit Hold Register)
STD38.VHD: Quadruple 2-input positive-NAND buffers
STD521.VHD: 8-Bit Identity Comparator
STD533.VHD: D Latch with 3-State Outputs
STD541.VHD: Driver with 3-state output
STD543.VHD: Latched Transceiver
STD544.VHD: Inverting Latched Transceiver
STD574.VHD: Positive-Edge Triggered Flip-Flop
STD640.VHD: Bidirectional Bus Transceiver
STD652.VHD: Registered Bus Transceiver with 3-State Output
STD74.VHD: Positive-Edge Triggered Flip-Flop
STD821.VHD: Bus Interface Flip-Flop with 3-State Output
STD823.VHD: Bus Interface Flip-Flop with 3-State Output
STD825.VHD: Buffer with 3-state output
STD827.VHD: Buffer with 3-state output
STD832.VHD: 2-input positive-OR gate
STD86.VHD: 2-input exclusive-OR gate
STD869.VHD: Synchronous 8-Bit Up/Down Counter
STD952.VHD: Registered Transceiver with 3-State Output
STDH244.VHD: Line driver with 3-state output and bus hold
STDH245.VHD: TTL Transceiver with bus hold
STDH374.VHD: Positive-Edge Triggered Flip-Flop with bus hold
STDH543.VHD: Latched Transceiver with bus hold
STDH652.VHD: Reg Bus Transceiver with 3-State Output and Bus Hold

STDH952.VHD: Registered Transceiver with 3-State Output and bus hold
SY69167.VHD: 64 X 18 FIFO

H.3 Line Receiver

Line receivers are devices which are used in applications such as a bridge between analog signal and digital signals such as RS232 interfaces, or long signal runs over cables. The line receivers are placed at the receiving end of the application before the digital circuits.

H.4 Line Driver

Line drivers are devices which are used in applications such as a bridge between analog signal and digital signals such as RS232 interfaces, or long signal runs over cables. The line drivers are placed at the transmitting end of the application after the digital circuits.

H.5 Line Transceiver

Line transceivers are devices, which are used in applications such as a bridge between analog signal and digital signals such as RS232 interfaces, or long signal runs over cables. The line transceivers are placed between the digital circuits.

Misc. Digital

Appendix I

Mixed Components

| | | |
|-------|-------------------------------------------|-----|
| I.1 | ADC DAC | I-1 |
| I.1.1 | Characteristic Equation | I-1 |
| I.2 | Analog Switch | I-2 |
| I.3 | Timer | I-3 |
| I.3.1 | Model | I-3 |
| I.4 | Mono Stable | I-3 |
| I.4.1 | Model | I-4 |
| I.5 | Phase-Locked Loop | I-4 |
| I.5.1 | Characteristic Equation | I-5 |
| I.5.2 | Phase-Locked Loop Parameters and Defaults | I-6 |

Mixed

Electronics Workbench

Appendix I Mixed Components

I.1 ADC DAC

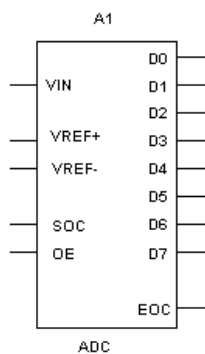

An ADC is a special type of encoder that converts the input analog voltage to an equivalent output digital word. There are five inputs and nine outputs.

I.1.1 Characteristic Equation

The V_{in} input is the analog voltage input. The voltage at V_{ref+} and V_{ref-} pins set up the full-scale voltage. The full-scale voltage is given by:

$$V_{fs} = V_{ref+} - V_{ref-}$$

To start the conversion, the SOC pin should be driven high. This pulls the EOC pin low, signifying that a conversion is taking place. The conversion takes $1 \mu\text{s}$ to complete and the EOC pin is pulled high when it is completed. The output digital data is now available at pins D0 through D7. These are tri-stated outputs pins which may be enabled by pulling the OE pin high.

The output at the end of the conversion process is the digital equivalent of the analog input voltage. The discrete value corresponding to the quantized level of input voltage is given by:

$$\frac{\text{input voltage} * 256}{V_{fs}}$$

Note that the output described by this formula is not a continuous function of input voltage. The discrete value is then encoded into the binary digital form at pins D0 through D7. The binary output is thus given by:

$$BIN \left[\frac{\text{input voltage} * 256}{V_{fs}} \right]$$

I.2 Analog Switch

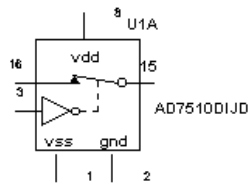

This switch is a resistor that varies logarithmically between specified values of a controlling input voltage. Note that the input is not internally limited. Therefore, if the controlling signal exceeds the specified C_{off} or C_{on} values, the resistance may become excessively large or small.

The voltage controlled switch has a function similar to that performed by a mechanical On/Off switch except that the On/Off conditions are selected by a control voltage.

When the control voltage is below a selected value, the switch is off and the input and output signals are disconnected.

When the control voltage is above the selected value, the switch is on and the input and output signals are connected.

I.3 Timer

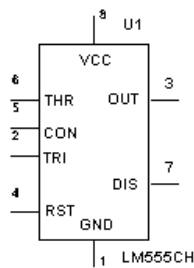

The 555 timer is an IC chip that is commonly used as an astable multivibrator, a monostable multivibrator or a voltage-controlled oscillator. The 555 timer consists basically of two comparators, a resistive voltage divider, a flip-flop and a discharge transistor. It is a two-state device whose output voltage level can be either high or low. The state of the output can be controlled by proper input signals and time-delay elements connected externally to the 555 timer.

I.3.1 Model

The internal diagram of a 555 timer is shown below:

The resistive voltage divider is used to set the voltage comparator levels. All three resistors are of equal value. The upper comparator has a reference voltage of $2/3 V_{CC}$ and the lower comparator has a reference of $1/3 V_{CC}$. The comparator's output controls the state of the flip-flop and hence the output. When the trigger voltage goes below $1/3 V_{CC}$, the output of the lower comparator goes high, and the flip-flop sets. The output thus jumps to a high level. The threshold input is normally connected to an external RC timing network. When the external voltage exceeds $2/3 V_{CC}$, the upper comparator's output goes high and resets the flip-flop, which in turn switches the output back to the low level. When the device output is low, the discharge transistor, Q, is turned on and provides a path for the discharge of the external timing capacitor.

This basic operation allows the timer to be configured with external components as an oscillator, a monoshot or a time-delay element.

I.4 Mono Stable

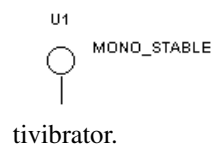

This component produces an output pulse of a fixed duration in response to an "edge" trigger at its input. The length of the output pulse is controlled by the timing RC circuit connected to the monostable multivibrator.

I.4.1 Model

A monostable multivibrator has two digital inputs: A1 and A2. The multivibrator can be triggered by a positive edge of digital signal at A1 or a negative edge at A2. Once triggered, it ignores further inputs.

An RC combination connected to RT/CT and CT pins controls the duration of the pulse produced by the monostable at Q. A complementary output is produced at W.

➤ To operate the monostable, the following connections may be used:

- Connect a series resistor (R) and capacitor (C) to the CT input.
- Connect the junction of the R and C to the RT/CT.
- Connect V_{CC} to a voltage source.

The output Q will give a pulse of duration $0.0693 * R * C$ when either a positive clock edge is given to A1 or a negative edge is given to A2.

The threshold voltage (at which triggering starts) can be changed by modifying the model.

I.5 Phase-Locked Loop

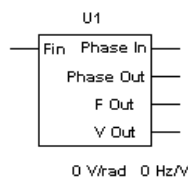

This component models the behavior of a phase-locked loop circuit, which is a circuit that contains an oscillator whose output phase and frequency are steered to keep it synchronized with an input reference signal.

A phase-locked loop circuit is composed of three functional blocks: a phase detector, a low-pass filter and a voltage-controlled oscillator (VCO). The phase detector behaves as an analog multiplier. It outputs a

DC voltage which is a function of the phase difference between the input reference signal and the VCO output signal. The output of the phase detector is input to the low-pass filter, which removes the high-frequency noise and outputs a DC voltage. The VCO converts the DC voltage into its corresponding frequency signal.

I.5.1 Characteristic Equation

The phase detector is modeled by:

$$V_d = K_d * \sin(\varphi_i - \varphi_o)$$

$$\varphi_i = 2\pi * \int f_i(t) dt$$

The low-pass filter is modeled by a simple passive RC low-pass filter, that is, a resistor and a capacitor, where R is 100 kW, and:

$$C = \frac{1}{2\pi * f_p * R}$$

The voltage-controlled oscillator (VCO) is modeled by:

$$f_o(t) = f_c + K_o * V_c(t)$$

$$\varphi_o = 2\pi * \int f_o(t) dt$$

where

- f_i = input frequency
- f_p = low-pass filter pole location
- f_o = VCO output frequency
- f_c = VCO free-running frequency
- V_d = phase detector output DC voltage
- V_o = VCO output voltage
- K_o = VCO conversion gain
- K_d = phase detector conversion gain
- φ_i = input signal phase
- φ_o = VCO output phase

I.5.2 Phase-Locked Loop Parameters and Defaults

| Symbol | Parameter name | Default | Unit |
|------------|--------------------------------|---------|------------|
| K_d | Phase detector conversion gain | 1.0 | V/rad |
| K_o | VCO conversion gain | 1.0 | Hz/V |
| f_c | VCO free-running frequency | 10 | kHz |
| f_p | Low-pass filter pole location | 100 | kHz |
| V_{om} | VCO output amplitude | 5.0 | V |
| R_{conv} | Convergence-aid resistance | 100 | M Ω |

Appendix J

Indicators Components

| | | |
|---------|--------------------------------------------------|-----|
| J.1 | Voltmeter | J-1 |
| J.1.1 | Resistance (1.0 W - 999.99 TW) | J-1 |
| J.1.2 | Mode (DC or AC) | J-1 |
| J.1.3 | Connecting a Voltmeter | J-2 |
| J.2 | Ammeter | J-2 |
| J.2.1 | Resistance (1.0 pW - 999.99 W) | J-2 |
| J.2.2 | Mode (DC or AC) | J-2 |
| J.2.3 | Connecting an Ammeter | J-2 |
| J.3 | Probe (LED) | J-3 |
| J.4 | Lamp | J-3 |
| J.4.1 | Time-Domain and AC Frequency Models | J-3 |
| J.5 | Hex Display | J-4 |
| J.5.1 | Seven-Segment Display | J-4 |
| J.5.2 | Decoded Seven-Segment Display | J-5 |
| J.6 | Bargraphs | J-6 |
| J.6.1 | The Component | J-6 |
| J.6.1.1 | Bargraph Display Parameters and Defaults | J-6 |
| J.6.2 | Decoded Bargraph Display | J-6 |
| J.6.2.1 | Decoded Bargraph Display Parameters and Defaults | J-7 |
| J.7 | Buzzer | J-7 |

Appendix J

Indicators Components

J.1 Voltmeter

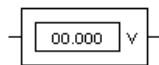

The voltmeter offers advantages over the multimeter for measuring voltage in a circuit. The advantage of using the voltmeter is that you can use an unlimited number of voltmeters in a circuit and you can rotate their terminals to suit your layout. The side with the heavier border is the negative terminal.

J.1.1 Resistance (1.0 Ω - 999.99 T Ω)

The voltmeter is preset to a very high resistance (1 M Ω (+)) which generally has no effect on a circuit. If you are testing a circuit that itself has very high resistance, you may want to increase the voltmeter's resistance to get a more accurate reading. (However, using a voltmeter with very high resistance in a low-resistance circuit may result in a mathematical round-off error.)

J.1.2 Mode (DC or AC)

The voltmeter can measure DC or AC voltage. In DC mode, any AC component of the signal is eliminated so that only the DC component of the signal is measured. In AC mode, any DC component is eliminated so that only the AC component is measured. When set to AC, the voltmeter displays the root-mean-square (RMS) value of the signal.

J.1.3 Connecting a Voltmeter

Connect the voltmeter in parallel with the load, attaching the probes to connectors on either side of the load you want to measure. When a circuit is activated and its behavior is simulated, the voltmeter displays the voltage across the test points. (The voltmeter may also display interim voltages before the final steady-state voltage is reached.)

Note If a voltmeter is moved after the circuit has been simulated, activate the circuit again to get a reading.

J.2 Ammeter

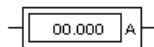

The ammeter offers advantages over the multimeter for measuring current in a circuit. The advantage of using the ammeter is that you can use an unlimited number of ammeters in a circuit and you can rotate their terminals to suit your layout. The side with the heavier border is the negative terminal.

J.2.1 Resistance (1.0 pΩ - 999.99 Ω)

The ammeter's resistance is preset to 1 mΩ, which presents little resistance to a circuit. If you are testing a circuit that has low resistance, you can lower the ammeter's resistance even further to get a more precise measurement. (However, using an ammeter with very low resistance in a high-resistance circuit may result in a mathematical round-off error.)

J.2.2 Mode (DC or AC)

The ammeter is preset to DC mode, which measures only the DC component of a signal. If you want to measure the current from an AC source, change the mode to AC. When set to AC, the ammeter displays the root-mean-square (RMS) value of the alternating signal.

J.2.3 Connecting an Ammeter

Like a real ammeter, the simulated ammeter must be connected in series at nodes you want to measure. The negative terminal is on the side with the heavy border. If an ammeter is moved after the circuit has been simulated, activate the circuit again to get a reading.

J.3 Probe (LED)

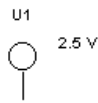

The probe indicates high (on) or low (off) levels at any point in a digital circuit. It lights up or turns off as the circuit is running. You can change the color of the probe from the Choose Probe tab of the Circuit/Component Properties dialog box.

J.4 Lamp

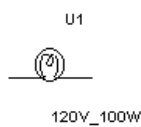

The lightbulb is an ideal, nonlinear resistive component that dissipates energy in the form of light. It has two rated values, maximum power (P_{max}) and maximum voltage (V_{max}). P_{max} is measured in watts, from mW to kW. V_{max} is measured in volts, from mV to kV. A bulb will burn out if the voltage across it exceeds V_{max} . At that point, the power dissipated in the bulb exceeds P_{max} .

J.4.1 Time-Domain and AC Frequency Models

The bulb is modeled by a resistor, R .

$$R = \frac{V_{max}^2}{P_{max}} \quad \text{if } |V_{ab}| \leq V_{max}$$

$$R = \infty \quad \text{if } |V_{ab}| > V_{max}$$

The bulb is lit if $\frac{V_{max}}{2} < |V_{ab}| \leq V_{max}$

where

V_{max} = the maximum voltage that can be applied across the bulb

P_{max} = the maximum power that can be dissipated by the bulb.

For AC circuits, V_{max} is the peak value of the applied voltage, not its RMS value.

J.5 Hex Display

J.5.1 Seven-Segment Display

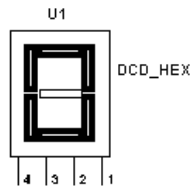

The seven-segment display actively shows its state while the circuit is running. The seven terminals (left to right, respectively) control segments a to g. By giving the proper binary-digit inputs to segments a to g, you can display decimal numbers from 0 to 9 and letters A to F.

Truth table:

| a | b | c | d | e | f | g | Digit displayed |
|---|---|---|---|---|---|---|-----------------|
| 0 | 0 | 0 | 0 | 0 | 0 | 0 | none |
| 1 | 1 | 1 | 1 | 1 | 1 | 0 | 0 |
| 0 | 1 | 1 | 0 | 0 | 0 | 0 | 1 |
| 1 | 1 | 0 | 1 | 1 | 0 | 1 | 2 |
| 1 | 1 | 1 | 1 | 0 | 0 | 1 | 3 |
| 0 | 1 | 1 | 0 | 0 | 1 | 1 | 4 |
| 1 | 0 | 1 | 1 | 0 | 1 | 1 | 5 |
| 1 | 0 | 1 | 1 | 1 | 1 | 1 | 6 |
| 1 | 1 | 1 | 0 | 0 | 0 | 0 | 7 |
| 1 | 1 | 1 | 1 | 1 | 1 | 1 | 8 |
| 1 | 1 | 1 | 1 | 0 | 1 | 1 | 9 |
| 1 | 1 | 1 | 0 | 1 | 1 | 1 | A |
| 0 | 0 | 1 | 1 | 1 | 1 | 1 | b |
| 1 | 0 | 0 | 1 | 1 | 1 | 0 | C |
| 0 | 1 | 1 | 1 | 1 | 0 | 1 | d |
| 1 | 0 | 0 | 1 | 1 | 1 | 1 | E |
| 1 | 0 | 0 | 0 | 1 | 1 | 1 | F |

J.5.2 Decoded Seven-Segment Display

This display indicates its current state by displaying hexadecimal digits—numerals 1 to 9 and letters A to F. It is easier to use than the regular seven-segment display because it is already decoded. Each hexadecimal digit is displayed when its 4-bit binary equivalent is received as input, as shown in the truth table below.

Truth table:

| a | b | c | d | Digit displayed |
|---|---|---|---|-----------------|
| 0 | 0 | 0 | 0 | 0 |
| 0 | 0 | 0 | 1 | 1 |
| 0 | 0 | 1 | 0 | 2 |
| 0 | 0 | 1 | 1 | 3 |
| 0 | 1 | 0 | 0 | 4 |
| 0 | 1 | 0 | 1 | 5 |
| 0 | 1 | 1 | 0 | 6 |
| 0 | 1 | 1 | 1 | 7 |
| 1 | 0 | 0 | 0 | 8 |
| 1 | 0 | 0 | 1 | 9 |
| 1 | 0 | 1 | 0 | A |
| 1 | 0 | 1 | 1 | b |
| 1 | 1 | 0 | 1 | C |
| 1 | 1 | 0 | 0 | d |
| 1 | 1 | 1 | 0 | E |
| 1 | 1 | 1 | 1 | F |

J.6 Bargraphs

J.6.1 The Component

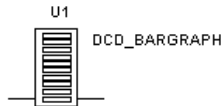

This display is an array of 10 LEDs arranged side by side. This component may be used to indicate visually the rise and fall of a voltage. The voltage to be measured needs to be decoded into levels using comparators which are used to drive each individual LED.

The terminals on the left side of the display are anodes and the terminals on the right are cathodes. Each LED lights up when the turn-on current, I_{on} , flows through it. You can change the voltage drop in the Value tab of the Circuit/Component Properties dialog box.

J.6.1.1 Bargraph Display Parameters and Defaults

| Symbol | Parameter Name | Default | Unit |
|----------|--------------------------------------------|---------|------|
| V_f | Forward voltage drop | 2 | V |
| I_f | Forward current at which V_f is measured | 0.03 | A |
| I_{on} | Forward current | 0.01 | A |

J.6.2 Decoded Bargraph Display

This display consists of 10 LEDs arranged side by side, just like the regular bargraph display. The difference is that the decoded bargraph display already has the decoding circuitry built-in so that it only requires the voltage to be measured as an input to the display. The circuitry inside decodes the voltage and lights up the appropriate number of LEDs, depending on the voltage level.

The decoded bargraph display also offers a very high resistance to the input voltage. The minimum voltages required for the lowest LED and the highest LED are set in the Value tab of the Circuit/Component Properties dialog box. The voltage at which each LED (from lowest to highest) lights up is given by the formula:

$$V_{on} = V_l + \frac{(V_h - V_l)}{9} * (n - 1)$$

where

$$n = 1, 2, \dots, 10 \text{ (the number of the LED)}$$

Other terms in this formula are defined in the table below.

J.6.2.1 Decoded Bargraph Display Parameters and Defaults

| Symbol | Parameter Name | Default | Unit |
|--------|----------------------------------------------------------|---------|------|
| V_l | Minimum turn-on voltage required for the lowest segment | 1 | V |
| V_h | Minimum turn-on voltage required for the highest segment | 10 | V |

J.7 Buzzer

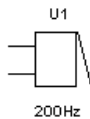

This component uses the computer's built-in speaker to simulate an ideal piezoelectric buzzer. A piezoelectric buzzer sounds at a specific frequency when the voltage across its terminals exceeds the set voltage.

The buzzer is simulated as a single resistor whose resistance value is dependent on the buzzer's rated voltage and the current. It beeps when the voltage across its terminals exceeds its voltage rating, V_{rated} .

$$\text{Buzzer resistance } r = \frac{V_{rated}}{i_{rated}}$$

$$\text{Beeps when } V_{ab} \geq V_{rated}$$

Indicators Components

Appendix K

Misc. Components

| | | |
|------|-----------------------------------------------------|------|
| K.1 | Crystal | K-1 |
| K.2 | DC Motor | K-2 |
| | K.2.1 Characteristic Equations | K-3 |
| | K.2.2 DC Motor Parameters and Defaults | K-4 |
| K.3 | Optocoupler | K-4 |
| K.4 | Vacuum Tube | K-4 |
| | K.4.1 Characteristic Equations | K-5 |
| | K.4.2 Model | K-5 |
| | K.4.3 Triode Vacuum Tube Parameters and Defaults | K-6 |
| K.5 | Voltage Reference | K-6 |
| K.6 | Voltage Regulator | K-7 |
| | K.6.1 Input/Output Voltage Differential Rating | K-7 |
| | K.6.2 DC Output Voltage | K-8 |
| K.7 | Voltage Suppressor | K-8 |
| K.8 | Boost Converter | K-8 |
| | K.8.1 Characteristic Equations | K-9 |
| | K.8.2 Boost Converter Parameters and Defaults | K-10 |
| K.9 | Buck Converter | K-10 |
| | K.9.1 Characteristic Equations | K-11 |
| | K.9.2 Buck Converter Parameters and Defaults | K-12 |
| K.10 | Buck Boost Converter | K-12 |
| | K.10.1 Characteristic Equations | K-13 |
| | K.10.2 Buck-Boost Converter Parameters and Defaults | K-14 |
| K.11 | Fuse | K-14 |
| | K.11.1 Characteristic Equations | K-14 |
| | K.11.2 Fuse Parameters and Defaults | K-15 |
| K.12 | Lossy Transmission Line | K-15 |

| | | |
|------|--------------------------------------------------------------------------|------|
| | K.12.1Model | K-15 |
| | K.12.2Lossy Transmission Line Model Parameters and Defaults | K-16 |
| K.13 | Lossless Line Type 1 | K-17 |
| | K.13.1Model | K-17 |
| | K.13.2Lossless Transmission Line Model Parameters and Defaults | K-18 |
| | K.13.3Lossless Line Type 2 | K-18 |
| K.14 | Net | K-18 |

Appendix K Misc. Components

K.1 Crystal

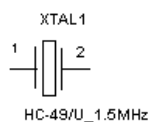

This component is made of pure quartz and behaves as a quartz crystal resonator, a circular piece of quartz with electrodes plated on both sides mounted inside an evacuated enclosure. When quartz crystals are mechanically vibrated, they produce an AC voltage. Conversely, when an AC voltage is applied across the quartz crystals, they vibrate at the frequency of the applied voltage. This is known as the piezoelectric effect and quartz is an example of a piezoelectric crystal.

The piezoelectric characteristics of quartz give the crystal the characteristics of a very high Q tuned circuit. The piezoelectric effect of quartz crystal links the mechanical and electrical properties of the resonator. Electrode voltage causes mechanical movement. Likewise, mechanical displacement generates an electrode voltage.

An equivalent circuit for a crystal shows a large inductor in series with a small resistance and a capacitance. When mounted in a holder with connections, a shunt capacitance is added to the equivalent circuit. The resultant equivalent circuit means that the crystal has both a series and parallel resonant frequency very close together.

Oscillators that employ crystals, typically quartz, offer excellent oscillation frequency stabilities of 0.001 percent. Crystal oscillators are used in digital wristwatches and in clocks that do not derive their frequency reference from the AC power line. They are also used in color television sets and personal computers. In these applications, one or more “quartz crystals” control frequency or time.

Another much more efficient transducer material than quartz is PZT. This ceramic material is ferroelectric and is made up of lead and other atoms, Ti or Zr. PZT consists of randomly oriented crystallites of varying size. The piezoelectric but not the ferroelectric property of the ceramic materials of the PZT family is made use of in transducer applications, such as ultrasonic echo ranging (sonar), medical diagnostic ultrasound and nondestructive testing system devices.

K.2 DC Motor

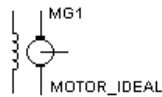

The component is a universal model of an ideal DC motor which can be used to model the behavior of a DC motor excited in parallel, in series or separately. The excitation type of the component is determined by the interconnection of the terminals between field windings (terminals 1 and

2) and armature windings (terminals 3 and 4).

To excite the DC motor in parallel, connect the positive terminal of a DC source to terminals 2 and 4; then connect the negative terminals of the DC source to terminals 1 and 3. To excite the DC motor in series, connect terminal 2 to terminal 3 (use a connector); then connect the positive terminal of a DC source to terminal 4 and connect the negative terminal of the DC source to terminal 1. To excite the DC motor separately, connect a DC source to terminals 2 and 1 (positive and negative, respectively); then connect another DC source to terminals 4 and 3 (positive and negative, respectively).

Terminal 5 is the DC motor's output. The output is the motor's rpm value.

- To display this value:
 - attach a voltmeter to terminal 5 (connect the other side of the voltmeter to ground) and simulate
 - or
 - attach the oscilloscope to terminal 5 and simulate (the rpm value is the voltage that appears)
 - or
 - attach a connector to terminal 5, then choose an appropriate analysis from the Analysis menu (for example, if you choose Analysis/DC Operating Point, the rpm value is the voltage at the connector).

This component connects the electrical and mechanical parts of a servo-system. Input to the motor is electrical while output is mechanical.

K.2.1 Characteristic Equations

The characteristic equations of an ideal DC motor are given by:

$$V_a = R_a * i_a + L_a \frac{di_a}{dt} + K_m * i_f * \omega_m$$

$$V_f = R_f * i_f + L_f \frac{di_f}{dt}$$

$$J \frac{d\omega_m}{dt} + B_f * \omega_m + T_L = K_m * i_f * i_a$$

where

ω_m = rotational speed

K_m = EMF constant

V_a = armature voltage

V_f = field voltage

Other terms are defined in “DC Motor Parameters and Defaults”.

The EMF constant K_m is determined by:

$$K_m = \frac{V_{aN} - I_{aN} * R_a}{I_{fN} * \frac{2\pi * n_N}{60}}$$

where

$$I_{fN} = \frac{V_{fN}}{R_f} \quad \text{for separately excited DC motor}$$

$$I_{fN} = \frac{V_{fN}}{R_f} = \frac{V_{aN}}{R_f} \quad \text{for parallel excited DC motor}$$

$$I_{fN} = \frac{V_{fN}}{R_f} = I_{aN} \quad \text{for series excited DC motor}$$

K.2.2 DC Motor Parameters and Defaults

| Symbol | Parameter Name | Default | Unit |
|----------|----------------------------|---------|-------------------------|
| R_a | Armature resistance | 1.1 | Ω |
| L_a | Armature inductance | 0.001 | H |
| R_f | Field resistance | 128 | Ω |
| L_f | Field inductance | 0.001 | H |
| B_f | Shaft friction | 0.01 | N.m.s/rad |
| J | Machine rotational inertia | 0.01 | N.m.s ² /rad |
| nn | Rated rotational speed | 1800 | RPM |
| V_{an} | Rated armature voltage | 115 | V |
| I_{an} | Rated armature current | 8.8 | A |
| V_{fn} | Rated field voltage | 115 | V |
| T_l | Load torque | 0.0 | N.m |

K.3 Optocoupler

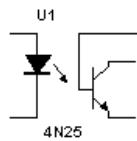

An optocoupler is a device that uses light to couple a signal from its input (a photoemitter) to its output (a photodetector).

A typical optocoupler can be found in a six-pin dual in-line package (DIP) containing both an LED and a photodetector, and a transistor Darlington pair or SCR. The wavelength response of each device is structured to be as identical as possible to permit the highest measure of coupling possible.

K.4 Vacuum Tube

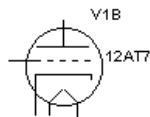

This component behaves as a three-electrode tube consisting of an anode, cathode and plate electrode. It is often used as an amplifier in audio applications.

The vacuum tube is a voltage controlled current device, very similar in operation to an N channel FET.

As for an FET, the gain of the tube is referred to as transconductance and is defined as the change in plate current resulting from a change in grid to cathode voltage

$$g_m = (\text{change in plate current}) / (\text{change in grid to cathode voltage})$$

K.4.1 Characteristic Equations

The DC characteristic of the triode vacuum tube is modeled by a two-dimensional voltage-controlled current:

$$I_p = \begin{cases} K(\mu^*V_{gk} + V_{pk})^{\frac{3}{2}} & \text{for } \mu^*V_{gk} + V_{pk} \geq 0 \\ 0 & \text{for } \mu^*V_{gk} + V_{pk} < 0 \end{cases}$$

where

$$K = \frac{I_p}{(\mu^*V_{gk} + V_{pk})^{\frac{3}{2}}}$$

Other items are defined in “Triode Vacuum Tube Parameters and Defaults”.

K.4.2 Model

The dynamic characteristic of the triode vacuum tube is modeled by its DC characteristic with three capacitances (Cgk, Cpk, and Cgp) which are associated interelectrodes.

K.4.3 Triode Vacuum Tube Parameters and Defaults

| Symbol | Parameter name | Default | Unit |
|--------|---------------------------|---------|------|
| Vpk | Plate-cathode voltage | 250 | V |
| Vgk | Grid-cathode voltage | -20 | V |
| Ip | Plate current | 0.01 | A |
| m | Amplification factor | 10 | - |
| Cgk | Grid-cathode capacitance | 2e-12 | F |
| Cpk | Plate-cathode capacitance | 2e-12 | F |
| Cgp | Grid-plate capacitance | 2e-12 | F |

K.5 Voltage Reference

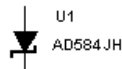

The output voltage of the Zener reference diode is set at approximately 6.9 V and requires a high voltage supply. The band-gap voltage reference diode has a significant advantage over the Zener reference diode in that it is capable of a lower minimum operating current and has a sharper knee.

The band-gap reference relies on matched transistors and is therefore easily integrated along with biasing, buffer and amplifier circuitry to give a complete reference diode.

The LM285/LM385 series are examples of micropower two-terminal band-gap voltage reference diodes. These devices are designed to operate over a wide current range of 10 μ A to 20 mA.

The features of these devices include exceptionally low dynamic impedance, low noise, and stable operation over time and temperature. The low operating current make these devices suitable for micropower circuitry, such as portable instrumentation, regulators and other analog circuitry that requires extended battery life.

Note Many types of two-terminal 1.2 V voltage reference diodes offer the same performance, but are not all directly interchangeable. Minor differences in regulation voltage and in allowable or required capacitive loading may affect a circuit.

K.6 Voltage Regulator

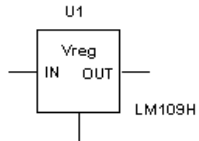

The linear IC voltage regulator is a device used to hold the output voltage from a dc power supply relatively constant over a wide range of line and load variations. Most commonly used IC voltage regulators are three-terminal devices.

There are four types of IC voltage regulators: fixed positive, fixed negative, adjustable, and dual tracking. The fixed-positive and fixed-negative IC voltage regulators are designed to provide specific output voltages. The adjustable regulator can be adjusted to provide any dc output voltage within two specified limits. The dual-tracking regulator provides equal positive and negative output voltages.

The regulator input-voltage polarity must match the device's rated output polarity regardless of the type of regulator used.

IC voltage regulators are series regulators, that is, they contain internal pass transistors and transistor control components. The internal circuitry of an IC voltage regulator is similar to that of the series feedback regulator.

K.6.1 Input/Output Voltage Differential Rating

The input/output voltage differential rating shows the maximum difference between V_{in} and V_{out} that can occur without damaging an IC voltage regulator.

The differential voltage rating can be used to determine the maximum allowable value of V_{in} as follows:

$$V_{in(max)} = V_{out(adj)} + V_d$$

where

- $V_{in(max)}$ = the maximum allowable unrectified dc input voltage
- $V_{out(adj)}$ = the adjusted output voltage of the regulator
- V_d = the input/output voltage differential rating of the regulator

K.6.2 DC Output Voltage

The following equation can be used to determine the dc output voltage of the circuit:

$$V_{dc} = 1.25 \left(\frac{R_2}{R_1} + 1 \right)$$

where

V_{dc} = the regulated dc output voltage of the regulator

K.7 Voltage Suppressor

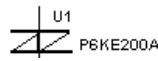

The voltage suppressor diode is a Zener diode that is capable of handling high surges. It is used as a filtering device to protect voltage-sensitive electronic devices from high energy voltage transients.

The voltage suppressor diode is connected across the AC power input line to a DC power supply. It contains two zener diodes that are connected back-to-back, making the voltage suppressor diode bi-directional. This characteristic enables it to operate in either direction to monitor under-voltage dips and over-voltage spikes of the AC input. It protects the power supply from surges by shorting out any voltages greater than the V_z (Zener voltage) ratings of the diodes.

The voltage suppressor diode must also have extremely high power dissipation ratings because most AC power line surges contain a relatively high amount of power, in the hundreds of watts or higher. It must also be able to turn on rapidly to prevent damage to the power supply.

In DC applications, a single unidirectional voltage suppressor can be used instead of a bi-directional voltage suppressor. It is connected in shunt with the DC input and reverse biased (cathode to positive DC).

K.8 Boost Converter

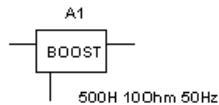

This component is an averaging circuit model that models the averaging behavior of a step-up DC-to-DC switching converter. It is based on a unified behavioral model topology. The topology models both small-signal and large-signal characteristics of this converter power stage. The model can be used to simulate DC, AC and large-signal transient

responses of switched-mode power supplies operating in both the continuous and discontinuous inductor current conduction modes (CCM and DCM, respectively).

K.8.1 Characteristic Equations

The averaging DC and large-signal characteristics of a Boost converter are given by the following sets of equations:

$$I_i = I_{LL} + I_{LD} = I_L$$

$$I_0 = \frac{D^2}{D+D^2} (I_{LL} + I_{LD}) = \frac{D^2}{D+D^2} * I_L$$

in which I_{LL} is governed by:

$$I_{LL} = \frac{1}{L} \int_0^t [D * V_i - D_2 (V_0 - V_i)] dt$$

where D = duty ratio of the switching device.

For the DCM:

$$D_2 = D * \frac{V_i}{V_0 - V_i}$$

$$V_i = 0$$

$$I_{LD} = \frac{D(D + D_2)}{2 * L * F_s} * V_i$$

For the critical condition between the CCM and the DCM of operations:

$$D_2 = 1 - D$$

$$I_{LD} = I_{Lcrit} = V_i * D * \frac{1}{2 * L * F_s}$$

For the CCM:

$$D_2 = 1 - D$$

$$V_L = D_i V_i - D_2 (V_0 - V_i)$$

$$I_L = I_{Lcrit} + I_{LL}$$

The averaging behavior governed by the above equations is modeled using the built-in Electronics Workbench analog behavioral modeling components. The AC small-signal model is automatically computed inside the program.

K.8.2 Boost Converter Parameters and Defaults

| Symbol | Parameter Name | Default | Unit |
|--------|---------------------|---------|------------------|
| L | Filter inductance | 500 | μH |
| R | Filter inductor ESR | 10 | $\text{m}\Omega$ |
| F_s | Switching frequency | 50 | kHz |

K.9 Buck Converter

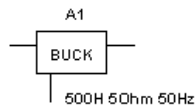

This component is an averaging circuit model that models the averaging behavior of a step-down DC-to-DC switching converter. It is based on a unified behavioral model topology. The topology models both small-signal and large-signal characteristics of this converter power stage.

The model can be used to simulate DC, AC and large-signal transient responses of switched-mode power supplies, operating in both the continuous and discontinuous inductor current conduction modes (CCM and DCM, respectively).

K.9.1 Characteristic Equations

The averaging DC and large-signal characteristics of a Buck converter are given by the following sets of equations:

$$I_i = \frac{D}{D + D_2} * (I_{LL} + I_{LD}) = \frac{D}{D + D_2} * I_L$$

$$I_o = -(I_{LL} + I_{LD}) = -I_L$$

in which I_{LL} is governed by:

$$I_{LL} = \frac{1}{L} \int_0^t [D(V_i - V_o) - D_2 V_o] dt$$

where D = duty ratio of the switching device.

For the DCM:

$$D_2 = D \frac{V_i - V_o}{V_o}$$

$$V_L = 0$$

$$I_{LD} = D(V_i - V_o) \frac{D + D_2}{2 * L * F_s}$$

For the critical condition between the CCM and DCM of operation:

$$D_2 = 1 - D$$

$$I_{LD} = I_{Lcrit} = \frac{V_i - V_o}{2 * L * F_s}$$

For the CCM:

$$D_2 = 1 - D$$

$$V_L = D(V_i - V_o) - D_2 * V_o$$

$$I_L = I_{Lcrit} + I_{LL}$$

The averaging behavior governed by the above equations is modeled using the built-in Electronics Workbench analog behavioral modeling components. The AC small-signal model is automatically computed inside the program.

K.9.2 Buck Converter Parameters and Defaults

| Symbol | Parameter Name | Default | Unit |
|--------|---------------------|---------|------------------|
| L | Filter inductance | 500 | μH |
| R | Filter inductor ESR | 5 | $\text{m}\Omega$ |
| F_s | Switching frequency | 50 | kHz |

K.10 Buck Boost Converter

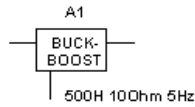

This component is an averaging circuit model that models the averaging behavior of a DC-to-DC switching converter. It is based on a unified behavioral model topology. The topology models both small-signal and large-signal characteristics of this converter power stage.

This behavioral model can be used to simulate DC, AC and large-signal transient responses of a variety of switched-mode power supplies, operating in both the continuous and discontinuous inductor current condition modes (DCM and CCM, respectively).

K.10.1 Characteristic Equations

$$I_i = \frac{D}{D + D_2} * (I_{LL} + I_{LD}) = \frac{D}{D + D_2} * I_L$$

$$I_o = \frac{D_2}{D + D_2} * (I_{LL} + I_{LD}) = \frac{D_2}{D + D_2} * I_L$$

in which I_{LL} is governed by:

$$I_{LL} = \frac{1}{L} \int_0^t [D * V_i - D_2 * V_o] dt$$

where D = duty ratio of the switching devices.

For the DCM:

$$D_2 = D \frac{V_i}{V_o}$$

$$V_L = 0$$

$$I_{LD} = \frac{D * V_i (D + D_2)}{2 * L * F_s}$$

For the critical condition between the CCM and the DCM of operation:

$$D_2 = 1 - D$$

$$I_{LD} = I_{Lcrit} = \frac{D * V_i}{2 * L * F_s}$$

For the CCM:

$$D_2 = 1 - D$$

$$V_L = D * V_i - D_2 * V_o$$

$$I_L = I_{Lcrit} + I_{LL}$$

The averaging behavior governed by these equations is modeled using Electronics Workbench's built-in analog behavioral modeling components. The AC small-signal model is automatically computed.

K.10.2 Buck-Boost Converter Parameters and Defaults

| Symbol | Parameter Name | Default | Unit |
|--------|---------------------|---------|---------------|
| L | Filter inductance | 500 | μH |
| R | Filter inductor ESR | 5 | mW |
| F_s | Switching frequency | 50 | kHz |

K.11 Fuse

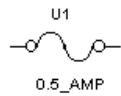

This is a resistive component that protects against power surges and current overloads.

A fuse will blow (open) if the current in the circuit goes above I_{max} , the maximum current rating. I_{max} can have any value from mA to kA.

The fuse is modeled by a resistor, R .

K.11.1 Characteristic Equations

$$R = 0 \quad \text{if } i_a \leq I_{max}$$

$$R = \infty \quad \text{if } i_a > I_{max}$$

where

$$i_a = \text{current through the fuse, in amperes}$$

$$I_{max} = \text{maximum current rating of the fuse, in amperes.}$$

For AC circuits, I_{max} is the peak value of the current, not its RMS value.

K.11.2 Fuse Parameters and Defaults

| Symbol | Parameter Name | Default | Unit |
|------------------------|-----------------|---------|------|
| <i>I_{max}</i> | Maximum current | 1 | A |

K.12 Lossy Transmission Line

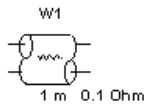

This component is a 2-port network that represents a medium, such as a wire or an interconnect, through which electrical signals pass.

The lossy model also models resistive losses in the line along with the characteristic impedance and propagation delay properties of the transmission line.

This is a two-part convolution model for single-conductor lossy transmission lines. The uniform constant-parameter distributed transmission line model can be used to model the following types of lines:

- RLC (uniform transmission lines with series loss only)
- RC (uniform RC lines)
- LC (lossless transmission lines)
- RG (distributed series and parallel conductance).

K.12.1 Model

The characteristic of a lossy transmission line is modeled by the Telegrapher Equations:

$$\frac{\partial v}{\partial x} = -(L \frac{\partial i}{\partial t} + Ri)$$

$$\frac{\partial i}{\partial x} = -(C \frac{\partial v}{\partial t} + Gv)$$

with the following boundary and initial conditions:

$$v(0,t) = v_1(t), \quad v(l,t) = v_2(t)$$

$$i(0,t) = i_1(t), \quad i(l,t) = -i_2(t)$$

$$v(x,0) = v_0(x), \quad i(x,0) = i_0(x)$$

where the transmission line stretches from x coordinates 0 to l

| | | |
|----------|---|-----------------------------------------------------|
| l | = | line length |
| $V(x,t)$ | = | voltage at point x at time t |
| $i(x,t)$ | = | current in the positive x direction at x at time t |
| $v(0,t)$ | = | voltage at point 0 at time t |
| $i(0,t)$ | = | current in the positive x direction at 0 at time t |
| $v(x,0)$ | = | voltage at point x at time 0 |
| $i(x,0)$ | = | current in the positive x direction at x at time 0. |

The set of equations is first transformed into a pair of coupled ordinary differential equations in x and s using the Laplace transformation. The equations are then reformulated for numerical convolution. Finally, inverse Laplace transforms are taken to return them to the time-domain form.

K.12.2 Lossy Transmission Line Model Parameters and Defaults

| Symbol | Parameter Name | Default | Unit |
|------------|---------------------------------|---------|----------|
| <i>Len</i> | Length of the transmission line | 100 | m |
| <i>Rt</i> | Resistance per unit length | 0.1 | Ω |
| <i>Lt</i> | Inductance per unit length | 1e-06 | H |
| <i>Ct</i> | Capacitance per unit length | 1e-12 | F |
| <i>Gt</i> | Conductance per unit length | 1e-12 | mho |
| <i>REL</i> | Breakpoint control | 1 | - |
| <i>ABS</i> | Breakpoint control | 1 | - |

Note A lossy transmission line with zero loss can be used to model the lossless transmission line, and may be more accurate.

K.13 Lossless Line Type 1

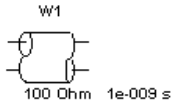

This component is a 2-port network that represents a medium, such as a wire or an interconnect, through which electrical signals pass.

The lossless model is an ideal one that simulates only the characteristic impedance and propagation delay properties of the transmission line. The characteristic impedance is resistive and is equal to the square-root of L/C .

Note A lossy transmission line with zero loss can be used to model the lossless transmission line, and may be more accurate.

K.13.1 Model

A lossless transmission line is an LC model as shown:

The values of L and C are given by:

$$ct = \frac{td}{Z}$$

$$lt = td * Z$$

where

ct = capacitance per unit length

lt = inductance per unit length

td = propagation time delay

Z = nominal impedance

The propagation time-delay may be calculated from the data-books as follows:

$$td = \left(\frac{length}{Vp} \right)$$

$$Vp = Vf * c$$

Misc. Components

where

| | | |
|----------|---|-------------------------|
| $length$ | = | length of the line |
| Vp | = | velocity of propagation |
| Vf | = | velocity-factor |
| c | = | speed of light |

K.13.2 Lossless Transmission Line Model Parameters and Defaults

| Symbol | Parameter Name | Default | Unit |
|--------|------------------------|---------|----------|
| $Z0$ | Nominal impedance | 100 | Ω |
| Td | Propagation time delay | 1e-09 | s |

K.13.3 Lossless Line Type 2

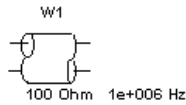

This component is similar to lossless line type 1.

K.14 Net

This is a template for building a model. It allows you to input a netlist, using from 2 to 20 pins.

Appendix L

Controls Components

| | | |
|-----|-------------------------------------------------------|------|
| L.1 | Multiplier | L-1 |
| | L.1.1 Characteristic Equation | L-3 |
| | L.1.2 Multiplier Parameters and Defaults | L-3 |
| L.2 | Divider | L-3 |
| | L.2.1 Characteristic Equation | L-5 |
| | L.2.2 Divider Parameters and Defaults | L-5 |
| L.3 | Transfer Function Block | L-6 |
| | L.3.1 Characteristic Equation | L-6 |
| | L.3.2 Transfer Function Block Parameters and Defaults | L-7 |
| L.4 | Voltage Gain Block | L-7 |
| | L.4.1 Characteristic Equation | L-8 |
| | L.4.2 Voltage Gain Block Parameters and Defaults | L-8 |
| L.5 | Voltage Differentiator | L-9 |
| | L.5.1 Investigations | L-9 |
| | L.5.1.1 Sine wave | L-9 |
| | L.5.1.2 Triangle waveforms | L-9 |
| | L.5.1.3 Square waves | L-9 |
| | L.5.2 Characteristic Equation | L-10 |
| | L.5.3 Voltage Differentiator Parameters and Defaults | L-11 |
| L.6 | Voltage Integrator | L-11 |
| | L.6.1 Investigations | L-11 |
| | L.6.2 Characteristic Equation | L-12 |
| | L.6.3 Voltage Integrator Parameters and Defaults | L-13 |
| L.7 | Voltage Hysteresis Block | L-13 |
| | L.7.1 Hysteresis Block Parameters and Defaults | L-14 |
| L.8 | Voltage Limiter | L-15 |
| | L.8.1 Characteristic Equation | L-16 |
| | L.8.2 Voltage Limiter Parameters and Defaults | L-16 |

| | | |
|--------|---------------------------------------------------------|------|
| L.9 | Current Limiter Block | L-16 |
| L.9.1 | Current Limiter Parameters and Defaults | L-18 |
| L.10 | Voltage-Controlled Limiter | L-19 |
| L.10.1 | Voltage-Controlled Limiter Parameters and Defaults..... | L-20 |
| L.11 | Voltage Slew Rate Block | L-20 |
| L.11.1 | Voltage Slew Rate Block Parameters and Defaults..... | L-21 |
| L.12 | Three-Way Voltage Summer | L-21 |
| L.12.1 | Characteristic Equation | L-23 |
| L.12.2 | Summer Parameters and Defaults..... | L-23 |

Appendix L Controls Components

L.1 Multiplier

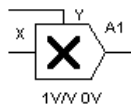

This component multiplies two input voltages.

The basic function multiplies the X and Y inputs.

$$V_o = V_x * V_y$$

Gain factors may be applied to the X and Y inputs and to the output.

Examples shown below:

- Two DC voltages are multiplied ($4V * 2V = 8V$)
- Two volts DC multiplied by 2v RMS ($2V * 2v \text{ RMS} = 4v \text{ RMS}$)
- Two AC signals, $2\sin x$ and $4 \cos x$

Controls Components

Controls

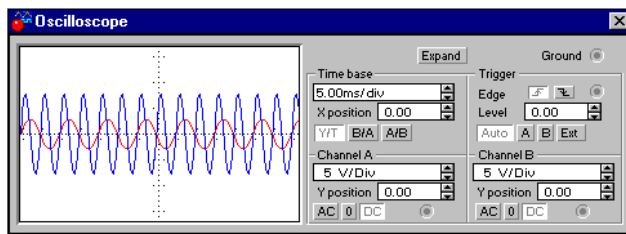
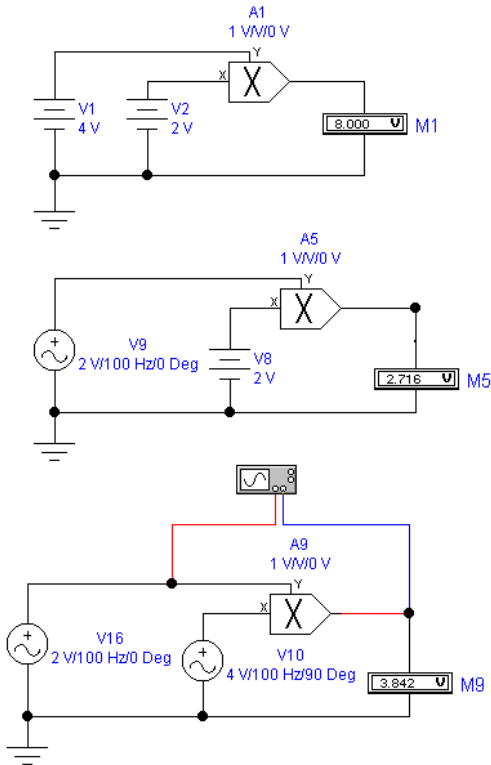

L.1.1 Characteristic Equation

The output voltage is given by:

$$V_{out} = K \left(X_k (V_x + X_{off}) * Y_k (V_y + Y_{off}) \right) + off$$

where

- V_x = input voltage at x
- V_y = input voltage at y

Other symbols used in these equations are defined in “Multiplier Parameters and Defaults”.

L.1.2 Multiplier Parameters and Defaults

| Symbol | Parameter Name | Default | Unit |
|--------|----------------|---------|------|
| k | Output gain | 0.1 | V/V |
| off | Output | 0.0 | V |
| Yoff | Y offset | 0.0 | V |
| Yk | Y gain | 1.0 | V/V |
| Xoff | X offset | 0.0 | V |
| Xk | X gain | 1.0 | V/V |

L.2 Divider

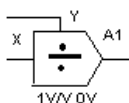

This component divides one voltage (the y input, or numerator) by another (the x input, or denominator).

$$V_o = V_y/V_x$$

Controls Components

You can limit the value of the denominator input to a value above zero by using the parameter XLowLim. This limit is approached through a quadratic smoothing function, the domain of which you can specify as an absolute value in XDS.

In the example shown below, the 120v RMS (339.38v peak to peak) sine wave at the Y input is divided by a 16.96V DC voltage at the X input. The result is $339.38\text{v (peak to peak)} / 16.97\text{V} = 20\text{v peak to peak}$.

If V_x is replaced with a 12v RMS voltage, in phase with V_y , the output will be 10V DC.

CAUTION If the X (denominator) voltage crosses 0v when any voltage is present at the Y (numerator) terminal, the quotient will go to infinity and a large positive or negative “spike” will be observed on the scope.

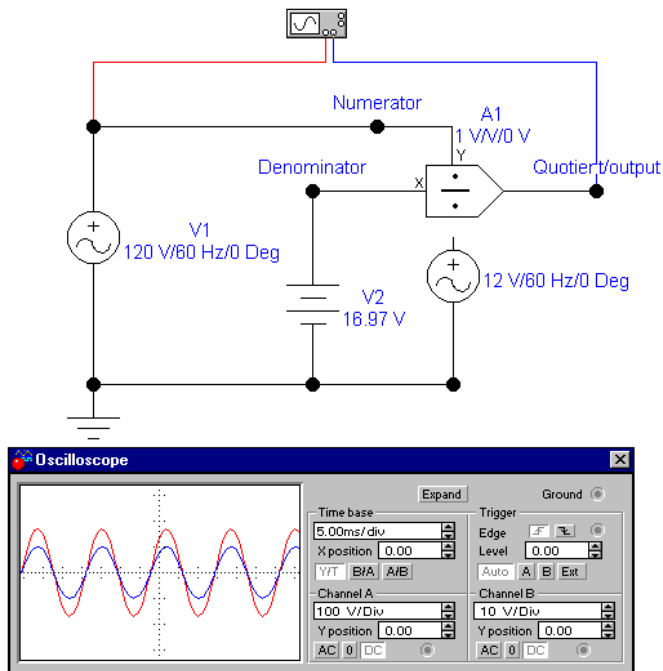

L.2.1 Characteristic Equation

$$V_{out} = \left(\frac{(V_y + Y_{off}) * Y_k}{(V_x + X_{off}) * X_k} \right) * k + off$$

where

V_x = input voltage at x

V_y = input voltage at y

Other symbols used in these equations are defined in the table below.

L.2.2 Divider Parameters and Defaults

| Symbol | Parameter Name | Default | Unit |
|---------|----------------------------------|---------|------|
| k | Output gain | 1 | V/V |
| off | Output offset | 0 | V |
| Yoff | Y (Numerator) offset | 0 | V |
| Yk | Y (Numerator) gain | 1 | V/V |
| Xoff | X (Denominator) offset | 0 | V |
| Xk | X (Denominator) gain | 1 | V/V |
| XLowLim | X (Denominator) lower limit | 100 | pV |
| XSD | X (Denominator) smoothing domain | 100 | pV |

L.3 Transfer Function Block

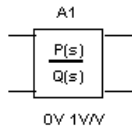

This component models the transfer characteristic of a device, circuit or system in the s domain. The transfer function block is specified as a fraction with polynomial numerators and denominators. A transfer function up to the third order can be directly modeled. This component may be used in DC, AC and transient analyses.

L.3.1 Characteristic Equation

This transfer function model is defined in a form of the rational function:

$$T(s) = \frac{Y(s)}{X(s)} = K * \frac{A_3 s^3 + A_2 s^2 + A_1 s + A_0}{B_3 s^3 + B_2 s^2 + B_1 s + B_0}$$

Transfer functions up to the third order may be modeled.

In the example shown below, the transfer function for a simple first order low pass filter is used. Only the numerator and denominator constants A0 and B0 are required in this case. These are equal to two pi times the cutoff frequency (first pole).

The cursor on the Bode Plotter may be used to confirm first order performance with -3dB at 10kHz. and rolloff of 6dB per octave above 20kHz.

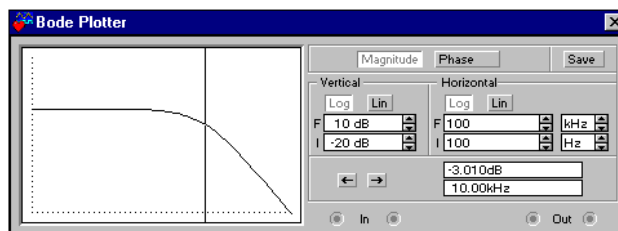
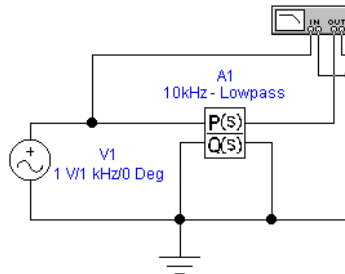

L.3.2 Transfer Function Block Parameters and Defaults

| Symbol | Parameter Name | Default | Unit |
|--------|-------------------------------------|---------|------|
| Vloff | Input voltage offset | 0 | V |
| K | Gain | 1 | V/V |
| VINT | Integrator stage initial conditions | 0 | V |
| w | Denormalized corner frequency | 1 | - |
| A3 | Numerator 3rd order coefficient | 0 | - |
| A2 | Numerator 2nd order coefficient | 0 | - |
| A1 | Numerator 1st order coefficient | 0 | - |
| A0 | Numerator constant | 1 | - |
| B3 | Denominator 3rd order coefficient | 0 | - |
| B2 | Denominator 2nd order coefficient | 0 | - |
| B1 | Denominator 1st order coefficient | 0 | - |
| B0 | Denominator constant | 1 | - |

L.4 Voltage Gain Block

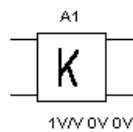

This component multiplies the input voltage by the gain and delivers it to the output. This represents a voltage amplifier function with the gain factor, K, selectable with the Value tab of Circuit/Component Properties. The voltage gain block is used in control systems and analog computing applications.

In the example shown below, the input is a 0.707v RMS (2v peak to peak) sine wave and the gain factor K is set at 5. The output then is K times the input. (.707*5= 3.535v RMS or 10 v peak to peak)

CAUTION Using the default model, as in this example, sine wave inputs may be any value.

Suitable settings of model parameters will allow for virtually unlimited flexibility for practical applications.

Controls

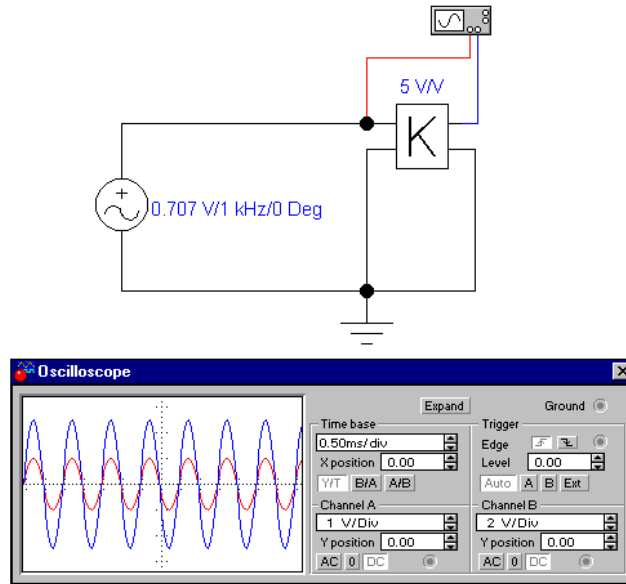

L.4.1 Characteristic Equation

$$V_{out} = K(V_{in} + V_{loff}) + V_{Ooff}$$

L.4.2 Voltage Gain Block Parameters and Defaults

| Symbol | Parameter Name | Default | Unit |
|--------|-----------------------|---------|------|
| K | Gain | 1 | V/V |
| Vloff | Input offset voltage | 0 | V |
| VOoff | Output offset voltage | 0 | V |

L.5 Voltage Differentiator

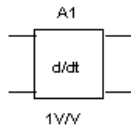

This component calculates the derivative of the input voltage (the transfer function, s) and delivers it to the output. It is used in control systems and analog computing applications.

Differentiation may be described as a “rate of change” function and defines the slope of a curve.

Rate of change = dV/dT

L.5.1 Investigations

L.5.1.1 Sine wave

The slope of a sine wave changes continuously and smoothly. Therefore, the differentiator output should follow the sine shape.

In the example circuit shown below, if you change frequency from 10Hz. to 100Hz., the rate of change of the waveform will increase by a factor of 10. The differentiator output will also increase by the same factor. When investigating, note also a 90 degree phase shift from input to output.

L.5.1.2 Triangle waveforms

In an ideal triangle waveform the rising and falling slopes are constant with an abrupt change taking place at the peaks.

Since the rate of change (slope) during rise and fall are constant, the differential result is also constant.

The reversal of slope at the peaks (from rise to fall/fall to rise) produces a large instantaneous change in the differentiator output, resulting in a square wave output.

In the example circuit, as for the sine wave, if you change frequency from 10Hz. to 100Hz., the rate of change of the waveform will increase by a factor of 10. The differentiator output will also increase by the same factor.

L.5.1.3 Square waves

In an ideal square wave, the change takes place only at the rising and falling edges. The change is instantaneous. This instantaneous rate of change

($dV/dT = dV/0$)

will produce an infinitely large output from a differentiator.

Since ideal square or pulse waveforms, as produced by the function generator in Multisim, have zero rise and fall times, the result of differentiation is infinite ($dV/0 = \text{infinity}$).

In the example circuit, outputs from the differentiator are limited to +/-5 kilo volts. With the ideal square wave input, the differentiator output will be seen to be +/-5kV.

All real square wave and pulse signals have finite rise times, however small.

To introduce finite rise and fall times into the input to the differentiator, in order to investigate realistic situations, use an RC network placed in series with the function generator.

Note Since the rise and fall times are fixed, the differentiator output does not change with change of input frequency as for the sine and triangle waveforms.

Changing the RC time constant and comparing differentiator output will illustrate this point.

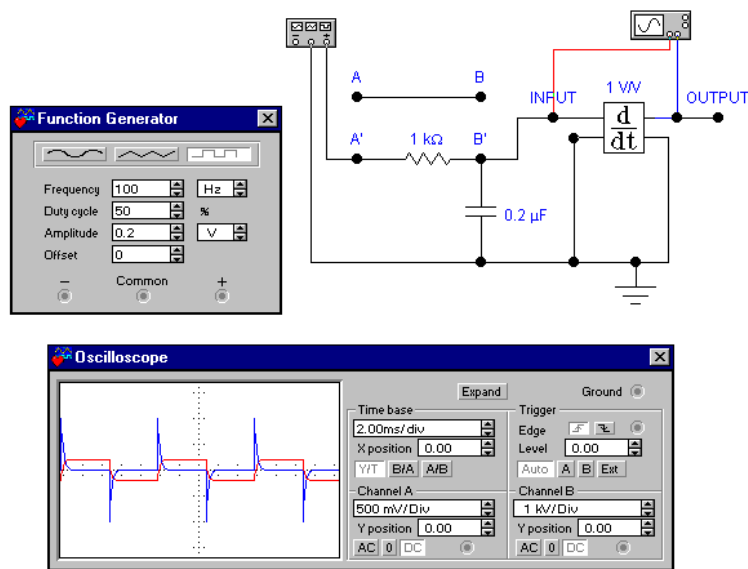

L.5.2 Characteristic Equation

$$V_{out}(t) = K \frac{dV_i}{dt} + V_{off}$$

L.5.3 Voltage Differentiator Parameters and Defaults

| Symbol | Parameter Name | Default | Unit |
|--------|---------------------------------|---------|------|
| K | Gain | 1 | V/V |
| VOff | Output offset voltage | 0 | V |
| VL | Output voltage lower limit | -1e+12 | V |
| Vu | Output voltage upper limit | 1e+12 | V |
| Vs | Upper and lower smoothing range | 1e-06 | V |

L.6 Voltage Integrator

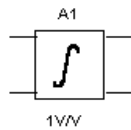

This component calculates the integral of the input voltage (the transfer function, $1/s$) and delivers it to the output. It is used in control systems and analog computing applications.

The true integrator function continuously adds the area under a curve for a specified time interval.

For waveforms that are symmetrical about the zero axis, area above and below the axis is zero and the resulting integrator output is zero.

For waveforms that are not symmetrical about the zero axis, the “areas” will be different. If area above the axis is greater, integrator output will rise. If area is less, integrator output will fall.

L.6.1 Investigations

1. In the initial circuit, the input signal is symmetrical (+/- 5V) about the zero axis and the integrator output is zero for sine, square and triangle waveforms.
2. To make the waveforms unsymmetrical about the zero axis use the OFFSET control on the function generator. Setting the OFFSET equal to the AMPLITUDE setting will reference the input to ground (0V).

In this case, the output is always positive. When output is high, “area” is continually added. Output will rise indefinitely.

Changing frequency changes the area. Therefore, in the case of lower frequencies, output rises faster.

Controls

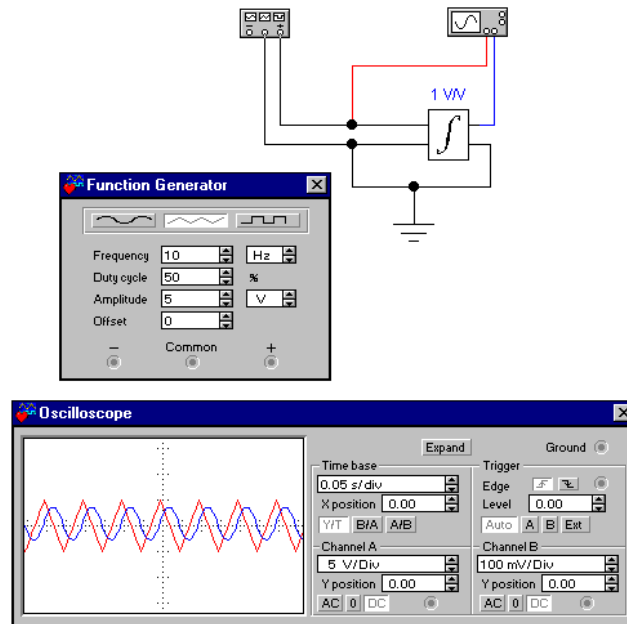

L.6.2 Characteristic Equation

$$V_{out}(t) = K \int_0^t (V_i(t) + V_{loff}) dt + V_{Oic}$$

L.6.3 Voltage Integrator Parameters and Defaults

| Symbol | Parameter Name | Default | Unit |
|--------|---------------------------------|---------|------|
| Vloff | Input offset voltage | 0 | V |
| K | Gain | 1 | V/V |
| VI | Output voltage lower limit | -1e+12 | V |
| Vu | Output voltage upper limit | 1e+12 | V |
| Vs | Upper and lower smoothing range | 1e-06 | V |
| VOic | Output initial conditions | 0 | V |

L.7 Voltage Hysteresis Block

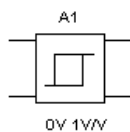

This component is a simple buffer stage that provides hysteresis of the output with respect to the input. V_{iL} and V_{iH} specify the center voltage or **current** inputs about which the hysteresis effect operates. The output values are limited to V_{oL} and V_{oH} . The hysteresis value, H , is added to V_{iL} and V_{iH} in order to specify the points at which the slope of the hysteresis function would normally change abruptly as the input transitions from low to high values. The slope of the hysteresis function is smoothly varied whenever ISD is set greater than zero.

This component can be used to simulate a non-inverting comparator in which the comparison threshold is changed each time the input crosses the threshold in effect at that instant. As the output changes state (high to low or low to high), the threshold voltage is changed internally in such a manner that the input must continue to change until it reaches the new threshold.

In the example circuit shown below, the hysteresis value is set to 5V. This means that the two comparison thresholds at which the output changes are +5V and -5V.

As shown, the input triangle waveform rises from 0V and the output is at its lowest value (0V in this case), as the input crosses +5V (the upper threshold in comparator terms) the output changes to its highest value(+2V in this case). Internally in the hysteresis block the threshold is now changed to -5V, (the lower threshold).

The output continues to rise to a peak and then starts to decrease.

Note The output changes only when the input crosses -5V. Internally, the threshold is changed again to the upper threshold and the process repeats.

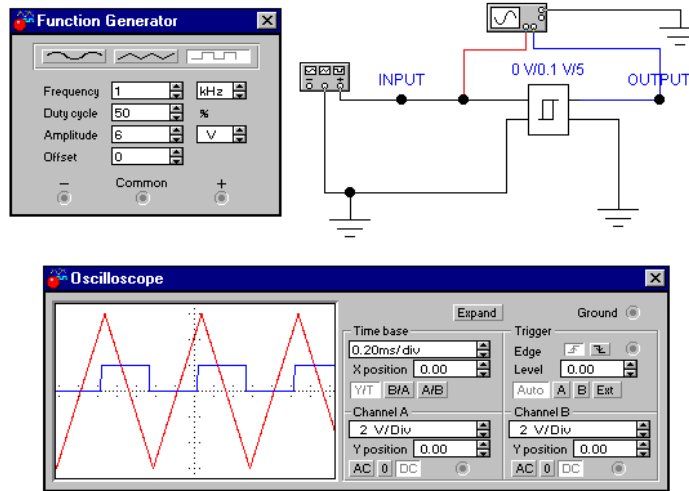

L.7.1 Hysteresis Block Parameters and Defaults

| Symbol | Parameter Name | Default | Unit |
|--------|--------------------------|---------|------|
| ViL | Input low value | 0 | V |
| ViH | Input high value | 1 | V |
| H | Hysteresis | 0.1 | - |
| VoL | Output lower limit | 0 | V |
| VoH | Output upper limit | 1 | V |
| ISD | Input smoothing domain % | 1 | - |

L.8 Voltage Limiter

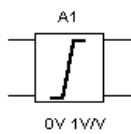

This is a voltage “clipper”. The output voltage excursions are limited, or clipped, at predetermined upper and lower voltage levels while input-signal amplitude varies widely.

In the example shown below, the upper voltage limit is set to +5V and the lower limit is set to -5 volts. These settings provide symmetrical clipping on the positive and negative peak excursions of the input waveform when these peaks exceed the set limit (clipping) values.

The 10 v RMS (14.14v peak) input is limited at +/-5V.

Note If the input peak voltages are within the set limiting voltages, the input signal is passed through the limiter circuit undistorted.

Unsymmetrical clipping is selected by setting the limit voltages to different values (i.e. +5V and -2V). This technique may be used to produce non-standard waveshapes, starting with sine, triangle sawtooth and other symmetrical waveforms.

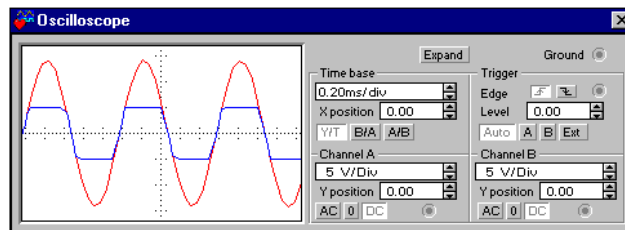
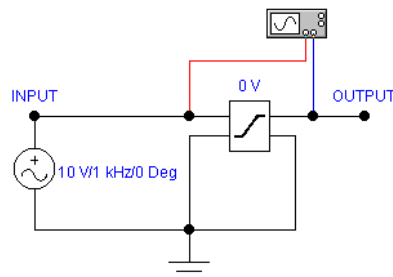

L.8.1 Characteristic Equation

$$V_{OUT} = K(V_{in} + V_{loff}) \text{ for } V_{min} \leq V_{out} \leq V_{max}$$

$$V_{OUT} = V_{max} \quad \text{for } V_{OUT} > V_{max}$$

$$V_{OUT} = V_{min} \quad \text{for } V_{OUT} < V_{min}$$

L.8.2 Voltage Limiter Parameters and Defaults

| Symbol | Parameter Name | Default | Unit |
|--------|---------------------------------------|---------|------|
| Vloff | Input offset voltage | 0 | V |
| K | Gain | 1 | V/V |
| Vl | Output voltage lower limit | 0 | V |
| Vu | Output voltage upper limit | 1 | V |
| Vs | Upper and lower limit smoothing range | 1e-06 | V |

L.9 Current Limiter Block

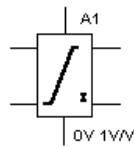

This component models the behavior of an operational amplifier or comparator at a high level of abstraction. All of its pins act as inputs; three of them also act as outputs. The component takes as input a voltage value from the “in” connector. It then applies the offset and gain, and derives from it an equivalent internal voltage, V_{eq} , which it limits to fall between the positive and negative power supply inputs. If V_{eq} is greater than the output voltage seen on the “out” connector, a sourcing current will flow from the output pin. Otherwise, if V_{eq} is less than the output voltage, a sinking current will flow into the output pin.

Depending on the polarity of the current flow, either a sourcing or a sinking resistance (R_{src} or R_{snk}) value is applied to govern the output voltage/output current relationship. The chosen resistance will continue to control the output current until it reaches a maximum value specified by either $ISrcL$ or $ISnkL$. The latter mimics the current limiting behavior of many operational amplifier output stages.

During operation, the output current is reflected either in the positive or the negative power supply inputs, depending on the polarity of the output current. Thus, realistic power consumption as seen in the supply rails is modeled.

ULSR controls the voltage below positive input power and above negative input power beyond which $V_{eq} = k(\text{input voltage} + \text{Off})$ is smoothed. ISrcSR specifies the current below ISrcL at which smoothing begins, and specifies the current increment above zero input current at which positive power begins to transition to zero. ISnkSR serves the same purpose with respect to ISnkL and negative power. VDSR specifies the incremental value above and below $(V_{eq} - \text{output voltage}) = 0$ at which output resistance will be set to Rsrc and Rsnk, respectively. For values of $(V_{eq} - \text{output voltage})$ less than VDSR and greater than $-VDSR$, output resistance is interpolated smoothly between Rsrc and Rsnk.

The current limiter block is also a representation of an operational amplifier with respect to the sourcing and sinking of current at the output and supply terminals.

If the current being sinked/sourced to the load is less than the rated maximum, as determined from rated maximum sink/source specifications for a particular opamp, operation of the opamp circuit will be as expected.

If the current to be sinked/sourced is greater than the rated maximum, as determined by a larger than normal input to the opamp circuit, the current limiter will limit current to the specified safe maximum value, thus protecting the opamp and associated circuitry from damage.

In the example circuit shown below, the sink and source current limits are set to 2 mA and the circuit gain (K) is set to 1. For this case, output current should then be $I_{load} = V_{in} * K / R_{load}$.

The switch, activated by pressing S, applies either a positive or negative input to the 'op-amp' circuit. These input levels are such that the output current would be in excess of the rated value of 2.0mA. The current limit function limits the source or sink output to 2.0 mA.

If the input levels are reduced to 2V or less, then the output current will be as expected at V_{in} / R_{load} .

A sine wave input of 1.4v RMS or less will be passed undistorted through the “amplifier” while inputs greater than 1.4 v RMS will show limiting (clipping) at the peaks.

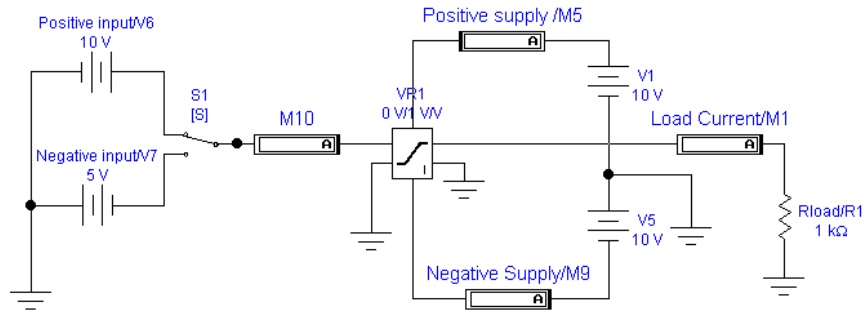

L.9.1 Current Limiter Parameters and Defaults

| Symbol | Parameter Name | Default | Unit |
|--------|-------------------------------------------------|---------|-----------|
| Off | Input offset | 0 | V |
| k | Gain | 1 | V/V |
| Rsrc | Sourcing resistance | 1 | W |
| Rsink | Sinking resistance | 1 | W |
| ISrcL | Current sourcing limit | 10 | mA |
| ISnkL | Current sinking limit | 10 | mA |
| ULSR | Upper and lower power supply smoothing range | 1 | μV |
| ISrcSR | Sourcing current smoothing range | 1 | nA |
| ISnkSR | Sinking current smoothing range | 1 | nA |
| VDSR | Internal/external voltage delta smoothing range | 1 | $n\Omega$ |

L.10 Voltage-Controlled Limiter

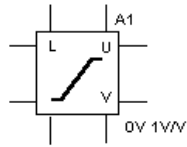

A voltage “clipper”. This component is a single input, single output function. The output is restricted to the range specified by the output lower and upper limits. Output smoothing occurs within the specified range. The voltage-controlled limiter will operate in DC, AC and transient analysis modes.

The component tests the values of the upper and lower limit control inputs to make sure that they are spaced far enough apart to guarantee the existence of a linear range between them. The range is calculated as the difference between (upper limit control input (U) - VoUD - ULSR) and (lower limit control input (L) + VoLD + ULSR) and must be greater than or equal to zero.

The limiting levels may be individually set at fixed values or one or both limiting levels may be controlled by a variable voltage, depending on the desired application.

In the circuit shown below, the upper voltage limit is set by adjusting the potentiometer supplying the Upper terminal on the VCL. The lower voltage limit is set by adjusting the potentiometer supplying the Lower terminal on the VCL. The potentiometers are adjusted by pressing U or SHIFT-U for the upper limit and L or SHIFT-L for the lower limit.

These settings may be adjusted to provide symmetrical or unsymmetrical clipping on the positive and negative peak excursions of the input waveform when these peaks exceed the set limit (clipping) values.

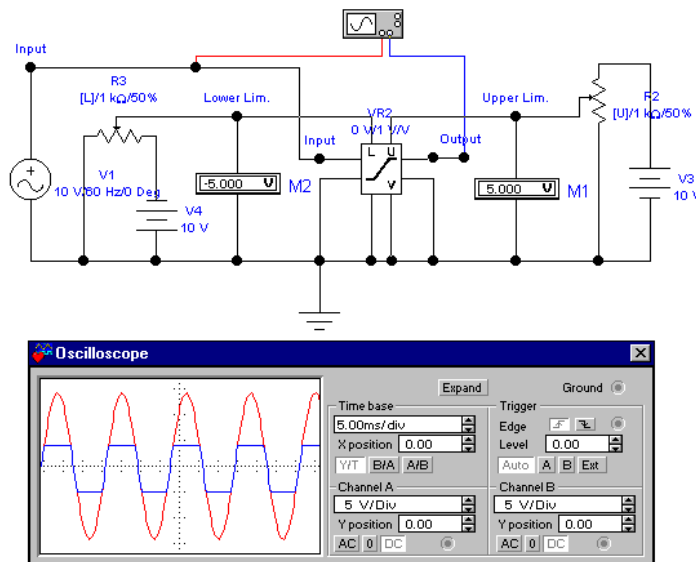

L.10.1 Voltage-Controlled Limiter Parameters and Defaults

| Symbol | Parameter Name | Default | Unit |
|--------|---------------------------------|---------|---------|
| ViOff | Input offset | 0 | V |
| k | Gain | 1 | V/V |
| VoUD | Output upper delta | 0 | V |
| VoLD | Output lower delta | 0 | V |
| ULSR | Upper and lower smoothing range | 1 | μV |

L.11 Voltage Slew Rate Block

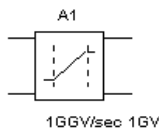

This component limits the absolute slope of the output, with respect to time, to some maximum or value. You can accurately model actual slew rate effects of over-driving an amplifier circuit by cascading the amplifier with this component. Maximum rising and falling slope values are expressed in volts per second.

The slew rate block will continue to raise or lower its output until the difference between input and output values is zero. After, it will resume following the input signal unless the slope again exceeds its rise or fall slope limits.

This component provides for introduction of selectable rising and falling slew rates (rise and fall times on a pulse waveform) for analysis of pulse and analog circuits.

With an ideal pulse or analog input to block the effect of slew rate on a logic circuit or analog amplifier, (discrete component or op-amp) output may be investigated.

In the example shown below, the function generator may be set for either square wave or sine wave output.

A slew rate of 8000V/sec for rising slope and 6000V/sec for falling slope shows as rise and fall time on an ideal 80Hz. square wave input. Signal degradation as a result of slew rate occurs when frequency is increased.

Switching the function generator to sine wave output 60 Hz. does not result in distortion. However, as frequency is increased, slew rate distortion on a sine wave will become evident at 200 Hz. and above. As frequency is increased, the sine wave deteriorates to a triangle shape.

A more serious degradation of output as a result of slew rate occurs when the input frequency is doubled to 200Hz.

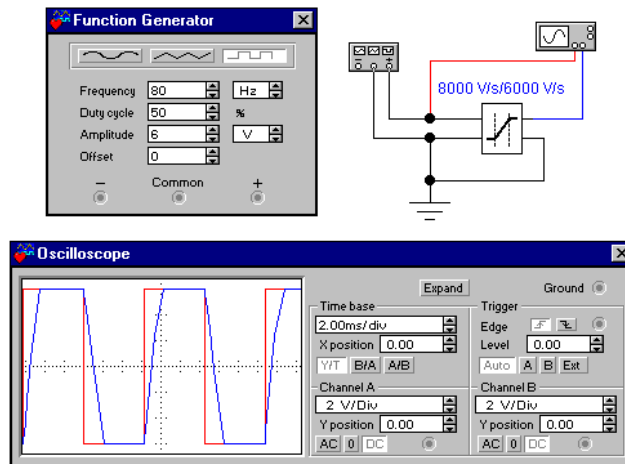

Controls

L.11.1 Voltage Slew Rate Block Parameters and Defaults

| Symbol | Parameter Name | Default | Unit |
|--------|-----------------------------|---------|------|
| RSMMax | Maximum rising slope value | 1 | GV/s |
| FSMMax | Maximum falling slope value | 1 | GV/s |

L.12 Three-Way Voltage Summer

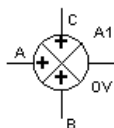

This component is a math functional block that receives up to three voltage inputs and delivers an output equal to their arithmetic sum. Gain for all three inputs as well as the summed output may be set to match any three input summing application.

In the example shown below, all gains are set to unity.

Controls Components

The summer may be used to illustrate the result of adding harmonically related sine wave components which make up a complex waveform (the first three terms in the Fourier expression defining the waveform).

In the example, a fundamental frequency of 60 Hz. and the third and fifth harmonics (in phase) may be progressively added to illustrate the basic makeup of a square wave.

Amplitude and phase of any of the signals may be varied to experiment further.

CAUTION The switches should not be operated while a solution is in progress. This will result in solution error messages. Allow the solution to pause (or pause it by clicking on the solution switch). Operate a switch to add the desired harmonic, and then solve the circuit again.

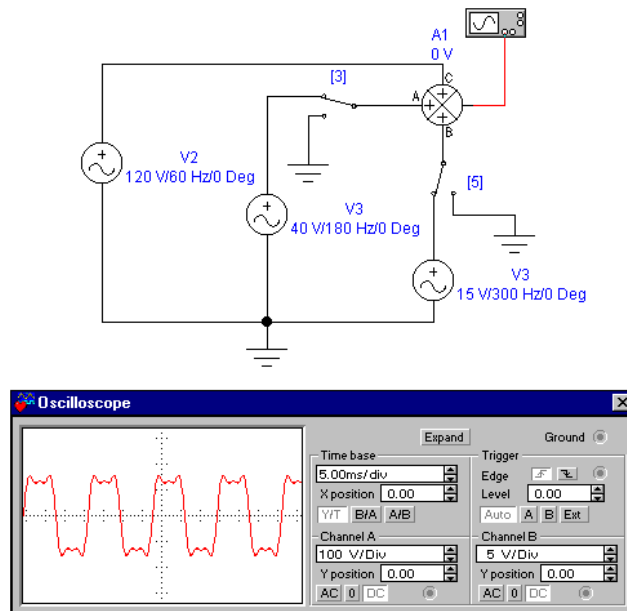

L.12.1 Characteristic Equation

$$V_{OUT} = K_{OUT}[K_A(V_A + V_{Aoff}) + K_B(V_B + V_{Boff}) + K_C(V_C + V_{Coff})] + V_{0off}$$

L.12.2 Summer Parameters and Defaults

| Symbol | Parameter Name | Default | Unit |
|--------|------------------------|---------|------|
| VAoff | Input A offset voltage | 0 | V |
| VBoff | Input B offset voltage | 0 | V |
| VCoff | Input C offset voltage | 0 | V |
| Ka | Input A gain | 1 | V/V |
| Kb | Input B gain | 1 | V/V |
| Kc | Input C gain | 1 | V/V |
| Kout | Output gain | 1 | V/V |
| VOoff | Output offset voltage | 0 | V |

Controls Components

Controls

Appendix M

RF Components

| | | |
|-----|----------------------|-----|
| M.1 | RF Capacitor | M-1 |
| M.2 | RF Inductor | M-1 |
| M.3 | RF Bipolar Resistors | M-2 |
| M.4 | RF MOS_3TDN | M-2 |
| M.5 | Tunnel Diode | M-3 |
| M.6 | Strip Line | M-3 |



RF

Appendix M RF Components

M.1 RF Capacitor

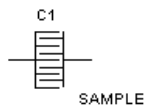

RF capacitors at RF frequencies show behaviors different from the regular capacitors at low frequencies. RF capacitors at RF frequencies act as a combination of a number of transmission lines, waveguides, discontinuities, and dielectrics. The dielectric layers are usually very thin (typically 0.2 M μ m).

The equations governing these types of capacitors follow those of transmission lines; therefore, each RF capacitor is described by inductance per unit length, resistance per unit length, shunt capacitance per unit length, and shunt conductance per unit length. Depending on the type of the technology used, practical capacitance values are in the range between several picofarads and several nanofarads. These capacitors are used for coupling or bypassing for frequencies up to approximately 20 GHz.

One type of RF capacitor is called an interdigital capacitor. Both conductors of the capacitor are in the same plane, which is the top surface of the dielectric substrate used. Each conductor, or external node of the capacitor, is structured by connecting a number of transmission lines in parallel. In other words, the planar structure uses N thin parallel conducting strips of length L, linked alternately to one or other two strips of length W running perpendicularly alongside them, and the whole structure is deposited on a substrate, often of alumina. Capacitors of this type appear to be lumped up to 3 GHz and values from 0.1 to 10 pF can be achieved. However, because of their structure, they require a relatively large area.

M.2 RF Inductor

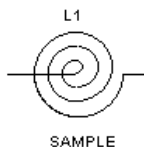

From many types of RF inductors, spiral inductors provide higher inductance values and higher Qs. The spiral inductor is a technique of forming a planar inductor in a small place. The shape is described by an increasing radius with angle: i.e. $R = r/I + k\theta$

The equivalent circuit is a combination of series resistor (due to skin effect) and inductor, and shunt capacitors (due to the distance between the surface which embraces the conductor, and the ground plane). The quality of the inductor, usually noted as Q , is higher for spiral inductors than those of other types of inductors, such as the rectangular spiral.

M.3 RF Bipolar Resistors

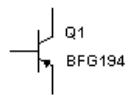

Basic operation of an RF bipolar transistor is identical to that of transistors designed for low frequencies. RF transistors, however, have a higher maximum operating frequency (W_p), depending on base and collector transit and charging times. To achieve this, the physical size of emitter/base/collector areas at the layout level are minimized. However, reduction in the base area is limited by the technology used to fabricate the transistor. Reduction in the collector area is limited by the maximum tolerable voltage at the collector terminal. To achieve maximum power output, the emitter periphery area should be as large as possible. Because of these limitations, a special structure for bipolar transistors is used. This structure is commonly referred to as an interdigital bipolar transistor.

M.4 RF MOS_3TDN

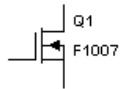

RF FETs have a different type of carrier than bipolar transistors. Only the majority carriers selected for FET should have better transport properties (such as high mobility, velocity, diffusion coefficient). For this reason, RF FETs are fabricated on n-type materials since electrons have better properties.

The two most important parameters are the gate length and width. A reduction in the gate length will improve the gain, noise figure and frequency of operation. Increasing the gate width will increase the RF power capability. That is why typical power FETs have multiple gate fingers, interconnected via air bridges, with a total width of about 400 to 1000 μm .

The model parameters for RF FET transistors can be obtained using measured data for DC and RF S-parameters. The equivalent circuit model should have almost identical DC and RF S-parameters.

M.5 Tunnel Diode



A tunnel diode is a heavily doped diode that is used in high-frequency communications circuits for applications such as amplifiers, oscillators, modulators, and demodulators. The unique operating curve of the tunnel diode is a result of the heavy doping used in the manufacturing of the diode. The tunnel diode is doped about one thousand times as heavily as standard pn -junction diode

The tunnel diode is different from any other diode because of its negative-resistance region. In this area, forward voltage and current are inversely proportional. For example, an increase in forward voltage would result in a reduction in diode current.

A tunnel diode can also be used to generate a sinusoidal voltage using a DC supply and a few passive elements.

M.6 Strip Line

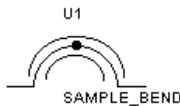

Stripline is one of the most commonly used transmission lines at microwave frequencies. Stripline is coined for ground-conductor-ground transmission line with a dielectric (normally air) in between. Due to the multiplicity of the circuit functions, substrate, technologies, and frequency bands, there is a wide range of stripline conductors. For example, microstrip lines are a special type of stripline where the upper ground is placed at infinity. Depending on the position of the stripline conductors, the shape of the conductor, and the thickness of the conductor, the equations governing the behavior of one stripline to another differ. For example, the centered stripline (often called Tri-Plate line), is a stripline where the conductance is placed symmetrically in each position (from top, bottom, left, and right). Another example is the Zero-Thickness stripline which is a very good approximation for striplines in which the thickness of the conductor is negligible compared to the distance it has from the ground planes.

RF

Appendix N

Electro-Mechanical Components

| | | |
|-----|--------------------|-----|
| N.1 | Switches | N-1 |
| N.2 | Line Transformer | N-1 |
| N.3 | Coils, Relays | N-2 |
| N.4 | Timed Contacts | N-2 |
| N.5 | Protection Devices | N-2 |
| N.6 | Output Devices | N-2 |
| N.7 | Push Buttons | N-3 |
| N.8 | Pilot Lights | N-3 |
| N.9 | Terminals | N-3 |

Electro-mechanical

Electronics Workbench

Appendix N Electro-Mechanical Components

N.1 Switches

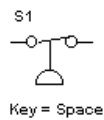

Switches can be closed or opened (turned on or off) by pressing a key on the keyboard. You specify the key that controls the switch by typing its name in the Value tab of the component's Properties screen. For example, if you want the switch to close or open when the spacebar is pressed, type space in the Value tab, then click **OK**.

A list of possible key names is shown below:

| To use... | Type |
|----------------|------------------------|
| letters a to z | the letter (e.g. a) |
| Enter | enter |
| spacebar | space |

N.2 Line Transformer

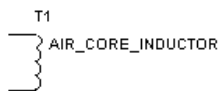

Line Transformers are simplified transformers intended for power applications where the primary coils is connected to either 120 or 220 VAC. They will perform step up or step down functions plus several specialized functions of voltage and current measurement.

N.3 Coils, Relays

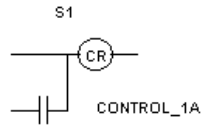

Multisim includes the following coils and relays:

- motor starter coil
- forward or fast starter coil
- reverse starter coil
- slow starter coil
- control relay
- time delay relay.

N.4 Timed Contacts

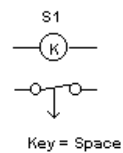

Multisim includes the following timed contacts:

- normally open timed closed
- normally open timed closed.

N.5 Protection Devices

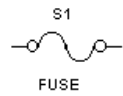

Multisim includes the following protection devices

- fuse
- overload
- overload thermal
- overload magnetic
- ladder logic overload

N.6 Output Devices

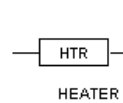

Multisim includes the following output devices:

- light indicator
- motor
- DC motor armature
- 3 phase motor

- heater
- LED indicator
- solenoid.

N.7 Push Buttons

Multisim includes the following push button switches:

- N.O.
- N.C.
- N.O. & N.C. (double circuit)
- mushroom head
- wobble stick
- illuminated.

Push button switches are momentary switches which need to be activated only for the duration during which the user manually acts on them.

N.8 Pilot Lights

Multisim includes the following pilot lights:

- non push-to-test
- push-to-test.

N.9 Terminals

Multisim includes the following terminals:

- power terminals
- control terminals N.O.
- control terminals N.C.
- coil terminals.

Electro-Mechanical Components

Electro-mechanical

Appendix O

Functions (4000 Series)

| | | |
|--------|------------------------------------|------|
| O.1 | CMOS | O-1 |
| O.1 | Power-Supply Voltage | O-2 |
| O.1 | Logic Voltage Levels | O-2 |
| O.1 | Noise Margins | O-2 |
| O.1 | Power Dissipation | O-2 |
| O.2 | 4000 Series ICs | O-2 |
| O.2.1 | 4000 (Dual 3-In NOR and INVERTER) | O-3 |
| O.2.2 | 4001 (Quad 2-In NOR) | O-3 |
| O.2.3 | 4002 (Dual 4-In NOR) | O-4 |
| O.2.4 | 4007 (Dual Com Pair/Inv) | O-4 |
| O.2.5 | 4008 (4-bit Binary Full Adder) | O-4 |
| O.2.6 | 4010 (Hex BUFFER) | O-5 |
| O.2.7 | 40106 (Hex INVERTER (Schmitt)) | O-5 |
| O.2.8 | 4011 (Quad 2-In NAND) | O-6 |
| O.2.9 | 4012 (Dual 4-In NAND) | O-6 |
| O.2.10 | 4013 (Dual D-type FF (+edge)) | O-7 |
| O.2.11 | 4014 (8-bit Static Shift Reg) | O-7 |
| O.2.12 | 4015 (Dual 4-bit Static Shift Reg) | O-8 |
| O.2.13 | 40160 (4-bit Dec Counter) | O-9 |
| O.2.14 | 40161 (4-bit Bin Counter) | O-10 |
| O.2.15 | 40162 (4-bit Dec Counter) | O-10 |
| O.2.16 | 40163 (4-bit Bin Counter) | O-10 |
| O.2.17 | 4017 (5-stage Johnson Counter) | O-11 |
| O.2.18 | 40174 (Hex D-type Flip-flop) | O-12 |
| O.2.19 | 40175 (Quad D-type Flip-flop) | O-12 |
| O.2.20 | 4018 (5-stage Johnson Counter) | O-13 |
| O.2.21 | 4019 (Quad 2-In MUX) | O-14 |
| O.2.22 | 40192 (4-bit Dec Counter) | O-14 |
| O.2.23 | 40193 (4-bit Bin Counter) | O-15 |
| O.2.24 | 40194 (4-bit Shift Register) | O-15 |
| O.2.25 | 40195 (4-bit Shift Register) | O-15 |

| | | |
|--------|-----------------------------------------|------|
| O.2.26 | 4020 (14-stage Bin Counter) | O-16 |
| O.2.27 | 4021 (8-bit Static Shift Register) | O-16 |
| O.2.28 | 4023 (Tri 3-In NAND) | O-16 |
| O.2.29 | 4024 (7-stage Binary Counter) | O-17 |
| O.2.30 | 40240 (Octal Inv Buffer) | O-18 |
| O.2.31 | 40244 (Octal Non-inv Buffer) | O-18 |
| O.2.32 | 40245 (Octal Bus Transceiver) | O-18 |
| O.2.33 | 4025 (Tri 3-In NOR) | O-19 |
| O.2.34 | 4027 (Dual JK FF (+edge, pre, clr)) | O-19 |
| O.2.35 | 4028 (1-of-10 Dec) | O-20 |
| O.2.36 | 4029 (4-bit Bin/BCD Dec Counter) | O-21 |
| O.2.37 | 4030 (Quad 2-In XOR) | O-21 |
| O.2.38 | 4032 (Triple Serial Adder) | O-22 |
| O.2.39 | 4035 (4-bit Shift Register) | O-22 |
| O.2.40 | 40373 (Octal Trans Latch) | O-23 |
| O.2.41 | 40374 (Octal D-type Flip-flop) | O-24 |
| O.2.42 | 4038 (Triple Serial Adder) | O-24 |
| O.2.43 | 4040 (12-stage Binary Counter) | O-24 |
| O.2.44 | 4041 (Quad True/Complement BUFFER) | O-25 |
| O.2.45 | 4042 (Quad D-latch) | O-25 |
| O.2.46 | 4043 (Quad RS latch w/3-state Out) | O-26 |
| O.2.47 | 4044 (Quad RS latch w/3-state Out) | O-26 |
| O.2.48 | 4049 (Hex INVERTER) | O-26 |
| O.2.49 | 4050 (Hex BUFFER) | O-27 |
| O.2.50 | 4066 (Quad Analog Switches) | O-27 |
| O.2.51 | 4068 (8-In NAND) | O-28 |
| O.2.52 | 4069 (Hex INVERTER) | O-28 |
| O.2.53 | 4070 (Quad 2-In XOR) | O-28 |
| O.2.54 | 4071 (Quad 2-In OR) | O-29 |
| O.2.55 | 4072 (Dual 4-In OR) | O-29 |
| O.2.56 | 4073 (Tri 3-In AND) | O-30 |
| O.2.57 | 4075 (Tri 3-In OR) | O-31 |
| O.2.58 | 4076 (Quad D-type Reg w/3-state Out) | O-31 |
| O.2.59 | 4077 (Quad 2-In XNOR) | O-32 |
| O.2.60 | 4078 (8-In NOR) | O-32 |
| O.2.61 | 4081 (Quad 2-In AND) | O-33 |
| O.2.62 | 4082 (Dual 4-In AND) | O-33 |
| O.2.63 | 4085 (Dual 2-Wide 2-In AND-OR-INVERTER) | O-34 |
| O.2.64 | 4086 (4-Wide 2-In AND-OR-INVERTER) | O-36 |
| O.2.65 | 4093 (Quad 2-In NAND (Schmitt)) | O-36 |
| O.2.66 | 4094 (8-stage Serial Shift Register) | O-37 |
| O.2.67 | 4099 (8-bit Latch) | O-38 |

| | | |
|--------|----------------------------------------------|------|
| O.2.68 | 4502 (Strobed hex INVERTER) | O-38 |
| O.2.69 | 4503 (Tri-state hex BUFFER w/Strobe) | O-39 |
| O.2.70 | 4508 (Dual 4-bit latch) | O-39 |
| O.2.71 | 4510 (BCD up/down Counter) | O-40 |
| O.2.72 | 4511(BCD-to-seven segment latch/Dec) | O-41 |
| O.2.73 | 4512 (8-In MUX w/3-state Out) | O-42 |
| O.2.74 | 4514 (1-of-16 Dec/DEMUX w/Input latches) | O-43 |
| O.2.75 | 4515 (1-of-16 Dec/DEMUX w/Input latches) | O-44 |
| O.2.76 | 4516 (Binary up/down Counter) | O-45 |
| O.2.77 | 4518 (Dual BCD Counter) | O-46 |
| O.2.78 | 4519 (Quad Multiplexer) | O-47 |
| O.2.79 | 4520 (Dual Binary Counter) | O-47 |
| O.2.80 | 4522 (4-bit BCD Down Counter) | O-48 |
| O.2.81 | 4526 (4-bit Bin Down Counter) | O-48 |
| O.2.82 | 4531 (13-input Checker/Generator) | O-48 |
| O.2.83 | 4532 (8-bit Priority Enc) | O-49 |
| O.2.84 | 4539 (Dual 4-input Multiplexer) | O-50 |
| O.2.85 | 4543 (BCD-to-seven segment latch/dec/driver) | O-50 |
| O.2.86 | 4544 (BCD-to-seven segment latch/dec) | O-52 |
| O.2.87 | 4555 (Dual 1-of-4 Dec/DEMUX) | O-53 |
| O.2.88 | 4556 (Dual 1-of-4 Dec/DEMUX) | O-53 |
| O.2.89 | 4585 (4-bit Comparator) | O-54 |

Appendix O Functions (4000 Series)

O.1 CMOS



The complementary MOS (CMOS) logic family uses both P- and N-channel MOSFETS in the same circuit. CMOS is faster and consumes less power than the other MOS families.

CMOS ICs provide not only all of the same logic functions available in TTL, but also several special functions not provided by TTL.

The 74C series is pin-compatible (pin configuration of the two ICs are the same) with and functionally equivalent to TTL devices with the same number. Many but not all functions that are available in TTL are also available in the 74C series. It is possible then to replace some TTL circuits with an equivalent design.

The 74HC/HCT series is an improved version of the 74C series. It has a tenfold increase in switching speed compared to the 74LS devices and a higher output current capability than that of the 74C. The 74HC/HCT ICs are pin-compatible with and functionally equivalent to TTL ICs with the same number. 74HCT devices are electrically compatible with TTL, but devices from the 74C series are not.

The 74AC/ACT series, often referred to as ACL, for advanced CMOS logic, is functionally equivalent to the various TTL series, but is not pin-compatible with TTL. 74AC devices are not electrically compatible with TTL; however, the 74ACT devices can be connected directly to TTL. The 74AC/ACT series has advantages over the HC series in the areas of noise immunity, propagation delay, and maximum clock speed. The device numbering for this series differs from TTL, 74C and 74HC/HCT numbering.

The 74AHC is the newest series of CMOS devices. The devices in this series are three times faster than and can replace the HC series devices.

Power-Supply Voltage

The 4000/14000 series and 74C series devices can operate with V_{DD} values ranging from 3 to 15 V. The 74HC/HCT and 74AC/ACT series operate over a range of supply voltages between 2 and 6 V.

Logic Voltage Levels

The input and output voltage levels are different for each CMOS series. The V_{OL} for the CMOS devices is close to 0 V and the V_{ON} is close to 5 V. The required input voltage levels are greater for CMOS than for TTL, except for the 74 ACT series. These series are designed to be electrically comparable with TTL, so they must accept the same input voltage levels as TTL.

Noise Margins

The CMOS devices have greater noise margins than TTL.

Power Dissipation

The power dissipation of a CMOS logic circuit is very low when the circuit is in a static state. The power dissipation of a CMOS IC increases in proportion to the frequency at which the circuits are switching states.

0.2 4000 Series ICs

The 4000 component in the parts bin is a generic IC, or template. It has no pins or labels and cannot be wired into a circuit.

To use an IC, drag the template onto the circuit window. A list of available ICs for this family appears. Select the IC you want to include in your circuit. The correct graphic will appear containing labels and pins.

O.2.1 4000 (Dual 3-In NOR and INVERTER)



Logic function:

$$O_1 = \overline{I_1 + I_2 + I_3}$$

$$O_2 = \overline{I_4 + I_5 + I_6}$$

$$O_3 = \overline{I_7}$$

NOR gate truth table:

| I1 | I2 | I3 | O1 |
|----|----|----|----|
| 0 | 0 | 0 | 1 |
| 1 | 0 | 0 | 0 |
| 0 | 1 | 0 | 0 |
| 1 | 1 | 0 | 0 |
| 0 | 0 | 1 | 0 |
| 1 | 0 | 1 | 0 |
| 0 | 1 | 1 | 0 |
| 1 | 1 | 1 | 0 |

O.2.2 4001 (Quad 2-In NOR)

This device contains four independent 2-input NOR gates.



Logic function:

$$O_1 = \overline{I_1 + I_2}$$

NOR gate truth table:

| I1 | I2 | O1 |
|----|----|----|
| 0 | 0 | 1 |
| 1 | 0 | 0 |
| 0 | 1 | 0 |
| 1 | 1 | 0 |

O.2.3 4002 (Dual 4-In NOR)



This device contains four independent 4-input NOR gates.

Logic function:

$$O_1 = \overline{I_1 + I_2 + I_3 + I_4}$$

$$O_2 = \overline{I_5 + I_6 + I_7 + I_8}$$

NOR gate truth table:

| I1 | I2 | I3 | I4 | O1 |
|----|----|----|----|----|
| 1 | X | X | X | 0 |
| X | 1 | X | X | 0 |
| X | X | 1 | X | 0 |
| X | X | X | 1 | 0 |
| 0 | 0 | 0 | 0 | 1 |

O.2.4 4007 (Dual Com Pair/Inv)

This device is a dual complementary pair and an inverter with access to each device. It has three n-channel and three p-channel enhancement mode MOS transistors.

O.2.5 4008 (4-bit Binary Full Adder)

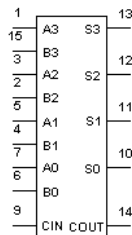

This device is capable of adding two 4-bit binary numbers together.

Logic function:

$$S = C_{IN} \oplus A \oplus B$$

$$C = AB + BC_{OUT} + AC_{OUT}$$

4-bit binary adder truth table:

| CIN | INPUTS | | | | | | | | OUTPUTS |
|-----|--------|----|----|----|----|----|----|----|------------------|
| | A1 | B1 | A2 | B2 | A3 | B3 | A4 | B4 | COU ^T |
| X | 1 | X | X | 1 | X | 1 | X | 1 | 1 |
| X | X | X | 1 | X | X | 1 | X | 1 | 1 |
| X | X | X | X | X | 1 | X | X | 1 | 1 |
| X | X | X | X | X | X | X | 1 | X | 1 |
| 1 | X | 1 | X | 1 | X | 1 | X | 1 | 1 |
| X | X | X | X | X | X | X | X | X | 0 |

O.2.6 4010 (Hex BUFFER)

This device contains six independent BUFFER gates.



Logic function:

$$Y = \bar{A}$$

BUFFER gate truth table:

| A | Y |
|---|---|
| 0 | 0 |
| 1 | 1 |

O.2.7 40106 (Hex INVERTER (Schmitt))



This device contains six independent INVERTER gates. Due to the Schmitt-trigger action, this device is ideal for circuits that are susceptible to unwanted small signals, such as noise.

Logic function:

$$Y = \bar{A}$$

INVERTER gate truth table:

| A | Y |
|---|---|
| 0 | 1 |
| 1 | 0 |

O.2.8 4011 (Quad 2-In NAND)

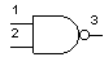

This device contains four independent 2-input NAND gates.

Logic function:

$$O_1 = \overline{I_1 I_2}$$

NAND gate truth table:

| I1 | I2 | O1 |
|----|----|----|
| 0 | 0 | 1 |
| 1 | 0 | 1 |
| 0 | 1 | 1 |
| 1 | 1 | 0 |

O.2.9 4012 (Dual 4-In NAND)



This device contains four independent 4-input NAND gates.

Logic function:

$$O_1 = \overline{I_1 + I_2 + I_3 + I_4}$$

NAND gate truth table:

| INPUTS | | | | OUTPUTS |
|--------|----|----|----|---------|
| I1 | I2 | I3 | I4 | O1 |
| 1 | 1 | 1 | 1 | 0 |
| 0 | X | X | X | 1 |
| X | 0 | X | X | 1 |
| X | X | 0 | X | 1 |
| X | X | X | 0 | 1 |

O.2.10 4013 (Dual D-type FF (+edge))

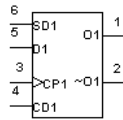

The 4013 device is a dual D-type flip-flop that features independent set direct (S_D), clear direct (C_D), clock inputs (CP) and outputs (O, \bar{O}).

D-type positive edge-triggered flip-flop truth table:

| \overline{SD} | \overline{CD} | CP | D | O | \bar{O} |
|-----------------|-----------------|----|---|---|-----------|
| 1 | 0 | X | X | 1 | 0 |
| 0 | 1 | X | X | 0 | 1 |
| 1 | 1 | X | X | 1 | 1 |
| 0 | 0 | . | 0 | 0 | 1 |
| 0 | 0 | . | 1 | 1 | 0 |

. = positive edge-triggered

O.2.11 4014 (8-bit Static Shift Reg)

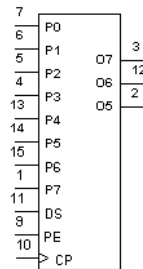

The 4014 device is a fully synchronous edge-triggered 8-bit static shift register with eight synchronous parallel inputs (P_0 to P_7), a synchronous serial data input (D_S), a synchronous parallel enable input (PE), a LOW to HIGH edge-triggered clock input (CP) and buffered parallel outputs from the last three stages (O_5 to O_7).

Following are two 8-bit static shift register truth tables.

Serial Operation:

| n | INPUTS | | | | | | | | | | | | OUTPUTS | | |
|----|--------|----|------|----|----|----|----|----|----|----|----|----|---------|----|-----------|
| | PE | DS | >CLK | P0 | P1 | P2 | P3 | P4 | P5 | P6 | P7 | O5 | O6 | O7 | |
| 1 | 0 | D1 | . | X | X | X | X | X | X | X | X | X | X | X | X |
| 2 | 0 | D2 | . | X | X | X | X | X | X | X | X | X | X | X | X |
| 3 | 0 | D3 | . | X | X | X | X | X | X | X | X | X | X | X | X |
| 4 | 0 | D4 | . | X | X | X | X | X | X | X | X | X | X | X | X |
| 5 | 0 | D5 | . | X | X | X | X | X | X | X | X | X | X | X | X |
| 6 | 0 | D6 | . | X | X | X | X | X | X | X | X | X | X | X | X |
| 7 | 0 | D7 | . | X | X | X | X | X | X | X | X | X | X | X | X |
| 9 | 0 | D8 | . | X | X | X | X | X | X | X | X | X | X | X | X |
| 10 | 0 | D9 | . | X | X | X | X | X | X | X | X | X | X | X | X |
| X | X | X | , | X | X | X | X | X | X | X | X | X | X | X | X |
| | | | | | | | | | | | | | | | no change |

Parallel Operation:

| PE | INPUTS | | | | | | | | | | | OUTPUTS | | | |
|----|--------|------|----|----|----|----|----|----|----|----|----|---------|----|----|-----------|
| | DS | >CLK | P0 | P1 | P2 | P3 | P4 | P5 | P6 | P7 | O5 | O6 | O7 | | |
| 1 | X | . | X | X | X | X | X | X | X | X | X | P5 | P6 | P7 | |
| 1 | X | , | X | X | X | X | X | X | X | X | X | | | | |
| | | | | | | | | | | | | | | | no change |

O.2.12 4015 (Dual 4-bit Static Shift Reg)

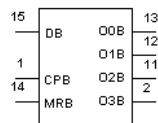

The 4015 device is a dual edge-triggered 4-bit static shift register (serial-to-parallel converter). Each shift register has a serial data input (D), a clock input (CP), four fully buffered parallel outputs (O₀ to O₃) and an overriding asynchronous master reset input (MR).

Shift register truth table:

| n | CP | D | MR | O0 | O1 | O2 | O3 |
|---|----|----|----|-----------|----|----|----|
| 1 | . | D1 | 0 | D1 | X | X | X |
| 2 | . | D2 | 0 | D2 | D1 | X | X |
| 3 | . | D3 | 0 | D3 | D2 | D1 | X |
| 4 | . | D4 | 0 | D4 | D3 | D2 | D1 |
| | , | X | 0 | no change | | | |
| | X | X | 1 | 0 | 0 | 0 | 0 |

- 1 = HIGH state (the more positive voltage)
- 0 = LOW state (the less positive voltage)
- X = state is immaterial
- .
- = positive-going transition
- ,
- = negative-going transition
- Dn = either HIGH or LOW
- n = number of clock pulse transitions

O.2.13 40160 (4-bit Dec Counter)

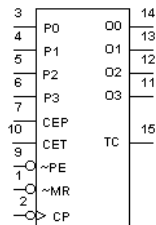

The 40160 device is a fully synchronous edge-triggered 4-bit decade counter with a clock input (CP), an overriding asynchronous master reset ($\overline{\text{MR}}$), four parallel data inputs (P0 to P3), three synchronous mode control inputs (parallel enable ($\overline{\text{PE}}$), count enable parallel (CEP) and count enable trickle (CET)), buffered outputs from all four bit positions (O0 to O3) and a terminal count output (TC).

O.2.14 40161 (4-bit Bin Counter)

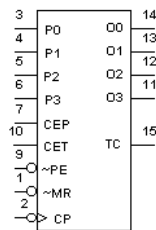

The 40161 device is a fully synchronous edge-triggered 4-bit binary counter with a clock input (CP), an overriding asynchronous master reset ($\overline{\text{MR}}$), four parallel data inputs (P0 to P3), three synchronous mode control inputs (parallel enable ($\overline{\text{PE}}$), count enable parallel (CEP) and count enable trickle (CET)), buffered outputs from all four bit positions (O0 to O3) and a terminal count output (TC).

O.2.15 40162 (4-bit Dec Counter)

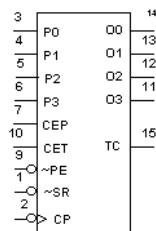

The 40162 device is a fully synchronous edge-triggered 4-bit decade counter with a clock input (CP), four synchronous parallel data inputs (P0 to P3), four synchronous mode control inputs (parallel enable ($\overline{\text{PE}}$), count enable parallel (CEP) and count enable trickle (CET)), and synchronous reset ($\overline{\text{SR}}$), buffered outputs from all four bit positions (O0 to O3) and a terminal count output (TC).

O.2.16 40163 (4-bit Bin Counter)

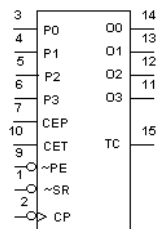

The 40163 device is a fully synchronous edge-triggered 4-bit binary counter with a clock input (CP), four synchronous parallel data inputs (P0 to P3), four synchronous mode control inputs (parallel enable ($\overline{\text{PE}}$), count enable parallel (CEP) and count enable trickle (CET)), and synchronous reset ($\overline{\text{SR}}$), buffered outputs from all four bit positions (O0 to O3) and a terminal count output (TC).

O.2.17 4017 (5-stage Johnson Counter)

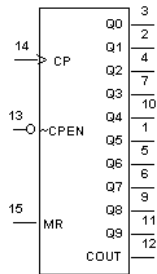

The 4017 device is a 5-stage Johnson decade counter with ten spike-free decoded active HIGH outputs (O_0 to O_9), an active LOW output from the most significant flip-flop ($\overline{O}_{5,9}$), active HIGH and active LOW clock inputs (CP_0 , \overline{CP}_1) and an overriding asynchronous master reset input (MR).

5-stage Johnson counter truth table:

| MR | CP0 | CP1 | OPERATION |
|----|-----|-----|----------------------------------------|
| 1 | X | X | $O_0 = O_5-9 = H$; O_1 to $O_9 = L$ |
| 0 | 1 | , | Counter advances |
| 0 | . | 0 | Counter advances |
| 0 | 0 | X | No change |
| 0 | X | 1 | No change |
| 0 | 1 | . | No change |
| 0 | , | 0 | No change |

1 = HIGH state (the more positive voltage)
 0 = LOW state (the less positive voltage)
 X = state is immaterial
 . = positive-going transition
 , = negative-going transition
 n = number of clock pulse transitions

O.2.18 40174 (Hex D-type Flip-flop)

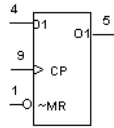

The 40174 device is a hex edge-triggered D-type flip-flop with six data inputs (D0 to D5), a clock input (CP), an overriding asynchronous master reset input ($\overline{\text{MR}}$), and six buffered outputs (O0 to O5).

Hex D-type flip-flop truth table:

| INPUTS | | | OUTPUT |
|--------|---|------------------------|-----------|
| CP | D | $\overline{\text{MR}}$ | O |
| | 1 | 1 | 1 |
| | 0 | 1 | 0 |
| | X | 1 | no change |
| X | X | 0 | 0 |

- 1 = HIGH state (the more positive voltage)
- 0 = LOW state (the less positive voltage)
- X = state is immaterial
- = positive-going transition
- ← = negative-going transition

O.2.19 40175 (Quad D-type Flip-flop)

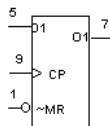

This device is a quadruple edge-triggered D-type flip-flop with four data inputs (D₀ to D₃), a clock input (CP), an overriding asynchronous master reset input ($\overline{\text{MR}}$), four buffered outputs (O₀ to O₃), and four complementary buffered outputs ($\overline{\text{O}}_0$ to $\overline{\text{O}}_3$).

Quadruple D-type flip-flop truth table:

| INPUTS | | | OUTPUTS | |
|--------|---|------------------------|-----------|-----------------------|
| CP | D | $\overline{\text{MR}}$ | O | $\overline{\text{O}}$ |
| | 1 | 1 | 1 | 0 |
| | 0 | 1 | 0 | 1 |
| | X | 1 | no change | no change |
| X | X | 0 | 0 | 1 |

1 = HIGH state (the more positive voltage)

0 = LOW state (the less positive voltage)

X = state is immaterial

= positive-going transition

= negative-going transition

O.2.20 4018 (5-stage Johnson Counter)

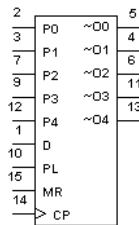

The 4018 device is a 5-stage Johnson counter with a clock input (CP), a data input (D), an asynchronous parallel load input (PL), five parallel inputs (P0 to P4), five active LOW buffered outputs ($\overline{\text{O0}}$ to $\overline{\text{O4}}$), and an overriding asynchronous master reset input ($\overline{\text{MR}}$).

5-stage Johnson counter truth table:

| Counter mode; divide by | Connect D input to | Remarks |
|-------------------------|---------------------------------------------------|------------------------------------------------|
| 10 | $\overline{\text{O4}}$ | |
| 8 | $\overline{\text{O3}}$ | |
| 6 | $\overline{\text{O2}}$ | no external components needed |
| 4 | $\overline{\text{O1}}$ | |
| 2 | $\overline{\text{O0}}$ | |
| 9 | $\overline{\text{O3}} \cdot \overline{\text{O4}}$ | AND gate needed; counter skips all HIGH states |
| 7 | $\overline{\text{O2}} \cdot \overline{\text{O3}}$ | |
| 5 | $\overline{\text{O1}} \cdot \overline{\text{O2}}$ | |
| 3 | $\overline{\text{O0}} \cdot \overline{\text{O1}}$ | |

O.2.21 4019 (Quad 2-In MUX)

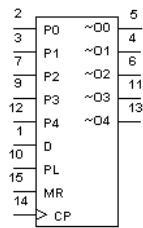

The 4019 device provides four multiplexing circuits with common select inputs (S_A , S_B); each circuit contains two inputs (A_n , B_n) and one output (O_n).

Multiplexer truth table:

| SELECT | | INPUTS | | OUTPUTS |
|--------|----|--------|----|---------|
| Sa | Sb | A0 | B0 | O0 |
| 0 | 0 | X | X | 0 |
| 1 | 0 | 0 | X | 0 |
| 1 | 0 | 1 | X | 1 |
| 0 | 1 | X | 0 | 0 |
| 0 | 1 | X | 1 | 1 |
| 1 | 1 | 1 | X | 1 |
| 1 | 1 | X | 1 | 1 |
| 1 | 1 | 0 | 0 | 0 |

O.2.22 40192 (4-bit Dec Counter)

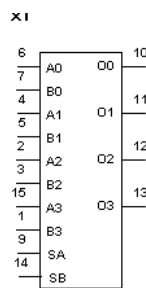

The 40192 device is a 4-bit synchronous up/down decade counter with a count-up clock input (CPU), a count-down clock input (CPD), an asynchronous parallel load input (\overline{PL}), four parallel data inputs (P0 to P3), an asynchronous master reset input (MR), four counter outputs (O0 to O3), an active LOW terminal count-up (carry) output (\overline{TCU}) and an active LOW terminal count-down (borrow) output (\overline{TCD}).

O.2.23 40193 (4-bit Bin Counter)

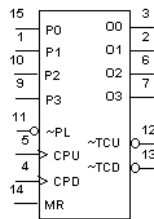

The 40193 device is a 4-bit synchronous up/down binary counter with a count-up clock input (CPU), a count-down clock input (CPD), an asynchronous parallel load input (\overline{PL}), four parallel data inputs (P0 to P3), an asynchronous master reset input (MR), four counter outputs (O0 to O3), an active LOW terminal count-up (carry) output (\overline{TCU}) and an active LOW terminal count-down (borrow) output (\overline{TCD}).

O.2.24 40194 (4-bit Shift Register)

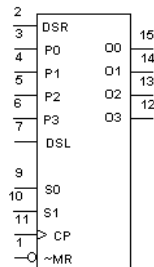

The 40194 device is a 4-bit bidirectional shift register with two mode control inputs (S0 and S1), a clock input (CP), a serial data shift left input (DSL), a serial data shift right input (DSR), four parallel data inputs (P0 to P3), an overriding asynchronous master reset input (\overline{MR}), and four buffered parallel outputs (O0 to O3).

O.2.25 40195 (4-bit Shift Register)

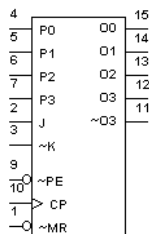

The 40195 device is a fully synchronous edge-triggered 4-bit shift register with a clock input (CP), four synchronous parallel data inputs (P0 to P3), two synchronous serial data inputs (J, \overline{K}), a synchronous parallel enable input (\overline{PE}), buffered parallel outputs from all 4-bit positions (O0 to O3), a buffered inverted output from the last bit position ($\overline{O3}$) and an overriding asynchronous master reset input (\overline{MR}).

O.2.26 4020 (14-stage Bin Counter)

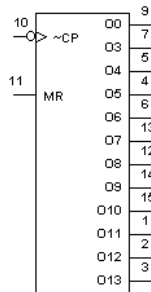

The 4020 device is a 14-stage binary ripple counter with a clock input (\overline{CP}), an overriding asynchronous master reset input (MR) and twelve fully buffered outputs (O_0, O_3 to O_{13}).

O.2.27 4021 (8-bit Static Shift Register)

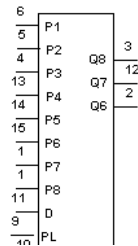

The 4021 device is an 8-bit static shift register (parallel-to-serial converter) with a synchronous serial data input (D_S), a clock input (CP), an asynchronous active HIGH parallel load input (PL), eight asynchronous parallel data inputs (P_0 to P_7) and buffered parallel outputs from the last three stages (O_5 to O_7).

O.2.28 4023 (Tri 3-In NAND)



This device contains three independent 3-input NAND gates.

Logic function:

$$O = \overline{I_1 + I_2 + I_3}$$

NAND gate truth table:

| I ₁ | I ₂ | I ₃ | O ₁ |
|----------------|----------------|----------------|----------------|
| 0 | 0 | 0 | 1 |
| 1 | 0 | 0 | 1 |
| 0 | 1 | 0 | 1 |
| 1 | 1 | 0 | 1 |
| 0 | 0 | 1 | 1 |
| 1 | 0 | 1 | 1 |
| 0 | 1 | 1 | 1 |
| 1 | 1 | 1 | 0 |

O.2.29 4024 (7-stage Binary Counter)

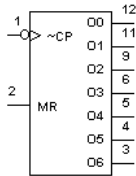

The 4024 is a 7-stage binary ripple counter. A high on MR (Master Reset) forces all counter stages and outputs low.

The 4024 counts from 0 to 15 in binary on every negative (high to low) transition of the clock pulse

7-stage counter truth table:

| INPUTS | | OUTPUTS | | | | | | |
|--------|----|---------|----|----|-------|----|----|----|
| MR | CP | Qg | Qf | Qe | Qd | Qc | Qb | Qa |
| 1 | X | 0 | 0 | 0 | 0 | 0 | 0 | 0 |
| 0 | , | | | | Count | | | |
| 0 | , | | | | Count | | | |

O.2.30 40240 (Octal Inv Buffer)

The 40240 device is an octal inverting buffer with 3-state outputs.

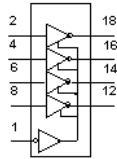

O.2.31 40244 (Octal Non-inv Buffer)

The 40244 device is an octal non-inverting buffer with 3-state outputs.

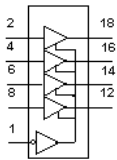

O.2.32 40245 (Octal Bus Transceiver)

The 40245 device, an octal bus transmitter/receiver with 3-state outputs, is designed for 8-line asynchronous, 2-way data communication between data buses.

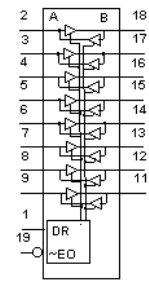

O.2.33 4025 (Tri 3-In NOR)



This device contains three independent 3-input NOR gates.

Logic function:

$$O = \overline{I_1 + I_2 + I_3}$$

NOR gate truth table:

| I_1 | I_2 | I_3 | O_1 |
|-------|-------|-------|-------|
| 0 | 0 | 0 | 1 |
| 0 | 1 | 0 | 0 |
| 1 | 0 | 0 | 0 |
| 1 | 1 | 0 | 0 |
| 0 | 0 | 1 | 0 |
| 1 | 0 | 1 | 0 |
| 0 | 1 | 1 | 0 |
| 1 | 1 | 1 | 0 |

O.2.34 4027 (Dual JK FF (+edge, pre, clr))

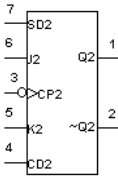

This device contains two independent JK flip-flops. They have separate pre-set and clear inputs.

JK flip-flop truth table:

| SD | CD | CP | J | K | On | $\overline{\text{On}}$ |
|----|----|----|---|---|--------|------------------------|
| 1 | 0 | X | X | X | 1 | 0 |
| 0 | 1 | X | X | X | 0 | 1 |
| 1 | 1 | X | X | X | 1 | 1 |
| 0 | 0 | . | 0 | 0 | Hold | |
| 0 | 0 | . | 1 | 0 | 1 | 0 |
| 0 | 0 | . | 0 | 1 | 0 | 1 |
| 0 | 0 | . | 1 | 1 | Toggle | |

. = triggers on POSITIVE pulse

O.2.35 4028 (1-of-10 Dec)

The 4028 device is a 4-bit BCD to 1-of-10 active HIGH decoder.

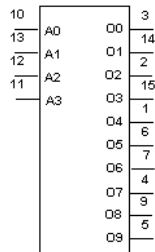

1-of-10 decoder truth table:

| BCD INPUTS | | | | DECIMAL OUTPUTS | | | | | | | | | |
|-----------------------|----|----|----|-----------------|----|----|----|----|----|----|----|----|----|
| A3 | A2 | A1 | A0 | O0 | O1 | O2 | O3 | O4 | O5 | O6 | O7 | O8 | O9 |
| 0 | 0 | 0 | 0 | 1 | 0 | 0 | 0 | 0 | 0 | 0 | 0 | 0 | 0 |
| 0 | 0 | 0 | 1 | 0 | 1 | 0 | 0 | 0 | 0 | 0 | 0 | 0 | 0 |
| 0 | 0 | 1 | 0 | 0 | 0 | 1 | 0 | 0 | 0 | 0 | 0 | 0 | 0 |
| 0 | 0 | 1 | 1 | 0 | 0 | 0 | 1 | 0 | 0 | 0 | 0 | 0 | 0 |
| 0 | 1 | 0 | 0 | 0 | 0 | 0 | 0 | 1 | 0 | 0 | 0 | 0 | 0 |
| 0 | 1 | 0 | 1 | 0 | 0 | 0 | 0 | 0 | 1 | 0 | 0 | 1 | 0 |
| 0 | 1 | 1 | 0 | 0 | 0 | 0 | 0 | 0 | 0 | 1 | 0 | 0 | 0 |
| 0 | 1 | 1 | 1 | 0 | 0 | 0 | 0 | 0 | 0 | 0 | 1 | 0 | 0 |
| 1 | 0 | 0 | 0 | 0 | 0 | 0 | 0 | 0 | 0 | 0 | 0 | 1 | 0 |
| 1 | 0 | 0 | 1 | 0 | 0 | 0 | 0 | 0 | 0 | 0 | 0 | 0 | 1 |
| *Extraordinary states | | | | | | | | | | | | | |
| 1 | 0 | 1 | 0 | 0 | 0 | 0 | 0 | 0 | 0 | 0 | 0 | 0 | 0 |
| 1 | 0 | 1 | 1 | 0 | 0 | 0 | 0 | 0 | 0 | 0 | 0 | 0 | 0 |
| 1 | 1 | 0 | 0 | 0 | 0 | 0 | 0 | 0 | 0 | 0 | 0 | 0 | 0 |
| 1 | 1 | 0 | 1 | 0 | 0 | 0 | 0 | 0 | 0 | 0 | 0 | 0 | 0 |
| 1 | 1 | 1 | 0 | 0 | 0 | 0 | 0 | 0 | 0 | 0 | 0 | 0 | 0 |
| 1 | 1 | 1 | 1 | 0 | 0 | 0 | 0 | 0 | 0 | 0 | 0 | 0 | 0 |
| 1 | 1 | 1 | 1 | 1 | 0 | 0 | 0 | 0 | 0 | 0 | 0 | 0 | 0 |

O.2.36 4029 (4-bit Bin/BCD Dec Counter)



The 4029 is a synchronous edge-triggered up/down 4-bit binary/BCD decade counter with a clock input (CP), an active LOW count enable input ($\overline{\text{CE}}$), an up/down control input (UP/DN), a binary/decade control input (BIN/ $\overline{\text{DEC}}$), an overriding asynchronous active HIGH parallel load input (PL), four parallel data inputs (P0 to P3), four parallel buffered outputs (O0 to O3) and an active LOW terminal count output ($\overline{\text{TC}}$).

4-bit binary/BCD decade counter truth table:

| PL | BIN/ $\overline{\text{DEC}}$ | UP/DN | $\overline{\text{CE}}$ | CP | mode |
|----|------------------------------|-------|------------------------|----|-------------------------|
| 1 | X | X | X | X | parallel load (Pn → On) |
| 0 | X | X | 1 | X | no change |
| 0 | 0 | 0 | 0 | | count-down, decade |
| 0 | 0 | 1 | 0 | | count-up, decade |
| 0 | 1 | 0 | 0 | | count-down, binary |
| 0 | 1 | 1 | 0 | | count-up, binary |

1 = HIGH state (the more positive voltage)

0 = LOW state (the less positive voltage)

X = state is immaterial

= positive-going clock pulse edge

O.2.37 4030 (Quad 2-In XOR)

This device contains four independent 2-input EXCLUSIVE-OR gates.



Logic function:

$$O = I_1 \oplus I_2$$

EXCLUSIVE-OR gate truth table:

| I1 | I2 | O1 |
|----|----|----|
| 0 | 0 | 0 |
| 0 | 1 | 1 |
| 1 | 0 | 1 |
| 1 | 1 | 0 |

O.2.38 4032 (Triple Serial Adder)

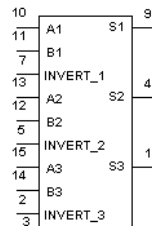

The 4032 triple serial adder has the clock and carry reset inputs common to all three adders. The carry is added on the positive-going clock transition for this device.

O.2.39 4035 (4-bit Shift Register)

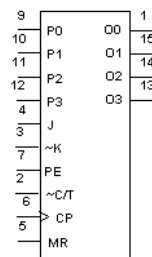

The 4035 device is a fully synchronous edge-triggered 4-bit shift register with a clock input (CP), four synchronous parallel data inputs (P0 to P3), two synchronous serial data inputs (J, \bar{K}), a synchronous parallel enable input (PE), buffered parallel outputs from all 4-bit positions (O0 to O3), a true/complement input (T/\bar{C}) and an overriding asynchronous master reset input (MR).

Following are two shift register truth tables.

Serial operation first stage:

| CP | INPUTS | | | OUTPUT | MODE OF OPERATION |
|----|--------|-----------|----|-------------|-------------------|
| | J | \bar{K} | MR | O_0+1 | |
| | 1 | 1 | 0 | 1 | D flip-flop |
| | 0 | 0 | 0 | 0 | D flip-flop |
| | 1 | 0 | 0 | \bar{O}_0 | toggle |
| | 0 | 1 | 0 | O_0 | no change |
| X | X | X | 1 | 0 | reset |

Parallel operation:

| CP | INPUTS | | | | OUTPUTS | | | |
|----|--------|----|----|----|---------|----|----|----|
| | P0 | P1 | P2 | P3 | O0 | O1 | O2 | O3 |
| | 0 | 0 | 0 | 0 | 0 | 0 | 0 | 0 |
| | 1 | 1 | 1 | 1 | 1 | 1 | 1 | 1 |

= positive-going transition

1 = HIGH state (the more positive voltage)

0 = LOW state (the less positive voltage)

X = state is immaterial

O.2.40 40373 (Octal Trans Latch)

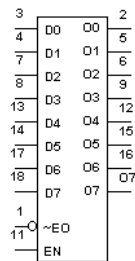

The 40373 device is an 8-bit transparent latch with 3-state buffered outputs.

O.2.41 40374 (Octal D-type Flip-flop)

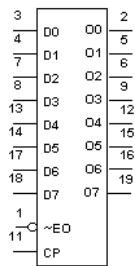

The 40374 device is an octal D-type flip-flop with 3-state buffered outputs with a common clock input (CP). It is used primarily as an 8-bit positive edge-triggered storage register for interfacing with a 3-state bus.

O.2.42 4038 (Triple Serial Adder)

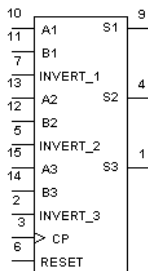

The 4038 triple serial adder has the clock and carry reset inputs common to all three adders. The carry is added on the negative-going clock transition for this device.

O.2.43 4040 (12-stage Binary Counter)

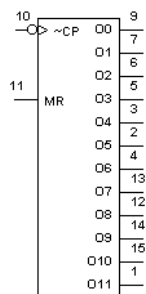

The 4040 device is a 12-stage binary ripple counter with a clock input (CP), an overriding asynchronous master reset input (MR) and twelve fully buffered outputs (O₀ to O₁₁).

12-stage binary counter truth table:

| $\overline{\text{CP}}$ | MR | O0-O11 |
|------------------------|----|--------|
| , | 0 | Count |
| , | 1 | 0 |

O.2.44 4041 (Quad True/Complement BUFFER)



This device provides both inverted and non-inverted buffered outputs for each input.

Logic function:

$$\begin{aligned}\bar{O} &= \bar{I} \\ O &= I\end{aligned}$$

Buffer gate truth table:

| I | O | \bar{O} |
|---|---|-----------|
| 0 | 0 | 1 |
| 1 | 1 | 0 |

O.2.45 4042 (Quad D-latch)

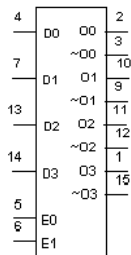

This device contains four independent D-latches.

D-latch truth table:

| $\bar{E}n$ | $\bar{E}l$ | On |
|------------|------------|---------|
| 0 | 0 | Dn |
| 0 | 1 | Latched |
| 1 | 0 | Latched |
| 1 | 1 | Dn |

O.2.46 4043 (Quad RS latch w/3-state Out)

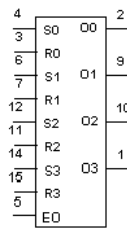

This device contains four independent RS-latches with 3-state outputs.

RS-latch truth table:

| EO | Sn | Rn | On |
|----|----|----|---------|
| 0 | X | X | Z |
| 1 | 0 | 1 | 0 |
| 1 | 1 | X | 1 |
| 1 | 0 | 0 | Latched |

O.2.47 4044 (Quad RS latch w/3-state Out)

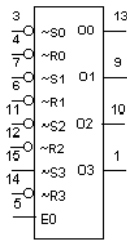

This device contains four independent RS-latches with 3-state outputs.

RS-latch truth table:

| EO | $\overline{S_n}$ | $\overline{R_n}$ | On |
|----|------------------|------------------|---------|
| 0 | X | X | Z |
| 1 | 0 | 1 | 1 |
| 1 | X | 0 | 0 |
| 1 | 1 | 1 | Latched |

O.2.48 4049 (Hex INVERTER)



This device contains six independent INVERTER gates.

Logic function:

$$O = \overline{I}$$

INVERTER gate truth table:

| I1 | O1 |
|----|----|
| 1 | 0 |
| 0 | 1 |

O.2.49 4050 (Hex BUFFER)



This device contains six independent BUFFER/non-inverting gates.

Logic function:

$$Y = \bar{A}$$

BUFFER gate truth table:

| A | Y |
|---|---|
| 0 | 0 |
| 1 | 1 |

O.2.50 4066 (Quad Analog Switches)

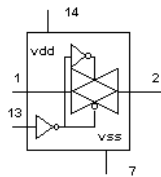

The 4066 device has four independent bilateral analogue switches (transmission gates). Each switch has two input/output terminals (Y/Z) and an active HIGH enable input (E).

When the C input is high, the input/outputs A and B, will pass either digital or analog signals in either direction.

Analog switch truth table:

| C | A | B |
|---|-----|---|
| 0 | | Z |
| 1 | <-> | |

O.2.51 4068 (8-In NAND)

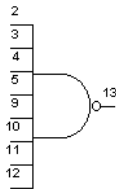

Logic function:

$$O_1 = \overline{I_0 I_1 I_2 I_3 I_4 I_5 I_6 I_7}$$

NAND gate truth table:

| INPUTS I0 THROUGH I7 | O1 |
|----------------------|----|
| All inputs 1 | 0 |
| One or more inputs | 1 |

O.2.52 4069 (Hex INVERTER)

This device contains six independent INVERTER gates.



Logic function:

$$A = \bar{Y}$$

INVERTER gate truth table:

| A | Y |
|---|---|
| 0 | 1 |
| 1 | 0 |

O.2.53 4070 (Quad 2-In XOR)

This device contains four independent 2-input EXCLUSIVE-OR gates.



Logic function:

$$Y = \bar{A} \oplus \bar{B}$$

EXCLUSIVE-OR gate truth table:

| A | B | Y |
|---|---|---|
| 0 | 0 | 0 |
| 0 | 1 | 1 |
| 1 | 0 | 1 |
| 1 | 1 | 0 |

O.2.54 4071 (Quad 2-In OR)

This device contains four independent 2-input OR gates.



Logic function:

$$Y = \overline{A+B}$$

OR gate truth table:

| A | B | Y |
|---|---|---|
| 0 | 0 | 0 |
| 1 | 0 | 1 |
| 0 | 1 | 1 |
| 1 | 1 | 1 |

O.2.55 4072 (Dual 4-In OR)

The 4072 device provides the positive dual 4-input OR function.



Logic function:

$$Y = \overline{\overline{A+B+C+D}}$$

4-input OR gate truth table:

| INPUTS | | | | OUTPUT |
|--------|---|---|---|--------|
| A | B | C | D | Y |
| 0 | 0 | 0 | 0 | 0 |
| 0 | 0 | 0 | 1 | 1 |
| 0 | 0 | 1 | 0 | 1 |
| 0 | 0 | 1 | 1 | 1 |
| 0 | 1 | 0 | 0 | 1 |
| 0 | 1 | 0 | 1 | 1 |
| 0 | 1 | 1 | 0 | 1 |
| 0 | 1 | 1 | 1 | 1 |
| 1 | 0 | 0 | 0 | 1 |
| 1 | 0 | 0 | 1 | 1 |
| 1 | 0 | 1 | 0 | 1 |
| 1 | 0 | 1 | 1 | 1 |
| 1 | 1 | 0 | 0 | 1 |
| 1 | 1 | 0 | 1 | 1 |
| 1 | 1 | 1 | 0 | 1 |
| 1 | 1 | 1 | 1 | 1 |

O.2.56 4073 (Tri 3-In AND)

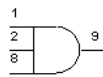

This device contains three independent 3-input AND gates.

Logic function:

$$Y = \overline{ABC}$$

AND gate truth table:

| A | B | C | Y |
|---|---|---|---|
| 0 | 0 | 0 | 0 |
| 1 | 0 | 0 | 0 |
| 0 | 1 | 0 | 0 |
| 1 | 1 | 0 | 0 |
| 0 | 0 | 1 | 0 |
| 1 | 0 | 1 | 0 |
| 0 | 1 | 1 | 0 |
| 1 | 1 | 1 | 1 |

O.2.57 4075 (Tri 3-In OR)



This device contains three independent 3-input OR gates.

Logic function:

$$Y = \overline{\overline{A+B+C}}$$

OR gate truth table:

| A | B | C | Y |
|---|---|---|---|
| 0 | 0 | 0 | 0 |
| 0 | 0 | 1 | 1 |
| 0 | 1 | 0 | 1 |
| 0 | 1 | 1 | 1 |
| 1 | 0 | 0 | 1 |
| 1 | 0 | 1 | 1 |
| 1 | 1 | 0 | 1 |
| 1 | 1 | 1 | 1 |

O.2.58 4076 (Quad D-type Reg w/3-state Out)

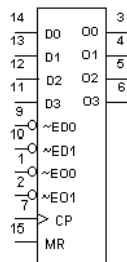

The 4076 device is a quadruple edge-triggered D-type flip-flop with four data inputs (D_0 to D_3), two active LOW data enable inputs (\overline{ED}_0 and \overline{ED}_1), a common clock input (CP), four 3-state outputs (O_0 to O_3), two active LOW output enable inputs (\overline{EO}_0 and \overline{EO}_1), and an overriding asynchronous master reset input (MR).

D-type register truth table:

| INPUTS | | | | | OUTPUTS |
|--------|----|-----|-----|----|-----------|
| MR | CP | ED0 | ED1 | Dn | On |
| 1 | X | X | X | X | 0 |
| 0 | . | 1 | X | X | NO CHANGE |
| 0 | . | X | 1 | X | NO CHANGE |
| 0 | . | 0 | 0 | 1 | 1 |
| 0 | . | 0 | 0 | 0 | 0 |
| 0 | , | X | X | X | NO CHANGE |

O.2.59 4077 (Quad 2-In XNOR)

This device contains four independent 2-input EXCLUSIVE-NOR gates.



Logic function:

$$O = \bar{A} \oplus \bar{B}$$

EXCLUSIVE-NOR gate truth table:

| An | Bn | On |
|----|----|----|
| 0 | 0 | 1 |
| 0 | 1 | 0 |
| 1 | 0 | 0 |
| 1 | 1 | 1 |

O.2.60 4078 (8-In NOR)

Logic function:

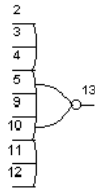

$$O = \overline{I_0 + I_1 + I_2 + I_3 + I_4 + I_5 + I_6 + I_7}$$

8-input NOR gate simplified truth table:

If one or more inputs are high, the output is low.

| INPUTS | | | | | | | | OUTPUT |
|--------|----|----|----|----|----|----|----|--------|
| I0 | I1 | I2 | I3 | I4 | I5 | I6 | I7 | O1 |
| 0 | 0 | 0 | 0 | 0 | 0 | 0 | 0 | 1 |
| 1 | X | X | X | X | X | X | X | 0 |
| X | 1 | X | X | X | X | X | X | 0 |
| X | X | 1 | X | X | X | X | X | 0 |
| X | X | X | 1 | X | X | X | X | 0 |
| X | X | X | X | 1 | X | X | X | 0 |
| X | X | X | X | X | 1 | X | X | 0 |
| X | X | X | X | X | X | 1 | X | 0 |
| X | X | X | X | X | X | X | 1 | 0 |

O.2.61 4081 (Quad 2-In AND)

This device contains four independent 2-input AND gates.

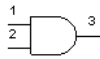

Logic function:

$$Y = AB$$

AND gate truth table:

| A | B | Y |
|---|---|---|
| 0 | 0 | 0 |
| 1 | 0 | 0 |
| 0 | 1 | 0 |
| 1 | 1 | 1 |

O.2.62 4082 (Dual 4-In AND)

This device contains two independent 4-input AND gates.



All 4-inputs on each 4-input gate must be high to obtain a high at the output.

Logic function:

$$Y = ABCD$$

AND gate truth table:

| A | B | C | D | Y |
|---|---|---|---|---|
| 0 | 0 | 0 | 0 | 0 |
| 0 | 0 | 0 | 1 | 0 |
| 0 | 0 | 1 | 0 | 0 |
| 0 | 0 | 1 | 1 | 0 |
| 0 | 1 | 0 | 0 | 0 |
| 0 | 1 | 0 | 1 | 0 |
| 0 | 1 | 1 | 0 | 0 |
| 0 | 1 | 1 | 1 | 0 |
| 1 | 0 | 0 | 0 | 0 |
| 1 | 0 | 0 | 1 | 0 |
| 1 | 0 | 1 | 0 | 0 |
| 1 | 0 | 1 | 1 | 0 |
| 1 | 1 | 0 | 0 | 0 |
| 1 | 1 | 0 | 1 | 0 |
| 1 | 1 | 1 | 0 | 0 |
| 1 | 1 | 1 | 1 | 1 |

O.2.63 4085 (Dual 2-Wide 2-In AND-OR-INVERTER)

This device contains a combination of gates (AND, OR and INVERTER).

Logic function:

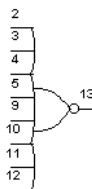

$$O_A = \overline{A_0 \bullet A_1 + A_2 \bullet A_3 + A_4}$$

$$O_B = \overline{B_0 \bullet B_1 + B_2 \bullet B_3 + B_4}$$

Inverter gate truth table:

| INPUTS | | | | | OUTPUT |
|--------|----|----|----|----|--------|
| A0 | A1 | A2 | A3 | A4 | OA |
| 0 | 0 | 0 | 0 | 0 | 1 |
| 0 | 0 | 0 | 0 | 1 | 0 |
| 0 | 0 | 0 | 1 | 0 | 1 |
| 0 | 0 | 0 | 1 | 1 | 0 |
| 0 | 0 | 1 | 0 | 0 | 1 |
| 0 | 0 | 1 | 0 | 1 | 0 |
| 0 | 0 | 1 | 1 | 0 | 1 |
| 0 | 0 | 1 | 1 | 1 | 0 |
| 0 | 1 | 0 | 0 | 0 | 0 |
| 0 | 1 | 0 | 0 | 1 | 0 |
| 0 | 1 | 0 | 1 | 0 | 1 |
| 0 | 1 | 0 | 1 | 1 | 0 |
| 0 | 1 | 1 | 0 | 0 | 1 |
| 0 | 1 | 1 | 0 | 1 | 0 |
| 0 | 1 | 1 | 1 | 0 | 1 |
| 0 | 1 | 1 | 1 | 1 | 0 |
| 1 | 0 | 0 | 0 | 0 | 0 |
| 1 | 0 | 0 | 0 | 1 | L |
| 1 | 0 | 0 | 1 | 0 | 1 |
| 1 | 0 | 0 | 1 | 1 | 0 |
| 1 | 0 | 1 | 0 | 0 | 1 |
| 1 | 0 | 1 | 0 | 1 | 0 |
| 1 | 0 | 1 | 1 | 0 | 1 |
| 1 | 0 | 1 | 1 | 1 | 0 |
| 1 | 1 | 0 | 0 | 0 | 0 |
| 1 | 1 | 0 | 0 | 1 | 0 |
| 1 | 1 | 0 | 1 | 0 | 0 |
| 1 | 1 | 0 | 1 | 1 | 0 |
| 1 | 1 | 1 | 0 | 0 | 0 |
| 1 | 1 | 1 | 0 | 1 | 0 |
| 1 | 1 | 1 | 1 | 0 | 0 |
| 1 | 1 | 1 | 1 | 1 | 0 |

O.2.64 4086 (4-Wide 2-In AND-OR-INVERTER)

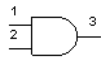

This device contains a combination of gates (AND, OR and INVERTER).

Logic function:

$$O = \overline{I_0 I_1 + I_2 I_3 + I_4 I_5 + I_6 I_7 + I_8 + I_9}$$

Inverter gate truth table:

| INPUTS | | | | | | | | | OUTPUT | |
|---------------------------------|----|----|----|----|----|----|----|----|--------|---|
| I0 | I1 | I2 | I3 | I4 | I5 | I6 | I7 | I8 | ~I9 | O |
| X | X | X | X | X | X | X | X | 1 | X | 0 |
| X | X | X | X | X | X | X | X | X | 0 | 0 |
| 1 | 1 | X | X | X | X | X | X | X | X | 0 |
| X | X | 1 | 1 | X | X | X | X | X | X | 0 |
| X | X | X | X | 1 | 1 | X | X | X | X | 0 |
| X | X | X | X | X | X | 1 | 1 | X | X | 0 |
| ANY OTHER COMBINATION OF INPUTS | | | | | | | | | | 1 |

O.2.65 4093 (Quad 2-In NAND (Schmitt))

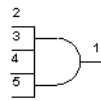

This device contains four independent 2-input NAND gates. Due to the Schmitt-trigger action, this device is ideal for circuits that are susceptible to unwanted small signals, such as noise.

Logic function:

$$O = \overline{A1B2}$$

NAND gate truth table:

| A | B | Y |
|---|---|---|
| 0 | 0 | 1 |
| 0 | 1 | 1 |
| 1 | 0 | 1 |
| 1 | 1 | 0 |

O.2.66 4094 (8-stage Serial Shift Register)

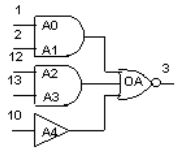

The 4094 device is an 8-stage serial shift register having a storage latch associated with each stage for strobing data from the serial input to parallel buffered 3-state outputs O0 to O7.

Shift register truth table:

| INPUTS | | | | PARALLEL OUTPUTS | | SERIAL OUTPUTS | |
|--------|----|-----|---|------------------|------------------|------------------|------------------|
| CP | EO | STR | D | O ₀ | O _n | O _s | \overline{O}_s |
| 0 | X | X | X | Z | Z | \overline{O}_6 | nc |
| 0 | X | X | X | Z | Z | nc | O ₇ |
| 1 | 0 | X | X | nc | nc | \overline{O}_6 | nc |
| 1 | 1 | 0 | X | 0 | O _{n-1} | \overline{O}_6 | nc |
| 1 | 1 | 1 | X | 1 | O _{n-1} | \overline{O}_6 | nc |
| 1 | 1 | 1 | X | nc | nc | nc | O ₇ |

1 = HIGH state (the more positive voltage)

0 = LOW state (the less positive voltage)

X = state is immaterial

= positive-going transition

= negative-going transition

Z = high impedance off state

nc = no change

\overline{O}_6 = the information in the seventh shift register stage

O.2.67 4099 (8-bit Latch)

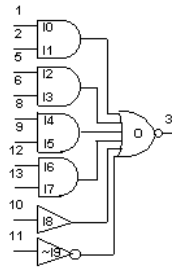

The 4099 device is an 8-bit addressable latch. The input for this device is a unidirectional write only port.

O.2.68 4502 (Strobed hex INVERTER)

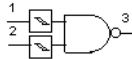

This device contains six independent INVERTER gates.

INVERTER gate truth table:

| Dn | \bar{E} | \overline{EO} | On |
|----|-----------|-----------------|----|
| 0 | 0 | 0 | 1 |
| 1 | 0 | 0 | 0 |
| X | 1 | 0 | 0 |
| X | X | 1 | Z |

O.2.69 4503 (Tri-state hex BUFFER w/Strobe)

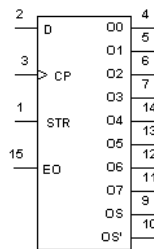

Four of these six non-inverting buffers (I1 through I4) are enabled by a high on EN1 and the last two (I5 and I6) are enabled by a high on EN2.

Buffer gate truth table:

| I | EN | O |
|---|----|---|
| 0 | 0 | 0 |
| 1 | 0 | 1 |
| X | 1 | Z |

Z = High impedance

X = Don't care

O.2.70 4508 (Dual 4-bit latch)

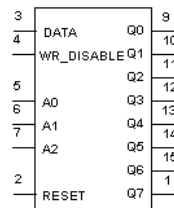

This device contains two independent 4-bit latches.

4-bit latch truth table:

| INPUTS | | | | OUTPUTS |
|--------|----|----|----|---------|
| MR | ST | EO | Dn | On |
| 0 | 1 | 0 | 1 | 1 |
| 0 | 1 | 0 | 0 | 0 |
| 0 | 0 | 0 | X | LATCHED |
| 1 | X | 0 | X | 0 |
| X | X | 1 | X | Z |

O.2.71 4510 (BCD up/down Counter)

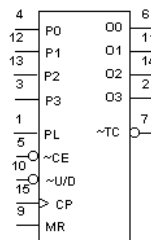

BCD up/down counter truth table:

| MR | \overline{PL} | UP/DN | CE | CP | MODE |
|----|-----------------|-------|----|----|---------------|
| 0 | 1 | X | X | X | PARALLEL LOAD |
| 0 | 0 | X | 1 | X | NO CHANGE |
| 0 | 0 | 0 | 0 | . | COUNT DOWN |
| 0 | 0 | 1 | 0 | . | COUNT UP |
| 1 | X | X | X | X | RESET |

O.2.72 4511(BCD-to-seven segment latch/Dec)

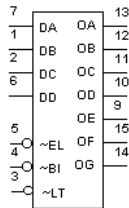

The 4511 BCD (Binary-Coded Decimal)-to-seven-segment latch decoder translates a 4-bit BCD input into hexadecimal, and outputs high on the output pins corresponding to the hexadecimal representation of the BCD input. There are provisions for lamp testing and for blanking the outputs

| DISPLAY | INPUTS | | | | | | | OUTPUTS | | | | | | |
|---------|------------------------|------------------------|------------------------|---|---|---|---|---------|---|---|---|---|---|---|
| | $\overline{\text{EL}}$ | $\overline{\text{BI}}$ | $\overline{\text{LT}}$ | D | C | B | A | a | b | c | d | e | f | g |
| 8 | X | X | 0 | 0 | 0 | 0 | 0 | 1 | 1 | 1 | 1 | 1 | 1 | 0 |
| | X | 0 | 1 | 0 | 0 | 0 | 0 | 1 | 1 | 1 | 1 | 1 | 1 | 0 |
| 0 | 0 | 1 | 1 | 0 | 0 | 0 | 0 | 1 | 1 | 1 | 1 | 1 | 1 | 0 |
| 1 | 0 | 1 | 1 | 0 | 0 | 0 | 1 | 0 | 1 | 1 | 0 | 0 | 0 | 0 |
| 2 | 0 | 1 | 1 | 0 | 0 | 1 | 0 | 1 | 1 | 0 | 1 | 1 | 0 | 1 |
| 3 | 0 | 1 | 1 | 0 | 0 | 1 | 1 | 1 | 1 | 1 | 1 | 0 | 0 | 1 |
| 4 | 0 | 1 | 1 | 0 | 1 | 0 | 0 | 0 | 1 | 1 | 0 | 0 | 1 | 1 |
| 5 | 0 | 1 | 1 | 0 | 1 | 0 | 1 | 1 | 0 | 1 | 1 | 0 | 1 | 1 |
| 6 | 0 | 1 | 1 | 0 | 1 | 1 | 0 | 0 | 0 | 1 | 1 | 1 | 1 | 0 |
| 7 | 0 | 1 | 1 | 0 | 1 | 1 | 1 | 1 | 1 | 1 | 0 | 0 | 0 | 0 |
| 8 | 0 | 1 | 1 | 1 | 0 | 0 | 0 | 1 | 1 | 1 | 1 | 1 | 1 | 1 |
| 9 | 0 | 1 | 1 | 1 | 0 | 0 | 1 | 1 | 1 | 1 | 0 | 0 | 1 | 1 |
| | 0 | 1 | 1 | 1 | 0 | 1 | 0 | 0 | 0 | 0 | 1 | 1 | 0 | 1 |
| | 0 | 1 | 1 | 1 | 0 | 1 | 1 | 0 | 0 | 0 | 1 | 0 | 0 | 1 |
| * | 0 | 1 | 1 | 1 | 1 | 0 | 0 | 0 | 0 | 1 | 0 | 0 | 1 | 1 |
| | 0 | 1 | 1 | 1 | 1 | 0 | 1 | 1 | 1 | 0 | 0 | 1 | 0 | 1 |
| | 0 | 1 | 1 | 1 | 1 | 1 | 0 | 0 | 0 | 0 | 1 | 1 | 1 | 1 |
| | 0 | 1 | 1 | 1 | 1 | 1 | 1 | 0 | 0 | 0 | 0 | 0 | 0 | 0 |

* Depends on BCD code applied during 0 to 1 transition of $\overline{\text{EL}}$

$\overline{\text{EL}}$ = active-low latch enable input

$\overline{\text{BI}}$ = active-low ripple-blanking input

$\overline{\text{LT}}$ = active-low lamp-test input

O.2.73 4512 (8-In MUX w/3-state Out)

This device is a 8-input multiplexer with 3-state outputs.

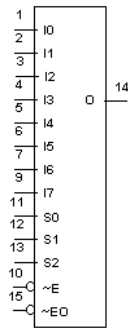

Multiplexer truth table:

| | | SELECT | | | INPUTS | | | | | | | | OUTPUT |
|-----------------|----------------|--------|---|---|--------|----|----|----|----|----|----|----|--------|
| \overline{EO} | \overline{E} | C | B | A | I0 | I1 | I2 | I3 | I4 | I5 | I6 | I7 | O |
| 0 | 1 | X | X | X | X | X | X | X | X | X | X | X | 0 |
| 0 | 0 | 0 | 0 | 0 | 0 | X | X | X | X | X | X | X | 0 |
| 0 | 0 | 0 | 0 | 0 | 1 | X | X | X | X | X | X | X | 1 |
| 0 | 0 | 0 | 0 | 1 | X | 0 | X | X | X | X | X | X | 0 |
| 0 | 0 | 0 | 0 | 1 | X | 1 | X | X | X | X | X | X | 1 |
| 0 | 0 | 0 | 1 | 0 | X | X | 0 | X | X | X | X | X | 0 |
| 0 | 0 | 0 | 1 | 0 | X | X | 1 | X | X | X | X | X | 1 |
| 0 | 0 | 0 | 1 | 1 | X | X | X | 0 | X | X | X | X | 0 |
| 0 | 0 | 0 | 1 | 1 | X | X | X | 1 | X | X | X | X | 1 |
| 0 | 0 | 1 | 0 | 0 | X | X | X | X | 0 | X | X | X | 0 |
| 0 | 0 | 1 | 0 | 0 | X | X | X | X | 1 | X | X | X | 1 |
| 0 | 0 | 1 | 0 | 1 | X | X | X | X | X | 0 | X | X | 0 |
| 0 | 0 | 1 | 0 | 1 | X | X | X | X | X | 1 | X | X | 1 |
| 0 | 0 | 1 | 1 | 0 | X | X | X | X | X | X | 0 | X | 0 |
| 0 | 0 | 1 | 1 | 0 | X | X | X | X | X | X | 1 | X | 1 |
| 0 | 0 | 1 | 1 | 1 | X | X | X | X | X | X | X | 0 | 0 |
| 0 | 0 | 1 | 1 | 1 | X | X | X | X | X | X | X | 1 | 1 |
| 1 | X | X | X | X | X | X | X | X | X | X | X | X | Z |

\overline{EO} = Output Enable (Active-low)
 \overline{E} = Enable input (Active-low)
 \overline{Z} = High impedance

O.2.74 4514 (1-of-16 Dec/DEMUX w/Input latches)

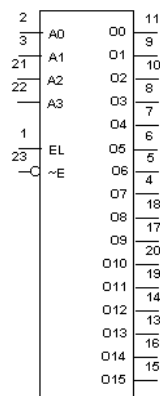

This device is a 1-of-16 decoder/demultiplexer with input latches. The input latches allow for the user to hold a previous input with the enable input while the inputs change.

1-of-16 decoder/demultiplexer truth table:

| \overline{E} | INPUTS | | | | OUTPUTS | | | | | | | | | | | | | | | | |
|----------------|--------|----|----|----|---------|----|----|----|----|----|----|----|----|----|-----|-----|-----|-----|-----|-----|---|
| | A3 | A2 | A1 | A0 | O0 | O1 | O2 | O3 | O4 | O5 | O6 | O7 | O8 | O9 | O10 | O11 | O12 | O13 | O14 | O15 | |
| 1 | X | X | X | X | 0 | 0 | 0 | 0 | 0 | 0 | 0 | 0 | 0 | 0 | 0 | 0 | 0 | 0 | 0 | 0 | 0 |
| 0 | 0 | 0 | 0 | 0 | 1 | 0 | 0 | 0 | 0 | 0 | 0 | 0 | 0 | 0 | 0 | 0 | 0 | 0 | 0 | 0 | 0 |
| 0 | 0 | 0 | 0 | 1 | 0 | 1 | 0 | 0 | 0 | 0 | 0 | 0 | 0 | 0 | 0 | 0 | 0 | 0 | 0 | 0 | 0 |
| 0 | 0 | 0 | 1 | 0 | 0 | 0 | 1 | 0 | 0 | 0 | 0 | 0 | 0 | 0 | 0 | 0 | 0 | 0 | 0 | 0 | 0 |
| 0 | 0 | 1 | 0 | 0 | 0 | 0 | 0 | 1 | 0 | 0 | 0 | 0 | 0 | 0 | 0 | 0 | 0 | 0 | 0 | 0 | 0 |
| 0 | 0 | 1 | 0 | 1 | 0 | 0 | 0 | 0 | 1 | 0 | 0 | 0 | 0 | 0 | 0 | 0 | 0 | 0 | 0 | 0 | 0 |
| 0 | 0 | 1 | 1 | 0 | 0 | 0 | 0 | 0 | 0 | 1 | 0 | 0 | 0 | 0 | 0 | 0 | 0 | 0 | 0 | 0 | 0 |
| 0 | 0 | 1 | 1 | 1 | 0 | 0 | 0 | 0 | 0 | 0 | 1 | 0 | 0 | 0 | 0 | 0 | 0 | 0 | 0 | 0 | 0 |
| 0 | 1 | 0 | 0 | 0 | 0 | 0 | 0 | 0 | 0 | 0 | 0 | 1 | 0 | 0 | 0 | 0 | 0 | 0 | 0 | 0 | 0 |
| 0 | 1 | 0 | 0 | 1 | 0 | 0 | 0 | 0 | 0 | 0 | 0 | 0 | 1 | 0 | 0 | 0 | 0 | 0 | 0 | 0 | 0 |
| 0 | 1 | 0 | 1 | 0 | 0 | 0 | 0 | 0 | 0 | 0 | 0 | 0 | 0 | 1 | 0 | 0 | 0 | 0 | 0 | 0 | 0 |
| 0 | 1 | 0 | 1 | 1 | 0 | 0 | 0 | 0 | 0 | 0 | 0 | 0 | 0 | 0 | 1 | 0 | 0 | 0 | 0 | 0 | 0 |
| 0 | 1 | 1 | 0 | 0 | 0 | 0 | 0 | 0 | 0 | 0 | 0 | 0 | 0 | 0 | 0 | 1 | 0 | 0 | 0 | 0 | 0 |
| 0 | 1 | 1 | 0 | 1 | 0 | 0 | 0 | 0 | 0 | 0 | 0 | 0 | 0 | 0 | 0 | 0 | 1 | 0 | 0 | 0 | 0 |
| 0 | 1 | 1 | 1 | 0 | 0 | 0 | 0 | 0 | 0 | 0 | 0 | 0 | 0 | 0 | 0 | 0 | 0 | 1 | 0 | 0 | 0 |
| 0 | 1 | 1 | 1 | 1 | 0 | 0 | 0 | 0 | 0 | 0 | 0 | 0 | 0 | 0 | 0 | 0 | 0 | 0 | 1 | 0 | 0 |
| 0 | 1 | 1 | 1 | 1 | 0 | 0 | 0 | 0 | 0 | 0 | 0 | 0 | 0 | 0 | 0 | 0 | 0 | 0 | 0 | 1 | 0 |
| 0 | 1 | 1 | 1 | 1 | 1 | 0 | 0 | 0 | 0 | 0 | 0 | 0 | 0 | 0 | 0 | 0 | 0 | 0 | 0 | 0 | 1 |

O.2.75 4515 (1-of-16 Dec/DEMUX w/Input latches)

This device is a 1-of-16 decoder/demultiplexer with input latches. The input latches allow for the user to hold a previous input with the enable input while the inputs change.

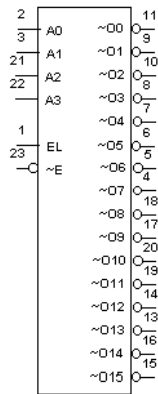

1-of-16 decoder/demultiplexer truth table:

| \bar{E} | INPUTS | | | | OUTPUTS | | | | | | | | | | | | | | | |
|-----------|--------|----|----|----|---------|----|----|----|----|----|----|----|----|----|-----|-----|-----|-----|-----|-----|
| | A3 | A2 | A1 | A0 | O0 | O1 | O2 | O3 | O4 | O5 | O6 | O7 | O8 | O9 | O10 | O11 | O12 | O13 | O14 | O15 |
| 1 | X | X | X | X | 1 | 1 | 1 | 1 | 1 | 1 | 1 | 1 | 1 | 1 | 1 | 1 | 1 | 1 | 1 | 1 |
| 0 | 0 | 0 | 0 | 0 | 0 | 1 | 1 | 1 | 1 | 1 | 1 | 1 | 1 | 1 | 1 | 1 | 1 | 1 | 1 | 1 |
| 0 | 0 | 0 | 0 | 1 | 1 | 0 | 1 | 1 | 1 | 1 | 1 | 1 | 1 | 1 | 1 | 1 | 1 | 1 | 1 | 1 |
| 0 | 0 | 0 | 1 | 0 | 1 | 1 | 0 | 1 | 1 | 1 | 1 | 1 | 1 | 1 | 1 | 1 | 1 | 1 | 1 | 1 |
| 0 | 0 | 0 | 1 | 1 | 1 | 1 | 1 | 0 | 1 | 1 | 1 | 1 | 1 | 1 | 1 | 1 | 1 | 1 | 1 | 1 |
| 0 | 0 | 1 | 0 | 0 | 1 | 1 | 1 | 1 | 0 | 1 | 1 | 1 | 1 | 1 | 1 | 1 | 1 | 1 | 1 | 1 |
| 0 | 0 | 1 | 0 | 1 | 1 | 1 | 1 | 1 | 1 | 0 | 1 | 1 | 1 | 1 | 1 | 1 | 1 | 1 | 1 | 1 |
| 0 | 0 | 1 | 1 | 0 | 1 | 1 | 1 | 1 | 1 | 1 | 0 | 1 | 1 | 1 | 1 | 1 | 1 | 1 | 1 | 1 |
| 0 | 0 | 1 | 1 | 1 | 1 | 1 | 1 | 1 | 1 | 1 | 1 | 0 | 1 | 1 | 1 | 1 | 1 | 1 | 1 | 1 |
| 0 | 1 | 0 | 0 | 0 | 1 | 1 | 1 | 1 | 1 | 1 | 1 | 1 | 0 | 1 | 1 | 1 | 1 | 1 | 1 | 1 |
| 0 | 1 | 0 | 0 | 1 | 1 | 1 | 1 | 1 | 1 | 1 | 1 | 1 | 1 | 0 | 1 | 1 | 1 | 1 | 1 | 1 |
| 0 | 1 | 0 | 1 | 0 | 1 | 1 | 1 | 1 | 1 | 1 | 1 | 1 | 1 | 1 | 0 | 1 | 1 | 1 | 1 | 1 |
| 0 | 1 | 0 | 1 | 1 | 1 | 1 | 1 | 1 | 1 | 1 | 1 | 1 | 1 | 1 | 1 | 0 | 1 | 1 | 1 | 1 |
| 0 | 1 | 1 | 0 | 0 | 1 | 1 | 1 | 1 | 1 | 1 | 1 | 1 | 1 | 1 | 1 | 1 | 0 | 1 | 1 | 1 |
| 0 | 1 | 1 | 0 | 1 | 1 | 1 | 1 | 1 | 1 | 1 | 1 | 1 | 1 | 1 | 1 | 1 | 1 | 0 | 1 | 1 |
| 0 | 1 | 1 | 1 | 0 | 1 | 1 | 1 | 1 | 1 | 1 | 1 | 1 | 1 | 1 | 1 | 1 | 1 | 1 | 0 | 1 |
| 0 | 1 | 1 | 1 | 1 | 1 | 1 | 1 | 1 | 1 | 1 | 1 | 1 | 1 | 1 | 1 | 1 | 1 | 1 | 1 | 0 |

O.2.76 4516 (Binary up/down Counter)

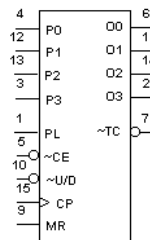

This binary up/down counter counts from 0000 to 1111 in binary (0 to 15 in decimal).

Binary up/down counter truth table:

| MR | $\overline{\text{PL}}$ | $\overline{\text{UP/DN}}$ | CE | CP | MODE |
|----|------------------------|---------------------------|----|----|---------------|
| 0 | 1 | X | X | X | PARALLEL LOAD |
| 0 | 0 | X | 1 | X | NO CHANGE |
| 0 | 0 | 0 | 0 | . | COUNT DOWN |
| 0 | 0 | 1 | 0 | . | COUNT UP |
| 1 | X | X | X | X | RESET |

O.2.77 4518 (Dual BCD Counter)

The 4518 device is a dual 4-bit internally synchronous BCD counter.

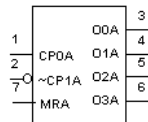

BCD counter truth table:

| $\overline{\text{CP0}}$ | CP1 | MR | MODE |
|-------------------------|-----|----|---------------------|
| . | 1 | 0 | COUNTER ADVANCES |
| 0 | , | 0 | COUNTER ADVANCES |
| , | X | 0 | NO CHANGE |
| X | . | 0 | NO CHANGE |
| . | 0 | 0 | NO CHANGE |
| 1 | , | 0 | NO CHANGE |
| X | X | 1 | O0 TO O3 = LOW |

O.2.78 4519 (Quad Multiplexer)

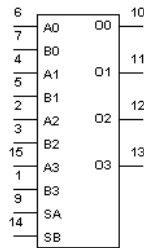

The 4519 device provides four multiplexing circuits with common select inputs (SA, SB). Each circuit contains two inputs (An, Bn) and one output (On).

O.2.79 4520 (Dual Binary Counter)

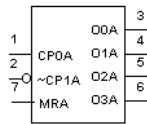

The 4520 device is a dual 4-bit internally synchronous binary counter.

Binary counter truth table:

| $\overline{\text{CP0}}$ | CP1 | MR | MODE |
|-------------------------|-----|----|------------------|
| . | 1 | 0 | COUNTER ADVANCES |
| 0 | , | 0 | COUNTER ADVANCES |
| , | X | 0 | NO CHANGE |
| X | . | 0 | NO CHANGE |
| . | 0 | 0 | NO CHANGE |
| 1 | , | 0 | NO CHANGE |
| X | X | 1 | O0 TO O3 = LOW |

O.2.80 4522 (4-bit BCD Down Counter)

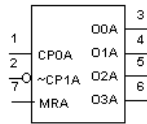

The 4522 device is a synchronous programmable 4-bit BCD down counter with an active HIGH and an active LOW clock input (CP0, CP1), an asynchronous parallel load input (PL), four parallel inputs (P0 to P3), a cascade feedback input (CF), four buffered parallel outputs (O0 to O3), a terminal count output (TC) and an overriding asynchronous master reset input (MR).

O.2.81 4526 (4-bit Bin Down Counter)

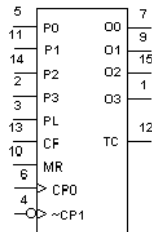

The 4526 device is a synchronous programmable 4-bit binary down counter with an active HIGH and an active LOW clock input (CP0, $\overline{\text{CP1}}$), an asynchronous parallel load input (PL), four parallel inputs (P0 to P3), a cascade feedback input (CF), four buffered parallel outputs (O0 to O3), a terminal count output (TC) and an overriding asynchronous master reset input (MR).

O.2.82 4531 (13-input Checker/Generator)

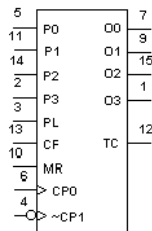

The 4531 device is a parity checker/generator with 13 parity inputs (I0 to I12) and a parity output (O).

Truth table:

| INPUTS | | | | | | | | | | | | OUTPUTS | |
|--------------------------------|----|----|----|----|----|----|----|----|----|-----|-----|---------|---|
| I0 | I1 | I2 | I3 | I4 | I5 | I6 | I7 | I8 | I9 | I10 | I11 | I12 | O |
| 0 | 0 | 0 | 0 | 0 | 0 | 0 | 0 | 0 | 0 | 0 | 0 | 0 | 0 |
| any odd number of inputs HIGH | | | | | | | | | | | | 1 | |
| any even number of inputs HIGH | | | | | | | | | | | | 0 | |
| 1 | 1 | 1 | 1 | 1 | 1 | 1 | 1 | 1 | 1 | 1 | 1 | 1 | 1 |

1 = HIGH state (the more positive voltage)
0 = LOW state (the less positive voltage)

O.2.83 4532 (8-bit Priority Enc)

This device is an 8-bit priority encoder.

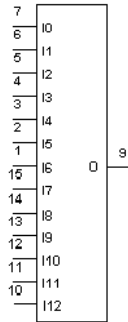

Priority encoder truth table:

| E1 | INPUTS | | | | | | | OUTPUTS | | | | | |
|----|--------|---|---|---|---|---|---|---------|----|----|----|----|----|
| | 0 | 1 | 2 | 3 | 4 | 5 | 6 | 7 | GS | O2 | O1 | O0 | EO |
| 0 | X | X | X | X | X | X | X | X | 0 | 0 | 0 | 0 | 0 |
| 1 | 0 | 0 | 0 | 0 | 0 | 0 | 0 | 0 | 0 | 0 | 0 | 0 | 1 |
| 1 | 1 | X | X | X | X | X | X | X | 1 | 1 | 1 | 1 | 0 |
| 1 | 0 | 1 | X | X | X | X | X | X | 1 | 1 | 1 | 0 | 0 |
| 1 | 0 | 0 | 1 | X | X | X | X | X | 1 | 1 | 0 | 1 | 0 |
| 1 | 0 | 0 | 0 | 1 | X | X | X | X | 1 | 1 | 0 | 0 | 0 |
| 1 | 0 | 0 | 0 | 0 | 1 | X | X | X | 1 | 0 | 1 | 1 | 0 |
| 1 | 0 | 0 | 0 | 0 | 0 | 1 | X | X | 1 | 0 | 1 | 0 | 0 |
| 1 | 0 | 0 | 0 | 0 | 0 | 0 | 1 | X | 1 | 0 | 0 | 1 | 0 |
| 1 | 0 | 0 | 0 | 0 | 0 | 0 | 0 | 1 | 1 | 0 | 0 | 0 | 0 |

O.2.84 4539 (Dual 4-input Multiplexer)

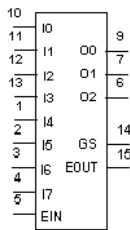

The 4539 device is a dual 4-input multiplexer with common select logic. Each multiplexer has four multiplexer inputs (I0 to I3), an active LOW enable input (\bar{E}) and a multiplexer output (O).

O.2.85 4543 (BCD-to-seven segment latch/dec/driver)

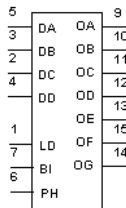

The 4543 device is a BCD to 7-segment latch/decoder/driver for liquid crystal and LED displays. It has four address inputs (DA to DD), an active HIGH latch disable input (LD), an active HIGH blanking input (BI), an active HIGH phase input (PH) and seven buffered segment outputs (Oa to Og).

7-segment latch/decoder/driver truth table:

| INPUTS | | | | | | | OUTPUTS | | | | | | | DISPLAY |
|----------|----|------|----------|----|----|----|------------------|----|----|----|----|----|----|----------|
| LD | BI | PH * | DD | DC | DB | DA | Oa | Ob | Oc | Od | Oe | Of | Og | |
| X | 1 | 0 | X | X | X | X | 0 | 0 | 0 | 0 | 0 | 0 | 0 | BLANK |
| 1 | 0 | 0 | 0 | 0 | 0 | 0 | 1 | 1 | 1 | 1 | 1 | 1 | 0 | 0 |
| 1 | 0 | 0 | 0 | 0 | 0 | 1 | 0 | 1 | 1 | 0 | 0 | 0 | 0 | 1 |
| 1 | 0 | 0 | 0 | 0 | 1 | 0 | 1 | 1 | 0 | 1 | 1 | 0 | 1 | 2 |
| 1 | 0 | 0 | 0 | 0 | 1 | 1 | 1 | 1 | 1 | 1 | 0 | 0 | 1 | 3 |
| 1 | 0 | 0 | 0 | 1 | 0 | 0 | 0 | 1 | 1 | 0 | 0 | 1 | 1 | 4 |
| 1 | 0 | 0 | 0 | 1 | 0 | 1 | 1 | 0 | 1 | 1 | 0 | 1 | 1 | 5 |
| 1 | 0 | 0 | 0 | 1 | 1 | 0 | 1 | 0 | 1 | 1 | 1 | 1 | 1 | 6 |
| 1 | 0 | 0 | 0 | 1 | 1 | 1 | 1 | 1 | 1 | 0 | 0 | 0 | 0 | 7 |
| 1 | 0 | 0 | 1 | 0 | 0 | 0 | 1 | 1 | 1 | 1 | 1 | 1 | 1 | 8 |
| 1 | 0 | 0 | 1 | 0 | 0 | 1 | 1 | 1 | 1 | 1 | 0 | 1 | 1 | 9 |
| 1 | 0 | 0 | 1 | 0 | 1 | 0 | 0 | 0 | 0 | 0 | 0 | 0 | 0 | BLANK |
| 1 | 0 | 0 | 1 | 0 | 1 | 1 | 0 | 0 | 0 | 0 | 0 | 0 | 0 | BLANK |
| 1 | 0 | 0 | 1 | 1 | 0 | 0 | 0 | 0 | 0 | 0 | 0 | 0 | 0 | BLANK |
| 1 | 0 | 0 | 1 | 1 | 0 | 1 | 0 | 0 | 0 | 0 | 0 | 0 | 0 | BLANK |
| 1 | 0 | 0 | 1 | 1 | 1 | 0 | 0 | 0 | 0 | 0 | 0 | 0 | 0 | BLANK |
| 1 | 0 | 0 | 1 | 1 | 1 | 1 | 0 | 0 | 0 | 0 | 0 | 0 | 0 | BLANK |
| 0 | 0 | 0 | X | X | X | X | ** | | | | | | | |
| as above | 1 | | as above | | | | inverse as above | | | | | | | as above |

1 = HIGH state (the more positive voltage)

0 = LOW state (the less positive voltage)

X = state is immaterial

* For liquid crystal displays, apply a square-wave to PH.
For common cathode LED displays, select PH = LOW.
For common anode LED displays, select PH = HIGH.

** Depends upon the BCD-code previously applied when LD = HIGH

O.2.86 4544 (BCD-to-seven segment latch/dec)

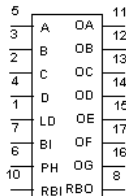

The 4544 BCD (Binary-Coded Decimal) -to-seven segment latch/decoder/driver is designed for use with liquid crystal readouts. It is constructed with complementary MOS (CMOS) enhancement mode devices. The circuit provides the functions of a 4-bit storage latch and an 8421 BCD-to-seven segment decoder and driver.

7-segment latch/decoder/driver truth table:

| INPUTS | | | | | | | | OUTPUTS | | | | | | | | |
|--------|----|----|------|---|---|---|---|---------|--------------------------------------|---|---|---|---|---|---|-------------------|
| RBI | LD | B1 | Ph * | D | C | B | A | RBO | a | b | c | d | e | f | g | DISPLAY |
| X | X | 1 | 0 | X | X | X | X | 0 | 0 | 0 | 0 | 0 | 0 | 0 | 0 | BLANK |
| 1 | 1 | 0 | 0 | 0 | 0 | 0 | 0 | 1 | 0 | 0 | 0 | 0 | 0 | 0 | 0 | BLANK |
| 0 | 1 | 0 | 0 | 0 | 0 | 0 | 0 | 0 | 1 | 1 | 1 | 1 | 1 | 1 | 0 | 0 |
| X | 1 | 0 | 0 | 0 | 0 | 0 | 1 | 0 | 0 | 1 | 1 | 0 | 0 | 0 | 0 | 1 |
| X | 1 | 0 | 0 | 0 | 0 | 1 | 0 | 0 | 1 | 1 | 0 | 1 | 1 | 0 | 1 | 2 |
| X | 1 | 0 | 0 | 0 | 0 | 1 | 1 | 0 | 1 | 1 | 1 | 1 | 0 | 0 | 1 | 3 |
| X | 1 | 0 | 0 | 0 | 1 | 0 | 0 | 0 | 0 | 1 | 1 | 0 | 0 | 1 | 1 | 4 |
| X | 1 | 0 | 0 | 0 | 1 | 0 | 1 | 0 | 1 | 0 | 1 | 1 | 0 | 1 | 1 | 5 |
| X | 1 | 0 | 0 | 0 | 1 | 1 | 0 | 0 | 1 | 0 | 1 | 1 | 1 | 1 | 1 | 6 |
| X | 1 | 0 | 0 | 0 | 1 | 1 | 1 | 0 | 1 | 1 | 1 | 0 | 0 | 0 | 0 | 7 |
| X | 1 | 0 | 0 | 1 | 0 | 0 | 0 | 0 | 1 | 1 | 1 | 1 | 1 | 1 | 1 | 8 |
| X | 1 | 0 | 0 | 1 | 0 | 0 | 1 | 0 | 1 | 1 | 1 | 1 | 0 | 1 | 1 | 9 |
| X | 1 | 0 | 0 | 1 | 0 | 1 | 0 | 0 | 0 | 0 | 0 | 0 | 0 | 0 | 0 | BLANK |
| X | 1 | 0 | 0 | 1 | 0 | 1 | 1 | 0 | 0 | 0 | 0 | 0 | 0 | 0 | 0 | BLANK |
| X | 1 | 0 | 0 | 1 | 1 | 0 | 0 | 0 | 0 | 0 | 0 | 0 | 0 | 0 | 0 | BLANK |
| X | 1 | 0 | 0 | 1 | 1 | 1 | 0 | 0 | 0 | 0 | 0 | 0 | 0 | 0 | 0 | BLANK |
| X | 1 | 0 | 0 | 1 | 1 | 1 | 1 | 0 | 0 | 0 | 0 | 0 | 0 | 0 | 0 | BLANK |
| X | 0 | 0 | 0 | X | X | X | X | | ** | | | | | | | ** |
| † | † | † | † | | | † | | † | Inverse of Output Combinations Above | | | | | | | Dis-play as above |

X Don't care
 † Above combinations

*

**

$$RBO = RBI \cdot (\overline{ABCD})$$

O.2.87 4555 (Dual 1-of-4 Dec/DEMUX)

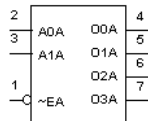

The 4555 device is a dual 1-of-4 decoder/demultiplexer. Each has two address inputs (A0 and A1), an active LOW enable input (\overline{E}) and four mutually exclusive outputs that are active HIGH (O0 to O3).

Decoder/demultiplexer truth table:

| INPUTS | | | OUTPUTS | | | |
|----------------|----|----|-----------------|-----------------|-----------------|-----------------|
| \overline{E} | A0 | A1 | $\overline{O0}$ | $\overline{O1}$ | $\overline{O2}$ | $\overline{O3}$ |
| 0 | 0 | 0 | 1 | 0 | 0 | 0 |
| 0 | 1 | 0 | 0 | 1 | 0 | 0 |
| 0 | 0 | 1 | 0 | 0 | 1 | 0 |
| 0 | 1 | 1 | 0 | 0 | 0 | 1 |
| 1 | X | X | 0 | 0 | 0 | 0 |

1 = HIGH state (the more positive voltage)
 0 = LOW state (the less positive voltage)
 X = state is immaterial

O.2.88 4556 (Dual 1-of-4 Dec/DEMUX)



This device contains two independent 1-of-4 decoders/demultiplexers.

Decoders/demultiplexer truth table:

| INPUTS | | | OUTPUTS | | | |
|----------------|----|----|-----------------|-----------------|-----------------|-----------------|
| \overline{E} | A0 | A1 | $\overline{O0}$ | $\overline{O1}$ | $\overline{O2}$ | $\overline{O3}$ |
| 0 | 0 | 0 | 0 | 1 | 1 | 1 |
| 0 | 1 | 0 | 1 | 0 | 1 | 1 |
| 0 | 0 | 1 | 1 | 1 | 0 | 1 |
| 0 | 1 | 1 | 1 | 1 | 1 | 0 |
| 1 | X | X | 1 | 1 | 1 | 1 |

O.2.89 4585 (4-bit Comparator)

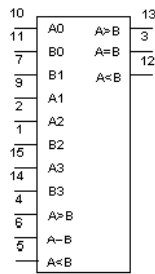

The 4585 device is a 4-bit magnitude comparator that compares two 4-bit words (A and B), whether they are “less than”, “equal to”, or “greater than”. Each word has four parallel inputs (A0 to A3 and B0 to B3).

4-bit comparator truth table:

| COMPARING INPUTS | | | | CASCADING INPUTS | | | OUTPUTS | | |
|--------------------------------|--------------------------------|--------------------------------|--------------------------------|------------------|------|------|---------|------|------|
| A3, B3 | A2, B2 | A1, B1 | A0, B0 | IA>B | IA<B | IA=B | OA>B | OA<B | OA=B |
| A ₃ >B ₃ | X | X | X | 1 | X | X | 1 | 0 | 0 |
| A ₃ <B ₃ | X | X | X | X | X | X | 0 | 1 | 0 |
| A ₃ =B ₃ | A ₂ >B ₂ | X | X | 1 | X | X | 1 | 0 | 0 |
| A ₃ =B ₃ | A ₂ <B ₂ | X | X | X | X | X | 0 | 1 | 0 |
| A ₃ =B ₃ | A ₂ =B ₂ | A ₁ >B ₁ | X | 1 | X | X | 1 | 0 | 0 |
| A ₃ =B ₃ | A ₂ =B ₂ | A ₁ <B ₁ | X | X | X | X | 0 | 1 | 0 |
| A ₃ =B ₃ | A ₂ =B ₂ | A ₁ =B ₁ | A ₀ >B ₀ | 1 | X | X | 1 | 0 | 0 |
| A ₃ =B ₃ | A ₂ =B ₂ | A ₁ =B ₁ | A ₀ <B ₀ | X | X | X | 0 | 1 | 0 |
| A ₃ =B ₃ | A ₂ =B ₂ | A ₁ =B ₁ | A ₀ =B ₀ | X | 0 | 1 | 0 | 0 | 1 |
| A ₃ =B ₃ | A ₂ =B ₂ | A ₁ =B ₁ | A ₀ =B ₀ | 1 | 0 | 0 | 1 | 0 | 0 |
| A ₃ =B ₃ | A ₂ =B ₂ | A ₁ =B ₁ | A ₀ =B ₀ | X | 1 | 0 | 0 | 1 | 0 |
| A ₃ =B ₃ | A ₂ =B ₂ | A ₁ =B ₁ | A ₀ =B ₀ | X | 1 | 1 | 0 | 1 | 1 |
| A ₃ =B ₃ | A ₂ =B ₂ | A ₁ =B ₁ | A ₀ =B ₀ | 0 | 0 | 0 | 0 | 0 | 0 |

1 = HIGH state (the more positive voltage)

0 = LOW state (the less positive voltage)

X = state is immaterial

Appendix P

Functions (74XX Series)

| | | |
|--------|--------------------------------------------------|------|
| P.1 | Standard TTL | P-1 |
| P.2 | Schottky TTL | P-1 |
| P.3 | Low-Power Schottky TTL | P-2 |
| P.4 | Tiny Logic | P-2 |
| P.5 | 74xx | P-2 |
| P.5.1 | 74xx00 (Quad 2-In NAND) | P-2 |
| P.5.2 | 74xx02 (Quad 2-In NOR) | P-3 |
| P.5.3 | 74xx03 (Quad 2-In NAND (Ls-OC)) | P-3 |
| P.5.4 | 74xx04 (Hex INVERTER) | P-3 |
| P.5.5 | 74xx05 (Hex INVERTER (OC)) | P-4 |
| P.5.6 | 74xx06 (Hex INVERTER (OC)) | P-4 |
| P.5.7 | 74xx07 (Hex BUFFER (OC)) | P-5 |
| P.5.8 | 74xx08 (Quad 2-In AND) | P-5 |
| P.5.9 | 74xx09 (Quad 2-In AND (OC)) | P-5 |
| P.5.10 | 74xx10 (Tri 3-In NAND) | P-6 |
| P.5.11 | 74xx100 (8-Bit Bist Latch) | P-6 |
| P.5.12 | 74xx107 (Dual JK FF(clr)) | P-7 |
| P.5.13 | 74xx109 (Dual JK FF (+edge, pre, clr)) | P-7 |
| P.5.14 | 74xx11 (Tri 3-In AND) | P-7 |
| P.5.15 | 74xx112 (Dual JK FF(-edge, pre, clr)) | P-8 |
| P.5.16 | 74xx113 (Dual JK MS-SLV FF (-edge, pre)) | P-8 |
| P.5.17 | 74xx114 (Dual JK FF (-edge, pre, com clk & clr)) | P-9 |
| P.5.18 | 74xx116 (Dual 4-bit latches (clr)) | P-9 |
| P.5.19 | 74xx12 (Tri 3-In NAND (OC)) | P-10 |
| P.5.20 | 74xx125 (Quad bus BUFFER w/3-state Out) | P-11 |
| P.5.21 | 74xx126 (Quad bus BUFFER w/3-state Out) | P-11 |
| P.5.22 | 74xx132 (Quad 2-In NAND (Schmitt)) | P-11 |
| P.5.23 | 74xx133 (13-In NAND) | P-12 |
| P.5.24 | 74xx134 (12-In NAND w/3-state Out) | P-12 |
| P.5.25 | 74xx135 (Quad Ex-OR/NOR Gate) | P-13 |

| | | |
|--------|-----------------------------------------------|------|
| P.5.26 | 74xx136 (Quad 2-in Exc-OR gate) | P-13 |
| P.5.27 | 74xx138 (3-to-8 Dec) | P-13 |
| P.5.28 | 74xx139 (Dual 2-to-4 Dec/DEMUX) | P-14 |
| P.5.29 | 74xx14 (Hex INVERTER (Schmitt)) | P-14 |
| P.5.30 | 74xx145 (BCD-to-Decimal Dec) | P-15 |
| P.5.31 | 74xx147 (10-to-4 Priority Enc) | P-16 |
| P.5.32 | 74xx148 (8-to-3 Priority Enc) | P-16 |
| P.5.33 | 74xx15 (3 3-Input AND) | P-17 |
| P.5.34 | 74xx150 (1-of-16 Data Sel/MUX) | P-17 |
| P.5.35 | 74xx151 (1-of-8 Data Sel/MUX) | P-18 |
| P.5.36 | 74xx152 (Data Sel/MUX) | P-18 |
| P.5.37 | 74xx153 (Dual 4-to-1 Data Sel/MUX) | P-19 |
| P.5.38 | 74xx154 (4-to-16 Dec/DEMUX) | P-19 |
| P.5.39 | 74xx155 (Dual 2-to-4 Dec/DEMUX) | P-20 |
| P.5.40 | 74xx156 (Dual 2-to-4 Dec/DEMUX (OC)) | P-21 |
| P.5.41 | 74xx157 (Quad 2-to-1 Data Sel/MUX) | P-21 |
| P.5.42 | 74xx158 (Quad 2-to-1 Data Sel/MUX) | P-21 |
| P.5.43 | 74xx159 (4-to-16 Dec/DEMUX (OC)) | P-22 |
| P.5.44 | 74xx16 (Hex INVERTER (OC)) | P-23 |
| P.5.45 | 74xx160 (Sync 4-bit Decade Counter (clr)) | P-23 |
| P.5.46 | 74xx161 (Sync 4-bit Bin Counter) | P-24 |
| P.5.47 | 74xx162 (Sync 4-bit Decade Counter) | P-25 |
| P.5.48 | 74xx163 (Sync 4-bit Binary Counter) | P-25 |
| P.5.49 | 74xx164 (8-bit Parallel-Out Serial Shift Reg) | P-26 |
| P.5.50 | 74xx165 (Parallel-load 8-bit Shift Reg) | P-27 |
| P.5.51 | 74xx166 (Parallel-load 8-bit Shift Reg) | P-27 |
| P.5.52 | 74xx169 (Sync 4-bit up/down Binary Counter) | P-28 |
| P.5.53 | 74xx17 (Hex BUFFER (OC)) | P-28 |
| P.5.54 | 74xx173 (4-bit D-type Reg w/3-state Out) | P-29 |
| P.5.55 | 74xx174 (Hex D-type FF (clr)) | P-29 |
| P.5.56 | 74xx175 (Quad D-type FF (clr)) | P-30 |
| P.5.57 | 74xx180 (9-bit Odd/even Par GEN) | P-30 |
| P.5.58 | 74xx181 (Alu/Function Generator) | P-31 |
| P.5.59 | 74xx182 (Look-ahead Carry GEN) | P-31 |
| P.5.60 | 74xx190 (Sync BCD up/down Counter) | P-33 |
| P.5.61 | 74xx191 (Sync 4-bit up/down Counter) | P-33 |
| P.5.62 | 74xx192 (Sync BCD Up/down Counter) | P-34 |
| P.5.63 | 74xx193 (Sync 4-bit Bin Up/down Counter) | P-34 |
| P.5.64 | 74xx194 (4-bit Bidirect Univ. Shift Reg) | P-35 |
| P.5.65 | 74xx195 (4-bit Parallel-Access Shift Reg) | P-35 |
| P.5.66 | 74xx198 (8-bit Shift Reg (sh/shr ctrl)) | P-36 |
| P.5.67 | 74xx199 (8-bit Shift Reg (sh/lid ctrl)) | P-37 |

| | | |
|---------|---------------------------------------------------|------|
| P.5.68 | 74xx20 (Dual 4-In NAND) | P-38 |
| P.5.69 | 74xx21 (Dual 4-In AND) | P-38 |
| P.5.70 | 74xx22 (Dual 4-In NAND (OC)) | P-38 |
| P.5.71 | 74xx238 (3-to-8 line Dec/DEMUX) | P-39 |
| P.5.72 | 74xx240 (Octal BUFFER w/3-state Out) | P-39 |
| P.5.73 | 74xx241 (Octal BUFFER w/3-state Out) | P-40 |
| P.5.74 | 74xx244 (Octal BUFFER w/3-state Out) | P-40 |
| P.5.75 | 74xx246 (BCD-to-seven segment dec) | P-41 |
| P.5.76 | 74xx247 (BCD-to-seven segment dec) | P-42 |
| P.5.77 | 74xx248 (BCD-to-seven segment dec) | P-43 |
| P.5.78 | 74xx249 (BCD-to-seven segment dec) | P-44 |
| P.5.79 | 74xx25 (Dual 4-In NOR w/Strobe) | P-45 |
| P.5.80 | 74xx251 (Data Sel/MUX w/3-state Out) | P-45 |
| P.5.81 | 74xx253 (Dual 4-to-1 Data Sel/MUX w/3-state Out) | P-46 |
| P.5.82 | 74xx257 (Quad 2-to-1 line Data Sel/MUX) | P-46 |
| P.5.83 | 74xx258 (Quad 2-to-1 line Data Sel/MUX) | P-47 |
| P.5.84 | 74xx259 (8-bit Latch) | P-47 |
| P.5.85 | 74xx26 (Quad 2-In NAND (OC)) | P-47 |
| P.5.86 | 74xx266 (Quad 2-In XNOR (OC)) | P-48 |
| P.5.87 | 74xx27 (Tri 3-In NOR) | P-48 |
| P.5.88 | 74xx273 (Octal D-type FF) | P-49 |
| P.5.89 | 74xx279 (Quad SR latches) | P-49 |
| P.5.90 | 74xx28 (Quad 2-In NOR) | P-50 |
| P.5.91 | 74xx280 (9-bit odd/even parity generator/checker) | P-50 |
| P.5.92 | 74xx283 (4-bit Bin Full Add) | P-50 |
| P.5.93 | 74xx290 (Decade Counter) | P-51 |
| P.5.94 | 74xx293 (4-bit Binary Counter) | P-51 |
| P.5.95 | 74xx298 (Quad 2-In MUX) | P-51 |
| P.5.96 | 74xx30 (8-In NAND) | P-52 |
| P.5.97 | 74xx32 (Quad 2-In OR) | P-52 |
| P.5.98 | 74xx33 (Quad 2-In NOR (OC)) | P-53 |
| P.5.99 | 74xx350 (4-bit Shifter w/3-state Out) | P-53 |
| P.5.100 | 74xx351 (Dual Data Sel/MUX w/3-state Out) | P-54 |
| P.5.101 | 74xx352 (Dual 4-to-1 Data Sel/MUX) | P-54 |
| P.5.102 | 74xx353 (Dual 4-to-1 Data Sel/MUX w/3-state Out) | P-55 |
| P.5.103 | 74xx365 (Hex Buffer/Driver w/3-state) | P-55 |
| P.5.104 | 74xx366 (Hex Inverter Buffer/Driver w/3-state) | P-56 |
| P.5.105 | 74xx367 (Hex Buffer/Driver w/3-state) | P-56 |
| P.5.106 | 74xx368 (Hex Inverter Buffer/Driver w/3-state) | P-57 |
| P.5.107 | 74xx37 (Quad 2-In NAND) | P-57 |
| P.5.108 | 74xx373 (Octal D-type Transparent Latches) | P-58 |
| P.5.109 | 74xx374 (Octal D-type FF (+edge)) | P-58 |

| | | |
|---------|----------------------------------------------------|------|
| P.5.110 | 74xx375 (4-bit Bistable Latches) | P-59 |
| P.5.111 | 74xx377 (Octal D-type FF w/en) | P-59 |
| P.5.112 | 74xx378 (Hex D-type FF w/en) | P-59 |
| P.5.113 | 74xx379 (Quad D-type FF w/en) | P-60 |
| P.5.114 | 74xx38 (Quad 2-In NAND (OC)) | P-60 |
| P.5.115 | 74xx39 (Quad 2-In NAND (OC)) | P-60 |
| P.5.116 | 74xx390 (Dual Div-by-2, Div-by-5 Counter) | P-61 |
| P.5.117 | 74xx393 (Dual 4-bit Binary Counter) | P-62 |
| P.5.118 | 74xx395 (4-bit Cascadable Shift Reg w/3-state Out) | P-63 |
| P.5.119 | 74xx40 (Dual 4-In NAND) | P-64 |
| P.5.120 | 74xx42 (4-BCD to 10-Decimal Dec) | P-64 |
| P.5.121 | 74xx43 (Exc-3-to-Decimal Dec) | P-65 |
| P.5.122 | 74xx44 (Exc-3-Gray-to-Decimal Dec) | P-66 |
| P.5.123 | 74xx445 (BCD-to-Decimal Dec) | P-67 |
| P.5.124 | 74xx45 (BCD-to-Decimal Dec) | P-68 |
| P.5.125 | 74xx46 (BCD-to-seven segment dec) | P-69 |
| P.5.126 | 74xx465 (Octal BUFFER w/3-state Out) | P-70 |
| P.5.127 | 74xx466 (Octal BUFFER w/3-state Out) | P-71 |
| P.5.128 | 74xx47 (BCD-to-seven segment dec) | P-71 |
| P.5.129 | 74xx48 (BCD-to-seven segment dec) | P-73 |
| P.5.130 | 74xx51 (AND-OR-INVERTER) | P-74 |
| P.5.131 | 74xx54 (4-wide AND-OR-INVERTER) | P-74 |
| P.5.132 | 74xx55 (2-wide 4-In AND-OR-INVERTER) | P-74 |
| P.5.133 | 74xx69 (Dual 4-bit Binary Counter) | P-75 |
| P.5.134 | 74xx72 (AND-gated JK MS-SLV FF (pre, clr)) | P-75 |
| P.5.135 | 74xx73 (Dual JK FF (clr)) | P-75 |
| P.5.136 | 74xx74 (Dual D-type FF (pre, clr)) | P-76 |
| P.5.137 | 74xx75 (4-bit Bistable Latches) | P-76 |
| P.5.138 | 74xx76 (Dual JK FF (pre, clr)) | P-77 |
| P.5.139 | 74xx77 (4-bit Bistable Latches) | P-77 |
| P.5.140 | 74xx78 (Dual JK FF (pre, com clk & clr)) | P-77 |
| P.5.141 | 74xx82 (2-bit Bin Full Adder) | P-78 |
| P.5.142 | 74xx83 (4-bit Bin Full Adder) | P-79 |
| P.5.143 | 74xx85 (4-bit Mag COMP) | P-79 |
| P.5.144 | 74xx86 (Quad 2-In XOR) | P-80 |
| P.5.145 | 74xx90 (Decade Counter) | P-80 |
| P.5.146 | 74xx91 (8-bit Shift Reg) | P-80 |
| P.5.147 | 74xx92 (Divide-by-twelve Counter) | P-81 |
| P.5.148 | 74xx93 (4-bit Binary Counter) | P-82 |

Appendix P Functions (74XX Series)

P.1 Standard TTL



The characteristics of the standard TTL series can be illustrated by the 7400 quad NAND gate IC.

The 74 series uses a nominal supply voltage (V_{OC}) of 5V and can operate reliably over the range 4.75 to 5.25 V. The voltages applied to any input of a standard 74 series IC must never exceed +5.5 V. The maximum negative voltage that can be applied to a TTL input is -0.5 V.

The 74 series IC is designed to operate in ambient temperatures ranging from 0 to 70° C. The guaranteed worst-case DC noise margins for the 74 series are 400 mV.

A standard TTL NAND gate requires an average power of 10 mV.

A standard TTL output can typically drive 10 standard TTL inputs.

P.2 Schottky TTL

The basic circuitry of the standard TTL series forms the central part of several other TTL series, including the Schottky TTL, 74S series.

The Schottky TTL (the 74S series) reduces the storage-time delay by not allowing the transistor to go as deeply into saturation. The 74S series does this by using a Schottky barrier diode connected between the base and the collector of each transistor.

Circuits in the 74S series also use smaller resistor values to help improve switching times. This increases the circuit average power dissipation to about 20 mV. These circuits also use a Darlington pair to provide a shorter output rise time when switching from ON to OFF.

P.3 Low-Power Schottky TTL

The low-power Schottky TTL (the 74LS series) is lower in power and slower in speed than the 74S series. It uses the Schottky-clamped transistor, but with larger resistor values than the 74S series. The larger resistor values reduce the power requirements of the circuit, but increase the switching times.

A NAND gate in the 74LS series typically has an average propagation delay of 9.5 ns and an average power dissipation of 2 mW.

P.4 Tiny Logic

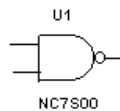

Tiny Logic is a line of single function digital CMOS chips from Fairchild which are intended for application which require only a single gate to complete the design as in the form of glue logic.

P.5 74xx

P.5.1 74xx00 (Quad 2-In NAND)

This device contains four independent 2-input NAND gates.

Logic function:

$$Y = \overline{AB}$$

NAND gate truth table:

| A | B | Y |
|---|---|---|
| 0 | 0 | 1 |
| 1 | 0 | 1 |
| 0 | 1 | 1 |
| 1 | 1 | 0 |

P.5.2 74xx02 (Quad 2-In NOR)

This device contains four independent 2-input NOR gates.

Logic function:

$$Y = \overline{A+B}$$

NOR gate truth table:

| A | B | Y |
|---|---|---|
| 0 | 0 | 1 |
| 1 | 0 | 0 |
| 0 | 1 | 0 |
| 1 | 1 | 0 |

P.5.3 74xx03 (Quad 2-In NAND (Ls-OC))

This device contains four independent 2-input NAND gates. For correct performance, the open collector outputs require pull-up resistors.

Logic function:

$$Y = \overline{AB}$$

NAND gate truth table:

| A | B | Y |
|---|---|---|
| 0 | 0 | 1 |
| 0 | 1 | 1 |
| 1 | 0 | 1 |
| 1 | 1 | 0 |

P.5.4 74xx04 (Hex INVERTER)

This device contains six independent INVERTER gates.

Logic function:

$$Y = \overline{A}$$

INVERTER gate truth table:

| A | Y |
|---|---|
| 1 | 0 |
| 0 | 1 |

P.5.5 74xx05 (Hex INVERTER (OC))

This device contains six independent INVERTER gates. For correct performance, the open collector outputs require pull-up resistors.

Logic function:

$$Y = \bar{A}$$

INVERTER gate truth table:

| A | Y |
|---|---|
| 1 | 0 |
| 0 | 1 |

P.5.6 74xx06 (Hex INVERTER (OC))

This device contains six independent INVERTER gates. For correct performance, the open collector outputs require pull-up resistors.

Logic function:

$$Y = \bar{A}$$

INVERTER gate truth table:

| A | Y |
|---|---|
| 1 | 0 |
| 0 | 1 |

P.5.7 74xx07 (Hex BUFFER (OC))

This device contains six independent BUFFER/non-inverting gates. For correct performance, the open collector outputs require pull-up resistors.

Logic function:

$$Y = \bar{B}$$

BUFFER gate truth table:

| A | Y |
|---|---|
| 0 | 0 |
| 1 | 1 |

P.5.8 74xx08 (Quad 2-In AND)

This device contains four independent 2-input AND gates.

Logic function:

$$Y = \overline{AB}$$

AND gate truth table:

| A | B | Y |
|---|---|---|
| 0 | 0 | 0 |
| 1 | 0 | 0 |
| 0 | 1 | 0 |
| 1 | 1 | 1 |

P.5.9 74xx09 (Quad 2-In AND (OC))

This device contains four independent 2-input AND gates. For correct performance, the open collector outputs require pull-up resistors.

Logic function:

$$Y = \overline{AB}$$

AND gate truth table:

| A | B | Y |
|---|---|---|
| 0 | 0 | 0 |
| 1 | 0 | 0 |
| 0 | 1 | 0 |
| 1 | 1 | 1 |

P.5.10 74xx10 (Tri 3-In NAND)

This device contains three independent 3-input NAND gates.

Logic function:

$$Y = \overline{ABC}$$

NAND gate truth table:

| A | B | C | Y |
|---|---|---|---|
| 0 | 0 | 0 | 1 |
| 1 | 0 | 0 | 1 |
| 0 | 1 | 0 | 1 |
| 1 | 1 | 0 | 1 |
| 0 | 0 | 1 | 1 |
| 1 | 0 | 1 | 1 |
| 0 | 1 | 1 | 1 |
| 1 | 1 | 1 | 0 |

P.5.11 74xx100 (8-Bit Bist Latch)

The 74100 is an 8-bit bistable latch.

8-bit bistable latch truth table:

| INPUTS | | OUTPUTS | |
|--------|---|---------|-----------------|
| D | G | Q | \overline{Q} |
| 0 | 1 | 0 | 1 |
| 1 | 1 | 1 | 0 |
| X | 0 | Q0 | $\overline{Q0}$ |

P.5.12 74xx107 (Dual JK FF(clr))

This device is a positive pulse-triggered flip-flop. It contains two independent J-K flip-flops with individual J-K, clock, and direct clear inputs.

JK flip-flop truth table:

| $\overline{\text{CLR}}$ | CLK | $\overline{\text{J}}$ | K | Q | $\overline{\text{Q}}$ |
|-------------------------|-----|-----------------------|---|--------|-----------------------|
| 0 | X | X | X | 0 | 1 |
| 1 | . | 0 | 0 | Hold | |
| 1 | . | 1 | 0 | 1 | 0 |
| 1 | . | 0 | 1 | 0 | 1 |
| 1 | . | 1 | 1 | Toggle | |

P.5.13 74xx109 (Dual JK FF (+edge, pre, clr))

This device contains two independent J-K positive edge-triggered flip-flops.

JK flip-flop truth table:

| $\overline{\text{PRE}}$ | $\overline{\text{CLR}}$ | CLK | $\overline{\text{J}}$ | K | Q | $\overline{\text{Q}}$ |
|-------------------------|-------------------------|-----|-----------------------|---|--------|-----------------------|
| 0 | 1 | X | X | X | 1 | 0 |
| 1 | 0 | X | X | X | 0 | 1 |
| 0 | 0 | X | X | X | 1 | 1 |
| 1 | 1 | . | 0 | 0 | 0 | 1 |
| 1 | 1 | . | 1 | 0 | Toggle | |
| 1 | 1 | . | 0 | 1 | Hold | |
| 1 | 1 | . | 1 | 1 | 1 | 0 |
| 1 | 1 | 0 | X | X | Hold | |

. = positive edge-triggered

P.5.14 74xx11 (Tri 3-In AND)

This device contains three independent 3-input AND gates.

Logic function:

$$Y = \overline{ABC}$$

AND gate truth table:

| A | B | C | Y |
|---|---|---|---|
| 0 | 0 | 0 | 0 |
| 1 | 0 | 0 | 0 |
| 0 | 1 | 0 | 0 |
| 1 | 1 | 0 | 0 |
| 0 | 0 | 1 | 0 |
| 1 | 0 | 1 | 0 |
| 0 | 1 | 1 | 0 |
| 1 | 1 | 1 | 1 |

P.5.15 74xx112 (Dual JK FF(-edge, pre, clr))

This device contains two independent J-K negative edge-triggered flip-flops.

JK flip-flop truth table:

| $\overline{\text{PRE}}$ | $\overline{\text{CLR}}$ | CLK | $\overline{\text{J}}$ | K | Q | $\overline{\text{Q}}$ |
|-------------------------|-------------------------|-----|-----------------------|---|--------|-----------------------|
| 0 | 1 | X | X | X | 1 | 0 |
| 1 | 0 | X | X | X | 0 | 1 |
| 0 | 0 | X | X | X | 1 | 1 |
| 1 | 1 | , | 0 | 0 | 0 | 1 |
| 1 | 1 | , | 1 | 0 | Toggle | |
| 1 | 1 | , | 0 | 1 | Hold | |
| 1 | 1 | , | 1 | 1 | 1 | 0 |
| 1 | 1 | 0 | X | X | Hold | |

, = negative edge-triggered

P.5.16 74xx113 (Dual JK MS-SLV FF (-edge, pre))

This device contains two independent J-K negative edge-triggered flip-flops.

JK flip-flop truth table:

| $\overline{\text{PRE}}$ | CLK | $\overline{\text{J}}$ | K | Q | $\overline{\text{Q}}$ |
|-------------------------|--------------|-----------------------|------------|------------|-----------------------|
| 0 | X | X | X | 1 | 0 |
| 1 | , | 0 | 0 | Hold | |
| 1 | , | 1 | 0 | 1 | 0 |
| 1 | , | 0 | 1 | 0 | 1 |
| 1 | , | 1 | 1 | Toggle | |
| 1 | 1 | X | X | Hold | |

, = negative edge-triggered

P.5.17 74xx114 (Dual JK FF (-edge, pre, com clk & clr))

This device contains two independent J-K negative edge-triggered flip-flops.

JK flip-flop truth table:

| PRE | CLR | CLK | J | K | Q | $\overline{\text{Q}}$ |
|--------------|--------------|--------------|------------|------------|------------|-----------------------|
| 0 | 0 | X | X | X | 1 | 0 |
| 1 | 0 | X | X | X | 0 | 1 |
| 0 | 0 | X | X | X | 1 | 1 |
| 1 | 1 | , | 0 | 0 | Hold | |
| 1 | 1 | , | 1 | 0 | 1 | 0 |
| 1 | 1 | , | 0 | 1 | 0 | 1 |
| 1 | 1 | , | 1 | 1 | Toggle | |
| 1 | 1 | 1 | X | X | Hold | |

, = negative edge-triggered

P.5.18 74xx116 (Dual 4-bit latches (clr))

This device contains two independent 4-bit latches. Each 4-bit latch has an independent asynchronous clear input and a gated two-input enable circuit.

4-bit latch truth table:

| $\overline{\text{CLR}}$ | INPUTS ENABLE | | | OUTPUT |
|-------------------------|------------------|----|------|--------|
| | C1 | C2 | DATA | Q |
| 1 | 0 | 0 | 0 | 0 |
| 1 | 0 | 0 | 1 | 1 |
| 1 | X | 1 | X | Hold |
| 1 | 1 | X | X | Hold |
| 0 | X | X | X | 0 |

P.5.19 74xx12 (Tri 3-In NAND (OC))

This device contains three independent 3-input NAND gates. For correct performance, the open collector outputs require pull-up resistors.

Logic function:

$$Y = \overline{ABC}$$

NAND gate truth table:

| A | B | C | Y |
|---|---|---|---|
| 0 | 0 | 0 | 1 |
| 1 | 0 | 0 | 1 |
| 0 | 1 | 0 | 1 |
| 1 | 1 | 0 | 1 |
| 0 | 0 | 1 | 1 |
| 1 | 0 | 1 | 1 |
| 0 | 1 | 1 | 1 |
| 1 | 1 | 1 | 0 |

P.5.20 74xx125 (Quad bus BUFFER w/3-state Out)

This device contains four independent BUFFER/non-inverting gates with 3-state outputs.

BUFFER gate truth table:

| \bar{A} | G | Y |
|-----------|---|---|
| 1 | 0 | 0 |
| 0 | 0 | 1 |
| X | 1 | Z |

Z = high impedance

The output of the bus buffer is disabled when G is high.

P.5.21 74xx126 (Quad bus BUFFER w/3-state Out)

This device contains four independent BUFFER/non-inverting gates with 3-state outputs.

BUFFER gate truth table:

| A | G | Y |
|---|---|---|
| 1 | 1 | 1 |
| 0 | 1 | 0 |
| X | 0 | Z |

Z = high impedance

The output of the bus buffer is disabled when G is low.

P.5.22 74xx132 (Quad 2-In NAND (Schmitt))

NAND gate truth table:

| A | B | Y |
|---|---|---|
| 1 | 1 | 0 |
| 0 | X | 1 |
| X | 0 | 1 |

VT+ = 1.8V (at 5 Volt test condition)
 VT- = 0.95V (at 5 Volt test condition)

P.5.23 74xx133 (13-In NAND)

Logic function:

$$Y = \overline{ABCDEFGHIJKLM}$$

NAND gate truth table:

| INPUTS A THRU M | Y |
|----------------------|---|
| All inputs 1 | 0 |
| One or more inputs 0 | 1 |

P.5.24 74xx134 (12-In NAND w/3-state Out)

12-Input NAND with 3-state outputs:

| INPUTS A THRU L | OC | Y |
|----------------------|----|---|
| All inputs 1 | 0 | 0 |
| One or more inputs 0 | 0 | 1 |
| Don't care | 1 | Z |

Z = high impedance (off)

P.5.25 74xx135 (Quad Ex-OR/NOR Gate)

This device can operate as Exclusive-OR gate (C input low) or as Exclusive-NOR gate (C input high).

Exclusive-OR/NOR gate truth table:

| INPUTS | | | OUTPUT |
|--------|---|---|--------|
| A | B | C | Y |
| 0 | 0 | 0 | 0 |
| 0 | 1 | 0 | 1 |
| 1 | 0 | 0 | 1 |
| 1 | 1 | 0 | 0 |
| 0 | 0 | 1 | 1 |
| 0 | 1 | 1 | 0 |
| 1 | 0 | 1 | 0 |
| 1 | 1 | 1 | 1 |

P.5.26 74xx136 (Quad 2-in Exc-OR gate)

This device is a quadruple 2-input exclusive-OR gate with open-collector outputs.

Exclusive-OR gate truth table:

| INPUTS | | OUTPUT |
|--------|---|--------|
| A | B | Y |
| 0 | 0 | 0 |
| 0 | 1 | 1 |
| 1 | 0 | 1 |
| 1 | 1 | 0 |

P.5.27 74xx138 (3-to-8 Dec)

This device decodes one of eight lines dependent on the conditions at the three binary select inputs and the three enable inputs.

3-to-8 decoder/demultiplexer truth table:

| $\overline{G1}$ | G1 | $\overline{G2}$ | SELECT | | | Y0 | Y1 | Y2 | Y3 | Y4 | Y5 | Y6 | Y7 |
|-----------------|----|-----------------|--------|---|---|--------------------------------------------------------|----|----|----|----|----|----|----|
| | | | C | B | A | | | | | | | | |
| X | X | 1 | X | X | X | 1 | 1 | 1 | 1 | 1 | 1 | 1 | 1 |
| X | 0 | X | X | X | X | 1 | 1 | 1 | 1 | 1 | 1 | 1 | 1 |
| 0 | 1 | 0 | 0 | 0 | 0 | 0 | 1 | 1 | 1 | 1 | 1 | 1 | 1 |
| 0 | 1 | 0 | 0 | 0 | 1 | 1 | 0 | 1 | 1 | 1 | 1 | 1 | 1 |
| 0 | 1 | 0 | 0 | 1 | 0 | 1 | 1 | 0 | 1 | 1 | 1 | 1 | 1 |
| 0 | 1 | 0 | 0 | 1 | 1 | 1 | 1 | 1 | 0 | 1 | 1 | 1 | 1 |
| 0 | 1 | 0 | 1 | 0 | 0 | 1 | 1 | 1 | 1 | 0 | 1 | 1 | 1 |
| 0 | 1 | 0 | 1 | 0 | 1 | 1 | 1 | 1 | 1 | 0 | 1 | 1 | 1 |
| 0 | 1 | 0 | 1 | 1 | 0 | 1 | 1 | 1 | 1 | 1 | 0 | 1 | 1 |
| 0 | 1 | 0 | 1 | 1 | 1 | 1 | 1 | 1 | 1 | 1 | 1 | 0 | 1 |
| 1 | 1 | 0 | X | X | X | Output corresponding to stored address 0; all others 1 | | | | | | | |

P.5.28 74xx139 (Dual 2-to-4 Dec/DEMUX)

This decoder/demultiplexer contains two individual two-line to four-line decoders. It features fully buffered inputs, each of which represents only one normalized load to its driving circuit.

2-to-4 decoder/demultiplexer truth table:

| INPUTS | | | OUTPUTS | | | |
|----------------|--------|---|---------|----|----|----|
| ENABLE | SELECT | | Y0 | Y1 | Y2 | Y3 |
| \overline{G} | B | A | | | | |
| 1 | X | X | 1 | 1 | 1 | 1 |
| 0 | 0 | 0 | 0 | 1 | 1 | 1 |
| 0 | 0 | 1 | 1 | 0 | 1 | 1 |
| 0 | 1 | 0 | 1 | 1 | 0 | 1 |
| 0 | 1 | 1 | 1 | 1 | 1 | 0 |

P.5.29 74xx14 (Hex INVERTER (Schmitt))

A key feature of this integrated circuit is its high noise immunity. Due to the Schmitt-trigger action, this device is ideal for circuits that are susceptible to unwanted small signals, such as noise.

INVERTER gate truth table:

| A | Y |
|---|---|
| 0 | 1 |
| 1 | 0 |

The voltage threshold levels are as follows:

VT- = 0.95V (at 5 Volt test condition)
 VT+ = 1.8V (at 5 Volt test condition)

P.5.30 74xx145 (BCD-to-Decimal Dec)

The BCD-to-decimal decoder/driver consists of eight inverters and ten four-input NAND gates. These decoders feature high-performance, n-p-n output transistors designed for use as indicator/relay drivers or as open-collector logic-circuit drivers.

BCD to decimal decoder/driver truth table:

| No. | INPUTS | | | | OUTPUTS | | | | | | | | | | |
|---------|--------|---|---|---|---------|---|---|---|---|---|---|---|---|---|---|
| | D | C | B | A | 0 | 1 | 2 | 3 | 4 | 5 | 6 | 7 | 8 | 9 | |
| 0 | 0 | 0 | 0 | 0 | 0 | 1 | 1 | 1 | 1 | 1 | 1 | 1 | 1 | 1 | 1 |
| 1 | 0 | 0 | 0 | 1 | 1 | 0 | 1 | 1 | 1 | 1 | 1 | 1 | 1 | 1 | 1 |
| 2 | 0 | 0 | 1 | 0 | 1 | 1 | 0 | 1 | 1 | 1 | 1 | 1 | 1 | 1 | 1 |
| 3 | 0 | 0 | 1 | 1 | 1 | 1 | 1 | 0 | 1 | 1 | 1 | 1 | 1 | 1 | 1 |
| 4 | 0 | 1 | 0 | 0 | 1 | 1 | 1 | 1 | 1 | 0 | 1 | 1 | 1 | 1 | 1 |
| 5 | 0 | 1 | 0 | 1 | 1 | 1 | 1 | 1 | 1 | 0 | 1 | 1 | 1 | 1 | 1 |
| 6 | 0 | 1 | 1 | 0 | 1 | 1 | 1 | 1 | 1 | 1 | 0 | 1 | 1 | 1 | 1 |
| 7 | 0 | 1 | 1 | 1 | 1 | 1 | 1 | 1 | 1 | 1 | 1 | 0 | 1 | 1 | 1 |
| 8 | 1 | 0 | 0 | 0 | 1 | 1 | 1 | 1 | 1 | 1 | 1 | 1 | 1 | 0 | 1 |
| 9 | 1 | 0 | 0 | 1 | 1 | 1 | 1 | 1 | 1 | 1 | 1 | 1 | 1 | 1 | 0 |
| INVALID | 1 | 0 | 1 | 0 | 1 | 1 | 1 | 1 | 1 | 1 | 1 | 1 | 1 | 1 | 1 |
| | 1 | 0 | 1 | 1 | 1 | 1 | 1 | 1 | 1 | 1 | 1 | 1 | 1 | 1 | 1 |
| | 1 | 1 | 0 | 0 | 1 | 1 | 1 | 1 | 1 | 1 | 1 | 1 | 1 | 1 | 1 |
| | 1 | 1 | 0 | 1 | 1 | 1 | 1 | 1 | 1 | 1 | 1 | 1 | 1 | 1 | 1 |
| | 1 | 1 | 1 | 0 | 1 | 1 | 1 | 1 | 1 | 1 | 1 | 1 | 1 | 1 | 1 |
| | 1 | 1 | 1 | 1 | 1 | 1 | 1 | 1 | 1 | 1 | 1 | 1 | 1 | 1 | 1 |

P.5.31 74xx147 (10-to-4 Priority Enc)

This TTL encoder features priority decoding of the inputs to ensure that only the highest-order data line is encoded. It encodes nine data lines to four-line (8-4-2-1) BCD.

10I-line to 4-line priority encoder truth table:

| INPUTS | | | | | | | | | OUTPUTS | | | |
|--------|---|---|---|---|---|---|---|---|---------|---|---|---|
| 1 | 2 | 3 | 4 | 5 | 6 | 7 | 8 | 9 | D | C | B | A |
| 1 | 1 | 1 | 1 | 1 | 1 | 1 | 1 | 1 | 1 | 1 | 1 | 1 |
| X | X | X | X | X | X | X | X | 0 | 0 | 1 | 1 | 0 |
| X | X | X | X | X | X | X | 0 | 1 | 0 | 1 | 1 | 1 |
| X | X | X | X | X | X | 0 | 1 | 1 | 1 | 0 | 0 | 0 |
| X | X | X | X | X | 0 | 1 | 1 | 1 | 1 | 0 | 0 | 1 |
| X | X | X | X | 0 | 1 | 1 | 1 | 1 | 1 | 0 | 1 | 0 |
| X | X | X | 0 | 1 | 1 | 1 | 1 | 1 | 1 | 0 | 1 | 1 |
| X | X | 0 | 1 | 1 | 1 | 1 | 1 | 1 | 1 | 1 | 0 | 0 |
| X | 0 | 1 | 1 | 1 | 1 | 1 | 1 | 1 | 1 | 1 | 0 | 1 |
| 0 | 1 | 1 | 1 | 1 | 1 | 1 | 1 | 1 | 1 | 1 | 1 | 0 |

P.5.32 74xx148 (8-to-3 Priority Enc)

This TTL encoder features priority decoding of the inputs to ensure that only the highest-order data line is encoded. It encodes eight data lines to three-line (4-2-1) binary (octal).

8-line to 3-line priority encoder truth table:

| INPUTS | | | | | | | | OUTPUTS | | | | | |
|--------|---|---|---|---|---|---|---|---------|----|----|----|----|----|
| EI | 0 | 1 | 2 | 3 | 4 | 5 | 6 | 7 | A2 | A1 | A0 | GS | EO |
| 1 | X | X | X | X | X | X | X | X | 1 | 1 | 1 | 1 | 1 |
| 0 | 1 | 1 | 1 | 1 | 1 | 1 | 1 | 1 | 1 | 1 | 1 | 1 | 0 |
| 0 | X | X | X | X | X | X | X | 0 | 0 | 0 | 0 | 0 | 1 |
| 0 | X | X | X | X | X | X | 0 | 1 | 0 | 0 | 1 | 0 | 1 |
| 0 | X | X | X | X | X | 0 | 1 | 1 | 0 | 1 | 0 | 0 | 1 |
| 0 | X | X | X | X | 0 | 1 | 1 | 1 | 0 | 1 | 1 | 0 | 1 |
| 0 | X | X | X | 0 | 1 | 1 | 1 | 1 | 1 | 0 | 0 | 0 | 1 |
| 0 | X | X | 0 | 1 | 1 | 1 | 1 | 1 | 1 | 0 | 1 | 0 | 1 |
| 0 | X | 0 | 1 | 1 | 1 | 1 | 1 | 1 | 1 | 1 | 0 | 0 | 1 |
| 0 | 0 | 1 | 1 | 1 | 1 | 1 | 1 | 1 | 1 | 1 | 1 | 0 | 1 |

P.5.33 74xx15 (3 3-Input AND)

Logic function:

$$Y = \overline{ABC}$$

AND gate truth table:

| A | B | C | Y |
|---|---|---|---|
| 1 | 1 | 1 | 1 |
| 0 | X | X | 0 |
| X | 0 | X | 0 |
| X | X | 0 | 0 |

P.5.34 74xx150 (1-of-16 Data Sel/MUX)

This device can select one of sixteen data sources when a 4-bit binary number is applied to the inputs. It is equipped with one enable input and a complementary output.

Truth table:

| INPUTS | | | | OUTPUTS | |
|--------|---|---|---|----------------|------------------|
| D | C | B | A | \overline{G} | W |
| X | X | X | X | 1 | 1 |
| 0 | 0 | 0 | 0 | 0 | $\overline{E0}$ |
| 0 | 0 | 0 | 1 | 0 | $\overline{E1}$ |
| 0 | 0 | 1 | 0 | 0 | $\overline{E2}$ |
| 0 | 0 | 1 | 1 | 0 | $\overline{E3}$ |
| 0 | 1 | 0 | 0 | 0 | $\overline{E4}$ |
| 0 | 1 | 0 | 1 | 0 | $\overline{E5}$ |
| 0 | 1 | 1 | 0 | 0 | $\overline{E6}$ |
| 0 | 1 | 1 | 1 | 0 | $\overline{E7}$ |
| 1 | 0 | 0 | 0 | 0 | $\overline{E8}$ |
| 1 | 0 | 0 | 1 | 0 | $\overline{E9}$ |
| 1 | 0 | 1 | 0 | 0 | $\overline{E10}$ |
| 1 | 0 | 1 | 1 | 0 | $\overline{E11}$ |
| 1 | 1 | 0 | 0 | 0 | $\overline{E12}$ |
| 1 | 1 | 0 | 1 | 0 | $\overline{E13}$ |
| 1 | 1 | 1 | 0 | 0 | $\overline{E14}$ |
| 1 | 1 | 1 | 1 | 1 | $\overline{E15}$ |

P.5.35 74xx151 (1-of-8 Data Sel/MUX)

This data selector/multiplexer contains full on-chip binary decoding to select the desired data source. It selects one of eight data sources and is equipped with one enable input and two complementary outputs.

Data selector/multiplexer truth table:

| SELECT | | | STROBE | OUTPUTS | |
|--------|---|---|----------------|---------|-----------------|
| C | B | A | \overline{G} | Y | W |
| X | X | X | 1 | 0 | 1 |
| 0 | 0 | 0 | 0 | D0 | $\overline{D0}$ |
| 0 | 0 | 1 | 0 | D1 | $\overline{D1}$ |
| 0 | 1 | 0 | 0 | D2 | $\overline{D2}$ |
| 0 | 1 | 1 | 0 | D3 | $\overline{D3}$ |
| 1 | 0 | 0 | 0 | D4 | $\overline{D4}$ |
| 1 | 0 | 1 | 0 | D5 | $\overline{D5}$ |
| 1 | 1 | 0 | 0 | D6 | $\overline{D6}$ |
| 1 | 1 | 1 | 0 | D7 | $\overline{D7}$ |

P.5.36 74xx152 (Data Sel/MUX)

This data selector/multiplexer contains full on-chip binary decoding to select one-of-eight data sources.

Data selector/multiplexer truth table:

| SELECT INPUTS | | | OUTPUT |
|---------------|---|---|-----------------|
| C | B | A | W |
| 0 | 0 | 0 | $\overline{D0}$ |
| 0 | 0 | 1 | $\overline{D1}$ |
| 0 | 1 | 0 | $\overline{D2}$ |
| 0 | 1 | 1 | $\overline{D3}$ |
| 1 | 0 | 0 | $\overline{D4}$ |
| 1 | 0 | 1 | $\overline{D5}$ |
| 1 | 1 | 0 | $\overline{D6}$ |
| 1 | 1 | 1 | $\overline{D7}$ |

P.5.37 74xx153 (Dual 4-to-1 Data Sel/MUX)

This data selector/multiplexor contains inverters and drivers to supply fully complementary, on-chip, binary decoding data selection to the AND-OR gates. Separate strobe inputs are provided for each of the two four-line sections.

Data selector/multiplexer truth table:

| SELECT | | DATA INPUTS | | | | STROBE | OUTPUTS |
|--------|---|-------------|----|----|----|-----------|---------|
| B | A | C0 | C1 | C2 | C3 | \bar{G} | Y |
| X | X | X | X | X | X | 1 | 0 |
| 0 | 0 | 0 | X | X | X | 0 | 0 |
| 0 | 0 | 1 | X | X | X | 0 | 1 |
| 0 | 1 | X | 0 | X | X | 0 | 0 |
| 0 | 1 | X | 1 | X | X | 0 | 1 |
| 1 | 0 | X | X | 0 | X | 0 | 0 |
| 1 | 0 | X | X | 1 | X | 0 | 1 |
| 1 | 1 | X | X | X | 0 | 0 | 0 |
| 1 | 1 | X | X | X | 1 | 0 | 1 |

P.5.38 74xx154 (4-to-16 Dec/DEMUX)

This 4-line-to-16-line decoder uses TTL circuitry to decode four binary-coded inputs into one of sixteen mutually exclusive outputs when both the strobe inputs are low.

4-to-16 decoder/demultiplexer truth table:

| | | INPUTS | | | | OUTPUTS | | | | | | | | | | | | | | | |
|-----------------|-----------------|--------|---|---|---|---------|---|---|---|---|---|---|---|---|---|----|----|----|----|----|----|
| $\overline{G1}$ | $\overline{G2}$ | D | C | B | A | 0 | 1 | 2 | 3 | 4 | 5 | 6 | 7 | 8 | 9 | 10 | 11 | 12 | 13 | 14 | 15 |
| 0 | 0 | 0 | 0 | 0 | 0 | 0 | 1 | 1 | 1 | 1 | 1 | 1 | 1 | 1 | 1 | 1 | 1 | 1 | 1 | 1 | 1 |
| 0 | 0 | 0 | 0 | 0 | 1 | 1 | 0 | 1 | 1 | 1 | 1 | 1 | 1 | 1 | 1 | 1 | 1 | 1 | 1 | 1 | 1 |
| 0 | 0 | 0 | 0 | 1 | 0 | 1 | 1 | 0 | 1 | 1 | 1 | 1 | 1 | 1 | 1 | 1 | 1 | 1 | 1 | 1 | 1 |
| 0 | 0 | 0 | 0 | 1 | 1 | 1 | 1 | 0 | 1 | 1 | 1 | 1 | 1 | 1 | 1 | 1 | 1 | 1 | 1 | 1 | 1 |
| 0 | 0 | 0 | 1 | 0 | 0 | 1 | 1 | 1 | 1 | 0 | 1 | 1 | 1 | 1 | 1 | 1 | 1 | 1 | 1 | 1 | 1 |
| 0 | 0 | 0 | 1 | 0 | 1 | 1 | 1 | 1 | 1 | 0 | 1 | 1 | 1 | 1 | 1 | 1 | 1 | 1 | 1 | 1 | 1 |
| 0 | 0 | 0 | 1 | 1 | 0 | 1 | 1 | 1 | 1 | 1 | 0 | 1 | 1 | 1 | 1 | 1 | 1 | 1 | 1 | 1 | 1 |
| 0 | 0 | 0 | 1 | 1 | 1 | 1 | 1 | 1 | 1 | 1 | 1 | 0 | 1 | 1 | 1 | 1 | 1 | 1 | 1 | 1 | 1 |
| 0 | 0 | 1 | 0 | 0 | 0 | 1 | 1 | 1 | 1 | 1 | 1 | 1 | 1 | 0 | 1 | 1 | 1 | 1 | 1 | 1 | 1 |
| 0 | 0 | 1 | 0 | 0 | 1 | 1 | 1 | 1 | 1 | 1 | 1 | 1 | 1 | 1 | 0 | 1 | 1 | 1 | 1 | 1 | 1 |
| 0 | 0 | 1 | 0 | 1 | 0 | 1 | 1 | 1 | 1 | 1 | 1 | 1 | 1 | 1 | 1 | 0 | 1 | 1 | 1 | 1 | 1 |
| 0 | 0 | 1 | 0 | 1 | 1 | 1 | 1 | 1 | 1 | 1 | 1 | 1 | 1 | 1 | 1 | 1 | 0 | 1 | 1 | 1 | 1 |
| 0 | 0 | 1 | 1 | 0 | 0 | 1 | 1 | 1 | 1 | 1 | 1 | 1 | 1 | 1 | 1 | 1 | 1 | 0 | 1 | 1 | 1 |
| 0 | 0 | 1 | 1 | 0 | 1 | 1 | 1 | 1 | 1 | 1 | 1 | 1 | 1 | 1 | 1 | 1 | 1 | 1 | 0 | 1 | 1 |
| 0 | 0 | 1 | 1 | 1 | 0 | 1 | 1 | 1 | 1 | 1 | 1 | 1 | 1 | 1 | 1 | 1 | 1 | 1 | 1 | 0 | 1 |
| 0 | 0 | 1 | 1 | 1 | 1 | 1 | 1 | 1 | 1 | 1 | 1 | 1 | 1 | 1 | 1 | 1 | 1 | 1 | 1 | 1 | 0 |
| 0 | 1 | X | X | X | X | 1 | 1 | 1 | 1 | 1 | 1 | 1 | 1 | 1 | 1 | 1 | 1 | 1 | 1 | 1 | 1 |
| 1 | 0 | X | X | X | X | 1 | 1 | 1 | 1 | 1 | 1 | 1 | 1 | 1 | 1 | 1 | 1 | 1 | 1 | 1 | 1 |
| 1 | 1 | X | X | X | X | 1 | 1 | 1 | 1 | 1 | 1 | 1 | 1 | 1 | 1 | 1 | 1 | 1 | 1 | 1 | 1 |

P.5.39 74xx155 (Dual 2-to-4 Dec/DEMUX)

This device features a dual 1-line-to-4-line demultiplexer with individual strobes and common binary-address inputs.

Decoder/demultiplexer truth table:

| SELECT | | STROBE | DATA | OUTPUTS | | | |
|--------|---|----------------|------|---------|----|----|----|
| A | B | \overline{G} | C | Y0 | Y1 | Y2 | Y3 |
| X | X | 1 | X | 1 | 1 | 1 | 1 |
| 0 | 0 | 0 | 1 | 0 | 1 | 1 | 1 |
| 0 | 1 | 0 | 1 | 1 | 0 | 1 | 1 |
| 1 | 0 | 0 | 1 | 1 | 1 | 0 | 1 |
| 1 | 1 | 0 | 1 | 1 | 1 | 1 | 0 |
| X | X | X | 0 | 1 | 1 | 1 | 1 |

P.5.40 74xx156 (Dual 2-to-4 Dec/DEMUX (OC))

This device contains two 2-to-4 decoders/demultiplexers.

Decoder/demultiplexer truth table:

| SELECT | | STROBE | DATA | OUTPUTS | | | |
|--------|---|-----------|------|---------|----|----|----|
| A | B | \bar{G} | C | Y0 | Y1 | Y2 | Y3 |
| X | X | 1 | X | 1 | 1 | 1 | 1 |
| 0 | 0 | 0 | 1 | 0 | 1 | 1 | 1 |
| 0 | 1 | 0 | 1 | 1 | 0 | 1 | 1 |
| 1 | 0 | 0 | 1 | 1 | 1 | 0 | 1 |
| 1 | 1 | 0 | 1 | 1 | 1 | 1 | 0 |
| X | X | X | 0 | 1 | 1 | 1 | 1 |

P.5.41 74xx157 (Quad 2-to-1 Data Sel/MUX)

This device contains inverters and drivers to supply full on-chip data selection to the four output gates. It presents true data.

A 4-bit word is selected from one of two sources and is routed to the four outputs.

Data selector/multiplexer truth table:

| STROBE | SELECT | | | OUTPUTS |
|-----------|-------------|---|---|---------|
| \bar{G} | \bar{A}/B | A | B | Y |
| 1 | X | X | X | 0 |
| 0 | 0 | 0 | X | 0 |
| 0 | 0 | 1 | X | 1 |
| 0 | 1 | X | 0 | 0 |
| 0 | 1 | X | 1 | 1 |

P.5.42 74xx158 (Quad 2-to-1 Data Sel/MUX)

This device contains inverters and drivers to supply full on-chip data selection to the four output gates. It presents inverted data to minimize propagation delay time.

A 4-bit word is selected from one of two sources and is routed to the four outputs.

Data selector/multiplexer truth table:

| STROBE \bar{G} | SELECT \bar{A}/B | | | OUTPUT |
|---------------------|-----------------------|---|---|--------|
| | | A | B | Y |
| 1 | X | X | X | 1 |
| 0 | 0 | 0 | X | 1 |
| 0 | 0 | 1 | X | 0 |
| 0 | 1 | X | 0 | 1 |
| 0 | 1 | X | 1 | 0 |

P.5.43 74xx159 (4-to-16 Dec/DEMUX (OC))

This 4-line-to-16-line decoder uses TTL circuitry to decode four binary-coded inputs into one of sixteen mutually exclusive open-collector outputs when both the strobe inputs are low.

The demultiplexing function is performed by using the 4 input lines to address the output line, passing data from one of the strobe inputs with the other strobe input low.

Decoder/demultiplexer truth table:

| | | INPUTS | | | | OUTPUTS | | | | | | | | | | | | | | | |
|------------|------------|--------|---|---|---|---------|---|---|---|---|---|---|---|---|---|----|----|----|----|----|----|
| $\bar{G1}$ | $\bar{G2}$ | D | C | B | A | 0 | 1 | 2 | 3 | 4 | 5 | 6 | 7 | 8 | 9 | 10 | 11 | 12 | 13 | 14 | 15 |
| 0 | 0 | 0 | 0 | 0 | 0 | 0 | 1 | 1 | 1 | 1 | 1 | 1 | 1 | 1 | 1 | 1 | 1 | 1 | 1 | 1 | 1 |
| 0 | 0 | 0 | 0 | 0 | 1 | 1 | 0 | 1 | 1 | 1 | 1 | 1 | 1 | 1 | 1 | 1 | 1 | 1 | 1 | 1 | 1 |
| 0 | 0 | 0 | 0 | 1 | 0 | 1 | 1 | 0 | 1 | 1 | 1 | 1 | 1 | 1 | 1 | 1 | 1 | 1 | 1 | 1 | 1 |
| 0 | 0 | 0 | 0 | 1 | 1 | 1 | 1 | 1 | 0 | 1 | 1 | 1 | 1 | 1 | 1 | 1 | 1 | 1 | 1 | 1 | 1 |
| 0 | 0 | 0 | 1 | 0 | 0 | 1 | 1 | 1 | 1 | 0 | 1 | 1 | 1 | 1 | 1 | 1 | 1 | 1 | 1 | 1 | 1 |
| 0 | 0 | 0 | 1 | 0 | 1 | 1 | 1 | 1 | 1 | 1 | 0 | 1 | 1 | 1 | 1 | 1 | 1 | 1 | 1 | 1 | 1 |
| 0 | 0 | 0 | 1 | 1 | 0 | 1 | 1 | 1 | 1 | 1 | 1 | 0 | 1 | 1 | 1 | 1 | 1 | 1 | 1 | 1 | 1 |
| 0 | 0 | 0 | 1 | 1 | 1 | 1 | 1 | 1 | 1 | 1 | 1 | 1 | 0 | 1 | 1 | 1 | 1 | 1 | 1 | 1 | 1 |
| 0 | 0 | 1 | 0 | 0 | 0 | 1 | 1 | 1 | 1 | 1 | 1 | 1 | 1 | 0 | 1 | 1 | 1 | 1 | 1 | 1 | 1 |
| 0 | 0 | 1 | 0 | 0 | 1 | 1 | 1 | 1 | 1 | 1 | 1 | 1 | 1 | 1 | 0 | 1 | 1 | 1 | 1 | 1 | 1 |
| 0 | 0 | 1 | 0 | 1 | 0 | 1 | 1 | 1 | 1 | 1 | 1 | 1 | 1 | 1 | 1 | 0 | 1 | 1 | 1 | 1 | 1 |
| 0 | 0 | 1 | 0 | 1 | 1 | 1 | 1 | 1 | 1 | 1 | 1 | 1 | 1 | 1 | 1 | 1 | 0 | 1 | 1 | 1 | 1 |
| 0 | 0 | 1 | 1 | 0 | 0 | 1 | 1 | 1 | 1 | 1 | 1 | 1 | 1 | 1 | 1 | 1 | 1 | 0 | 1 | 1 | 1 |
| 0 | 0 | 1 | 1 | 0 | 1 | 1 | 1 | 1 | 1 | 1 | 1 | 1 | 1 | 1 | 1 | 1 | 1 | 1 | 0 | 1 | 1 |
| 0 | 0 | 1 | 1 | 1 | 0 | 1 | 1 | 1 | 1 | 1 | 1 | 1 | 1 | 1 | 1 | 1 | 1 | 1 | 1 | 0 | 1 |
| 0 | 0 | 1 | 1 | 1 | 1 | 1 | 1 | 1 | 1 | 1 | 1 | 1 | 1 | 1 | 1 | 1 | 1 | 1 | 1 | 1 | 0 |
| 0 | 1 | X | X | X | X | 1 | 1 | 1 | 1 | 1 | 1 | 1 | 1 | 1 | 1 | 1 | 1 | 1 | 1 | 1 | 1 |
| 1 | 0 | X | X | X | X | 1 | 1 | 1 | 1 | 1 | 1 | 1 | 1 | 1 | 1 | 1 | 1 | 1 | 1 | 1 | 1 |
| 1 | 1 | X | X | X | X | 1 | 1 | 1 | 1 | 1 | 1 | 1 | 1 | 1 | 1 | 1 | 1 | 1 | 1 | 1 | 1 |

P.5.44 74xx16 (Hex INVERTER (OC))

This device contains six inverters. For correct performance, the open collector outputs require pull-up resistors.

Logic function:

$$Y = \bar{A}$$

INVERTER gate truth table:

| A | Y |
|---|---|
| 1 | 0 |
| 0 | 1 |

P.5.45 74xx160 (Sync 4-bit Decade Counter (clr))

This synchronous, presettable decade counter features an internal carry look-ahead for fast counting.

Decade counter truth table:

| $\overline{\text{MR}}$ | INPUTS | | | | | OUTPUTS | | OPERATING MODE |
|------------------------|--------|-----|-----|------------------------|----|----------------|-----|-------------------|
| | CP | CEP | CET | $\overline{\text{PE}}$ | DN | QN | TC | |
| 0 | X | X | X | X | X | 0 | 0 | Reset (clear) |
| 1 | · | X | X | l | l | 0 | 0 | Parallel load |
| 1 | · | X | X | l | h | 1 | (1) | |
| 1 | · | h | h | h | X | count | (1) | Count |
| 1 | X | l | X | h | X | q _n | (1) | Hold (do nothing) |
| 1 | X | X | l | h | X | q _n | 0 | |

1 = High voltage level

h = High voltage level one setup prior to the low-to-high clock transition

0 = Low voltage level

l = Low voltage level one setup prior to the low-to-high clock transition

q_n = Lower case letters indicate the state of the referenced output prior to the low-to-high clock transition

X = Don't care

- = Low-to-high clock transition
- (1) = The TC output is High when CET is High and the counter is at Terminal Count (HLLH)

P.5.46 74xx161 (Sync 4-bit Bin Counter)

This synchronous, presettable binary counter features an internal carry look-ahead for fast counting.

4-bit bin counter truth table:

| | | INPUTS | | | | OUTPUTS | | | OPERATING |
|------------------------|----|--------|-----|------------------------|----|----------------|-----|----------------------|-----------|
| $\overline{\text{MR}}$ | CP | CET | CET | $\overline{\text{PE}}$ | DN | QN | TC | MODE | |
| 0 | X | X | X | X | X | 0 | 0 | Reset (clear) | |
| 1 | · | X | X | 1 | l | 0 | 0 | Parallel load | |
| 1 | · | X | X | 1 | h | 1 | (1) | | |
| 1 | · | h | h | h | X | count | (1) | Count | |
| 1 | X | l | X | h | X | q _n | (1) | Hold (do nothing) | |
| 1 | X | X | l | h | X | q _n | 0 | | |

- 1 = High voltage level
- h = High voltage level one setup prior to the low-to-high clock transition
- 0 = Low voltage level
- l = Low voltage level one setup prior to the low-to-high clock transition
- q_n = Lower case letters indicate the state of the referenced output prior to the low-to-high clock transition
- X = Don't care
- = Low-to-high clock transition
- (1) = The TC output is High when CET is High and the counter is at Terminal Count (HHHH)

P.5.47 74xx162 (Sync 4-bit Decade Counter)

This synchronous, presettable decade counter features an internal carry look-ahead for fast counting.

Decade counter truth table:

| $\overline{\text{SR}}$ | INPUTS | | | | | OUTPUTS | | OPERATING MODE |
|------------------------|--------|-----|-----|------------------------|----|----------------|-----|-------------------|
| | CP | CEP | CET | $\overline{\text{PE}}$ | DN | QN | TC | |
| 1 | . | X | X | X | X | 0 | 0 | Reset (clear) |
| h | . | X | X | 1 | 1 | 0 | 0 | Parallel load |
| h | . | X | X | 1 | h | 1 | (2) | |
| h | . | h | h | h | X | cou | (2) | Count |
| h | X | 1 | X | h | X | q _n | (2) | Hold (do nothing) |
| h | X | X | 1 | h | X | q _n | 0 | |

- 1 = High voltage level
- h = High voltage level one setup prior to the low-to-high clock transition
- 0 = Low voltage level
- l = Low voltage level one setup prior to the low-to-high clock transition
- q_n = Lower case letters indicate the state of the referenced output prior to the low-to-high clock transition
- X = Don't care
- .
- (2) = The TC output is High when CET is High and the counter is at Terminal Count (HLLH)

P.5.48 74xx163 (Sync 4-bit Binary Counter)

This synchronous, presettable, 4-bit binary counter features an internal carry look-ahead for fast counting.

4-bit counter truth table:

| $\overline{\text{SR}}$ | INPUTS | | | | $\overline{\text{PE}}$ | OUTPUTS | | OPERATING MODE |
|------------------------|--------|-----|-----|----|------------------------|----------------|-----|-------------------|
| | CP | CEP | CET | DN | | QN | TC | |
| 1 | . | X | X | X | X | 0 | 0 | Reset (clear) |
| h | . | X | X | 1 | 1 | 0 | 0 | Parallel load |
| h | . | X | X | 1 | h | 1 | (2) | |
| h | . | h | h | h | X | cou | (2) | Count |
| h | X | 1 | X | h | X | q _n | (2) | Hold (do nothing) |
| h | X | X | 1 | h | X | q _n | 0 | |

- 1 = High voltage level
- h = High voltage level one setup prior to the low-to-high clock transition
- 0 = Low voltage level
- l = Low voltage level one setup prior to the low-to-high clock transition
- q_n = Lower case letters indicate the state of the referenced output prior to the low-to-high clock transition
- X = Don't care
- .
- (2) = The TC output is High when CET is High and the counter is at Terminal Count (HHHH)

P.5.49 74xx164 (8-bit Parallel-Out Serial Shift Reg)

This 8-bit shift register has gated serial inputs and an asynchronous clear.

Shift register truth table:

| Clear | Clk | A | B | QA | QB | QH |
|-------|-----|---|---|-----|-----|-----|
| 0 | X | X | X | 0 | 0 | 0 |
| 1 | 0 | X | X | QA0 | QB0 | QH0 |
| 1 | . | 1 | 1 | 1 | QAn | QGn |
| 1 | . | 0 | X | 0 | QAn | QGn |
| 1 | . | X | 0 | 0 | QAn | QGn |

- = positive edge-triggered
- QA0, QB0, QH0 = the level of QA, QB, QH respectively before the indicated steady state input conditions were established
- QAn, QGn = the level of QA or QG before the most recent positive transition of the clock; indicates one-bit shift.

P.5.50 74xx165 (Parallel-load 8-bit Shift Reg)

This serial shift-register shifts the data in the direction of QA toward QH when clocked. To load the data at the 8-inputs into the device, apply a low level at the shift/load input. This register is equipped with a complementary output at the eighth bit.

Shift register truth table:

| SHIFT/ LOAD | INPUTS | | | | | | | | INTERNAL O/P | | OUTPUTS QH |
|----------------|--------|-----|-----|--------|----------|---|---|---|------------------------|-----|---------------|
| | CLK | INH | CLK | SERIAL | PARALLEL | | | | $\overline{\text{QA}}$ | QB | |
| | | | | | A | B | C | D | | | |
| 0 | X | X | X | X | a | b | c | d | a | b | h |
| 1 | 0 | 0 | 0 | X | X | X | X | X | QA0 | QB0 | QH0 |
| 1 | 0 | · | 1 | X | X | X | X | X | 1 | QAn | QGn |
| 1 | 0 | · | 0 | X | X | X | X | X | 0 | QAn | QGn |
| 1 | 1 | X | X | X | X | X | X | X | QA0 | QB0 | QH0 |

- = transition from low to high
- a,b,c,d = the level of steady state input at A, B, C, or D respectively

P.5.51 74xx166 (Parallel-load 8-bit Shift Reg)

This shift-register is a parallel-in or serial-in, serial out device. It shifts the data in the direction of QA toward QH when clocked. It features an active-low clear input. To load the data at the 8-inputs into the device, apply a low level at the shift/load input.

Shift register truth table:

| CLR | SHIFT/ LOAD | INPUTS | | | | | | INTERNAL OUTPUTS O/P | | | |
|-----|----------------|--------|-----|-----|--------|-------------------------|---|-------------------------|-----------------|-----------------|-----|
| | | CLK | INH | CLK | SERIAL | PARALLEL A through H | | | \overline{QA} | \overline{QB} | QH |
| 0 | X | X | X | X | X | X | X | X | 0 | 0 | 0 |
| 1 | X | 0 | 0 | X | X | X | X | X | QA0 | QB0 | QH0 |
| 1 | 0 | 0 | . | X | A TO H | | | a | b | 1 | |
| 1 | 1 | 0 | . | 1 | X | X | X | X | 1 | QAn | QGn |
| 1 | 1 | 0 | . | 0 | X | X | X | X | 0 | QAn | QGn |
| 1 | X | 1 | . | X | X | X | X | X | QA0 | QB0 | QH0 |

. = transition from low to high
 a,b,c,d = the level of steady state input at A, B, C, or D respectively

P.5.52 74xx169 (Sync 4-bit up/down Binary Counter)

This synchronous presettable 4-bit binary counter has an internal carry look-ahead for cascading in high speed counting applications.

Up/down counter truth table:

| \overline{ENP} | \overline{ENT} | D/U | \overline{CLK} | LOAD | A | \overline{B} | \overline{C} | D | QA | QB | QC | QD | RCO |
|------------------|------------------|-----|------------------|------|---|----------------|----------------|---|------------|-----|-----|-----|-----|
| 0 | 0 | X | X | 0 | X | X | X | X | A | B | C | D | 1* |
| 0 | 0 | 1 | . | 1 | X | X | X | X | Count Down | | | | 1* |
| 0 | 0 | 0 | . | 1 | X | X | X | X | Count Up | | | | 1* |
| 1 | X | X | X | X | X | X | X | X | Qa0 | Qb0 | Qc0 | Qd0 | 1* |
| X | 1 | X | X | X | X | X | X | X | Qa0 | Qb0 | Qc0 | Qd0 | 1* |

1* = during the UP count RCO goes LOW at count 15.
 during the DOWN count RCO goes LOW at count 0.

P.5.53 74xx17 (Hex BUFFER (OC))

This device contains six independent BUFFER/Drivers. For correct performance, the open collector outputs require pull-up resistors.

BUFFER gate truth table:

| \bar{A} | y |
|-----------|-----|
| 0 | 0 |
| 1 | 1 |

P.5.54 74xx173 (4-bit D-type Reg w/3-state Out)

D-type register truth table:

| CLEAR | CLK | DATA ENABLE | | DATA | OUTPUT |
|-------|-----|-------------|------------|------|--------|
| | | $\bar{G1}$ | $\bar{G2}$ | D | Q |
| 1 | X | X | X | X | 0 |
| 0 | 0 | X | X | X | Q0 |
| 0 | . | 1 | X | X | Q0 |
| 0 | . | X | 1 | X | Q0 |
| 0 | . | 0 | 0 | 0 | 0 |
| 0 | . | 0 | 0 | 1 | 1 |

P.5.55 74xx174 (Hex D-type FF (clr))

D-type flip-flop truth table:

| CLEAR | \overline{CLK} | D | Q | \bar{Q} |
|-------|------------------|---|----|-----------------|
| 0 | X | X | 0 | 1 |
| 1 | . | 1 | 1 | 0 |
| 1 | . | 0 | 0 | 1 |
| 1 | 0 | X | Q0 | $\overline{Q0}$ |

P.5.56 74xx175 (Quad D-type FF (clr))

D-type flip-flop truth table:

| CLEAR | $\overline{\text{CLK}}$ | D | Q | Q |
|-------|-------------------------|---|----|-----------------|
| 0 | X | X | 0 | 1 |
| 1 | . | 1 | 1 | 0 |
| 1 | . | 0 | 0 | 1 |
| 1 | 0 | X | Q0 | $\overline{Q0}$ |

P.5.57 74xx180 (9-bit Odd/even Par GEN)

This 9-bit (8 data bits plus 1 parity bit) parity generator/checker features odd/even outputs and control inputs to facilitate operation in either odd- or even-parity applications.

Parity generator/checker truth table:

| INPUTS | | | | OUTPUTS | |
|--------|----|------|---|---------|-----|
| S | OF | H's | | S | S |
| AT | A | THRU | H | EVEN | ODD |
| Even | | | | 1 | 0 |
| Odd | | | | 0 | 1 |
| Even | | | | 0 | 1 |
| Odd | | | | 1 | 0 |
| X | | | | 0 | 0 |
| X | | | | 1 | 1 |

P.5.58 74xx181 (Alu/Function Generator)

ALU/function generator truth table:

| SELECTION | | | | ACTIVE - LOW DATA | | |
|-----------|----|----|----|----------------------|--------------------------------|-----------------------------------|
| S3 | S2 | S1 | S0 | M=H | M=L; ARITHMETIC OPERATIONS | |
| | | | | LOGIC FUNCTIONS | Cn=L (NO CARRY) | Cn=H (WITH CARRY) |
| 0 | 0 | 0 | 0 | $F=\bar{A}$ | F= A MINUS 1 | F= A |
| 0 | 0 | 0 | 1 | $F= \bar{A}\bar{B}$ | F= AB MINUS 1 | F= AB |
| 0 | 0 | 1 | 0 | $F= \bar{A}+\bar{B}$ | F= $\bar{A}\bar{B}$ MINUS 1 | F= $\bar{A}\bar{B}$ |
| 0 | 0 | 1 | 1 | F= 1 | F= MINUS 1 (2's comp) | F= Zero |
| 0 | 1 | 0 | 0 | $F= \bar{A}+\bar{B}$ | F= A PLUS (A+ \bar{B}) | F= A PLUS (A+ \bar{B}) PLUS 1 |
| 0 | 1 | 0 | 1 | $F= \bar{B}$ | F= AB PLUS (A+ \bar{B}) | F= AB PLUS (A+B) PLUS 1 |
| 0 | 1 | 1 | 0 | $F= \bar{A}+\bar{B}$ | F= A MINUS B MINUS 1 | F= A MINUS |
| 0 | 1 | 1 | 1 | $F= A+\bar{B}$ | F= A+ \bar{B} | F= (A+ \bar{B}) PLUS 1 |
| 1 | 0 | 0 | 0 | $F= \bar{A}\bar{B}$ | F= A PLUS (A+B) | F= A PLUS (A+B) PLUS 1 |
| 1 | 0 | 0 | 1 | $F= \bar{A}+\bar{B}$ | F= A PLUS B | F= A PLUS B PLUS |
| 1 | 0 | 1 | 0 | F= B | F= $\bar{A}\bar{B}$ PLUS (A+B) | F= AB PLUS (A+B) PLUS 1 |
| 1 | 0 | 1 | 1 | F= A + B | F= (A + B) | F= (A+B) PLUS 1 |
| 1 | 1 | 0 | 0 | F= 0 | F= A PLUS A | F= A PLUS A PLUS 1 |
| 1 | 1 | 0 | 1 | $F= \bar{A}\bar{B}$ | F= AB PLUS A | F= AB PLUS A PLUS 1 |
| 1 | 1 | 1 | 0 | F= AB | F= $\bar{A}\bar{B}$ PLUS A | F= $\bar{A}\bar{B}$ PLUS A PLUS 1 |
| 1 | 1 | 1 | 1 | F= A | F= A | F= A PLUS 1 |

P.5.59 74xx182 (Look-ahead Carry GEN)

The high-speed, look-ahead carry generator can anticipate a carry across four binary adders or groups of adders. It is cascadable to perform full look-ahead across n-bit adders.

Truth table for \bar{G} output:

| INPUTS | | | | | | | OUTPUT |
|------------------------|------------|------------|------------|------------|------------|------------|-----------|
| $\bar{G}3$ | $\bar{G}2$ | $\bar{G}1$ | $\bar{G}0$ | $\bar{P}3$ | $\bar{P}2$ | $\bar{P}1$ | \bar{G} |
| 0 | X | X | X | X | X | X | 0 |
| X | 0 | X | X | 0 | X | X | 0 |
| X | X | 0 | X | 0 | 0 | X | 0 |
| X | X | X | 0 | 0 | 0 | 0 | 0 |
| All other combinations | | | | | | | 1 |

Truth table for \overline{P} output:

| INPUTS | | | | OUTPUT |
|------------------------|-----------------|-----------------|-----------------|----------------|
| $\overline{P3}$ | $\overline{P2}$ | $\overline{P1}$ | $\overline{P0}$ | \overline{P} |
| 0 | 0 | 0 | 0 | 0 |
| All other combinations | | | | 1 |

Truth table for $\overline{Cn+x}$ output:

| INPUTS | | | OUTPUT |
|------------------------|-----------------|------|-------------------|
| $\overline{G0}$ | $\overline{P0}$ | Cn | $\overline{Cn+x}$ |
| 0 | X | X | 1 |
| X | 0 | 1 | 1 |
| All other combinations | | | 0 |

Truth table for $\overline{Cn+y}$ output:

| INPUTS | | | | | OUTPUT |
|------------------------|-----------------|-----------------|-----------------|------|-------------------|
| $\overline{G1}$ | $\overline{G0}$ | $\overline{P1}$ | $\overline{P0}$ | Cn | $\overline{Cn+y}$ |
| 0 | X | X | X | X | 1 |
| X | 0 | 0 | X | X | 1 |
| X | X | 0 | 0 | 1 | 1 |
| All other combinations | | | | | 0 |

Truth table for $\overline{Cn+z}$ output:

| INPUTS | | | | | | | OUTPUT |
|------------------------|-----------------|-----------------|-----------------|-----------------|-----------------|------|-------------------|
| $\overline{G2}$ | $\overline{G1}$ | $\overline{G0}$ | $\overline{P2}$ | $\overline{P1}$ | $\overline{P0}$ | Cn | $\overline{Cn+z}$ |
| 0 | X | X | X | X | X | X | 1 |
| X | 0 | X | 0 | X | X | X | 1 |
| X | X | 0 | 0 | 0 | X | X | 1 |
| X | X | X | 0 | 0 | 0 | 1 | 1 |
| All other combinations | | | | | | | 0 |

- 1 = High level
- 0 = Low level
- X = Don't care

P.5.60 74xx190 (Sync BCD up/down Counter)

This device is a synchronous, BCD, reversible up/down counter.

Counter TC and \overline{RC} truth table:

| INPUTS | | | TERMINAL COUNT STATE | | | | OUTPUTS | |
|------------------|-----------------|----|----------------------|----|----|----|---------|-----------------|
| $\overline{U/D}$ | \overline{CE} | CP | Q0 | Q1 | Q2 | Q3 | TC | \overline{RC} |
| 1 | 1 | X | 1 | X | X | 1 | 0 | 1 |
| 0 | 1 | X | 1 | X | X | 1 | 1 | 1 |
| 0 | 0 | | 1 | X | X | 1 | 1 | |
| 0 | 1 | X | 0 | 0 | 0 | 0 | 0 | 1 |
| 1 | 1 | X | 0 | 0 | 0 | 0 | 1 | 1 |
| 1 | 0 | | 0 | 0 | 0 | 0 | 1 | |

1 = High voltage level

0 = Low voltage level

X = Don't care

= Low pulse

P.5.61 74xx191 (Sync 4-bit up/down Counter)

This device is a synchronous, 4-bit binary, reversible up/down counter.

Counter TC and \overline{RC} truth table:

| INPUTS | | | TERMINAL COUNT STATE | | | | OUTPUTS | |
|------------------|-----------------|----|----------------------|----|----|----|---------|-----------------|
| $\overline{U/D}$ | \overline{CE} | CP | Q0 | Q1 | Q2 | Q3 | TC | \overline{RC} |
| 1 | 1 | X | 1 | 1 | 1 | 1 | 0 | 1 |
| 0 | 1 | X | 1 | 1 | 1 | 1 | 1 | 1 |
| 0 | 0 | | 1 | 1 | 1 | 1 | 1 | |
| 0 | 1 | X | 0 | 0 | 0 | 0 | 0 | 1 |
| 1 | 1 | X | 0 | 0 | 0 | 0 | 1 | 1 |
| 1 | 0 | | 0 | 0 | 0 | 0 | 1 | |

1 = High voltage level

0 = Low voltage level

X = Don't care

= Low pulse

P.5.62 74xx192 (Sync BCD Up/down Counter)

This device is a synchronous, BCD, reversible up/down counter.

Up/down counter truth table:

| MR | INPUTS | | | | | | | OUTPUTS | | | | OPERATING MODE | | |
|----|-----------------|-----|-----|----|----|----|----|------------|----|----|----|------------------|------------------|---------------|
| | \overline{PL} | CPU | CPD | D0 | D1 | D2 | D3 | Q0 | Q1 | Q2 | Q3 | \overline{TCU} | \overline{TCD} | |
| 1 | X | X | 0 | X | X | X | X | 0 | 0 | 0 | 0 | 1 | 0 | Reset |
| 1 | X | X | 1 | X | X | X | X | 0 | 0 | 0 | 0 | 1 | 1 | |
| 0 | 0 | X | 0 | 0 | 0 | 0 | 0 | 0 | 0 | 0 | 0 | 1 | 0 | Parallel load |
| 0 | 0 | X | 1 | 0 | 0 | 0 | 0 | 0 | 0 | 0 | 0 | 1 | 1 | |
| 0 | 0 | 0 | X | 1 | X | X | 1 | Qn=Dn | | | | 0 | 1 | |
| 0 | 0 | 1 | X | 1 | X | X | 1 | Qn=Dn | | | | 1 | 1 | |
| 0 | 1 | . | 1 | X | X | X | X | Count up | | | | 1^1 | 1 | Count up |
| 0 | 1 | 1 | . | X | X | X | X | Count down | | | | 1 | 1^2 | Count down |

.

1^1 = \overline{TCU} =CPU at terminal count up (HLLH)

1^2 = \overline{TCD} =CPD at terminal count down (LLLL)

P.5.63 74xx193 (Sync 4-bit Bin Up/down Counter)

This device is a synchronous, 4-bit binary, reversible up/down counter.

Up/down counter truth table:

| MR | INPUTS | | | | | | | OUTPUTS | | | | OPERATING MODE | | |
|----|-----------------|-----|-----|----|----|----|----|------------|----|----|----|------------------|------------------|---------------|
| | \overline{PL} | CPU | CPD | D0 | D1 | D2 | D3 | Q0 | Q1 | Q2 | Q3 | \overline{TCU} | \overline{TCD} | |
| 1 | X | X | 0 | X | X | X | X | 0 | 0 | 0 | 0 | 1 | 0 | Reset |
| 1 | X | X | 1 | X | X | X | X | 0 | 0 | 0 | 0 | 1 | 1 | |
| 0 | 0 | X | 0 | 0 | 0 | 0 | 0 | 0 | 0 | 0 | 0 | 1 | 0 | Parallel load |
| 0 | 0 | X | 1 | 0 | 0 | 0 | 0 | 0 | 0 | 0 | 0 | 1 | 1 | |
| 0 | 0 | 0 | X | 1 | 1 | 1 | 1 | 1 | 1 | 1 | 1 | 0 | 1 | |
| 0 | 0 | 1 | X | 1 | 1 | 1 | 1 | 1 | 1 | 1 | 1 | 1 | 1 | |
| 0 | 1 | . | 1 | X | X | X | X | Count up | | | | 1^1 | 1 | Count up |
| 0 | 1 | 1 | . | X | X | X | X | Count down | | | | 1 | 1^2 | Count down |

.

1^1 = \overline{TCU} =CPU at terminal count up (HHHH)

$$1^2 = \overline{TCD=CPD} \text{ at terminal count down (LLLL)}$$

P.5.64 74xx194 (4-bit Bidirect Univ. Shift Reg)

This bidirectional shift register has parallel-inputs, parallel outputs, right-shift and left-shift serial inputs, operating-mode-control inputs, and a direct overriding clear line.

Shift register truth table:

| CLEAR | MODE | | CLK | SERIAL | | PARALLEL | | | | OUTPUTS | | | |
|-------|------|----|-----|--------|-------|----------|---|---|---|---------|-----|-----|-----|
| | S1 | S0 | | LEFT | RIGHT | A | B | C | D | QA | QB | QC | QD |
| 0 | X | X | X | X | X | X | X | X | X | 0 | 0 | 0 | 0 |
| 1 | X | X | 0 | X | X | X | X | X | X | QA0 | QB0 | QC0 | QD0 |
| 1 | 1 | 1 | · | X | X | a | b | c | d | a | b | c | d |
| 1 | 0 | 1 | · | X | 1 | X | X | X | X | 1 | QAn | QBn | QCn |
| 1 | 0 | 1 | · | X | 0 | X | X | X | X | 0 | QAn | QBn | QCn |
| 1 | 1 | 0 | · | 1 | X | X | X | X | X | QBn | QCn | QDn | 1 |
| 1 | 1 | 0 | · | 0 | X | X | X | X | X | QBn | QCn | QDn | 0 |
| 1 | 0 | 0 | X | X | X | X | X | X | X | QA0 | QB0 | QC0 | QD0 |

· = transition from low to high

a, b, c, d = the level of steady state input at inputs A, B, C, or D respectively

QA0, QB0, QC0, QD0 = the level of QA, QB, QC, or QD, respectively, before the indicated steady state input conditions were established

QAn, QBn, QCn, QDn = the level of QA, QB, QC, or QD before the most recent negative transition of the clock

P.5.65 74xx195 (4-bit Parallel-Access Shift Reg)

This 4-bit register has parallel inputs, parallel outputs, J-K serial inputs, shift/load control input, and a direct overriding clear.

Shift register truth table:

| CLEAR | SHIFT /LOAD | CLK | SERIAL | | PARALLEL | | | | OUTPUTS | | | | |
|-------|-------------|-----|--------|-----------|----------|---|---|---|-------------|-----|-----|-----|-------------|
| | | | J | \bar{K} | A | B | C | D | QA | QB | QC | QD | \bar{QD} |
| 0 | X | X | X | X | X | X | X | X | 0 | 0 | 0 | 0 | 1 |
| 1 | 0 | . | X | X | a | b | c | d | a | b | c | d | \bar{d} |
| 1 | 1 | 0 | X | X | X | X | X | X | QA0 | QB0 | QC0 | QD0 | $\bar{QD0}$ |
| 1 | 1 | . | 0 | 1 | X | X | X | X | QA0 | QA0 | QBn | QCn | $\bar{Q}Cn$ |
| 1 | 1 | . | 0 | 0 | X | X | X | X | 0 | QAn | QBn | QCn | $\bar{Q}Cn$ |
| 1 | 1 | . | 1 | 1 | X | X | X | X | 1 | QAn | QBn | QCn | $\bar{Q}Cn$ |
| 1 | 1 | . | 1 | 0 | X | X | X | X | $\bar{Q}An$ | QAn | QBn | QCn | $\bar{Q}Cn$ |

- .
- = transition from low to high
- a, b, c, d = the level of steady state input at inputs A, B, C, or D respectively
- QA0, QB0, QC0, = the level of QA, QB, QC, or QD, respectively, before the indicated steady state input conditions were established
- QD0
- QAn, QBn, QCn = the level of QA, QB, QC before the most recent negative transition of the clock

P.5.66 74xx198 (8-bit Shift Reg (shl/shr ctrl))

This bidirectional register has parallel inputs, parallel outputs, right-shift and left-shift serial inputs, operating-mode-control inputs, and a direct overriding clear line.

Shift register truth table:

| CLEAR | MODE | | CLK | SERIAL | | PARALLEL | OUTPUTS | | | |
|-------|------|----|-----|--------|-------|----------|---------|-----|--------|-----|
| | S1 | S0 | | LEFT | RIGHT | A ... h | QA | QB | ... QG | QH |
| 0 | X | X | X | X | X | X | 0 | 0 | 0 | 0 |
| 1 | X | X | 0 | X | X | X | QA0 | QB0 | QG0 | QH0 |
| 1 | 1 | 1 | . | X | X | a...h | a | b | g | h |
| 1 | 0 | 1 | . | X | 1 | X | 1 | QAn | QFn | QGn |
| 1 | 0 | 1 | . | X | 0 | X | 0 | QAn | QFn | QGn |
| 1 | 1 | 0 | . | 1 | X | X | QBn | QCn | QHn | 1 |
| 1 | 1 | 0 | . | 0 | X | X | QBn | QCn | QHn | 1 |
| 1 | 0 | 0 | X | X | X | X | QA0 | QB0 | QG0 | QH0 |

- = transition from low to high
- a...h = the level of steady state input at inputs A through H respectively
- QA0, QB0, QG0, QH0 = the level of QA, QB, QG, or QH, respectively, before the indicated steady state input conditions were established
- QAn, QBn, etc. = the level of QA, QB etc., respectively, before the most recent negative transition of the clock

P.5.67 74xx199 (8-bit Shift Reg (sh/lD ctrl))

This device contains an 8-bit shift register with shift/load control.

Shift register truth table:

| MODE | | | SERIAL | | | | PARALLEL A...H | OUTPUTS | | |
|-------|-----|--------|--------|---|---|-------|-------------------|-------------|-----|--|
| CLEAR | S/L | CLKINH | CLK | J | K | QA | | QB... QG | QH | |
| 0 | X | X | X | X | X | X | 0 | 0 | 0 | |
| 1 | X | 0 | 0 | X | X | X | QA0 | QB0 | QH0 | |
| 1 | 0 | 0 | · | X | X | a...h | a | b..g | h | |
| 1 | 1 | 0 | · | 0 | 1 | X | QA0 | QA0 | QGn | |
| 1 | 1 | 0 | · | 0 | 0 | X | 0 | QAn | QGn | |
| 1 | 1 | 0 | · | 1 | 1 | X | 1 | QCn | 1 | |
| 1 | 1 | 0 | · | 1 | 0 | X | $\overline{Q}An$ | QAn | QGn | |
| 1 | X | 1 | · | X | X | X | QA0 | QB0 | QH0 | |

- = transition from low level to high level
- a...h = the level of steady state input at inputs A through H respectively
- QA0, QB0, QG0, QH0 = the level of QA, QB, QG, or QH, respectively, before the indicated steady state input conditions were established
- QAn, QBn, etc. = the level of QA, QB etc., respectively, before the most recent negative transition of the clock

P.5.68 74xx20 (Dual 4-In NAND)

This device contains two independent 4-input NAND gates.

Logic function:

$$Y = \overline{ABCD}$$

NAND gate truth table:

| A | B | C | D | Y |
|---|---|---|---|---|
| 1 | 1 | 1 | 1 | 0 |
| 0 | X | X | X | 1 |
| X | 0 | X | X | 1 |
| X | X | 0 | X | 1 |
| X | X | X | 0 | 1 |

P.5.69 74xx21 (Dual 4-In AND)

This device contains two independent 4-input AND gates.

Logic function:

$$Y = \overline{ABCD}$$

AND gate truth table:

| A | B | C | D | Y |
|---|---|---|---|---|
| 1 | 1 | 1 | 1 | 1 |
| 0 | X | X | X | 0 |
| X | 0 | X | X | 0 |
| X | X | 0 | X | 0 |
| X | X | X | 0 | 0 |

P.5.70 74xx22 (Dual 4-In NAND (OC))

This device contains two independent 4-input NAND gates. For correct performance, the open collector outputs require pull-up resistors.

Logic function:

$$Y = \overline{ABCD}$$

NAND gate truth table:

| A | B | C | D | Y |
|---|---|---|---|---|
| 1 | 1 | 1 | 1 | 0 |
| 0 | X | X | X | 1 |
| X | 0 | X | X | 1 |
| X | X | 0 | X | 1 |
| X | X | X | 0 | 1 |

P.5.71 74xx238 (3-to-8 line Dec/DEMUX)

The logic levels at the C B and A inputs select one of the eight lines. G1 is an active-high enable input while G2A and G2B are active-low enable inputs.

3-to-8 decoder/demultiplexer truth table:

| G1 | SELECT | | OUTPUTS | | | | | | | | | | |
|----|------------------|------------------|---------|---|---|----|----|----|----|----|----|----|----|
| | $\overline{G2A}$ | $\overline{G2B}$ | C | B | A | Y0 | Y1 | Y2 | Y3 | Y4 | Y5 | Y6 | Y7 |
| X | 1 | X | X | X | X | 0 | 0 | 0 | 0 | 0 | 0 | 0 | 0 |
| X | X | 1 | X | X | X | 0 | 0 | 0 | 0 | 0 | 0 | 0 | 0 |
| 0 | X | X | X | X | X | 0 | 0 | 0 | 0 | 0 | 0 | 0 | 0 |
| 1 | 0 | 0 | 0 | 0 | 0 | 1 | 0 | 0 | 0 | 0 | 0 | 0 | 0 |
| 1 | 0 | 0 | 0 | 0 | 1 | 0 | 1 | 0 | 0 | 0 | 0 | 0 | 0 |
| 1 | 0 | 0 | 0 | 1 | 0 | 0 | 0 | 1 | 0 | 0 | 0 | 0 | 0 |
| 1 | 0 | 0 | 0 | 1 | 1 | 0 | 0 | 0 | 1 | 0 | 0 | 0 | 0 |
| 1 | 0 | 0 | 1 | 0 | 0 | 0 | 0 | 0 | 0 | 1 | 0 | 0 | 0 |
| 1 | 0 | 0 | 1 | 0 | 1 | 0 | 0 | 0 | 0 | 0 | 1 | 0 | 0 |
| 1 | 0 | 0 | 1 | 1 | 0 | 0 | 0 | 0 | 0 | 0 | 0 | 1 | 0 |
| 1 | 0 | 0 | 1 | 1 | 1 | 0 | 0 | 0 | 0 | 0 | 0 | 0 | 1 |

P.5.72 74xx240 (Octal BUFFER w/3-state Out)

This device has high fan-out, improved fan-in, and 400-mV noise margin.

Octal BUFFER gate truth table:

| \bar{G} | A | Y |
|-----------|---|---|
| 1 | X | Z |
| 0 | 0 | 1 |
| 0 | 1 | 0 |

Z = High impedance (off)

P.5.73 74xx241 (Octal BUFFER w/3-state Out)

This device has high fan-out, improved fan-in, and 400-mV noise margin.

Octal BUFFER gate truth table:

| \bar{G} | INPUTS | | | | OUTPUTS | | | |
|-----------|--------|----|----|----|---------|----|----|----|
| | A1 | A2 | A3 | A4 | Y1 | Y2 | Y3 | Y4 |
| 1 | X | X | X | X | Z | Z | Z | Z |
| 0 | X | X | X | X | A1 | A2 | A3 | A4 |

Z = High impedance (off)

A1, A2... = The level of the respective input

P.5.74 74xx244 (Octal BUFFER w/3-state Out)

This device has high fan-out, improved fan-in, and 400-mV noise margin.

Octal BUFFER gate truth table:

| \bar{G} | INPUTS | | | | OUTPUTS | | | |
|-----------|--------|----|----|----|---------|----|----|----|
| | A1 | A2 | A3 | A4 | Y1 | Y2 | Y3 | Y4 |
| 1 | X | X | X | X | Z | Z | Z | Z |
| 0 | X | X | X | X | A1 | A2 | A3 | A4 |

Z = High impedance (off)

A1, A2... = The level of the respective input

P.5.75 74xx246 (BCD-to-seven segment dec)

The BCD-to-seven-segment decoder/driver features active-low outputs designed for driving indicators directly. It has full ripple-blanking input/output controls and a lamp test input.

BCD-to-seven-segment decoder/driver truth table:

| DECIMAL OR FUNCTION | INPUTS | | | | | | BI/ RBO | OUTPUTS | | | | | | | NOTE |
|---------------------------|--------|-----|---|---|---|---|------------|---------|-----|-----|-----|-----|-----|-----|------|
| | LT | RBI | D | C | B | A | | a | b | c | d | e | f | g | |
| 0 | 1 | 1 | 0 | 0 | 0 | 0 | 1 | ON | ON | ON | ON | ON | ON | OFF | 1 |
| 1 | 1 | X | 0 | 0 | 0 | 1 | 1 | OFF | ON | ON | OFF | OFF | OFF | OFF | |
| 2 | 1 | X | 0 | 0 | 1 | 0 | 1 | ON | ON | OFF | ON | ON | OFF | ON | |
| 3 | 1 | X | 0 | 0 | 1 | 1 | 1 | ON | ON | ON | ON | OFF | OFF | ON | |
| 4 | 1 | X | 0 | 1 | 0 | 0 | 1 | OFF | ON | ON | OFF | OFF | ON | ON | |
| 5 | 1 | X | 0 | 1 | 0 | 1 | 1 | ON | OFF | ON | ON | OFF | ON | ON | |
| 6 | 1 | X | 0 | 1 | 1 | 0 | 1 | ON | OFF | ON | ON | ON | ON | ON | |
| 7 | 1 | X | 0 | 1 | 1 | 1 | 1 | ON | ON | ON | OFF | OFF | OFF | OFF | |
| 8 | 1 | X | 1 | 0 | 0 | 0 | 1 | ON | ON | ON | ON | ON | ON | ON | |
| 9 | 1 | X | 1 | 0 | 0 | 1 | 1 | ON | ON | ON | ON | OFF | ON | ON | |
| 10 | 1 | X | 1 | 0 | 1 | 0 | 1 | OFF | OFF | OFF | ON | ON | OFF | ON | |
| 11 | 1 | X | 1 | 0 | 1 | 1 | 1 | OFF | OFF | ON | ON | OFF | OFF | ON | |
| 12 | 1 | X | 1 | 1 | 0 | 0 | 1 | OFF | ON | OFF | OFF | OFF | ON | ON | |
| 13 | 1 | X | 1 | 1 | 0 | 1 | 1 | ON | OFF | OFF | ON | OFF | ON | ON | |
| 14 | 1 | X | 1 | 1 | 1 | 0 | 1 | OFF | OFF | OFF | ON | ON | ON | ON | |
| 15 | 1 | X | 1 | 1 | 1 | 1 | 1 | OFF | OFF | OFF | OFF | OFF | OFF | OFF | |
| BI | X | X | X | X | X | X | 0 | OFF | OFF | OFF | OFF | OFF | OFF | OFF | 2 |
| RBI | 1 | 0 | 0 | 0 | 0 | 0 | 0 | OFF | OFF | OFF | OFF | OFF | OFF | OFF | 3 |
| LT | 0 | X | X | X | X | X | 1 | ON | ON | ON | ON | ON | ON | ON | 4 |

Notes:

1. The blanking input ($\overline{\text{BI}}$) must be open or held at a high logic level when output functions 0 through 15 are desired. The ripple-blanking input ($\overline{\text{RBI}}$) must be open or high if blanking of a decimal zero is not desired.
2. When a low logic level is applied to the blanking input ($\overline{\text{BI}}$), all segment outputs are off regardless of any other input.
3. When ripple-blanking input ($\overline{\text{RBI}}$) and inputs A, B, C, and D are at a low level with the lamp test input high, all segment outputs go off and the ripple-blanking output (RBO) goes to a low level (response condition).
4. When the blanking input/ripple-blanking output ($\overline{\text{BI/RBO}}$) is open or held high and a low is applied to the lamp-test input, all segment outputs are on.

P.5.76 74xx247 (BCD-to-seven segment dec)

The BCD -to-seven-segment decoder/driver features active-low outputs designed for driving indicators directly. It has full ripple-blanking input/output controls and a lamp test input.

BCD-to-seven-segment decoder/driver truth table:

| DECIMAL OR FUNCTION | INPUTS | | | | | | BI/ RBO | OUTPUTS | | | | | | | NOTE |
|---------------------------|--------|-----|---|---|---|---|------------|---------|-----|-----|-----|-----|-----|-----|------|
| | LT | RBI | D | C | B | A | | a | b | c | d | e | f | g | |
| 0 | 1 | 1 | 0 | 0 | 0 | 0 | 1 | ON | ON | ON | ON | ON | ON | OFF | 1 |
| 1 | 1 | X | 0 | 0 | 0 | 1 | 1 | OFF | ON | ON | OFF | OFF | OFF | OFF | |
| 2 | 1 | X | 0 | 0 | 1 | 0 | 1 | ON | ON | OFF | ON | ON | OFF | ON | |
| 3 | 1 | X | 0 | 0 | 1 | 1 | 1 | ON | ON | ON | ON | OFF | OFF | ON | |
| 4 | 1 | X | 0 | 1 | 0 | 0 | 1 | OFF | ON | ON | OFF | OFF | ON | ON | |
| 5 | 1 | X | 0 | 1 | 0 | 1 | 1 | ON | OFF | ON | ON | OFF | ON | ON | |
| 6 | 1 | X | 0 | 1 | 1 | 0 | 1 | ON | OFF | ON | ON | ON | ON | ON | |
| 7 | 1 | X | 0 | 1 | 1 | 1 | 1 | ON | ON | ON | OFF | OFF | OFF | OFF | |
| 8 | 1 | X | 1 | 0 | 0 | 0 | 1 | ON | ON | ON | ON | ON | ON | ON | |
| 9 | 1 | X | 1 | 0 | 0 | 1 | 1 | ON | ON | ON | ON | OFF | ON | ON | |
| 10 | 1 | X | 1 | 0 | 1 | 0 | 1 | OFF | OFF | OFF | ON | ON | OFF | ON | |
| 11 | 1 | X | 1 | 0 | 1 | 1 | 1 | OFF | OFF | ON | ON | OFF | OFF | ON | |
| 12 | 1 | X | 1 | 1 | 0 | 0 | 1 | OFF | ON | OFF | OFF | OFF | ON | ON | |
| 13 | 1 | X | 1 | 1 | 0 | 1 | 1 | ON | OFF | OFF | ON | OFF | ON | ON | |
| 14 | 1 | X | 1 | 1 | 1 | 0 | 1 | OFF | OFF | OFF | ON | ON | ON | ON | |
| 15 | 1 | X | 1 | 1 | 1 | 1 | 1 | OFF | OFF | OFF | OFF | OFF | OFF | OFF | |
| BI | X | X | X | X | X | X | 0 | OFF | OFF | OFF | OFF | OFF | OFF | OFF | 2 |
| RBI | 1 | 0 | 0 | 0 | 0 | 0 | 0 | OFF | OFF | OFF | OFF | OFF | OFF | OFF | 3 |
| LT | 0 | X | X | X | X | X | 1 | ON | ON | ON | ON | ON | ON | ON | 4 |

Notes:

1. The blanking input ($\overline{\text{BI}}$) must be open or held at a high logic level when output functions 0 through 15 are desired. The ripple-blanking input ($\overline{\text{RBI}}$) must be open or high if blanking of a decimal zero is not desired.
2. When a low logic level is applied to the blanking input ($\overline{\text{BI}}$), all segment outputs are off regardless of any other input.
3. When ripple-blanking input ($\overline{\text{RBI}}$) and inputs A, B, C, and D are at a low level with the lamp test input high, all segment outputs go off and the ripple-blanking output (RBO) goes to a low level (response condition).
4. When the blanking input/ripple-blanking output ($\overline{\text{BI/RBO}}$) is open or held high and a low is applied to the lamp-test input, all segment outputs are on.

P.5.77 74xx248 (BCD-to-seven segment dec)

The BCD -to-seven-segment decoder/driver features active-high outputs for driving lamp buffers. It has full ripple-blanking input/output controls and a lamp test input.

BCD-to-seven-segment decoder/driver truth table:

| DECIMAL OR FUNCTION | INPUTS | | | | | | BI/ RBO | OUTPUTS | | | | | | | NOTE |
|---------------------------|--------|-----|---|---|---|---|------------|---------|---|---|---|---|---|---|------|
| | LT | RBI | D | C | B | A | | a | b | c | d | e | f | g | |
| 0 | 1 | 1 | 0 | 0 | 0 | 0 | 1 | 1 | 1 | 1 | 1 | 1 | 1 | 0 | 1 |
| 1 | 1 | X | 0 | 0 | 0 | 1 | 1 | 0 | 1 | 1 | 0 | 0 | 0 | 0 | 1 |
| 2 | 1 | X | 0 | 0 | 1 | 0 | 1 | 1 | 1 | 0 | 1 | 1 | 0 | 1 | 1 |
| 3 | 1 | X | 0 | 0 | 1 | 1 | 1 | 1 | 1 | 1 | 1 | 0 | 0 | 1 | 1 |
| 4 | 1 | X | 0 | 1 | 0 | 0 | 1 | 0 | 1 | 1 | 0 | 0 | 1 | 1 | 1 |
| 5 | 1 | X | 0 | 1 | 0 | 1 | 1 | 1 | 0 | 1 | 1 | 0 | 1 | 1 | 1 |
| 6 | 1 | X | 0 | 1 | 1 | 0 | 1 | 1 | 0 | 1 | 1 | 1 | 1 | 1 | 1 |
| 7 | 1 | X | 0 | 1 | 1 | 1 | 1 | 1 | 1 | 1 | 0 | 0 | 0 | 0 | 1 |
| 8 | 1 | X | 1 | 0 | 0 | 0 | 1 | 1 | 1 | 1 | 1 | 1 | 1 | 1 | 1 |
| 9 | 1 | X | 1 | 0 | 0 | 1 | 1 | 1 | 1 | 1 | 1 | 0 | 1 | 1 | 1 |
| 10 | 1 | X | 1 | 0 | 1 | 0 | 1 | 0 | 0 | 0 | 1 | 1 | 0 | 1 | 1 |
| 11 | 1 | X | 1 | 0 | 1 | 1 | 1 | 1 | 0 | 0 | 1 | 1 | 0 | 0 | 1 |
| 12 | 1 | X | 1 | 1 | 0 | 0 | 1 | 0 | 1 | 0 | 0 | 0 | 1 | 1 | 1 |
| 13 | 1 | X | 1 | 1 | 0 | 1 | 1 | 1 | 0 | 0 | 1 | 0 | 1 | 1 | 1 |
| 14 | 1 | X | 1 | 1 | 1 | 0 | 1 | 0 | 0 | 0 | 1 | 1 | 1 | 1 | 1 |
| 15 | 1 | X | 1 | 1 | 1 | 1 | 1 | 1 | 0 | 0 | 0 | 0 | 0 | 0 | 0 |
| BI | X | X | X | X | X | X | 0 | 0 | 0 | 0 | 0 | 0 | 0 | 0 | 2 |
| RBI | 1 | 0 | 0 | 0 | 0 | 0 | 0 | 0 | 0 | 0 | 0 | 0 | 0 | 0 | 3 |
| LT | 0 | X | X | X | X | X | 1 | 1 | 1 | 1 | 1 | 1 | 1 | 1 | 4 |

Notes:

1. The blanking input ($\overline{\text{BI}}$) must be open or held at a high logic level when output functions 0 through 15 are desired. The ripple-blanking input ($\overline{\text{RBI}}$) must be open or high if blanking of a decimal zero is not desired.
2. When a low logic level is applied to the blanking input ($\overline{\text{BI}}$), all segment outputs are low regardless of any other input.
3. When ripple-blanking input ($\overline{\text{RBI}}$) and inputs A, B, C, and D are at a low level with the lamp test input high, all segment outputs go low and the ripple-blanking output (RBO) goes to a low level (response condition).
4. When the blanking input/ripple-blanking output ($\overline{\text{BI}}/\overline{\text{RBO}}$) is open or held high and a low is applied to the lamp-test input, all segment outputs are high.

P.5.78 74xx249 (BCD-to-seven segment dec)

The BCD -to-seven-segment decoder/driver features active-high outputs for driving lamp buffers. It has full ripple-blanking input/output controls and a lamp test input.

BCD-to-seven-segment decoder/driver truth table:

| DECIMAL OR FUNCTION | INPUTS | | | | | | BI/RBO | OUTPUTS | | | | | | | NOTE |
|---------------------------|--------|-----|---|---|---|---|--------|---------|---|---|---|---|---|---|------|
| | LT | RBI | D | C | B | A | | a | b | c | d | e | f | g | |
| 0 | 1 | 1 | 0 | 0 | 0 | 0 | 1 | 1 | 1 | 1 | 1 | 1 | 1 | 0 | 1 |
| 1 | 1 | X | 0 | 0 | 0 | 1 | 1 | 0 | 1 | 1 | 0 | 0 | 0 | 0 | 1 |
| 2 | 1 | X | 0 | 0 | 1 | 0 | 1 | 1 | 1 | 0 | 1 | 1 | 0 | 1 | |
| 3 | 1 | X | 0 | 0 | 1 | 1 | 1 | 1 | 1 | 1 | 1 | 0 | 0 | 1 | |
| 4 | 1 | X | 0 | 1 | 0 | 0 | 1 | 0 | 1 | 1 | 0 | 0 | 1 | 1 | |
| 5 | 1 | X | 0 | 1 | 0 | 1 | 1 | 1 | 0 | 1 | 1 | 0 | 1 | 1 | |
| 6 | 1 | X | 0 | 1 | 1 | 0 | 1 | 1 | 0 | 1 | 1 | 1 | 1 | 1 | |
| 7 | 1 | X | 0 | 1 | 1 | 1 | 1 | 1 | 1 | 1 | 0 | 0 | 0 | 0 | 1 |
| 8 | 1 | X | 1 | 0 | 0 | 0 | 1 | 1 | 1 | 1 | 1 | 1 | 1 | 1 | 1 |
| 9 | 1 | X | 1 | 0 | 0 | 1 | 1 | 1 | 1 | 1 | 1 | 0 | 1 | 1 | |
| 10 | 1 | X | 1 | 0 | 1 | 0 | 1 | 0 | 0 | 0 | 1 | 1 | 0 | 1 | |
| 11 | 1 | X | 1 | 0 | 1 | 1 | 1 | 0 | 0 | 1 | 1 | 0 | 0 | 1 | |
| 12 | 1 | X | 1 | 1 | 0 | 0 | 1 | 0 | 1 | 0 | 0 | 0 | 1 | 1 | |
| 13 | 1 | X | 1 | 1 | 0 | 1 | 1 | 1 | 0 | 0 | 1 | 0 | 1 | 1 | |
| 14 | 1 | X | 1 | 1 | 1 | 0 | 1 | 0 | 0 | 0 | 1 | 1 | 1 | 1 | |
| 15 | 1 | X | 1 | 1 | 1 | 1 | 1 | 0 | 0 | 0 | 0 | 0 | 0 | 0 | |
| BI | X | X | X | X | X | X | 0 | 0 | 0 | 0 | 0 | 0 | 0 | 0 | 2 |
| RBI | 1 | 0 | 0 | 0 | 0 | 0 | 0 | 0 | 0 | 0 | 0 | 0 | 0 | 0 | 3 |
| LT | 0 | X | X | X | X | X | 1 | 1 | 1 | 1 | 1 | 1 | 1 | 1 | 4 |

Notes:

1. The blanking input ($\overline{\text{BI}}$) must be open or held at a high logic level when output functions 0 through 15 are desired. The ripple-blanking input ($\overline{\text{RBI}}$) must be open or high if blanking of a decimal zero is not desired.
2. When a low logic level is applied to the blanking input ($\overline{\text{BI}}$), all segment outputs are low regardless of any other input.
3. When ripple-blanking input ($\overline{\text{RBI}}$) and inputs A, B, C, and D are at a low level with the lamp test input high, all segment outputs go low and the ripple-blanking output (RBO) goes to a low level (response condition).
4. When the blanking input/ripple-blanking output ($\overline{\text{BI/RBO}}$) is open or held high and a low is applied to the lamp-test input, all segment outputs are high.

P.5.79 74xx25 (Dual 4-In NOR w/Strobe)

This device contains two independent 4-input NOR gates with strobe.

NOR gate with strobe truth table:

| A | B | C | D | G | Y |
|---|---|---|---|---|---|
| 1 | X | X | X | 1 | 0 |
| X | 1 | X | X | 1 | 0 |
| X | X | 1 | X | 1 | 0 |
| X | X | X | 1 | 1 | 0 |
| 0 | 0 | 0 | 0 | X | 1 |
| X | X | X | X | 0 | 1 |

P.5.80 74xx251 (Data Sel/MUX w/3-state Out)

This device contains full on-chip binary decoding to select one-of-eight data sources and has a strobe-controlled three-state output.

Data selector/multiplexer truth table:

| INPUTS | | | | OUTPUTS | |
|--------|---|---|--------|---------|-----------------|
| SELECT | | | STROBE | Y | W |
| C | B | A | S | | |
| X | X | X | 1 | Z | Z |
| 0 | 0 | 0 | 0 | D0 | $\overline{D0}$ |
| 0 | 0 | 1 | 0 | D1 | $\overline{D1}$ |
| 0 | 1 | 0 | 0 | D2 | $\overline{D2}$ |
| 0 | 1 | 1 | 0 | D3 | $\overline{D3}$ |
| 1 | 0 | 0 | 0 | D4 | $\overline{D4}$ |
| 1 | 0 | 1 | 0 | D5 | $\overline{D5}$ |
| 1 | 1 | 0 | 0 | D6 | $\overline{D6}$ |
| 1 | 1 | 1 | 0 | D7 | $\overline{D7}$ |

Z = high impedance (off)
 D0, D1...D7 = level of the respective D input

P.5.81 74xx253 (Dual 4-to-1 Data Sel/MUX w/3-state Out)

This Schottky-clamped data selector/multiplexer contains inverters and drivers to supply fully complementary on-chip, binary decoding data selection to the AND-OR gates.

Data selector/multiplexer truth table:

| XB | A | C0 | $\overline{C1}$ | C2 | C3 | G | Y |
|-----------|----------|-----------|-----------------------------------|-----------|-----------|----------|----------|
| X | X | X | X | X | X | 1 | Z |
| 0 | 0 | 0 | X | X | X | 0 | 0 |
| 0 | 0 | 1 | X | X | X | 0 | 1 |
| 0 | 1 | X | 0 | X | X | 0 | 0 |
| 0 | 1 | X | 1 | X | X | 0 | 1 |
| 1 | 0 | X | X | 0 | X | 0 | 0 |
| 1 | 0 | X | X | 1 | X | 0 | 1 |
| 1 | 1 | X | X | X | 0 | 0 | 0 |
| 1 | 1 | X | X | X | 1 | 0 | 1 |

Z = High impedance (off)

P.5.82 74xx257 (Quad 2-to-1 line Data Sel/MUX)

This device is designed to multiplex signals from 4-bit data sources to 4-output data lines in bus-organized systems. Its 3-state outputs interface directly with the system bus.

Data selector/multiplexer truth table:

| OUTPUT CONTROL | SELECT | A | B | Y |
|-----------------------|---------------|----------|----------|----------|
| 1 | X | X | X | Z |
| 0 | 0 | 0 | X | 0 |
| 0 | 0 | 1 | X | 1 |
| 0 | 1 | X | 0 | 0 |
| 0 | 1 | X | 1 | 1 |

Z = High impedance (off)

P.5.83 74xx258 (Quad 2-to-1 line Data Sel/MUX)

This device is designed to multiplex signals from 4-bit data sources to 4-output data lines in bus-organized systems. Its 3-state outputs interface directly with the system bus.

Data selector/multiplexer truth table:

| OUTPUT CONTROL | SELECT | A | B | Y |
|----------------|--------|---|---|---|
| 1 | X | X | X | Z |
| 0 | 0 | 0 | X | 0 |
| 0 | 0 | 1 | X | 1 |
| 0 | 1 | X | 0 | 0 |
| 0 | 1 | X | 1 | 1 |

Z = High impedance (off)

P.5.84 74xx259 (8-bit Latch)

This 8-bit addressable latch is a 1-of-8 decoder or demultiplexer with active high outputs. It stores single-line data in eight addressable latches.

8-bit addressable latch truth table:

| INPUTS | | OUTPUT OF ADDRESSED LATCH | EACH OTHER OUTPUT | FUNCTION |
|--------|----------------|---------------------------|-------------------|----------------------|
| CLEAR | \overline{G} | | | |
| 1 | 0 | D | Q_{i0} | Addressable latch |
| 1 | 1 | Q_{i0} | Q_{i0} | Memory |
| 0 | 0 | D | 0 | 8-line demultiplexer |
| 0 | 1 | 0 | 0 | Clear |

P.5.85 74xx26 (Quad 2-In NAND (OC))

This device contains four independent 2-input NAND gates.

Logic function:

$$Y = \overline{ABCD}$$

NAND gate truth table:

| A | B | C | D | Y |
|---|---|---|---|---|
| 1 | 1 | 1 | 1 | 0 |
| 0 | X | X | X | 1 |
| X | 0 | X | X | 1 |
| X | X | 0 | X | 1 |
| X | X | X | 0 | 1 |

P.5.86 74xx266 (Quad 2-In XNOR (OC))

This device contains four independent 2-input EXCLUSIVE-NOR gates.

Logic function:

$$Y = \overline{A \oplus B}$$

Exclusive-NOR gate truth table:

| A | B | Y |
|---|---|---|
| 0 | 0 | 1 |
| 0 | 1 | 0 |
| 1 | 0 | 0 |
| 1 | 1 | 1 |

P.5.87 74xx27 (Tri 3-In NOR)

This device contains three independent 3-input NOR gates.

Logic function:

$$Y = \overline{A+B+C}$$

NOR gate truth table:

| A | B | C | Y |
|---|---|---|---|
| 0 | 0 | 0 | 1 |
| 1 | 0 | 0 | 0 |
| 0 | 1 | 0 | 0 |
| 1 | 1 | 0 | 0 |
| 0 | 0 | 1 | 0 |
| 1 | 0 | 1 | 0 |
| 0 | 1 | 1 | 0 |
| 1 | 1 | 1 | 0 |

P.5.88 74xx273 (Octal D-type FF)

D flip-flop truth table:

| CLEAR | CLK | D | Q |
|-------|-----|---|----|
| 0 | X | X | 0 |
| 1 | . | 1 | 1 |
| 1 | . | 0 | 0 |
| 1 | 0 | X | Q0 |

. = transition from low to high

P.5.89 74xx279 (Quad SR latches)

The RS flip-flop has an undesired operating condition, where 1 levels at both inputs will cause both outputs to go to a 0 level. This undefined condition must be avoided. Circuits involving feedback will lead to a “race condition” where the output will be unpredictable.

RS flip-flop truth table:

| S | R | Q | \bar{Q} | |
|---|---|---|-----------|-------------|
| 0 | 0 | - | - | (no change) |
| 0 | 1 | 0 | 1 | |
| 1 | 0 | 1 | 0 | |
| 1 | 1 | X | X | (undefined) |

P.5.90 74xx28 (Quad 2-In NOR)

This device contains four independent 2-input NOR gates.

Logic function:

$$A = \overline{A+B}$$

NOR gate truth table:

| A | B | Y |
|---|---|---|
| 0 | 0 | 1 |
| 1 | 0 | 0 |
| 0 | 1 | 0 |
| 1 | 1 | 0 |

P.5.91 74xx280 (9-bit odd/even parity generator/checker)

9-bit odd/even parity generator/checker truth table:

| NUMBER OF INPUTS | | | | | Σ - EVEN | Σ - ODD |
|---------------------------|----|----|----|---|-------------|------------|
| A THROUGH I THAT ARE HIGH | | | | | | |
| 0, | 2, | 4, | 6, | 8 | 1 | 0 |
| 1, | 3, | 5, | 7, | 9 | 0 | 1 |

Σ = sigma

P.5.92 74xx283 (4-bit Bin Full Add)

This device performs the addition of two 4-bit binary numbers. It features full internal look-ahead across all four bits generating the carry term in ten nanoseconds typically.

P.5.93 74xx290 (Decade Counter)

This device contains four master-slave flip-flops and additional gating to provide a divide-by-two counter and a three-stage binary counter for which the count cycle length is divide-by-five.

Decade counter truth table:

| COUNT | QD | QC | QB | QA | R0 (1) | R0 (2) | R9 (1) | R9 (2) | QD | QC | QB | QA |
|-------|----|----|----|----|--------|--------|--------|--------|-------|----|----|----|
| 0 | 0 | 0 | 0 | 0 | 1 | 1 | 0 | X | 0 | 0 | 0 | 0 |
| 1 | 0 | 0 | 0 | 1 | 1 | 1 | X | 0 | 0 | 0 | 0 | 0 |
| 2 | 0 | 0 | 1 | 0 | X | X | 1 | 1 | 1 | 0 | 0 | 1 |
| 3 | 0 | 0 | 1 | 1 | X | 0 | X | 0 | COUNT | | | |
| 4 | 0 | 1 | 0 | 0 | 0 | X | 0 | X | COUNT | | | |
| 5 | 0 | 1 | 0 | 1 | 0 | X | X | 0 | COUNT | | | |
| 6 | 0 | 1 | 1 | 0 | X | 0 | 0 | X | COUNT | | | |
| 7 | 0 | 1 | 1 | 1 | | | | | | | | |
| 8 | 1 | 0 | 0 | 0 | | | | | | | | |
| 9 | 1 | 0 | 0 | 1 | | | | | | | | |

P.5.94 74xx293 (4-bit Binary Counter)

This device contains four master-slave flip-flops and additional gating to provide a divide-by-two counter and a three-stage binary counter for which the count cycle length is divide-by-eight.

Counter truth table:

| RESET IN | | OUTPUT | | | |
|------------------|------------------|--------|----|----|----|
| $\overline{Ro1}$ | $\overline{Ro2}$ | Qd | Qc | Qb | Qa |
| 1 | 1 | 0 | 0 | 0 | 0 |
| 0 | X | COUNT | | | |
| X | 0 | COUNT | | | |

P.5.95 74xx298 (Quad 2-In MUX)

This quadruple two-input multiplexer selects one of two 4-bit data sources and stores data synchronously with system clock.

Multiplexer truth table:

| WORD SELECT | CLK | QA | QB | QC | QD |
|----------------|-----|-----|-----|-----|-----|
| 0 | , | a1 | b1 | c1 | d1 |
| 1 | , | a2 | b2 | c2 | d2 |
| X | 1 | QA0 | QB0 | QC0 | QD0 |

, = transition from high to low
 a1, a2, etc. = the level of steady state input at A1, A2, etc.
 QA0, QB0, etc. = the level of QA, QB, etc. entered on the most recent negative transition of the clock input

P.5.96 74xx30 (8-In NAND)

Logic function:

$$Y = \overline{ABCDEFGH}$$

8-input NAND gate truth table:

| INPUTS A THROUGH H | Y |
|----------------------|---|
| All inputs 1 | 0 |
| One or more inputs 0 | 1 |

P.5.97 74xx32 (Quad 2-In OR)

This device contains four independent 2-input OR gates.

Logic function:

$$Y = \overline{A+B}$$

OR gate truth table:

| A | B | Y |
|---|---|---|
| 0 | 0 | 0 |
| 1 | 0 | 1 |
| 0 | 1 | 1 |
| 1 | 1 | 1 |

P.5.98 74xx33 (Quad 2-In NOR (OC))

This device contains four independent 2-input NOR gates. For correct performance, the open collector outputs require pull-up resistors.

Logic function:

$$Y = \overline{A+B}$$

NOR gate truth table:

| A | B | Y |
|---|---|---|
| 0 | 0 | 1 |
| 1 | 0 | 0 |
| 0 | 1 | 0 |
| 1 | 1 | 0 |

P.5.99 74xx350 (4-bit Shifter w/3-state Out)

This device shifts 4-bits of data to 0, 1, 2, or 3 places under control of two select lines.

4-bit shifter truth table:

| INPUTS | | | OUTPUTS | | | |
|-----------------|----|----|---------|-----|-----|----|
| \overline{OE} | S1 | S0 | Y0 | Y1 | Y2 | Y3 |
| 1 | X | X | Z | Z | Z | Z |
| 0 | 0 | 0 | D0 | D1 | D2 | D3 |
| 0 | 0 | 1 | D-1 | D0 | D1 | D2 |
| 0 | 1 | 0 | D-2 | D-1 | D0 | D1 |
| 0 | 1 | 1 | D-3 | D-2 | D-1 | D0 |

Z = High impedance (off)

P.5.10074xx351 (Dual Data Sel/MUX w/3-state Out)

The 74351 device is made up of two 8-line-to-1-line data selectors/multiplexors with full decoding on one monolithic chip.

Dual data selector/multiplexor truth table:

| ENABLE \overline{G} | INPUTS | | | OUTPUTS | |
|--------------------------|--------|---|---|------------------|------------------|
| | C | B | A | 1Y | 2Y |
| 1 | X | X | X | Z | Z |
| 0 | 0 | 0 | 0 | $\overline{1D0}$ | $\overline{2D0}$ |
| 0 | 0 | 0 | 1 | $\overline{1D1}$ | $\overline{2D1}$ |
| 0 | 0 | 1 | 0 | $\overline{1D2}$ | $\overline{2D2}$ |
| 0 | 0 | 1 | 1 | $\overline{1D3}$ | $\overline{2D3}$ |
| 0 | X | 0 | 0 | $\overline{D4}$ | $\overline{D4}$ |
| 0 | X | 0 | 1 | $\overline{D5}$ | $\overline{D5}$ |
| 0 | X | 1 | 0 | $\overline{D6}$ | $\overline{D6}$ |
| 0 | X | 1 | 1 | $\overline{D7}$ | $\overline{D7}$ |

P.5.10174xx352 (Dual 4-to-1 Data Sel/MUX)

This device contains inverters and drivers to supply fully complementary on-chip, binary decoding data selection to the AND-OR-invert gates.

Data selector/multiplexer truth table:

| SELECT | | DATA INPUTS | | | | \overline{G} | Y |
|--------|---|-------------|----|----|----|----------------|---|
| B | A | C0 | C1 | C2 | C3 | | |
| X | X | X | X | X | X | 1 | 1 |
| 0 | 0 | 0 | X | X | X | 0 | 1 |
| 0 | 0 | 1 | X | X | X | 0 | 0 |
| 0 | 1 | X | 0 | X | X | 0 | 1 |
| 0 | 1 | X | 1 | X | X | 0 | 0 |
| 1 | 0 | X | X | 0 | X | 0 | 1 |
| 1 | 0 | X | X | 1 | X | 0 | 0 |
| 1 | 1 | X | X | X | 0 | 0 | 1 |
| 1 | 1 | X | X | X | 1 | 0 | 0 |

P.5.10274xx353 (Dual 4-to-1 Data Sel/MUX w/3-state Out)

This device contains inverters and drivers to supply fully complementary on-chip, binary decoding data selection to the AND-OR-invert gates.

Data selector/multiplexer truth table:

| SELECT | | DATA INPUTS | | | | \bar{G} | Y |
|--------|---|-------------|----|----|----|-----------|---|
| B | A | C0 | C1 | C2 | C3 | | |
| X | X | X | X | X | X | 1 | 1 |
| 0 | 0 | 0 | X | X | X | 0 | 1 |
| 0 | 0 | 1 | X | X | X | 0 | 0 |
| 0 | 1 | X | 0 | X | X | 0 | 1 |
| 0 | 1 | X | 1 | X | X | 0 | 0 |
| 1 | 0 | X | X | 0 | X | 0 | 1 |
| 1 | 0 | X | X | 1 | X | 0 | 0 |
| 1 | 1 | X | X | X | 0 | 0 | 1 |
| 1 | 1 | X | X | X | 1 | 0 | 0 |

P.5.10374xx365 (Hex Buffer/Driver w/3-state)

This device features high fan-out, improved fan-in, and can be used to drive terminated lines down to 133 ohms.

Hex buffer/driver truth table:

| INPUTS | | | OUTPUTS | |
|--------------|--------------|-------|---------|-------------|
| \bar{OE}_0 | \bar{OE}_1 | I_n | Y_n | \bar{Y}_n |
| 0 | 0 | 0 | 0 | 1 |
| 0 | 0 | 1 | 1 | 0 |
| X | 1 | X | Z | Z |
| 1 | X | X | Z | Z |

- 1 = High voltage level
- 0 = Low voltage level
- X = Don't care
- Z = high impedance "off" state

P.5.10474xx366 (Hex Inverter Buffer/Driver w/3-state)

This device is a 3-state Hex inverter buffer/driver.

Hex inverter buffer/driver truth table:

| INPUTS | | | OUTPUTS | |
|-------------------|-------------------|-------|---------|------------------|
| \overline{OE}_0 | \overline{OE}_1 | I_n | Y_n | \overline{Y}_n |
| 0 | 0 | 0 | 0 | 1 |
| 0 | 0 | 1 | 1 | 0 |
| X | 1 | X | Z | Z |
| 1 | X | X | Z | Z |

- 1 = High voltage level
- 0 = Low voltage level
- X = Don't care
- Z = High impedance "off" state

P.5.10574xx367 (Hex Buffer/Driver w/3-state)

This device features high fan-out, improved fan-in, and can be used to drive terminated lines down to 133 ohms.

Hex buffer/driver truth table:

| INPUTS | | OUTPUTS | |
|-------------------|-------|---------|------------------|
| \overline{OE}_n | I_n | Y_n | \overline{Y}_n |
| 0 | 0 | 0 | 1 |
| 0 | 1 | 1 | 0 |
| 1 | X | Z | Z |

- 1 = High voltage level
- 0 = Low voltage level
- X = Don't care
- Z = High impedance "off" state

P.5.10674xx368 (Hex Inverter Buffer/Driver w/3-state)

This device is a 3-state hex inverter buffer/driver.

Hex inverter buffer/driver truth table:

| INPUTS | | OUTPUTS | |
|-------------------|-------|---------|------------------|
| \overline{OE}_n | I_n | Y_n | \overline{Y}_n |
| 0 | 0 | 0 | 1 |
| 0 | 1 | 1 | 0 |
| 1 | X | Z | Z |

1 = High voltage level

0 = Low voltage level

X = Don't care

Z = High impedance "off" state

P.5.10774xx37 (Quad 2-In NAND)

This device contains four independent 2-input NAND gates.

Logic function:

$$Y = \overline{AB}$$

NAND gate truth table:

| A | B | Y |
|---|---|---|
| 0 | 0 | 1 |
| 1 | 0 | 1 |
| 0 | 1 | 1 |
| 1 | 1 | 0 |

P.5.10874xx373 (Octal D-type Transparent Latches)

This 8-bit register features three-state bus-driving outputs and transparent D-type latches.
D-latch and flip-flop truth table:

| OUTPUT | ENABLE | | OUTPUT |
|--------|--------|---|--------|
| ENABLE | LATCH | D | |
| 0 | 1 | 1 | 1 |
| 0 | 1 | 0 | 0 |
| 0 | 0 | X | Q0 |
| 1 | X | X | Z |

Z = High impedance (off)

P.5.10974xx374 (Octal D-type FF (+edge))

This 8-bit register features three-state bus-driving outputs and transparent D-type flip-flops.
D-latch and flip-flop truth table:

| OUTPUT | ENABLE | | OUTPUT |
|--------|--------|---|--------|
| ENABLE | LATCH | D | |
| 0 | . | 1 | 1 |
| 0 | . | 0 | 0 |
| 0 | 0 | X | Q0 |
| 1 | X | X | Z |

Z = High impedance (off)

. = Transition from low to high

P.5.11074xx375 (4-bit Bistable Latches)

This device features outputs from a 4-bit latch.

Bistable latch truth table:

| D | C | Q | \bar{Q} |
|---|---|----|------------|
| 0 | 1 | 0 | 1 |
| 1 | 1 | 1 | 0 |
| X | 0 | Q0 | $\bar{Q}0$ |

P.5.111 74xx377 (Octal D-type FF w/en)

This device contains eight flip-flops with single-rail outputs.

D-type flip-flop truth table:

| \bar{G} | CLK | \overline{DATA} | Q | \bar{Q} |
|-----------|-----|-------------------|----|------------|
| 1 | X | X | Q0 | $\bar{Q}0$ |
| 0 | . | 1 | 1 | 0 |
| 0 | . | 0 | 0 | 1 |
| X | 0 | X | Q0 | $\bar{Q}0$ |

P.5.11274xx378 (Hex D-type FF w/en)

This device contains six flip-flops with single-rail outputs.

D-type flip-flop truth table:

| \bar{G} | CLK | \overline{DATA} | Q | \bar{Q} |
|-----------|-----|-------------------|----|------------|
| 1 | X | X | Q0 | $\bar{Q}0$ |
| 0 | . | 1 | 1 | 0 |
| 0 | . | 0 | 0 | 1 |
| X | 0 | X | Q0 | $\bar{Q}0$ |

P.5.113 74xx379 (Quad D-type FF w/en)

This device contains four flip-flops with double-rail outputs.

D-type flip-flop truth table:

| INPUTS | | | OUTPUTS | |
|-----------|-----|------|---------|------------|
| \bar{G} | CLK | DATA | Q | \bar{Q} |
| 1 | X | X | Q0 | $\bar{Q}0$ |
| 0 | . | 1 | 1 | 0 |
| 0 | . | 0 | 0 | 1 |
| X | 0 | X | Q0 | $\bar{Q}0$ |

P.5.114 74xx38 (Quad 2-In NAND (OC))

This device contains four independent 2-input NAND gates. For correct performance, the open collector outputs require pull-up resistors.

Logic function:

$$Y = \overline{AB}$$

NAND gate truth table:

| A | B | Y |
|---|---|---|
| 0 | 0 | 1 |
| 1 | 0 | 1 |
| 0 | 1 | 1 |
| 1 | 1 | 0 |

P.5.115 74xx39 (Quad 2-In NAND (OC))

This device contains four independent 2-input NAND gates. For correct performance, the open collector outputs require pull-up resistors.

Logic function:

$$Y = \overline{AB}$$

NAND gate truth table:

| A | B | Y |
|---|---|---|
| 0 | 0 | 1 |
| 1 | 0 | 1 |
| 0 | 1 | 1 |
| 1 | 1 | 0 |

P.5.11674xx390 (Dual Div-by-2, Div-by-5 Counter)

The 74390 device incorporates dual divide-by-two and divide-by-five counters.

BCD count sequence truth table:

| COUNT | OUTPUT | | | |
|-------|--------|----|----|----|
| | QD | QC | QB | QA |
| 0 | 0 | 0 | 0 | 0 |
| 1 | 0 | 0 | 0 | 1 |
| 2 | 0 | 0 | 1 | 0 |
| 3 | 0 | 0 | 1 | 1 |
| 4 | 0 | 1 | 0 | 0 |
| 5 | 0 | 1 | 0 | 1 |
| 6 | 0 | 1 | 1 | 0 |
| 7 | 0 | 1 | 1 | 1 |
| 8 | 1 | 0 | 0 | 0 |
| 9 | 1 | 0 | 0 | 1 |

Notes:

Output QA is connected to input B for BCD count.

Bi-quinary truth table:

| COUNT | OUTPUT | | | |
|-------|--------|----|----|----|
| | QA | QD | QC | QB |
| 0 | 0 | 0 | 0 | 0 |
| 1 | 0 | 0 | 0 | 1 |
| 2 | 0 | 0 | 1 | 0 |
| 3 | 0 | 0 | 1 | 1 |
| 4 | 0 | 1 | 0 | 0 |
| 5 | 1 | 0 | 0 | 0 |
| 6 | 1 | 0 | 0 | 1 |
| 7 | 1 | 0 | 1 | 0 |
| 8 | 1 | 0 | 1 | 1 |
| 9 | 1 | 1 | 0 | 0 |

Notes:

Output QD is connected to input A for bi-quinary.

P.5.11774xx393 (Dual 4-bit Binary Counter)

This device features an independent active-high clear and clock input for each counter. The 74393 is ideal for circuits that require two independent counters.

The 74393 counts from 0 to 15 in binary on every positive transition (low to high) of the clock pulse.

Count sequence truth table:

| COUNT | OUTPUT | | | |
|-------|--------|----|----|----|
| | QD | QC | QB | QA |
| 0 | 0 | 0 | 0 | 0 |
| 1 | 0 | 0 | 0 | 1 |
| 2 | 0 | 0 | 1 | 0 |
| 3 | 0 | 0 | 1 | 1 |
| 4 | 0 | 1 | 0 | 0 |
| 5 | 0 | 1 | 0 | 1 |
| 6 | 0 | 1 | 1 | 0 |
| 7 | 0 | 1 | 1 | 1 |
| 8 | 1 | 0 | 0 | 0 |
| 9 | 1 | 0 | 0 | 1 |
| 10 | 1 | 0 | 1 | 0 |
| 11 | 1 | 0 | 1 | 1 |
| 12 | 1 | 1 | 0 | 0 |
| 13 | 1 | 1 | 0 | 1 |
| 14 | 1 | 1 | 1 | 0 |
| 15 | 1 | 1 | 1 | 1 |

P.5.11874xx395 (4-bit Cascadable Shift Reg w/3-state Out)

This device is a 4-bit shift register with 3-state outputs. It features parallel-in and parallel out registers.

4-bit shift register truth table:

| \overline{OC} | \overline{CLR} | \overline{LD}/SH | CLK | SER | A | B | C | D | QA | QB | QC | QD | \overline{QD} |
|-----------------|------------------|--------------------|-----|-----|---|---|---|---|-----------|----|----|----|-----------------|
| 0 | X | X | X | X | X | X | X | X | Z | Z | Z | Z | \overline{QD} |
| 1 | 0 | X | X | X | X | X | X | X | 0 | 0 | 0 | 0 | 0 |
| 1 | 1 | 1 | 1 | X | X | X | X | X | NO CHANGE | | | | |
| 1 | 1 | 1 | , | X | A | B | C | D | QA | QB | QC | QD | QD |
| 1 | 1 | 0 | 1 | X | X | X | X | X | NO CHANGE | | | | |
| 1 | 1 | 0 | , | 1 | X | X | X | X | 1 | QA | QB | QC | QC |
| 1 | 1 | 0 | , | 0 | X | X | X | X | 0 | QA | QB | QC | QC |

P.5.11974xx40 (Dual 4-In NAND)

This device contains two independent 4-input NAND gate.

Logic function:

$$Y = \overline{ABCD}$$

NAND gate truth table:

| INPUTS | | | | OUTPUT |
|--------|---|---|---|--------|
| A | B | C | D | Y |
| 1 | 1 | 1 | 1 | 0 |
| 0 | X | X | X | 1 |
| X | 0 | X | X | 1 |
| X | X | 0 | X | 1 |
| X | X | X | 0 | 1 |

P.5.12074xx42 (4-BCD to 10-Decimal Dec)

This BCD-to-decimal decoder consists of eight inverters and ten four-input NAND gates.

4-line to 10-line decimal decoder truth table:

| No. | BCD INPUT | | | | DECIMAL OUTPUT | | | | | | | | | |
|---------|-----------|---|---|---|----------------|---|---|---|---|---|---|---|---|---|
| | D | C | B | A | 0 | 1 | 2 | 3 | 4 | 5 | 6 | 7 | 8 | 9 |
| 0 | 0 | 0 | 0 | 0 | 0 | 1 | 1 | 1 | 1 | 1 | 1 | 1 | 1 | 1 |
| 1 | 0 | 0 | 0 | 1 | 1 | 0 | 1 | 1 | 1 | 1 | 1 | 1 | 1 | 1 |
| 2 | 0 | 0 | 1 | 0 | 1 | 1 | 0 | 1 | 1 | 1 | 1 | 1 | 1 | 1 |
| 3 | 0 | 0 | 1 | 1 | 1 | 1 | 1 | 0 | 1 | 1 | 1 | 1 | 1 | 1 |
| 4 | 0 | 1 | 0 | 0 | 1 | 1 | 1 | 1 | 0 | 1 | 1 | 1 | 1 | 1 |
| 5 | 0 | 1 | 0 | 1 | 1 | 1 | 1 | 1 | 1 | 0 | 1 | 1 | 1 | 1 |
| 6 | 0 | 1 | 1 | 0 | 1 | 1 | 1 | 1 | 1 | 1 | 0 | 1 | 1 | 1 |
| 7 | 0 | 1 | 1 | 1 | 1 | 1 | 1 | 1 | 1 | 1 | 1 | 0 | 1 | 1 |
| 8 | 1 | 0 | 0 | 0 | 1 | 1 | 1 | 1 | 1 | 1 | 1 | 1 | 0 | 1 |
| 9 | 1 | 0 | 0 | 1 | 1 | 1 | 1 | 1 | 1 | 1 | 1 | 1 | 1 | 0 |
| INVALID | 1 | 0 | 1 | 0 | 1 | 1 | 1 | 1 | 1 | 1 | 1 | 1 | 1 | 1 |
| | 1 | 0 | 1 | 1 | 1 | 1 | 1 | 1 | 1 | 1 | 1 | 1 | 1 | 1 |
| | 1 | 1 | 0 | 0 | 1 | 1 | 1 | 1 | 1 | 1 | 1 | 1 | 1 | 1 |
| | 1 | 1 | 0 | 1 | 1 | 1 | 1 | 1 | 1 | 1 | 1 | 1 | 1 | 1 |
| | 1 | 1 | 1 | 0 | 1 | 1 | 1 | 1 | 1 | 1 | 1 | 1 | 1 | 1 |
| | 1 | 1 | 1 | 1 | 0 | 1 | 1 | 1 | 1 | 1 | 1 | 1 | 1 | 1 |
| | 1 | 1 | 1 | 1 | 1 | 1 | 1 | 1 | 1 | 1 | 1 | 1 | 1 | 1 |

P.5.12174xx43 (Exc-3-to-Decimal Dec)

This excess-3-to-decimal decoder consists of eight inverters and ten four-input NAND gates.

Excess-3-to-decimal decoder truth table:

| No. | EXCESS-3- INPUT | | | | DECIMAL OUTPUT | | | | | | | | | |
|---------|-----------------|---|---|---|----------------|---|---|---|---|---|---|---|---|---|
| | D | C | B | A | 0 | 1 | 2 | 3 | 4 | 5 | 6 | 7 | 8 | 9 |
| 0 | 0 | 0 | 1 | 1 | 0 | 1 | 1 | 1 | 1 | 1 | 1 | 1 | 1 | 1 |
| 1 | 0 | 1 | 0 | 0 | 1 | 0 | 1 | 1 | 1 | 1 | 1 | 1 | 1 | 1 |
| 2 | 0 | 1 | 0 | 1 | 1 | 1 | 0 | 1 | 1 | 1 | 1 | 1 | 1 | 1 |
| 3 | 0 | 1 | 1 | 0 | 1 | 1 | 1 | 0 | 1 | 1 | 1 | 1 | 1 | 1 |
| 4 | 0 | 1 | 1 | 1 | 1 | 1 | 1 | 1 | 0 | 1 | 1 | 1 | 1 | 1 |
| 5 | 1 | 0 | 0 | 0 | 1 | 1 | 1 | 1 | 1 | 0 | 1 | 1 | 1 | 1 |
| 6 | 1 | 0 | 0 | 1 | 1 | 1 | 1 | 1 | 1 | 1 | 0 | 1 | 1 | 1 |
| 7 | 1 | 0 | 1 | 0 | 1 | 1 | 1 | 1 | 1 | 1 | 1 | 0 | 1 | 1 |
| 8 | 1 | 0 | 1 | 1 | 1 | 1 | 1 | 1 | 1 | 1 | 1 | 1 | 0 | 1 |
| 9 | 1 | 1 | 0 | 0 | 1 | 1 | 1 | 1 | 1 | 1 | 1 | 1 | 1 | 0 |
| INVALID | 1 | 1 | 0 | 1 | 1 | 1 | 1 | 1 | 1 | 1 | 1 | 1 | 1 | 1 |
| | 1 | 1 | 1 | 0 | 1 | 1 | 1 | 1 | 1 | 1 | 1 | 1 | 1 | 1 |
| | 1 | 1 | 1 | 1 | 0 | 1 | 1 | 1 | 1 | 1 | 1 | 1 | 1 | 1 |
| | 1 | 1 | 1 | 1 | 1 | 1 | 1 | 1 | 1 | 1 | 1 | 1 | 1 | 1 |
| | 0 | 0 | 0 | 0 | 0 | 1 | 1 | 1 | 1 | 1 | 1 | 1 | 1 | 1 |
| | 0 | 0 | 0 | 1 | 1 | 1 | 1 | 1 | 1 | 1 | 1 | 1 | 1 | 1 |
| | 0 | 0 | 1 | 0 | 1 | 1 | 1 | 1 | 1 | 1 | 1 | 1 | 1 | 1 |

P.5.12274xx44 (Exc-3-Gray-to-Decimal Dec)

This excess-3-gray-to-decimal decoder consists of eight inverters and ten four-input NAND gates.

Excess-3-gray-to-decimal decoder truth table:

| No. | EXCESS-3-GRAY INPUT | | | | DECIMAL OUTPUT | | | | | | | | | |
|---------|------------------------|---|---|---|----------------|---|---|---|---|---|---|---|---|---|
| | D | C | B | A | 0 | 1 | 2 | 3 | 4 | 5 | 6 | 7 | 8 | 9 |
| 0 | 0 | 0 | 1 | 0 | 0 | 1 | 1 | 1 | 1 | 1 | 1 | 1 | 1 | 1 |
| 1 | 0 | 1 | 1 | 0 | 1 | 0 | 1 | 1 | 1 | 1 | 1 | 1 | 1 | 1 |
| 2 | 0 | 1 | 1 | 1 | 1 | 1 | 0 | 1 | 1 | 1 | 1 | 1 | 1 | 1 |
| 3 | 0 | 1 | 0 | 1 | 1 | 1 | 1 | 0 | 1 | 1 | 1 | 1 | 1 | 1 |
| 4 | 0 | 1 | 0 | 0 | 1 | 1 | 1 | 1 | 0 | 1 | 1 | 1 | 1 | 1 |
| 5 | 1 | 1 | 0 | 0 | 1 | 1 | 1 | 1 | 1 | 0 | 1 | 1 | 1 | 1 |
| 6 | 1 | 1 | 0 | 1 | 1 | 1 | 1 | 1 | 1 | 1 | 0 | 1 | 1 | 1 |
| 7 | 1 | 1 | 1 | 1 | 1 | 1 | 1 | 1 | 1 | 1 | 1 | 0 | 1 | 1 |
| 8 | 1 | 1 | 1 | 0 | 1 | 1 | 1 | 1 | 1 | 1 | 1 | 1 | 0 | 1 |
| 9 | 1 | 0 | 1 | 0 | 1 | 1 | 1 | 1 | 1 | 1 | 1 | 1 | 1 | 0 |
| INVALID | 1 | 0 | 1 | 1 | 1 | 1 | 1 | 1 | 1 | 1 | 1 | 1 | 1 | 1 |
| | 1 | 0 | 0 | 1 | 1 | 1 | 1 | 1 | 1 | 1 | 1 | 1 | 1 | 1 |
| | 1 | 0 | 0 | 0 | 1 | 1 | 1 | 1 | 1 | 1 | 1 | 1 | 1 | 1 |
| | 0 | 0 | 0 | 0 | 1 | 1 | 1 | 1 | 1 | 1 | 1 | 1 | 1 | 1 |
| | 0 | 0 | 0 | 1 | 1 | 1 | 1 | 1 | 1 | 1 | 1 | 1 | 1 | 1 |
| | 0 | 0 | 1 | 1 | 1 | 1 | 1 | 1 | 1 | 1 | 1 | 1 | 1 | 1 |
| | 0 | 0 | 1 | 0 | 1 | 1 | 1 | 1 | 1 | 1 | 1 | 1 | 1 | 1 |

P.5.12374xx445 (BCD-to-Decimal Dec)

This BCD-to-decimal decoder consists of eight inverters and ten four-input NAND gates.

BCD-to-decimal truth table:

| No. | INPUTS | | | | OUTPUTS | | | | | | | | | |
|---------|--------|---|---|---|---------|---|---|---|---|---|---|---|---|---|
| | D | C | B | A | 0 | 1 | 2 | 3 | 4 | 5 | 6 | 7 | 8 | 9 |
| 0 | 0 | 0 | 0 | 0 | 0 | 1 | 1 | 1 | 1 | 1 | 1 | 1 | 1 | 1 |
| 1 | 0 | 0 | 0 | 1 | 1 | 0 | 1 | 1 | 1 | 1 | 1 | 1 | 1 | 1 |
| 2 | 0 | 0 | 1 | 0 | 1 | 1 | 0 | 1 | 1 | 1 | 1 | 1 | 1 | 1 |
| 3 | 0 | 0 | 1 | 1 | 1 | 1 | 1 | 0 | 1 | 1 | 1 | 1 | 1 | 1 |
| 4 | 0 | 1 | 0 | 0 | 1 | 1 | 1 | 1 | 0 | 1 | 1 | 1 | 1 | 1 |
| 5 | 0 | 1 | 0 | 1 | 1 | 1 | 1 | 1 | 1 | 0 | 1 | 1 | 1 | 1 |
| 6 | 0 | 1 | 1 | 0 | 1 | 1 | 1 | 1 | 1 | 1 | 0 | 1 | 1 | 1 |
| 7 | 0 | 1 | 1 | 1 | 1 | 1 | 1 | 1 | 1 | 1 | 1 | 0 | 1 | 1 |
| 8 | 1 | 0 | 0 | 0 | 1 | 1 | 1 | 1 | 1 | 1 | 1 | 1 | 0 | 1 |
| 9 | 1 | 0 | 0 | 1 | 1 | 1 | 1 | 1 | 1 | 1 | 1 | 1 | 1 | 0 |
| INVALID | 1 | 0 | 1 | 0 | 1 | 1 | 1 | 1 | 1 | 1 | 1 | 1 | 1 | 1 |
| | 1 | 0 | 1 | 1 | 1 | 1 | 1 | 1 | 1 | 1 | 1 | 1 | 1 | 1 |
| | 1 | 1 | 0 | 0 | 1 | 1 | 1 | 1 | 1 | 1 | 1 | 1 | 1 | 1 |
| | 1 | 1 | 0 | 1 | 1 | 1 | 1 | 1 | 1 | 1 | 1 | 1 | 1 | 1 |
| | 1 | 1 | 1 | 0 | 1 | 1 | 1 | 1 | 1 | 1 | 1 | 1 | 1 | 1 |
| | 1 | 1 | 1 | 1 | 1 | 1 | 1 | 1 | 1 | 1 | 1 | 1 | 1 | 1 |

P.5.12474xx45 (BCD-to-Decimal Dec)

This BCD-to-decimal decoder consists of eight inverters and ten four-input NAND gates.

BCD-to-decimal truth table:

| No. | INPUTS | | | | OUTPUTS | | | | | | | | | |
|---------|--------|---|---|---|---------|---|---|---|---|---|---|---|---|---|
| | D | C | B | A | 0 | 1 | 2 | 3 | 4 | 5 | 6 | 7 | 8 | 9 |
| 0 | 0 | 0 | 0 | 0 | 0 | 1 | 1 | 1 | 1 | 1 | 1 | 1 | 1 | 1 |
| 1 | 0 | 0 | 0 | 1 | 1 | 0 | 1 | 1 | 1 | 1 | 1 | 1 | 1 | 1 |
| 2 | 0 | 0 | 1 | 0 | 1 | 1 | 0 | 1 | 1 | 1 | 1 | 1 | 1 | 1 |
| 3 | 0 | 0 | 1 | 1 | 1 | 1 | 1 | 0 | 1 | 1 | 1 | 1 | 1 | 1 |
| 4 | 0 | 1 | 0 | 0 | 1 | 1 | 1 | 1 | 0 | 1 | 1 | 1 | 1 | 1 |
| 5 | 0 | 1 | 0 | 1 | 1 | 1 | 1 | 1 | 1 | 0 | 1 | 1 | 1 | 1 |
| 6 | 0 | 1 | 1 | 0 | 1 | 1 | 1 | 1 | 1 | 1 | 0 | 1 | 1 | 1 |
| 7 | 0 | 1 | 1 | 1 | 1 | 1 | 1 | 1 | 1 | 1 | 1 | 0 | 1 | 1 |
| 8 | 1 | 0 | 0 | 0 | 1 | 1 | 1 | 1 | 1 | 1 | 1 | 1 | 0 | 1 |
| 9 | 1 | 0 | 0 | 1 | 1 | 1 | 1 | 1 | 1 | 1 | 1 | 1 | 1 | 0 |
| INVALID | 1 | 0 | 1 | 0 | 1 | 1 | 1 | 1 | 1 | 1 | 1 | 1 | 1 | 1 |
| | 1 | 0 | 1 | 1 | 1 | 1 | 1 | 1 | 1 | 1 | 1 | 1 | 1 | 1 |
| | 1 | 1 | 0 | 0 | 1 | 1 | 1 | 1 | 1 | 1 | 1 | 1 | 1 | 1 |
| | 1 | 1 | 0 | 1 | 1 | 1 | 1 | 1 | 1 | 1 | 1 | 1 | 1 | 1 |
| | 1 | 1 | 1 | 0 | 1 | 1 | 1 | 1 | 1 | 1 | 1 | 1 | 1 | 1 |
| | 1 | 1 | 1 | 1 | 0 | 1 | 1 | 1 | 1 | 1 | 1 | 1 | 1 | 1 |
| | 1 | 1 | 1 | 1 | 1 | 1 | 1 | 1 | 1 | 1 | 1 | 1 | 1 | 1 |

P.5.12574xx46 (BCD-to-seven segment dec)

The 7446 BCD (Binary-Coded Decimal)-to-seven-segment decoder translates a 4-bit BCD input into hexadecimal, and outputs high on the output pins corresponding to the hexadecimal representation of the BCD input. There are provisions for lamp testing and for blanking the outputs.

BCD-to-seven-segment decoder:

| No. | INPUTS | | | | | | OUTPUTS | | | | | | | | |
|-----|------------------------|-------------------------|---|---|---|---|----------------------------------------------|---|---|---|---|---|---|---|---|
| | $\overline{\text{LT}}$ | $\overline{\text{RBI}}$ | D | C | B | A | $\overline{\text{BI}}/\overline{\text{RBO}}$ | a | b | c | d | e | f | | g |
| 0 | 1 | 1 | 0 | 0 | 0 | 0 | 1 | 1 | 1 | 1 | 1 | 1 | 1 | 0 | |
| 1 | 1 | X | 0 | 0 | 0 | 1 | 1 | 0 | 1 | 1 | 0 | 0 | 0 | 0 | |
| 2 | 1 | X | 0 | 0 | 1 | 0 | 1 | 1 | 1 | 0 | 1 | 1 | 0 | 1 | |
| 3 | 1 | X | 0 | 0 | 1 | 1 | 1 | 1 | 1 | 1 | 1 | 0 | 0 | 1 | |
| 4 | 1 | X | 0 | 1 | 0 | 0 | 1 | 0 | 1 | 1 | 0 | 0 | 1 | 1 | |
| 5 | 1 | X | 0 | 1 | 0 | 1 | 1 | 1 | 0 | 1 | 1 | 0 | 1 | 1 | |
| 6 | 1 | X | 0 | 1 | 1 | 0 | 1 | 0 | 0 | 1 | 1 | 1 | 1 | 0 | |
| 7 | 1 | X | 0 | 1 | 1 | 1 | 1 | 1 | 1 | 1 | 0 | 0 | 0 | 0 | |
| 8 | 1 | X | 1 | 0 | 0 | 0 | 1 | 1 | 1 | 1 | 1 | 1 | 1 | 1 | |
| 9 | 1 | X | 1 | 0 | 0 | 1 | 1 | 1 | 1 | 1 | 0 | 0 | 1 | 1 | |
| 10 | 1 | X | 1 | 0 | 1 | 0 | 1 | 0 | 0 | 0 | 1 | 1 | 0 | 1 | |
| 11 | 1 | X | 1 | 0 | 1 | 1 | 1 | 0 | 0 | 1 | 1 | 0 | 0 | 1 | < |
| 12 | 1 | X | 1 | 1 | 0 | 0 | 1 | 0 | 1 | 0 | 0 | 0 | 1 | 1 | |
| 13 | 1 | X | 1 | 1 | 0 | 1 | 1 | 1 | 0 | 0 | 1 | 0 | 1 | 1 | < |
| 14 | 1 | X | 1 | 1 | 1 | 0 | 1 | 0 | 0 | 0 | 1 | 1 | 1 | 1 | |
| 15 | 1 | X | 1 | 1 | 1 | 1 | 1 | 0 | 0 | 0 | 0 | 0 | 0 | 0 | |
| BI | X | X | X | X | X | X | 0 | 0 | 0 | 0 | 0 | 0 | 0 | 0 | |
| RBI | 1 | 0 | 0 | 0 | 0 | 0 | 0 | 0 | 0 | 0 | 0 | 0 | 0 | 0 | |
| LT | 0 | X | X | X | X | X | 1 | 1 | 1 | 1 | 1 | 1 | 1 | 1 | |

INVALID

P.5.12674xx465 (Octal BUFFER w/3-state Out)

This device has a two-input active-low AND enable gate controlling all eight data buffers.

Octal buffers truth table:

| $\overline{\text{G1}}$ | $\overline{\text{G2}}$ | A | Y |
|------------------------|------------------------|---|---|
| 0 | 0 | 0 | 0 |
| 0 | 0 | 1 | 1 |
| 1 | 0 | X | Z |
| 0 | 1 | X | Z |
| 1 | 1 | X | Z |

Z = High impedance (off)

P.5.12774xx466 (Octal BUFFER w/3-state Out)

This device has a two-input active-low AND enable gate controlling all eight data buffers.

Octal buffers truth table:

| $\bar{G}1$ | $\bar{G}2$ | A | Y |
|------------|------------|---|---|
| 0 | 0 | 0 | 1 |
| 0 | 0 | 1 | 0 |
| 1 | 0 | X | Z |
| 0 | 1 | X | Z |
| 1 | 1 | X | Z |

Z = High impedance (off)

P.5.12874xx47 (BCD-to-seven segment dec)

The 7447 BCD (Binary-Coded Decimal)-to-seven-segment decoder translates a 4-bit BCD input into hexadecimal, and outputs high on the output pins corresponding to the hexadecimal representation of the BCD input. There are provisions for lamp testing and for blanking the outputs.

BCD-to-seven-segment decoder truth table:

| No. | INPUTS | | | | | | OUTPUTS | | | | | | | |
|-----|------------------------|-------------------------|---|---|---|---|----------------------------------------------|---|---|---|---|---|---|---|
| | $\overline{\text{LT}}$ | $\overline{\text{RBI}}$ | D | C | B | A | $\overline{\text{BI}}/\overline{\text{RBO}}$ | a | b | c | d | e | f | g |
| 0 | 1 | 1 | 0 | 0 | 0 | 0 | 1 | 1 | 1 | 1 | 1 | 1 | 1 | 0 |
| 1 | 1 | X | 0 | 0 | 0 | 1 | 1 | 0 | 1 | 1 | 0 | 0 | 0 | 0 |
| 2 | 1 | X | 0 | 0 | 1 | 0 | 1 | 1 | 1 | 0 | 1 | 1 | 0 | 1 |
| 3 | 1 | X | 0 | 0 | 1 | 1 | 1 | 1 | 1 | 1 | 1 | 0 | 0 | 1 |
| 4 | 1 | X | 0 | 1 | 0 | 0 | 1 | 0 | 1 | 1 | 0 | 0 | 1 | 1 |
| 5 | 1 | X | 0 | 1 | 0 | 1 | 1 | 1 | 0 | 1 | 1 | 0 | 1 | 1 |
| 6 | 1 | X | 0 | 1 | 1 | 0 | 1 | 0 | 0 | 1 | 1 | 1 | 1 | 0 |
| 7 | 1 | X | 0 | 1 | 1 | 1 | 1 | 1 | 1 | 1 | 0 | 0 | 0 | 0 |
| 8 | 1 | X | 1 | 0 | 0 | 0 | 1 | 1 | 1 | 1 | 1 | 1 | 1 | 1 |
| 9 | 1 | X | 1 | 0 | 0 | 1 | 1 | 1 | 1 | 1 | 0 | 0 | 1 | 1 |
| 10 | 1 | X | 1 | 0 | 1 | 0 | 1 | 0 | 0 | 0 | 1 | 1 | 0 | 1 |
| 11 | 1 | X | 1 | 0 | 1 | 1 | 1 | 0 | 0 | 1 | 1 | 0 | 0 | 1 |
| 12 | 1 | X | 1 | 1 | 0 | 0 | 1 | 0 | 1 | 0 | 0 | 0 | 1 | 1 |
| 13 | 1 | X | 1 | 1 | 0 | 1 | 1 | 1 | 0 | 0 | 1 | 0 | 1 | 1 |
| 14 | 1 | X | 1 | 1 | 1 | 0 | 1 | 0 | 0 | 0 | 1 | 1 | 1 | 1 |
| 15 | 1 | X | 1 | 1 | 1 | 1 | 1 | 0 | 0 | 0 | 0 | 0 | 0 | 0 |
| BI | X | X | X | X | X | X | 0 | 0 | 0 | 0 | 0 | 0 | 0 | 0 |
| RBI | 1 | 0 | 0 | 0 | 0 | 0 | 0 | 0 | 0 | 0 | 0 | 0 | 0 | 0 |
| LT | 0 | X | X | X | X | X | 1 | 1 | 1 | 1 | 1 | 1 | 1 | 1 |

I
N
V
A
L
I
D

$\overline{\text{BI}}$ = active-low blanking input

$\overline{\text{RBI}}$ = active-low ripple-blanking input

$\overline{\text{LT}}$ = active-low lamp-test input

Notes:

1. The blanking input ($\overline{\text{BI}}$) must be open or held at a high logic level when output functions 0 through 15 are desired. The ripple-blanking input ($\overline{\text{RBI}}$) must be open or high if blanking of a decimal zero is not desired.
2. When a low logic level is applied to the blanking input ($\overline{\text{BI}}$), all segment outputs are low regardless of any other input level.
3. To place the device in lamp-test mode, $\overline{\text{RBO}}$ must be high when $\overline{\text{LT}}$ is low. This forces all lamps on.

P.5.12974xx48 (BCD-to-seven segment dec)

This device features active-high outputs for driving lamp buffers or common-cathode VLEDs. It also has full ripple-blanking input/output controls and a lamp test input.

BCD-to-seven-segment decoder:

| No. | INPUTS | | | | | | | OUTPUTS | | | | | | |
|-----|------------------------|-------------------------|---|---|---|---|----------------------------------------------|---------|---|---|---|---|---|---|
| | $\overline{\text{LT}}$ | $\overline{\text{RBI}}$ | D | C | B | A | $\overline{\text{BI}}/\overline{\text{RBO}}$ | a | b | c | d | e | f | g |
| 0 | 1 | 1 | 0 | 0 | 0 | 0 | 1 | 1 | 1 | 1 | 1 | 1 | 1 | 0 |
| 1 | 1 | X | 0 | 0 | 0 | 1 | 1 | 0 | 1 | 1 | 0 | 0 | 0 | 0 |
| 2 | 1 | X | 0 | 0 | 1 | 0 | 1 | 1 | 1 | 0 | 1 | 1 | 0 | 1 |
| 3 | 1 | X | 0 | 0 | 1 | 1 | 1 | 1 | 1 | 1 | 1 | 0 | 0 | 1 |
| 4 | 1 | X | 0 | 1 | 0 | 0 | 1 | 0 | 1 | 1 | 0 | 0 | 1 | 1 |
| 5 | 1 | X | 0 | 1 | 0 | 1 | 1 | 1 | 0 | 1 | 1 | 0 | 1 | 1 |
| 6 | 1 | X | 0 | 1 | 1 | 0 | 1 | 0 | 0 | 1 | 1 | 1 | 1 | 0 |
| 7 | 1 | X | 0 | 1 | 1 | 1 | 1 | 1 | 1 | 1 | 1 | 0 | 0 | 0 |
| 8 | 1 | X | 1 | 0 | 0 | 0 | 1 | 1 | 1 | 1 | 1 | 1 | 1 | 1 |
| 9 | 1 | X | 1 | 0 | 0 | 1 | 1 | 1 | 1 | 1 | 0 | 0 | 1 | 1 |
| 10 | 1 | X | 1 | 0 | 1 | 0 | 1 | 0 | 0 | 0 | 1 | 1 | 0 | 1 |
| 11 | 1 | X | 1 | 0 | 1 | 1 | 1 | 1 | 0 | 0 | 1 | 1 | 0 | 1 |
| 12 | 1 | X | 1 | 1 | 0 | 0 | 1 | 0 | 1 | 0 | 0 | 0 | 1 | 1 |
| 13 | 1 | X | 1 | 1 | 0 | 1 | 1 | 1 | 0 | 0 | 1 | 0 | 1 | 1 |
| 14 | 1 | X | 1 | 1 | 1 | 0 | 1 | 0 | 0 | 0 | 1 | 1 | 1 | 1 |
| 15 | 1 | X | 1 | 1 | 1 | 1 | 1 | 1 | 0 | 0 | 0 | 0 | 0 | 0 |
| BI | X | X | X | X | X | X | 0 | 0 | 0 | 0 | 0 | 0 | 0 | 0 |
| RBI | 1 | 0 | 0 | 0 | 0 | 0 | 0 | 0 | 0 | 0 | 0 | 0 | 0 | 0 |
| LT | 0 | X | X | X | X | X | 1 | 1 | 1 | 1 | 1 | 1 | 1 | 1 |

INV
ALI
D

$\overline{\text{BI}}$ = active-low blanking input

$\overline{\text{RBI}}$ = active-low ripple-blanking input

$\overline{\text{LT}}$ = active-low lamp-test input

Notes:

1. The blanking input ($\overline{\text{BI}}$) must be open or held at a high logic level when output functions 0 through 15 are desired. The ripple-blanking input ($\overline{\text{RBI}}$) must be open or high if blanking of a decimal zero is not desired.
2. When a low logic level is applied to the blanking input ($\overline{\text{BI}}$), all segment outputs are low regardless of any other input level.
3. To place the device in lamp-test mode, $\overline{\text{RBO}}$ must be high when $\overline{\text{LT}}$ is low. This forces all lamps on.

P.5.13074xx51 (AND-OR-INVERTER)

AND-OR INVERTER gate truth table:

| A | B | C | D | Y |
|---|---|---|---|---|
| 0 | X | X | 0 | 1 |
| X | 0 | 0 | X | 1 |
| 0 | X | 0 | X | 1 |
| X | 0 | X | 0 | 1 |
| 1 | 1 | X | X | 0 |
| X | X | 1 | 1 | 0 |

P.5.13174xx54 (4-wide AND-OR-INVERTER)

4-wide AND-OR-INVERTER truth table:

| INPUTS | | | | | | | | OUTPUT |
|--------|---|---|---|---|---|---|---|--------|
| A | B | C | D | E | F | G | H | Y |
| 1 | 1 | X | X | X | X | X | X | 0 |
| X | X | 1 | 1 | X | X | X | X | 0 |
| X | X | X | X | 1 | 1 | X | X | 0 |
| X | X | X | X | X | X | 1 | 1 | 0 |
| X | X | X | X | X | X | X | X | 1 |

P.5.13274xx55 (2-wide 4-In AND-OR-INVERTER)

AND-OR-INVERTER truth table:

| INPUTS | | | | | | | | OUTPUT |
|--------|---|---|---|---|---|---|---|--------|
| A | B | C | D | E | F | G | H | Y |
| 1 | 1 | 1 | 1 | 1 | 1 | 1 | 1 | 0 |
| 1 | 1 | 1 | 1 | X | X | X | X | 0 |
| X | X | X | X | 1 | 1 | 1 | 1 | 0 |
| X | X | X | X | X | X | X | X | 1 |

P.5.13374xx69 (Dual 4-bit Binary Counter)

Counter number one has two sections - counter A (divide-by-2 section) and counter B, C, D (divide-by-8 section). Counter number two has only divide-by-sixteen section.

4-Bit counter truth table:

| $\overline{1CLR}$ | $\overline{2CLR}$ | 1QA | 1QB | 1QC | 1QD | 2QA | 2QB | 2QC | 2QD |
|-------------------|-------------------|-------|-----|-----|-----|-------|-----|-----|-----|
| 1 | 1 | COUNT | | | | COUNT | | | |
| 1 | 0 | COUNT | | | | 0 | 0 | 0 | 0 |
| 0 | 1 | 0 | 0 | 0 | 0 | COUNT | | | |
| 0 | 0 | 0 | 0 | 0 | 0 | 0 | 0 | 0 | 0 |

P.5.13474xx72 (AND-gated JK MS-SLV FF (pre, clr))

This device is equipped with an active-low pre and active-low clr. Therefore, the flip-flop begins accepting input from the JK input when the preset and clear are both high (hence AND-gated).

AND-gated JK flip-flop truth table:

| \overline{PRE} | \overline{CLR} | CLK | J | K | Q | \overline{Q} |
|------------------|------------------|-----|---|---|----------|-----------------|
| 0 | 1 | X | X | X | 1 | 0 |
| 1 | 0 | X | X | X | 0 | 1 |
| 0 | 0 | X | X | X | UNSTABLE | |
| 1 | 1 | · | 0 | 0 | Q0 | $\overline{Q0}$ |
| 1 | 1 | · | 1 | 0 | 1 | 0 |
| 1 | 1 | · | 0 | 1 | 0 | 1 |
| 1 | 1 | · | 1 | 1 | Toggle | |

· = triggers on pulse (level sensitive)

P.5.13574xx73 (Dual JK FF (clr))

This device contains 2-independent JK flip-flops.

JK flip-flop truth table:

| $\overline{\text{CLR}}$ | CLK | J | K | Q | $\overline{\text{Q}}$ |
|-------------------------|-----|---|---|--------|-----------------------|
| 0 | X | X | X | 0 | 1 |
| 1 | . | 0 | 0 | Hold | |
| 1 | . | 1 | 0 | 1 | 0 |
| 1 | . | 0 | 1 | 0 | 1 |
| 1 | . | 1 | 1 | Toggle | |

. = triggers on pulse (level sensitive)

P.5.13674xx74 (Dual D-type FF (pre, clr))

This device is equipped with active-low preset and active-low clear inputs.

D-type positive-edge-triggered flip-flop truth table:

| $\overline{\text{PRE}}$ | $\overline{\text{CLR}}$ | CLK | D | Q | $\overline{\text{Q}}$ |
|-------------------------|-------------------------|-----|---|------|-----------------------|
| 0 | 1 | X | X | 1 | 0 |
| 1 | 0 | X | X | 0 | 1 |
| 0 | 0 | X | X | 1 | 1 |
| 1 | 1 | . | 1 | 1 | 0 |
| 1 | 1 | . | 0 | 0 | 1 |
| 1 | 1 | 0 | X | Hold | |

. = positive edge-triggered

P.5.13774xx75 (4-bit Bistable Latches)

This device features complementary Q and $\overline{\text{Q}}$ outputs from a 4-bit latch.

Bistable latch truth table:

| INPUTS | | OUTPUTS | |
|--------|---|---------|------------------------|
| D | C | Q | $\overline{\text{Q}}$ |
| 0 | 1 | 0 | 1 |
| 1 | 1 | 1 | 0 |
| X | 0 | Q0 | $\overline{\text{Q0}}$ |

P.5.13874xx76 (Dual JK FF (pre, clr))

This device contains two independent J-K flip-flops with individual J-K, clock, preset, and clear inputs.

JK flip-flop truth table:

| $\overline{\text{PRE}}$ | $\overline{\text{CLR}}$ | CLK | $\overline{\text{J}}$ | K | Q | $\overline{\text{Q}}$ |
|-------------------------|-------------------------|-----|-----------------------|---|--------|-----------------------|
| 0 | 1 | X | X | X | 1 | 0 |
| 1 | 0 | X | X | X | 0 | 1 |
| 0 | 0 | X | X | X | 1 | 1 |
| 1 | 1 | · | 0 | 0 | Hold | |
| 1 | 1 | · | 1 | 0 | 1 | 0 |
| 1 | 1 | · | 0 | 1 | 0 | 1 |
| 1 | 1 | · | 1 | 1 | Toggle | |

· = pulse triggered (level sensitive)

P.5.13974xx77 (4-bit Bistable Latches)

This 4-bit latch is available in a 14-pin flat package.

Bistable latch truth table:

| D | C | L | H |
|---|---|------|---|
| 0 | 1 | 1 | 0 |
| 1 | 1 | 1 | 0 |
| X | 0 | Hold | |

P.5.14074xx78 (Dual JK FF (pre, com clk & clr))

The 7478 contains two negative-edge triggered flip-flops with individual JK, individual preset, common clock and common clear inputs.

JK flip-flop truth table:

| PRESET | CLEAR | J | K | CLOCK | Q | \bar{Q} |
|--------|-------|---|---|-------|----|---------------|
| 0 | 1 | X | X | X | 1 | 0 |
| 1 | 0 | X | X | X | 0 | 1 |
| 0 | 0 | X | X | X | 1* | 1* (unstable) |
| 1 | 1 | 0 | 0 | , | | (no change) |
| 1 | 1 | 0 | 1 | , | 0 | 1 |
| 1 | 1 | 1 | 0 | , | 1 | 0 |
| 1 | 1 | 1 | 1 | , | | (toggle) |
| 1 | 1 | X | X | 1 | | (no change) |

* = This configuration will not persist when preset and clear are inactive.

,

P.5.14174xx82 (2-bit Bin Full Adder)

This device performs the addition of two 2-bit binary numbers.

2-bit binary full adder truth table:

| INPUTS | | | | OUTPUTS | | | | | |
|--------|----|----|----|-------------|----|----|-------------|----|----|
| A1 | B1 | A2 | B2 | WHEN CO = L | | | WHEN CO = H | | |
| | | | | S1 | S2 | C2 | S1 | S2 | C2 |
| 0 | 0 | 0 | 0 | 0 | 0 | 0 | 1 | 0 | 0 |
| 1 | 0 | 0 | 0 | 1 | 0 | 0 | 0 | 1 | 0 |
| 0 | 1 | 0 | 0 | 1 | 0 | 0 | 0 | 1 | 0 |
| 1 | 1 | 0 | 0 | 0 | 1 | 0 | 1 | 1 | 0 |
| 0 | 0 | 1 | 0 | 0 | 1 | 0 | 1 | 1 | 0 |
| 1 | 0 | 1 | 0 | 1 | 1 | 0 | 0 | 0 | 1 |
| 0 | 1 | 1 | 0 | 1 | 1 | 0 | 0 | 0 | 1 |
| 1 | 1 | 1 | 0 | 0 | 0 | 1 | 1 | 0 | 1 |
| 0 | 0 | 0 | 1 | 0 | 1 | 0 | 1 | 1 | 0 |
| 1 | 0 | 0 | 1 | 1 | 1 | 0 | 0 | 0 | 1 |
| 0 | 1 | 0 | 1 | 1 | 1 | 0 | 0 | 0 | 1 |
| 1 | 1 | 0 | 1 | 0 | 0 | 1 | 1 | 0 | 1 |
| 0 | 0 | 1 | 1 | 0 | 0 | 1 | 1 | 0 | 1 |
| 1 | 0 | 1 | 1 | 1 | 0 | 1 | 0 | 1 | 1 |
| 0 | 1 | 1 | 1 | 1 | 0 | 1 | 0 | 1 | 1 |
| 1 | 1 | 1 | 1 | 0 | 1 | 1 | 1 | 1 | 1 |

P.5.14274xx83 (4-bit Bin Full Adder)

This device performs the addition of two 4-bit binary numbers. It features full internal look-ahead across all four bits generating the carry term in ten nanoseconds typically.

P.5.14374xx85 (4-bit Mag COMP)

This 4-bit magnitude comparator performs comparison of straight binary and straight BCD (8-4-2-1) codes.

4-bit magnitude comparator truth table:

| A3, B3 | COMPARING INPUTS | | | CASCADING INPUTS | | | OUTPUTS | | |
|--------|---------------------|--------|--------|---------------------|-----|-----|---------|-----|-----|
| | A2, B2 | A1, B1 | A0, B0 | A>B | A<B | A=B | A>B | A<B | A=B |
| A3>B3 | X | X | X | X | X | X | 1 | 0 | 0 |
| A3<B3 | X | X | X | X | X | X | 0 | 1 | 0 |
| A3=B3 | A2>B2 | X | X | X | X | X | 1 | 0 | 0 |
| A3=B3 | A2<B2 | X | X | X | X | X | 0 | 1 | 0 |
| A3=B3 | A2=B2 | A1>B1 | X | X | X | X | 1 | 0 | 0 |
| A3=B3 | A2=B2 | A1<B1 | X | X | X | X | 0 | 1 | 0 |
| A3=B3 | A2=B2 | A1=B1 | A0>B0 | X | X | X | 1 | 0 | 0 |
| A3=B3 | A2=B2 | A1=B1 | A0<B0 | X | X | X | 0 | 1 | 0 |
| A3=B3 | A2=B2 | A1=B1 | A0=B0 | 1 | 0 | 0 | 1 | 0 | 0 |
| A3=B3 | A2=B2 | A1=B1 | A0=B0 | 0 | 1 | 0 | 0 | 1 | 0 |
| A3=B3 | A2=B2 | A1=B1 | A0=B0 | 0 | 0 | 1 | 0 | 0 | 1 |
| A3=B3 | A2=B2 | A1=B1 | A0=B0 | X | X | 1 | 0 | 0 | 1 |
| A3=B3 | A2=B2 | A1=B1 | A0=B0 | 1 | 1 | 0 | 0 | 0 | 0 |
| A3=B3 | A2=B2 | A1=B1 | A0=B0 | 0 | 0 | 0 | 1 | 1 | 0 |
| A3=B3 | A2=B2 | A1=B1 | A0=B0 | 0 | 1 | 1 | 0 | 1 | 1 |
| A3=B3 | A2=B2 | A1=B1 | A0=B0 | 1 | 0 | 1 | 1 | 0 | 1 |
| A3=B3 | A2=B2 | A1=B1 | A0=B0 | 1 | 1 | 1 | 1 | 1 | 1 |
| A3=B3 | A2=B2 | A1=B1 | A0=B0 | 1 | 1 | 0 | 1 | 1 | 0 |
| A3=B3 | A2=B2 | A1=B1 | A0=B0 | 0 | 0 | 0 | 0 | 0 | 0 |

P.5.14474xx86 (Quad 2-In XOR)

Logic function:

$$Y = \bar{A} \oplus \bar{B}$$

EXCLUSIVE-OR gate truth table:

| A | B | Y |
|---|---|---|
| 0 | 0 | 0 |
| 0 | 1 | 1 |
| 1 | 0 | 1 |
| 1 | 1 | 0 |

P.5.14574xx90 (Decade Counter)

The 7490 counts from 0 to 9 in binary. It contains four master-slave flip-flops and additional gating to provide a divide-by-two counter and a three-stage binary counter for which the count cycle length is divide-by-five.

Decade counter truth table:

| RESET INPUTS | | | | OUTPUT | | | |
|--------------|--------|--------|--------|--------|----|----|----|
| R0 (1) | R0 (2) | R9 (1) | R9 (2) | Qd | Qc | Qb | Qa |
| 1 | 1 | 0 | X | 0 | 0 | 0 | 0 |
| 1 | 1 | X | 0 | 0 | 0 | 0 | 0 |
| X | X | 1 | 1 | 1 | 0 | 0 | 1 |
| X | 0 | X | 0 | COUNT | | | |
| 0 | X | 0 | X | COUNT | | | |
| 0 | X | X | 0 | COUNT | | | |
| X | 0 | 0 | X | COUNT | | | |

P.5.14674xx91 (8-bit Shift Reg)

This 8-bit shift register contains eight R-S master-slave flip-flops, input gating, and a clock driver.

Shift register truth table:

| A | B | Qh | Qh |
|---|---|----|----|
| 1 | 1 | 1 | 0 |
| 0 | X | 0 | 1 |
| X | 0 | 0 | 1 |

| $\overline{\text{CLR}}$ | PRESET | | PRESET | | | | CLK | SERIAL | OUTPUTS | | | | |
|-------------------------|--------|--|--------|---|---|---|-----|--------|---------|-----|-----|-----|-----|
| | ENABLE | | A | B | C | D | | | QA | QB | QC | QD | QE |
| 0 | 0 | | X | X | X | X | X | X | 0 | 0 | 0 | 0 | 0 |
| 0 | X | | 0 | 0 | 0 | 0 | X | X | 0 | 0 | 0 | 0 | 0 |
| 1 | 1 | | 1 | 1 | 1 | 1 | X | X | 1 | 1 | 1 | 1 | 1 |
| 1 | 1 | | 0 | 0 | 0 | 0 | 0 | X | QA0 | QB0 | QC0 | QD0 | QE0 |
| 1 | 1 | | 1 | 0 | 1 | 0 | 0 | X | 1 | QB0 | 1 | QD0 | 1 |
| 1 | 0 | | X | X | X | X | 0 | X | QA0 | QB0 | QC0 | QD0 | QE0 |
| 1 | 0 | | X | X | X | X | . | 1 | 1 | QAn | QBn | QCn | QDn |
| 1 | 0 | | X | X | X | X | . | 0 | 0 | QAn | QBn | QCn | QDn |

- .
- . = transition from low to high level
- QA0, QB0, etc. = the level of QA, QB, etc. respectively before the indicated steady state input conditions were established
- QAn, QBn, etc. = the level of QA, QB, etc. respectively before the most recent negative transition of the clock

P.5.14774xx92 (Divide-by-twelve Counter)

The 7492 counts from 0 to 11 in binary. It contains four master-slave flip-flops and additional gating to provide a divide-by-two counter and a three-stage binary counter for which the count cycle length is divide-by-six.

Counter truth table:

| RESET INPUTS | | OUTPUT | | | |
|--------------|-----|--------|----|----|----|
| RO1 | RO2 | Qd | Qc | Qb | Qa |
| 1 | 1 | 0 | 0 | 0 | 0 |
| 0 | X | Count | | | |
| X | 0 | Count | | | |

P.5.14874xx93 (4-bit Binary Counter)

The 7493 counts from 0 to 15 in binary. It contains four master-slave flip-flops and additional gating to provide a divide-by-two counter and a three-stage binary counter for which the count cycle length is divide-by-eight.

Binary counter truth table:

| RESET INPUTS | | OUTPUT | | | |
|--------------|-----|--------|----|----|----|
| RO1 | RO2 | Qd | Qc | Qb | Qa |
| 1 | 1 | 0 | 0 | 0 | 0 |
| 0 | X | Count | | | |
| X | 0 | Count | | | |

Index

Numerics

- 10-to-4 Priority Enc P-16
- 12-In NAND w/3-state Out P-12
- 12-stage Binary Counter O-24
- 13-In NAND P-12
- 13-input Checker/Generator O-48
- 14-stage Bin Counter O-16
- 1-of-10 Dec O-20
- 1-of-16 Data Sel/MUX P-17
- 1-of-16 Dec/DEMUX w/Input latches
 - 4514 O-43
 - 4515 O-44
- 1-of-8 Data Sel/MUX P-18
- 2-bit Bin Full Adder P-78
- 2-wide 4-In AND-OR-INVERTER P-74
- 3 3-Input AND P-17
- 3-to-8 Dec P-13
- 3-to-8 line Dec/DEMUX P-39
- 4000 series functions *See functions*
- 4000 series ICs O-2
- 4-BCD to 10-Decimal Dec P-64
- 4-bit BCD Down Counter O-48
- 4-bit Bidirect Univ. Shift Reg P-35
- 4-bit Bin Counter O-10
 - 40161 O-10
 - 40193 O-15
- 4-bit Bin Down Counter O-48
- 4-bit Bin Full Add P-50
- 4-bit Bin Full Adder P-79
- 4-bit Bin/BCD Dec Counter O-21
- 4-bit Binary Counter
 - 74xx293 P-51
 - 74xx93 P-82
- 4-bit Binary Full Adder O-4
- 4-bit Bistable Latches
 - 74xx375 P-59
 - 74xx75 P-76
 - 74xx77 P-77
- 4-bit Cascadable Shift Reg w/3-state Out P-63
- 4-bit Comparator O-54
- 4-bit Dec Counter
 - 40160 O-9
 - 40162 O-10
 - 40192 O-14
- 4-bit D-type Reg w/3-state Out P-29
- 4-bit Mag COMP P-79
- 4-bit Parallel-Access Shift Reg P-35
- 4-bit Shift Register
 - 40194 O-15
 - 40195 O-15
 - 4035 O-22
- 4-bit Shifter w/3-state Out P-53
- 4-to-16 Dec/DEMUX P-19
- 4-to-16 Dec/DEMUX (OC) P-22
- 4-Wide 2-In AND-OR-INVERTER O-36
- 4-wide AND-OR-INVERTER P-74
- 5-stage Johnson Counter
 - 4017 O-11
 - 4018 O-13
- 74xx series functions *See functions*
- 7-stage Binary Counter O-17
- 8-Bit Bist Latch P-6
- 8-bit Latch
 - 4099 O-38
 - 74xx259 P-47
- 8-bit Parallel-Out Serial Shift Reg P-26
- 8-bit Priority Enc O-49
- 8-bit Shift Reg P-80
- 8-bit Shift Reg (sh/ld ctrl) P-37

- 8-bit Shift Reg (shl/shr ctrl) P-36
- 8-bit Static Shift Reg O-7
- 8-bit Static Shift Register O-16
- 8-In MUX w/3-state Out O-42
- 8-In NAND
 - 4068 O-28
 - 74xx30 P-52
- 8-In NOR O-32
- 8-stage Serial Shift Register O-37
- 8-to-3 Priority Enc P-16
- 9-bit Odd/even Par GEN P-30
- 9-bit odd/even parity generator/checker P-50

A

- AC current source C-4
- AC frequency model
 - capacitors D-7
 - inductors D-10
- AC model F-9
- AC small-signal model
 - bipolar junction transistors F-5
 - diac E-15
 - diodes E-4
 - MOSFET F-13
 - SCR E-14
- AC voltage source C-3
- ADC DAC I-1
- Alu/Function Generator P-31
- AM source. *See* amplitude modulation source
- ammeter
 - about J-2
 - connecting J-2
 - mode J-2
 - resistance J-2
- amplifiers, wide bandwidth G-11
- amplitude modulation source C-4
- analog components
 - bipolar junction transistors (*see also* bipolar

- junction transistors) F-1
- BJT arrays (*see also* BJT arrays) F-9
- comparator G-9
- Darlington connection (*see also* Darlington connection) F-8
- diac (*see also* diac) E-14
- diodes (*see also* diodes) E-1
- DMOS transistor F-19
- full-wave bridge rectifier (*see also* full-wave bridge rectifier) E-10
- GaAsFET (*see also* GaAsFET) F-19
- IGBT-IGBT F-21
- LED (Light-Emitting Diode) (*see also* LED) E-8
- MOSFET (*see also* MOSFET) F-10
- Norton opamps G-8
- opamps (*see also* opamps) G-1
- optocoupler K-4
- PIN diode E-6
- Schottky diode E-12
- SCR (Silicon-Controlled Rectifier) (*see also* SCR) E-12
- triac E-16
- triode vacuum tube (*see also* triode vacuum tube) K-4
- varactor diode E-18
- voltage reference K-6
- voltage regulator K-7
- voltage suppressor K-8
- voltage-controlled analog I-2
- wide bandwidth amplifiers G-11
- zener diode (*see also* zener diode) E-6

analog switch I-2

AND-gated JK MS-SLV FF (pre, clr) P-75

AND-OR-INVERTER P-74

arrays, BJT F-9

B

bargraph, about J-6

battery C-2

BCD up/down Counter O-40
 BCD-to-Decimal Dec
 74xx145 P-15
 74xx445 P-67
 74xx45 P-68
 BCD-to-seven segment dec
 74xx246 P-41
 74xx247 P-42
 74xx248 P-43
 74xx249 P-44
 74xx46 P-69
 74xx47 P-71
 74xx48 P-73
 BCD-to-seven segment latch/dec
 4511 O-41
 4544 O-52
 BCD-to-seven segment latch/dec/driver O-50
 Binary up/down Counter O-45
 bipolar junction transistors
 about F-1
 AC small-signal model F-5
 characteristic equations F-2
 parameters and defaults F-6
 time-domain model F-4
 BJT arrays
 about F-9
 general-purpose high-current N-P-N
 transistor array F-10
 general-purpose P-N-P transistor array F-
 10
 N-P-N/P-N-P transistor array F-10
 BJT. *See* bipolar junction transistors
 BJT_NRES F-8
 boost converter K-8
 buck boost converter K-12
 buck converter K-10
 buzzer, about J-7

C

capacitor virtual D-7
 capacitors
 about D-4
 AC frequency model D-7
 DC model D-5
 equations D-5
 RF M-1
 time-domain model D-5
 clock C-7
 coil, types of N-2
 comparator
 about G-9
 parameters and defaults G-10
 COMS components
 TinyLogic_2V P-2
 connecting
 ammeter J-2
 voltmeter J-2
 connectors D-1
 control functions
 current limiter block (*see also* current limiter
 block) L-16
 differentiator (*see also* differentiator) L-9
 divider (*see also* divider) L-3
 integrator (*see also* integrator) L-11
 limiter (*see also* limiter) L-15
 multiplier (*see also* multiplier) L-1
 three-way summer L-21
 transfer function block (*see also* transfer
 function block) L-6
 voltage gain block
 voltage hysteresis block L-13
 voltage slew rate block L-20
 voltage-controlled limiter L-19
 controlled one-shot C-23
 coreless coil D-20
 crystal K-1
 current limiter block

- about L-16
- parameters and defaults L-18
- current-controlled current source C-8
- current-controlled voltage source C-7
- customizing
 - nonlinear transformer D-12

D

- Darlington connection
 - about F-8
 - AC model F-9
 - DC bias model F-8
- Data Sel/MUX P-18
- Data Sel/MUX w/3-state Out P-45
- DC bias model F-8
- DC current source C-3
- DC model
 - capacitors D-5
 - diac E-15
 - diodes E-2
 - inductors D-8
 - MOSFET F-12
 - zener diode E-7
- DC voltage source C-2
- Decade Counter P-51, P-80
- depletion MOSFET F-11
- diac
 - about E-14
 - AC small-signal model E-15
 - DC model E-15
 - parameters and defaults E-16
 - time-domain model E-15
- differentiator
 - about L-9
 - equations L-10
 - parameters and defaults L-11
 - sine wave L-9
 - square wave L-9
 - triangle waveform L-9

- digital ground C-2
- diodes E-1
 - AC small-signal model E-4
 - DC model E-2
 - parameters and defaults E-5
 - time-domain model E-3
- Divide-by-twelve Counter P-81
- divider
 - about L-3
 - equations L-5
 - parameters and defaults L-5
- DMOS transistor F-19
- Dual 1-of-4 Dec/DEMUX
 - 4555 O-53
 - 4556 O-53
- Dual 2-to-4 Dec/DEMUX
 - 74xx139 P-14
 - 74xx155 P-20
- Dual 2-to-4 Dec/DEMUX (OC) P-21
- Dual 2-Wide 2-In AND-OR-INVERTER O-34
- Dual 3-In NOR and INVERTER O-3
- Dual 4-bit Binary Counter
 - 74xx393 P-62
 - 74xx69 P-75
- Dual 4-bit latch O-39
- Dual 4-bit latches (clr) P-9
- Dual 4-bit Static Shift Reg O-8
- Dual 4-In AND
 - 4082 O-33
 - 74xx21 P-38
- Dual 4-In NAND
 - 4012 O-6
 - 74xx20 P-38
 - 74xx40 P-64
- Dual 4-In NAND (OC) P-38
- Dual 4-In NOR O-4
- Dual 4-In NOR w/Strobe P-45
- Dual 4-In OR O-29

Dual 4-input Multiplexer O-50
 Dual 4-to-1 Data Sel/MUX
 74xx153 P-19
 74xx352 P-54
 Dual 4-to-1 Data Sel/MUX w/3-state Out
 74xx253 P-46
 74xx353 P-55
 Dual BCD Counter O-46
 Dual Binary Counter O-47
 Dual Com Pair/Inv O-4
 Dual Data Sel/MUX w/3-state Out P-54
 Dual Div-by-2, Div-by-5 Counter P-61
 Dual D-type FF
 (+edge) O-7
 (pre, clr) P-76
 Dual JK FF
 (+edge, pre, clr) 4027 O-19
 (+edge, pre, clr) 74xx109 P-7
 (clr) 74xx107 P-7
 (clr) 74xx73 P-75
 (-edge, pre, clr) P-8
 (-edge, pre, com clk & clr) P-9
 (pre, clr) P-77
 (pre, com clk & clr) P-77
 Dual JK MS-SLV FF (-edge, pre) P-8

E

enhancement MOSFET F-11
 equations
 bipolar junction transistors F-2
 capacitors D-5
 differentiator L-10
 divider L-5
 full-wave bridge rectifier E-10
 GaAsFET F-19
 inductors D-8
 integrator L-12
 limiter L-16
 linear transformer D-11

 multiplier L-3
 relay D-14
 resistors D-4
 three-way summer L-23
 transfer function block L-6
 triode vacuum tube K-5
 voltage gain block L-8
 Exc-3-Gray-to-Decimal Dec P-66
 Exc-3-to-Decimal Dec P-65
 exp. current source C-22
 exp. voltage source C-21

F

FM source. *See* frequency modulated source
 frequency modulated source C-5
 frequency shift key modulated source C-6
 FSK source. *See* frequency shift key modulated source
 full-wave bridge rectifier
 about E-10
 characteristic equation E-10
 model E-10
 parameters and defaults E-11
 functions
 4000 O-3
 4001 O-3
 4002 O-4
 4007 O-4
 4008 O-4
 4010 O-5
 40106 O-5
 4011 O-6
 4012 O-6
 4013 O-7
 4014 O-7
 4015 O-8
 40160 O-9
 40161 O-10
 40162 O-10
 40163 O-10

| | |
|------------|-------------|
| 4017 O-11 | 4077 O-32 |
| 40174 O-12 | 4078 O-32 |
| 40175 O-12 | 4081 O-33 |
| 4018 O-13 | 4082 O-33 |
| 4019 O-14 | 4085 O-34 |
| 40192 O-14 | 4086 O-36 |
| 40193 O-15 | 4093 O-36 |
| 40194 O-15 | 4094 O-37 |
| 40195 O-15 | 4099 O-38 |
| 4020 O-16 | 4502 O-38 |
| 4021 O-16 | 4503 O-39 |
| 4023 O-16 | 4508 O-39 |
| 4024 O-17 | 4510 O-40 |
| 40240 O-18 | 4511 O-41 |
| 40244 O-18 | 4512 O-42 |
| 40245 O-18 | 4514 O-43 |
| 4025 O-19 | 4515 O-44 |
| 4027 O-19 | 4516 O-45 |
| 4028 O-20 | 4518 O-46 |
| 4029 O-21 | 4519 O-47 |
| 4030 O-21 | 4520 O-47 |
| 4032 O-22 | 4522 O-48 |
| 4035 O-22 | 4526 O-48 |
| 40373 O-23 | 4531 O-48 |
| 40374 O-24 | 4532 O-49 |
| 4038 O-24 | 4539 O-50 |
| 4040 O-24 | 4543 O-50 |
| 4041 O-25 | 4544 O-52 |
| 4042 O-25 | 4555 O-53 |
| 4043 O-26 | 4556 O-53 |
| 4044 O-26 | 4585 O-54 |
| 4049 O-26 | 74xx00 P-2 |
| 4050 O-27 | 74xx02 P-3 |
| 4066 O-27 | 74xx03 P-3 |
| 4068 O-28 | 74xx04 P-3 |
| 4069 O-28 | 74xx05 P-4 |
| 4070 O-28 | 74xx06 P-4 |
| 4071 O-29 | 74xx07 P-5 |
| 4072 O-29 | 74xx08 P-5 |
| 4073 O-30 | 74xx09 P-5 |
| 4075 O-31 | 74xx10 P-6 |
| 4076 O-31 | 74xx100 P-6 |

| | | | |
|---------|------|---------|------|
| 74xx107 | P-7 | 74xx173 | P-29 |
| 74xx109 | P-7 | 74xx174 | P-29 |
| 74xx11 | P-7 | 74xx175 | P-30 |
| 74xx112 | P-8 | 74xx180 | P-30 |
| 74xx113 | P-8 | 74xx181 | P-31 |
| 74xx114 | P-9 | 74xx182 | P-31 |
| 74xx116 | P-9 | 74xx190 | P-33 |
| 74xx12 | P-10 | 74xx191 | P-33 |
| 74xx125 | P-11 | 74xx192 | P-34 |
| 74xx126 | P-11 | 74xx193 | P-34 |
| 74xx132 | P-11 | 74xx194 | P-35 |
| 74xx133 | P-12 | 74xx195 | P-35 |
| 74xx134 | P-12 | 74xx198 | P-36 |
| 74xx135 | P-13 | 74xx199 | P-37 |
| 74xx136 | P-13 | 74xx20 | P-38 |
| 74xx138 | P-13 | 74xx21 | P-38 |
| 74xx139 | P-14 | 74xx22 | P-38 |
| 74xx14 | P-14 | 74xx238 | P-39 |
| 74xx145 | P-15 | 74xx240 | P-39 |
| 74xx147 | P-16 | 74xx241 | P-40 |
| 74xx148 | P-16 | 74xx244 | P-40 |
| 74xx15 | P-17 | 74xx246 | P-41 |
| 74xx150 | P-17 | 74xx247 | P-42 |
| 74xx151 | P-18 | 74xx248 | P-43 |
| 74xx152 | P-18 | 74xx249 | P-44 |
| 74xx153 | P-19 | 74xx25 | P-45 |
| 74xx154 | P-19 | 74xx251 | P-45 |
| 74xx155 | P-20 | 74xx253 | P-46 |
| 74xx156 | P-21 | 74xx257 | P-46 |
| 74xx157 | P-21 | 74xx258 | P-47 |
| 74xx158 | P-21 | 74xx259 | P-47 |
| 74xx159 | P-22 | 74xx26 | P-47 |
| 74xx16 | P-23 | 74xx266 | P-48 |
| 74xx160 | P-23 | 74xx27 | P-48 |
| 74xx161 | P-24 | 74xx273 | P-49 |
| 74xx162 | P-25 | 74xx279 | P-49 |
| 74xx163 | P-25 | 74xx28 | P-50 |
| 74xx164 | P-26 | 74xx280 | P-50 |
| 74xx165 | P-27 | 74xx283 | P-50 |
| 74xx166 | P-27 | 74xx290 | P-51 |
| 74xx169 | P-28 | 74xx293 | P-51 |
| 74xx17 | P-28 | 74xx298 | P-51 |

74xx30 P-52
74xx32 P-52
74xx33 P-53
74xx350 P-53
74xx351 P-54
74xx352 P-54
74xx353 P-55
74xx365 P-55
74xx366 P-56
74xx367 P-56
74xx368 P-57
74xx37 P-57
74xx373 P-58
74xx374 P-58
74xx375 P-59
74xx377 P-59
74xx378 P-59
74xx379 P-60
74xx38 P-60
74xx39 P-60
74xx390 P-61
74xx393 P-62
74xx395 P-63
74xx40 P-64
74xx42 P-64
74xx43 P-65
74xx44 P-66
74xx445 P-67
74xx45 P-68
74xx46 P-69
74xx465 P-70
74xx466 P-71
74xx47 P-71
74xx48 P-73
74xx51 P-74
74xx54 P-74
74xx55 P-74
74xx69 P-75
74xx72 P-75
74xx73 P-75
74xx74 P-76
74xx75 P-76

74xx76 P-77
74xx77 P-77
74xx78 P-77
74xx82 P-78
74xx83 P-79
74xx85 P-79
74xx86 P-80
74xx90 P-80
74xx91 P-80
74xx92 P-81
74xx93 P-82

fuse K-14

G

GaAsFET

about F-19

equations F-19

parameters and defaults F-21

gain. *See* voltage gain block

general-purpose high-current N-P-N transistor array F-10

general-purpose P-N-P transistor array F-10

generator

sine wave C-9

square wave C-7

triangle wave C-13

ground C-1

H

Hex BUFFER

4010 O-5

4050 O-27

Hex BUFFER (OC)

74xx07 P-5

74xx17 P-28

Hex Buffer/Driver w/3-state

74xx365 P-55

74xx367 P-56

hex display

- about J-4
- Hex D-type
 - Flip-flop O-12
- Hex D-type FF
 - (clr) P-29
 - w/en P-59
- Hex INVERTER
 - (OC) 74xx05 P-4
 - (OC) 74xx16 P-23
 - (Schmitt) 40106 O-5
 - (Schmitt) 74xx14 P-14
 - 4049 O-26
 - 4069 O-28
 - 74xx04 P-3
 - Buffer/Driver w/3-state, 74xx366 P-56
 - Buffer/Driver w/3-state, 74xx368 P-57
- Hex INVERTER (OC) P-4
- hysteresis block
 - about L-13
 - parameters and defaults L-14

I

- IBEW components
 - coils N-2
 - output devices N-2
 - pilot lights N-3
 - protection devices N-2
 - relays N-2
 - switches D-1
 - timed contacts N-2
- IEEE standard 1076 A-1
- IEEE standard 1076.3 A-24
- IEEE standard 1076.3 (numeric standard) A-2
- IEEE standard 1076.4 (VITAL) A-2
- IEEE standard 1164 A-1
- IGBT-IGBT F-21
- inductor virtual D-10
- inductors
 - about D-7

- AC frequency model D-10
- DC model D-8
- equations D-8
- time-domain model D-9
- instruments
 - ammeter J-2
 - bargraph J-6
 - buzzer J-7
 - hex display J-4
 - lamp J-3
 - probe J-3
 - voltmeter J-1
- integrator
 - about L-11
 - equations L-12
 - parameters and defaults L-13

J

- JFET_N F-15

L

- lamp
 - about J-3
- LED
 - about E-8
 - parameters and defaults E-9
- limiter
 - about L-15
 - equations L-16
 - parameters and defaults L-16
- line transformer N-1
- linear transformer
 - about D-10
 - equations D-11
 - parameters and defaults D-11
- Look-ahead Carry GEN P-31
- lossless line type 1 K-17
- lossless line type 2 K-18
- Lossless transmission line

parameters and default values K-18
lossy transmission line K-15

M

magnetic core D-18
magnetic relay D-13
misc. digital components
 line driver H-9
 line receiver H-9
 line transceiver H-9
 VHDL H-6
mode
 ammeter J-2
 voltmeter J-1
model
 full-wave bridge rectifier E-10
 relay D-14
 SCR E-13
 triode vacuum tube K-5
model parameters
 opamps G-1
mono stable I-3
MOSFET
 about F-10
 AC small-signal model F-13
 DC model F-12
 depletion F-11
 enhancement F-11
 parameters and defaults F-14
 time-domain model F-13
motor K-2
multiplier
 about L-1
 equations L-3
 parameters and defaults L-3

N

net K-18
nonlinear dependent source C-22

nonlinear transformer
 about D-12
 customizing D-12
 parameters and defaults D-13
Norton opamps G-8
N-P-N/P-N-P transistor array F-10

O

Octal BUFFER w/3-state Out P-40
 74xx240 P-39
 74xx244 P-40
 74xx465 P-70
 74xx466 P-71
Octal Bus Transceiver O-18
Octal D-type
 FF P-49
 FF (+edge) P-58
 FF w/en P-59
 Flip-flop O-24
 Transparent Latches P-58
Octal Inv Buffer O-18
Octal Non-inv Buffer O-18
Octal Trans Latch O-23
opamps
 3-terminal
 about G-3
 5-terminal
 interstage G-7
 output stage G-7
 about G-1
 ideal model G-1
 model parameters G-1
optocoupler K-4
oscillator
 voltage-controlled sine wave C-8
 voltage-controlled square wave C-10
 voltage-controlled triangle wave C-12
output device, types of N-2

P

Parallel-load 8-bit Shift Reg

74xx165 P-27

74xx166 P-27

parameters and defaults

bipolar junction transistors F-6

comparator G-10

current limiter block L-18

diac E-16

differentiator L-11

diodes E-5

divider L-5

full-wave bridge rectifier E-11

GaAsFET F-21

integrator L-13

LED E-9

limiter L-16

linear transformer D-11

MOSFET F-14

multipliers L-3

nonlinear transformer D-13

opamps G-1

SCR E-14

three-way summer L-23

transfer function block L-7

triode vacuum tube K-6

voltage gain block L-8

voltage hysteresis block L-14

voltage slew rate block L-21

voltage-controlled limiter L-20

zener diode E-8

passive components

capacitors (*see also* capacitors) D-4

crystal K-1

inductors (*see also* inductors) D-7

linear transformer (*see also* linear transformer) D-10

nonlinear transformer (*see also* nonlinear transformer) D-12

relay (*see also* relay) D-13

resistors (*see also* resistors) D-2

piecewise linear current source C-18

piecewise linear voltage source C-15

pilot light, types of N-3

PIN diode E-6

PLL I-4

polynomial source C-20

potentiometer C-9, D-17

probe

about J-3

protection device, types of N-2

pullup D-18

pulse current source C-20

pulse voltage source C-18

push button switch N-3

PWL source. *See* piecewise linear source

Q

Quad 2-In AND

(OC) 74xx09 P-5

4081 O-33

74xx08 P-5

Quad 2-in Exc-OR gate P-13

Quad 2-In MUX O-14, P-51

Quad 2-In NAND

(Ls-OC) 74xx03 P-3

(OC) 74xx26 P-47

(OC) 74xx38 P-60

(OC) 74xx39 P-60

(Schmitt) 4093 O-36

(Schmitt) 74xx132 P-11

4011 O-6

74xx00 P-2

74xx37 P-57

Quad 2-In NOR

(OC) 74xx33 P-53

4001 O-3

74xx02 P-3

74xx28 P-50

Quad 2-In OR
 4071 O-29
 74xx32 P-52
 Quad 2-In XNOR
 (OC) 74xx266 P-48
 4077 O-32
 Quad 2-In XOR
 4030 O-21
 4070 O-28
 74xx86 P-80
 Quad 2-to-1 Data Sel/MUX P-21
 Quad 2-to-1 line Data Sel/MUX
 74xx257 P-46
 74xx258 P-47
 Quad Analog Switches O-27
 Quad bus BUFFER w/3-state Out P-11
 Quad D-latch O-25
 Quad D-type
 FF (clr) P-30
 FF w/en P-60
 Flip-flop O-12
 Reg w/3-state Out O-31
 Quad Ex-OR/NOR Gate P-13
 Quad Multiplexer O-47
 Quad RS latch w/3-state Out O-26
 Quad SR latches P-49
 Quad True/Complement BUFFER O-25

R

relay
 about D-13
 equations D-14
 model D-14
 types of N-2
 resistance
 about D-3
 ammeter J-2
 voltmeter J-1
 resistors

 about D-2
 equations D-4
 virtual D-4
 RF BJT_NPN M-2
 RF capacitor M-1
 RF inductor M-1
 RF MOS_3TDN M-2
 rpack D-18

S

Schottky diode E-12
 SCR
 about E-12
 AC small-signal model E-14
 model E-13
 parameters and defaults E-14
 time-domain model E-13
 sensing switches N-1
 sine wave L-9
 sine wave generator C-9
 source
 AC current C-4
 AC voltage C-3
 amplitude modulation C-4
 current-controlled current C-8
 current-controlled voltage C-7
 DC current C-3
 DC voltage C-2
 exp. current C-22
 exp. voltage C-21
 frequency modulated C-5
 frequency shift key modulated C-6
 nonlinear dependent C-22
 piecewise linear current C-18
 piecewise linear voltage source C-15
 polynomial C-20
 pulse current C-20
 pulse voltage C-18
 Vcc voltage C-3
 voltage-controlled current C-8

- voltage-controlled piecewise linear C-14
- voltage-controlled voltage C-7
- square wave L-9
- square wave generator C-7
- strip line M-3
- Strobed hex INVERTER O-38
- summer, three-way L-21
- switch
 - push button N-3
 - types of D-1
- Sync 4-bit Bin Counter P-24
- Sync 4-bit Bin Up/down Counter P-34
- Sync 4-bit Binary Counter P-25
- Sync 4-bit Decade Counter P-25
- Sync 4-bit Decade Counter (clr) P-23
- Sync 4-bit up/down Binary Counter P-28
- Sync 4-bit up/down Counter P-33
- Sync BCD Up/down Counter P-33, P-34

T

- terminal, types of N-3
- three-way summer
 - about L-21
 - equations L-23
 - parameters and defaults L-23
- timed contact, types of N-2
- time-domain model
 - bipolar junction transistors F-4
 - capacitors D-5
 - diac E-15
 - diodes E-3
 - inductors D-9
 - MOSFET F-13
 - SCR E-13
- timer I-3
- transfer function block
 - about L-6
 - equations L-6

- parameters and defaults L-7
- transformer
 - linear D-10
 - nonlinear D-12
- Tri 3-In AND
 - 4073 O-30
 - 74xx11 P-7
- Tri 3-In NAND
 - (OC) 74xx12 P-10
 - 4023 O-16
 - 74xx10 P-6
- Tri 3-In NOR
 - 4025 O-19
 - 74xx27 P-48
- Tri 3-In OR O-31
- triac E-16
- triangle wave generator C-13
- triangle waveform L-9
- triode vacuum tube
 - about K-4
 - equations K-5
 - model K-5
 - parameters and defaults K-6
- Triple Serial Adder
 - 4032 O-22
 - 4038 O-24
- Tri-state hex BUFFER w/Strobe O-39
- TTL components P-1
- tunnel diode M-3

V

- varactor diode E-18
- variable capacitor D-15
- variable inductor D-16
- Vcc voltage source C-3
- Verilog HDL
 - extensions B.2-1
 - menus B.3-1

- primer B.1-1
- VHDL
 - examples A-23
 - sample circuits A-3
 - standards history A-1
- voltage
 - gain C-7
- voltage differentiator. *See* differentiator
- voltage gain block
 - about L-7
 - equations L-8
 - parameters and defaults L-8
- voltage hysteresis block
 - about L-13
 - parameters and defaults L-14
- voltage integrator. *See* integrator
- voltage limiter. *See* limiter
- voltage reference K-6
- voltage regulator K-7
- voltage slew rate block
 - about L-20
 - parameters and defaults L-21
- voltage suppressor K-8
- voltage-controlled analog I-2
- voltage-controlled current source C-8
- voltage-controlled limiter
 - about L-19
 - parameters and defaults L-20
- voltage-controlled piecewise linear source C-14
- voltage-controlled sine wave oscillator C-8
- voltage-controlled square wave oscillator C-10
- voltage-controlled triangle wave oscillator C-12
- voltage-controlled voltage source C-7
- voltmeter
 - about J-1
 - connecting J-2
 - mode J-1

- resistance J-1

W

- wide bandwidth amplifiers G-11

Z

- zener diode
 - about E-6
 - DC model E-7
 - parameters and defaults E-8