

User's Guide

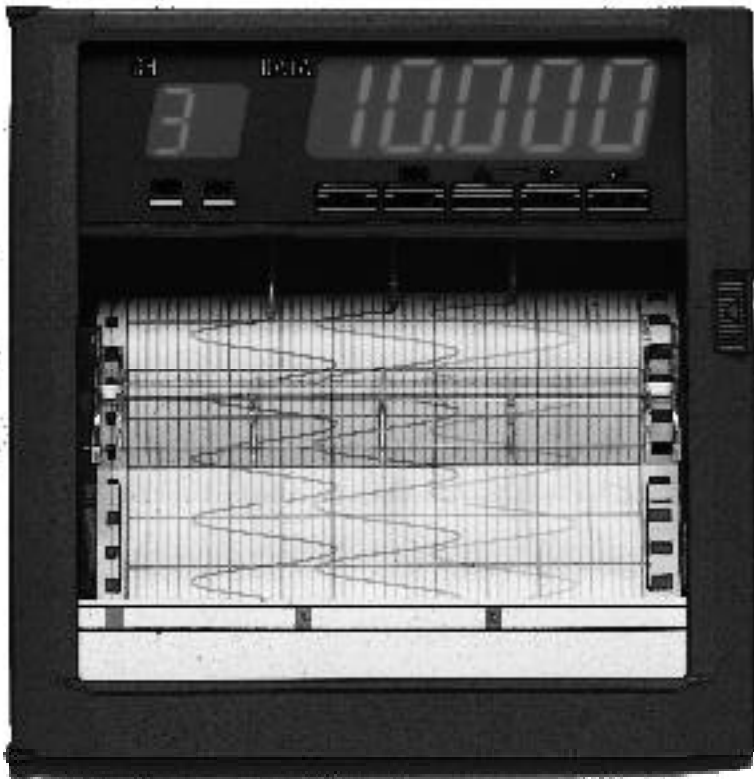

omega.com[®]
CEOMEGA[®]

http://www.omega.com
e-mail: info@omega.com

RD260 RECORDER Technical Manual



OMEGAnet® On-Line Service
<http://www.omega.com>

Internet e-mail
info@omega.com

Servicing North America:

USA:

ISO 9001 Certified

One Omega Drive, Box 4047
Stamford, CT 06907-0047
Tel: (203) 359-1660
e-mail: info@omega.com

FAX: (203) 359-7700

Canada:

976 Bergar
Laval (Quebec) H7L 5A1
Tel: (514) 856-6928
e-mail: info@omega.ca

FAX: (514) 856-6886

For immediate technical or application assistance:

USA and Canada: Sales Service: 1-800-826-6342 / 1-800-TC-OMEGASM
Customer Service: 1-800-622-2378 / 1-800-622-BESTSM
Engineering Service: 1-800-872-9436 / 1-800-USA-WHENSM
TELEX: 996404 EASYLINK: 62968934 CABLE: OMEGA

**Mexico and
Latin America:**

Tel: (001) 800-826-6342
En Español: (001) 203-359-7803

FAX: (001) 203-359-7807
e-mail: espanol@omega.com

Servicing Europe:

Benelux:

Postbus 8034, 1180 LAAmstelveen, The Netherlands
Tel: (31) 20 6418405
Toll Free in Benelux: 0800 0993344
e-mail: nl@omega.com

FAX: (31) 20 6434643

Czech Republic:

ul. Rude armady 1868, 733 01 Karvina-Hranice
Tel: 420 (69) 6311899
Toll Free: 0800-1-66342
e-mail: czech@omega.com

FAX: 420 (69) 6311114

France:

9, rue Denis Papin, 78190 Trappes
Tel: (33) 130-621-400
Toll Free in France: 0800-4-06342
e-mail: france@omega.com

FAX: (33) 130-699-120

Germany/Austria:

Daimlerstrasse 26, D-75392 Deckenpfronn, Germany
Tel: 49 (07056) 3017
Toll Free in Germany: 0130 11 21 66
e-mail: info@omega.de

FAX: 49 (07056) 8540

United Kingdom:

ISO 9002 Certified

One Omega Drive, River Bend Technology Centre
Northbank, Irlam, Manchester
M44 5EX, United Kingdom
Tel: +44 (0) 161 777-6611
Toll Free in United Kingdom: 0800-488-488
e-mail: info@omega.co.uk

FAX: +44 (0) 161 777-6622

It is the policy of OMEGA to comply with all worldwide safety and EMC/EMI regulations that apply. OMEGA is constantly pursuing certification of its products to the European New Approach Directives. OMEGA will add the CE mark to every appropriate device upon certification.

The information contained in this document is believed to be correct, but OMEGA Engineering, Inc. accepts no liability for any errors it contains, and reserves the right to alter specifications without notice.

WARNING: These products are not designed for use in, and should not be used for, patient-connected applications.

Notes

- The contents of this manual are subject to change without prior notice as a result of improvements in the instrument's performance and functions. Display contents illustrated in this manual may differ slightly from what actually appears on your screen.
- Every effort has been made in the preparation of this manual to ensure the accuracy of its contents. However, should you have any questions or find any errors, please contact OMEGA Engineering.

SAFETY PRECAUTIONS

This recorder is developed to satisfy and to be used under the following conditions:

- It is a component type instrument to be installed on an instrumentation panel or rack.
- It complies with the IEC class II safety standard.
- It complies with the EN61010-1 safety standard.
- It complies with the CSA1010-1 safety standard.
- It is based on EN55011 (EMI) Group 1, Class A (for commercial and industrial use).
- It complies with the EN50082-2 (EMS) safety standard.

General definitions of safety symbols used on the recorder and in this manual:

Make sure to comply with the following safety precautions. Not complying might result in injury, death of personnel, or cause damage to the instrument. We assume no liability for customer's failure to comply with these requirements.



Where this mark is found on the recorder there is danger of injury or death. Please check the manual carefully



In-position of bistable push control



Out-position of bistable push control



Power ON



Alternating current



Power OFF



Functional earth terminal (This terminal should not be used as a "Protective earth terminal".)



Equipment protected throughout by double insulation or reinforced insulation (Class II)

WARNING

Power Supply

Ensure the source voltage matches the voltage of the power supply before turning ON the power.

Grounding

Make sure to ground the recorder before turning on the power.

Necessity of Grounding

Grounding is necessary to prevent noise interference.

Do not Operate in an Explosive Atmosphere

Do not operate the recorder in the presence of flammable liquids or vapors.

Operation of any electrical instrument in such an environment constitutes a safety hazard.

Keep Away from Live Circuits

Inside this recorder there are areas of high voltage; therefore, never touch the interior when the power supply is connected. The recorder has replaceable parts and subassemblies; however, the replacement must be carried out only by our service personnel.

External Connection

Before connecting to measurement and control unit, connect the grounding wire.

Using the Technical Manual

This manual contains information about the instrument's functions and operating procedures as well as precautions that should be observed during use. To ensure proper use of the instrument, please read this manual thoroughly before operating it. Keep the manual in a safe place for quick reference whenever a question arises.

Two manuals are provided with the instrument, including this Technical Manual.

Manual Name	Description
User's Manual	Basic information for recorder operators.
Technical Manual	Detailed technical manual for recorder engineers, including mounting, wiring and setting information. Read this manual first.

Structure of this Manual

This Manual is intended for technicians in charge with installing, and wiring, and with the making of the recorder settings.

The additional User's Manual is intended for simple daily operation of the recorder.

Chapter	Title	Content
1	Preparation	Read this before unpacking the recorder. List of accessories and explanation of the basic functions and display. Also describes the mounting and wiring required before use.
2	Regular Settings	Explains the Regular Setting mode mode, in which daily-used settings such as input range, recording span, alarm setpoints, and chart feed speed are made.
3	Basic (SETUP) Settings	Explains the Basic (SETUP) Setting Mode, for the adjustment of a whole range of detailed settings such as the pen's position, dot printing position and color, the noise input filter, a remote trigger settings.
4	Calibration and Adjustment	Explains how to calibrate the recorder and how to adjust pen, dot and ribbon positions.
5	Periodic Inspection	About periodic maintenance and cleaning of the recorder.
6	Troubleshooting	Explains the meaning of error messages on recorder display and a troubleshooting check list.
	Index	

Conventions Used in this Manual

Displayed characters

Bold alphanumeric characters enclosed with [] refer to characters or setting values that are displayed on the screen.

Symbols

The following symbol marks are used to attract the operator's attention.



Affixed to the instrument. Indicates danger to personnel or instrument and the operator must refer to the User's Manual. ThinUser's Manual to indicate the reference.

WARNING

Describes precautions that should be observed to prevent injury or death to the user.

CAUTION

Describes precautions that should be observed to prevent minor or moderate injury, or damage to the instrument.

Note

Provides important information for the proper operation of the instrument.

Contents

⚠ SAFETY PRECAUTIONS	ii
Using the Technical Manual	iii
Chapter 1 Preparation	1-1
1.1 Checking Accessories and Appearance	1-1
1.2 Removing Packings	1-2
1.3 Checking Model Codes	1-3
1.4 Front/Rear Panels: Functions and Display	1-4
1.5 Handling Precautions	1-6
1.6 Mounting	1-7
⚠ 1.7 Wiring	1-10
Chapter 2 Regular Settings	2-1
2.1 Introduction to Regular Settings	2-1
2.2 Setting Input Range and Recording Span	2-3
2.3 Setting Alarm Functions	2-8
2.4 Adjusting the Chart Speed	2-10
2.5 Setting the Dot Printing Interval (Dot Model)	2-11
2.6 Setting the Key-Lock	2-12
Chapter 3 Basic (SETUP) Settings	3-1
3.1 Introduction to Basic (SETUP) Settings	3-1
3.2 Setting Relay for post-Alarm (de-)Energizing	3-4
3.3 Setting Alarm Hysteresis	3-5
3.4 Selecting A/D Integration Time (Pen Model)	3-6
3.5 TC Burnout Registration Method	3-7
3.6 Setting the Noise Input Filter (Pen Model)	3-8
3.7 Setting Moving Average Calculation (Dot Model)	3-9
3.8 Offset Values	3-10
3.9 Assigning Channel Printing Colors (Dot Model)	3-12
3.10 Selecting Celsius or Fahrenheit	3-13
3.11 Remote Trigger for Recording or Chart Speed	3-14
3.12 Protecting Settings	3-15
3.13 Initializing Settings	3-16
Chapter 4 Calibration and Adjustment	4-1
4.1 Calibration	4-1
4.2 Re-adjusting the Pen-Position (Pen Model)	4-3
4.3 Re-adjusting the Dot-Position (Dot Model)	4-5
Chapter 5 Periodic Inspection	5-1
5.1 Periodic Inspection	5-1
Chapter 6 Troubleshooting	6-1
6.1 Error Messages	6-1
6.2 Troubleshooting	6-2
Index	Index-1

1.1 Checking Accessories and Appearance

Checking and Unpacking

This recorder has been thoroughly inspected before shipment; however, when you receive the recorder, check that all accessories are present and in the correct quantities. Also check the external appearance of the recorder to ascertain that no damage has occurred.

Checking Accessories and Appearance

The recorder should be accompanied by the accessories indicated below. Check that all are present in the correct quantities. Also check the external appearance of the recorder to ascertain that no damage has occurred.

Accessories

No.	Name	Quantity	Remarks
1	Disposable felt pen		Only for pen models
	1-pen model	1	Red
	2-pen model	2	Red, green
	3-pen model	3	Red, green, blue
2	Ribbon cassette	1	Only for dot model
3	Mounting brackets	2	
4	Z-folded chart paper	1	Approx. 16 meter
5	Instruction manuals	2	1 User's Manual & 1 Technical Manual

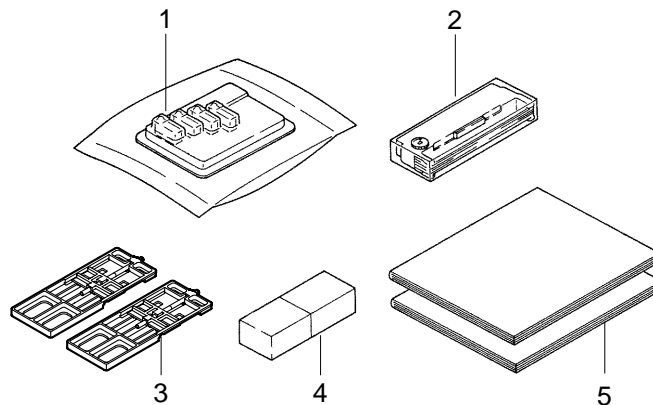

Spare Parts

Name	Part No.	Quantity*	Remarks
Disposable felt pen (red)	RD260-01	3	Only for pen models
Disposable felt pen (green)	RD260-02	3	Only for pen models
Disposable felt pen (blue)	RD260-03	3	Only for pen models
Ribbon cassette	RD260-RC	1	Only for dot model
Mounting brackets	B9962CG	2	
Z-folded chart paper	RD260ZFP	10	Approx. 16 meter

*The amount of items per ordered Part No.

1.2 Removing Packings

The internal assembly is secured in position by packings to safeguard against damages during transit. Before you unpack the recorder please read the following.

Opening the front door

Open the front door by pushing and then pulling the clip on the right, as shown below, and open the display by pulling its left end after removing the adhesive tape.

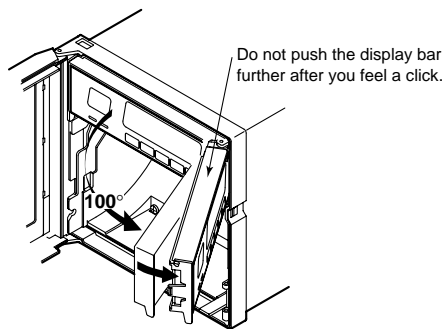
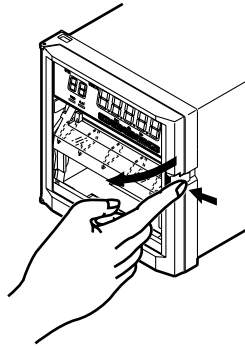

CAUTION

- Please take care not to apply any undue pressure in an upward or downward direction to the display. This might cause a strain on the hinges.

- When you open the display further than about 100 degrees you will feel a clicking resistance which marks the largest possible opening for the display. Do not try to open the display further than upto that point as it may break.

Removing Protective Lock Screw and Packings

Pen model

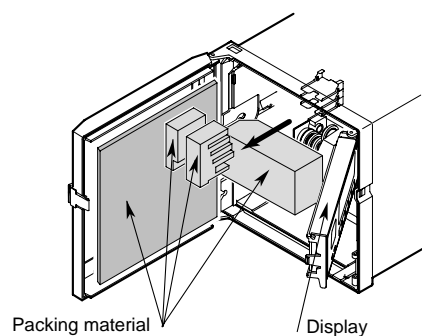

Dot model

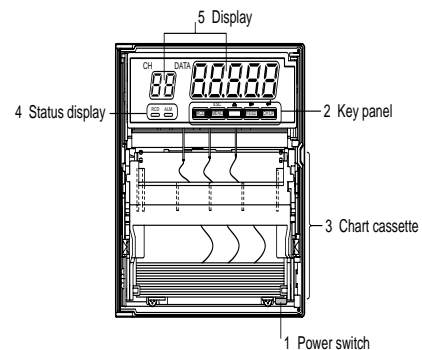

1.3 Checking Model Codes

Check the model codes on the nameplate to make sure they are as specified by your order.

The nameplate is visible after you removed the chart cassette and is as shown in the figure below. When you contact Omega, inform the model code (MODEL) and the serial number (No.).

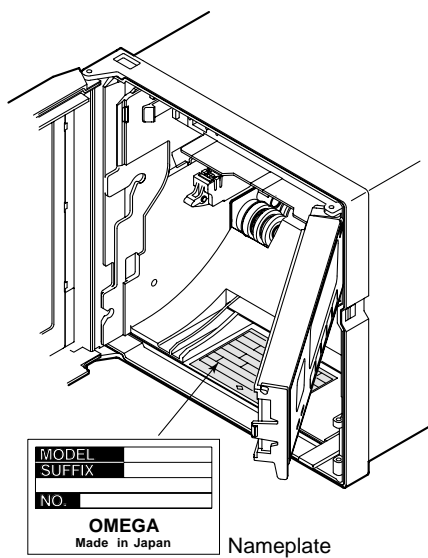

1.4 Front/Rear Panels: Functions and Display

Front Panel

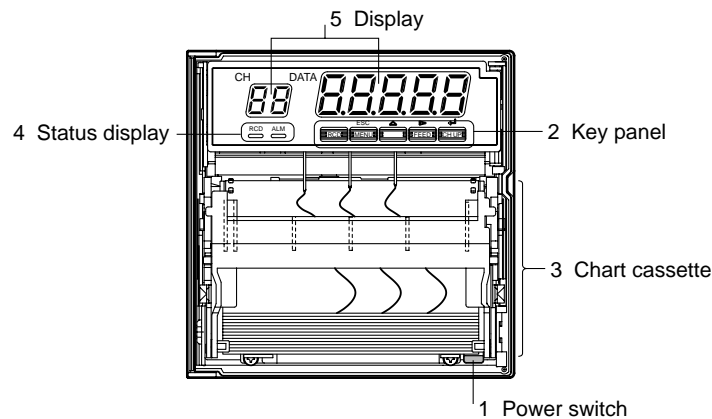

1. Power switch (push-button type)

Pressing the switch turns the power ON and OFF.

2. Key panel (push-key type)

The panel contains the following five keys:



RCD key

Pressing the key starts or stops the recording.



DISP key, ESC key

DISP function: Cycles through the modes of display in the order of AUTO, MANUAL, and OFF. Also selects between the Regular Setting mode and Operation mode (see Section 2.1).

If this key is pressed for three seconds, the recorder enters the Regular Setting Mode.

ESC function: Exits from the menu in the middle of setting or selecting procedures.



△ key

Selects setting parameters (numerics or command codes). Selecting step is upward circulation.

If the recorder is a pen model, pressing this key for three seconds in operation mode causes the recorder to enter the pen-replacement mode.



FEED key, ▷ key

FEED function: The chart is fed as long as this key is being pressed.

▷ key function: Changes the number of digits for setting numeric values. The digit moves from high to low.



CH UP key, ENT key

CH UP function: Selects a channel for which the display shows the screen in the MANUAL display mode.

← function: Makes a parameter entry or executes a function after selecting parameters (numerals or command codes). Pressing the key executes the settings.

3. Chart cassette

Contains a Z-fold chart (width: 100 mm, length: 16 m).

4. Status Display

RCD indicator: Illuminated when recording of measurement values is in progress.
 ALM indicator: Will illuminate when an alarm occurs.

5. Seven-segment character display

Used to display data, setting screen, etc.

- Data display: Displays channel No., type of alarms, and measured data.
- Setting screen: Displays various settings of the recorder.

Characters on Display

The display consists of seven segments, and therefore characters exist which are difficult to display.

Characters are presented on the display as shown in the following table.

Display	A	b	c	d	E	F	G	H	h	I	J	K	L	l
Alphabet	A	B	C	D	E	F	G	H	h	I	J	K	L	l
Display	m	n	o	P	q	r	S	t	U	v	w	X	Y	Z
Alphabet	M	N	O	P	Q	R	S	T	U	V	W	X	Y	Z

Rear Panel

Below, the rear panel of the dot model reorder, for more details and the rear of the pen model recorder see Section 1.7, *Wiring*.

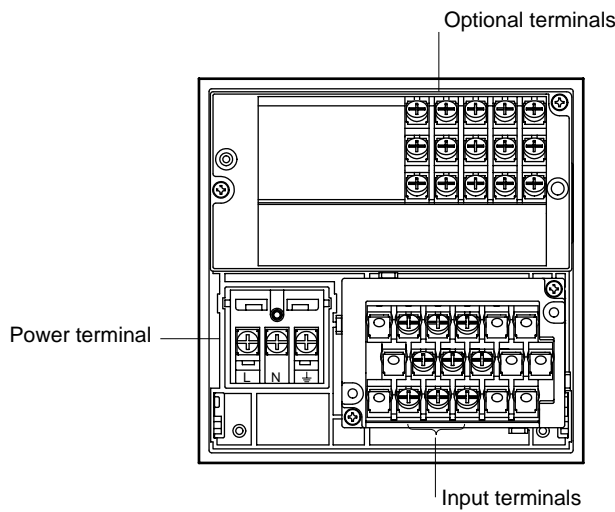

1.5 Handling Precautions

Safety precautions

- Before you use this recorder make sure to read the Safety Precautions on page 2 of this manual.
- Do not touch the interior of this recorder. For the replacement of parts, please contact OMEGA Engineering.
- Turn the recorder power switch off as soon as any symptoms of malfunction such as unusual sound, smell, or smoke yield from the recorder. Also turn the main power switch off. If a malfunction occurs, contact OMEGA Engineering.

General handling precautions

- The recorder contains many plastic parts. To clean, use a soft, dry cloth. Do not use chemicals such as benzene or thinner, since these may cause discoloration or damage.
- Do not bring any objects charged with static electricity near the signal terminals. This might cause malfunction.
- Do not allow any volatile substances to the front or key panel. Do not allow rubber or vinyl to remain in contact with the recorder for long periods.
- Whenever the recorder is not used, turn the power switch OFF.

1.6 Mounting

Installation Site

Before mounting the recorder make sure to read this chapter carefully.

Panel and rack mounting

- The recorder is designed to be installed on an instrumentation panel or rack.

Well ventilated location

- Install the recorder in a well ventilated site to prevent internal overheating.

Avoid mechanical vibration

- To install the recorder in a location susceptible to mechanical vibration will adversely affect the mechanical parts and the quality of recording. Please choose an installation site with minimal mechanical vibration.

Horizontal installation

- The recorder must be installed horizontally from left to right. Backward or forward mounting may slant 0° to 30°.

Avoid direct sunshine or heater radiation.

- The recorder will be adversely affected if the unit is exposed to direct sunlight or installed near a heater. Choose a location near room temperature (23°C) with minimal temperature fluctuation.

Keep out of soot, steam, moisture, dust, corrosive gases

- The recorder will be damaged if exposed to soot, steam, moisture, dust, corrosive gases, etc.,

Avoid electro-magnetic fields

- To use the recorder within strong electro-magnetic fields may cause malfunction. Please avoid installing near electro-magnetic objects.

Mounting Methods

- 1 The recorder has three small square windows lined on the right, left, bottom and top of the recorder to apply mounting brackets. Remove the plastic inside frames of the square windows, as shown in the below illustration, by flipping them out with a small screwdriver. Don't let the frames fall inside.

CAUTION

- Take care not to damage the interior of the recorder when flipping the plastic frames out of the windows. Don't insert the driver too far.

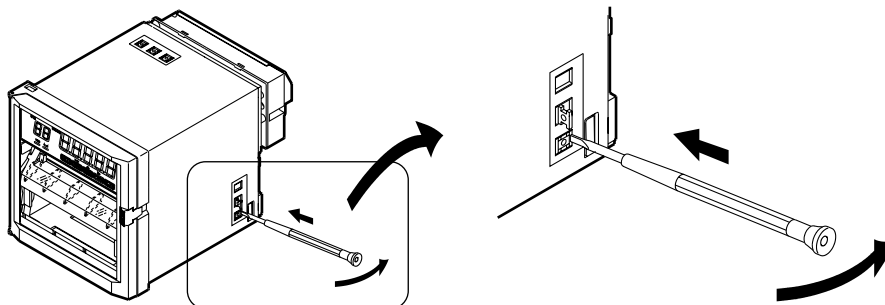

- 2 Insert the recorder into the panel-front face (continued on next page).

3 Mount the recorder on a steel panel which thickness is at least 2 mm (and up to 26 mm).

Fix the recorder to the panel using the mounting brackets as shown in below.

Adequate screw tightening torque is approximately 3 to x kg-cm. A pair of mounting brackets can be applied to the recorder's top and bottom, or to both side faces.

CAUTION

- A tightening torque exceeding the above-mentioned adequate values may cause deformation of the recorder case or brackets.
-

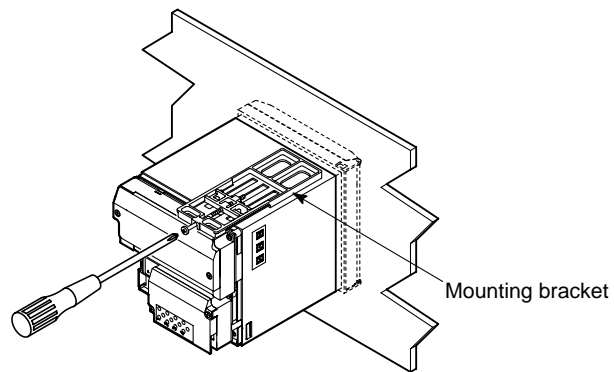

External Dimensions

Panel Cutout and External Dimensions (including Mounting Brackets).

Unit : mm (approx. inch)

If not specified, the tolerance is $\pm 3\%$. When less than 10 mm, however, tolerance is ± 3 mm.

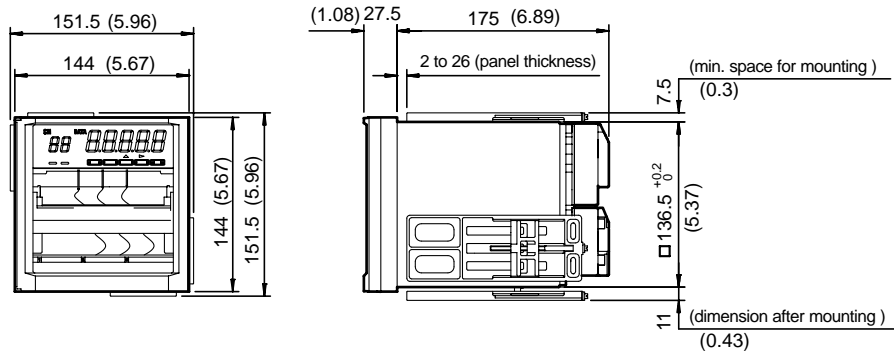

Panel Cutout & Spacing

Single-Unit Mounting

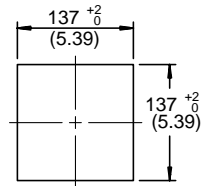

Side-by-Side Mounting (horizontally)

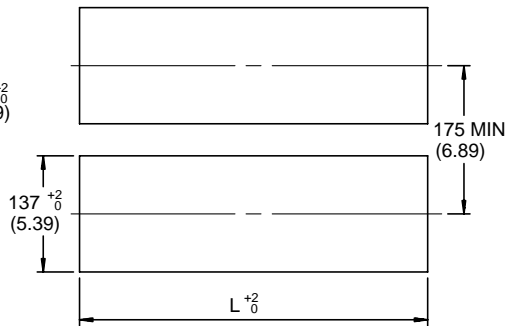

Side-by-Side Mounting (vertically, max. 3 units)

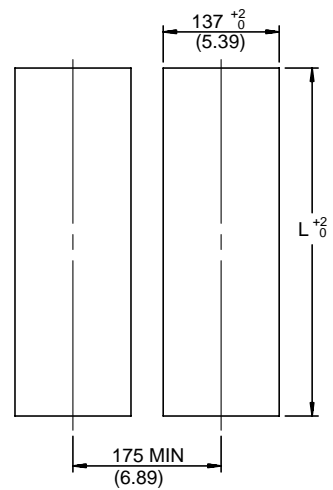

Units	L $\frac{+2}{0}$ (mm)
2	282
3	426
4	570
5	714
6	858
7	1002
8	1146
9	1290
10	1434
n	(144xn)-6

Note

- A pair of mounting brackets should be used on the top and bottom, or on both sides of the recorder.

1.7 Wiring

Wiring should be done only after you have read this section. The section consists of the following subsections:

page:

1-10 Rear Panel Terminal Arrangement

1-11 Power Supply Wiring

1-12 Input Signal Wiring

1-14 Alarm Output Wiring

1-15 Remote Control Wiring



WARNING

- Make sure to fasten the wiring at the rear wall of the mounting panel and employ some kind of strain relief between the rear wall and the recorder to prevent an electric shock.

Rear Panel Terminal Arrangement

Pen Model

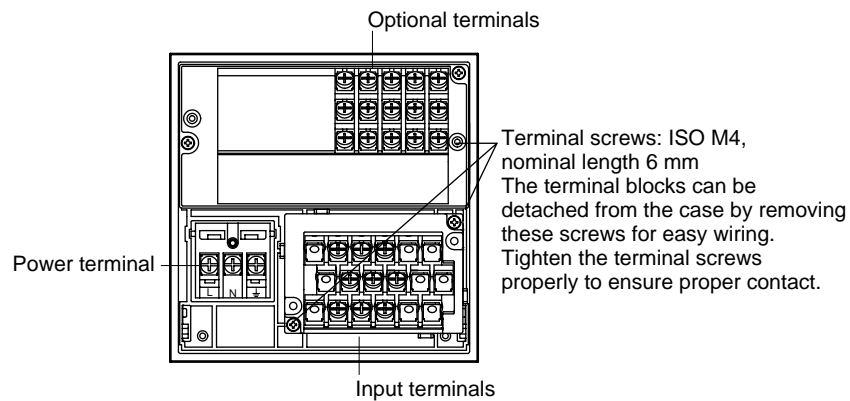

Dot-Printing Model

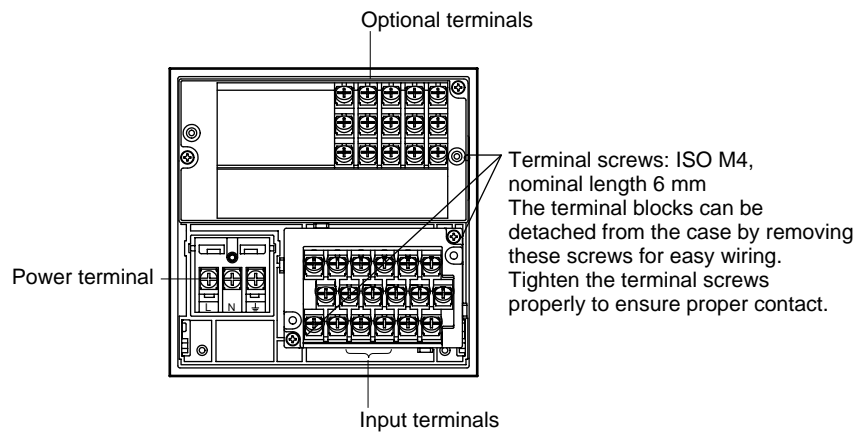

Power Supply Wiring



WARNING

- To prevent an electric shock, ensure the main power supply is turned off before wiring.
- To prevent fire, use 600 V PVC insulated wire (AWG18) for power and ground wiring (cross sectional area of 0.83 mm² or thicker, anti-galvanic corrosion finish, insulation thickness should be more than 0.8 mm, insulation resistance should be more than 50 M Ω·km at 20°C, approved EN60 320 (VDE0625)), or equivalent cables.
- Connect the protective grounding wire to the earth through grounding resistance less than 100 Ω before turning on the power .
- Use crimp on lugs (for 4 mm screws) with insulation sleeves.
- To prevent an electric shock, cover the power terminals certainly with the transparent cover.
- Make sure to apply a power switch with the following characteristic:
 rated power current > 1A
 rated rush current > 60A
 fuse(s) of 2 to 15A

Wiring method

- 1 The rated power supply voltage for the recorder is 100 to 240 V AC.
- 2 Turn the recorder's power switch OFF.
- 3 Open the transparent cover of the power terminal after releasing the cover screw.
- 4 Connect the power supply wires and the protective ground wire to the terminal. To prevent an emission of electromagnetic disturbances, separate the input wires from the other wires at least 0.1 m. Over 0.5 m is recommended.
- 5 Cover the terminals with the transparent cover, and secure the screw.

Power Supply Wiring

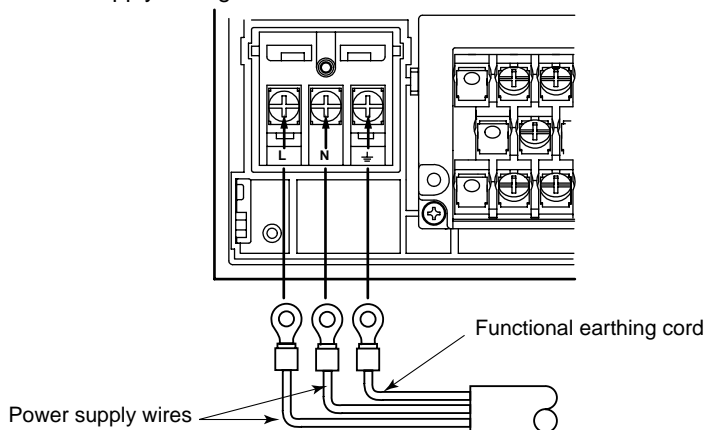

Note

- Do not apply a power supply in the range from 132 V to 180 V AC. Doing so might affect the measuring accuracy.
- To prevent emission of electromagnetic disturbances, separate the power supply wires from the other wires at least 0.1 m. Over 0.5 m is recommended.

Input Signal Wiring



WARNING

To prevent an electric shock, ensure the main power switch is turned off when wiring.



CAUTION

Do not apply inputs exceeding the rated range as follows to prevent the recorder from damage:

- Maximum input voltage
 - ±10 V DC for TC, and for the voltage range of 2 V DC or less
 - ±30 V DC for the voltage range of 6 to 20 V DC
 - Maximum common mode voltage
 - 250 V AC rms (50/60 Hz)
 - This instrument complies with Installation Category II.
-

- 1 Turn off the recorder power switch.
- 2 Remove the transparent cover for the input signal terminals.
- 3 Connect the input signal wires to the terminals. To prevent an emission of electromagnetic disturbances, separate the input wires from the other wires at least 0.1 m. Over 0.5 m is recommended.
- 4 Attach the cover on the terminals, and secure the screws.

It is recommended to use the crimp-on lugs (for 4 mm screws) with insulation sleeves for lead wire ends, but they are not required for thermocouples (TC) .

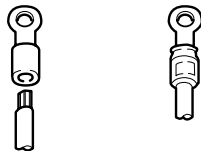

Crimp-On Lugs

Suggestions to minimize noise pickup:

- Separate the measuring-signal wires from power lines and grounding lines.
- It is desirable that the measuring object is not a noise source; if not, insulate it from the measuring signal wires and ground the object.
- It is recommended to use shielded wires to minimize noise pickup from an electrostatic induction source. The shields are connected to the recorder's grounding terminal, if necessary. In that case, avoid two-point grounding.
- To minimize the noise from an electrostatic induction noise, twist the measuring wires (a pair of wires) in short and equal intervals.
- The grounding line must have low resistance.

For TC (thermocouple) inputs the ambient temperature around the recorder's terminal board should be kept as stable as possible.

- Cover the input terminals with the transparent cover.
- Do not use a large-diameter wire (cross sectional area of more than 0.5 mm²) because it has a large radiation rate.
- Keep the ambient temperature as stable as possible; start/stop of a nearby fan can considerably affect the temperature.

If input signal wires are connected to two or more receivers with parallel connection, measured values sometimes affect each other. The following notes should be observed for parallel connection:

- Ground each receiver at the same point.
- Do not turn on/off the power of a receiver while other receivers are in measuring operation.
- A resistance temperature sensor (RTD) cannot be used essentially in parallel connection.

Terminal Board (Pen Model)

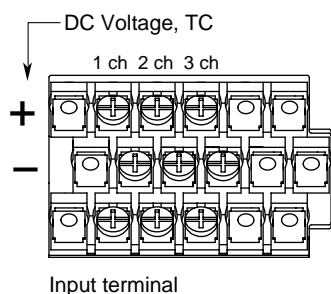

Terminal Board (Dot Model)

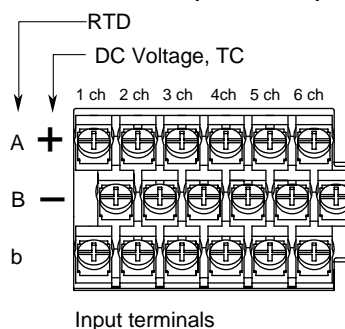

Wiring for Input Terminals

DC voltage Inputs

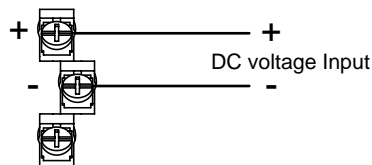

TC input

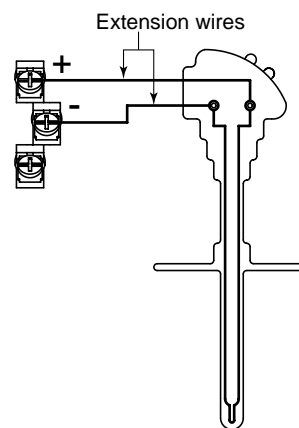

RTD input (for dot model only)

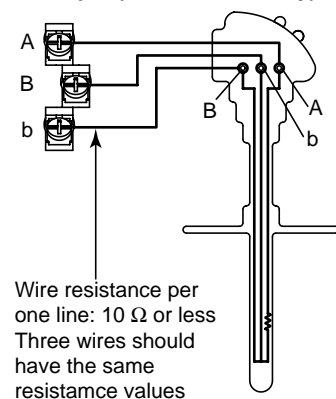

DC current input

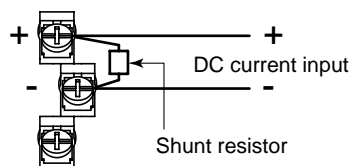

Example: The shunt resistor rating is 250 Ω ± 0.1% for the current input of 4 to 20 mA.

Alarm Output Wiring (optional)



WARNING

To prevent an electric shock, ensure the power switch is turned off before wiring.

Depending on the type (the number of outputs) of alarm relay options, the terminal arrangement changes as shown in the following:

Alarm Output Terminal Arrangements

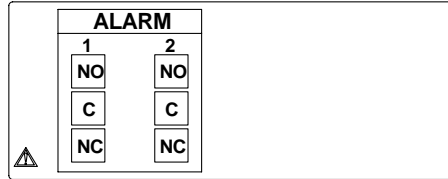

-A2 Option
(2 outputs)

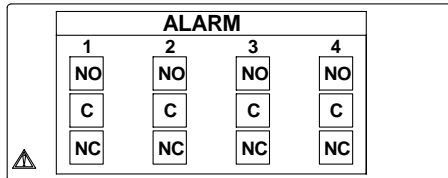

-A4 Option
(4 outputs)

Contact characteristics

- Output type** : Relay transfer contacts
- Output capacity** : 250 V AC (50/60 Hz), 3 A. 250 V DC, 0.1 A (resistive load)
- Dielectric strength** : 1500 V AC (50/60 Hz) for one minute between output terminals and grounding terminals

Wiring method

- 1 Turn the power switch off.
- 2 Remove the transparent cover of the optional terminals.
- 3 Connect the alarm output wires to the optional terminals.
To prevent an emission of electromagnetic disturbances, separate the alarm output wires from the power supply and input wires at least 0.1 m. Over 0.5 m is recommended.
- 4 Cover the terminals with the transparent cover and secure the screws.

Remote Control Wiring (optional)



WARNING

To prevent an electric shock, ensure the power switch is turned off before wiring.

Remote Control Terminals Arrangements:



Input characteristics

Input signal:

Dry contact, open-collector (TTL or transistor) signal.

Control functions and signal types:

- | | |
|--------------------------|-------|
| (1) Recording start/stop | level |
| (2) Chart speed change | level |

Signal characteristics:

- | | |
|------------------------------|--------------------------|
| ON voltage | 0.5 V or less (30 mA DC) |
| Leakage current in OFF state | 0.25 mA or less |
| Signal duration | 250 ms or more |

Input types:

- Photocoupler isolation (one line common).
- Internal isolated power source (5 V \pm 5%).

Dielectric strength:

500 V DC for one minute between input terminals and grounding terminal.

Wiring method

- 1 Turn the power switch off to prevent an electric shock.
- 2 Remove the transparent cover of the optional terminals.
- 3 Connect the wires for remote control to the optional terminals. The C is the terminal common to other 1 to 2. To prevent an emission of electromagnetic disturbances, separate the input wires from the other wires at least 0.1 m. Over 0.5 m is recommended.
- 4 Cover the terminals with the transparent cover and secure the screws.

Note

- Use shielded cables for remote control signals to prevent noise pickup. The shield should be grounded at the recorder's terminal.

2.1 Introduction to Regular Settings

Three Recorder Modes

Operation Mode

This is the mode for daily operation, described in the ; when the power turns on, the recorder automatically enters this mode.

Select from the following functions by pressing the appropriate keys on the key panel.

- △ key Replacement of pens (pen model only). See *User's Manual* Section 2.5.
- RCD key Starting/stopping the recording.
- FEED key Feeding the chart. See *User's Manual* Section 2.1.
- DISP key Selection from the modes on display. See *User's Manual* Section 1.1.

Regular Setting Mode

In the Regular Setting mode, described in this Chapter, daily-used settings such as input range, recording span, alarm setpoints, and chart feed speed are made. Pressing the **DISP** key three seconds in the operation mode changes the mode to the Regular Setting mode.

Basic (SETUP) Setting Mode (see Section 3)

In the Basic (SETUP) Setting Mode, you can adjust a whole range of detailed settings such as the pen's position, dot printing position and color, the noise input filter, and remote trigger settings. Enter this mode by turning the power ON while pressing the **CH UP(ENT)** key.

Note

While in the Basic (SETUP) mode, measurement, recording, and alarm detection are not carried out.

Using the settings protection function, you can protect your settings by defining a password when you enter the Regular or Basic (SETUP) mode.

Turning the Recorder Modes ON

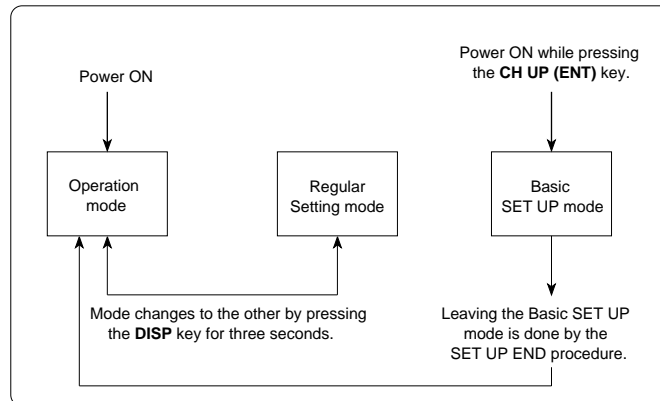

Turning the Recorder Modes OFF

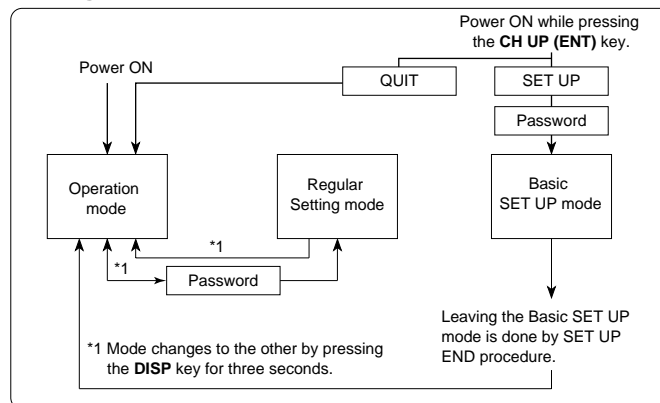

Flow Chart Regular Setting Mode

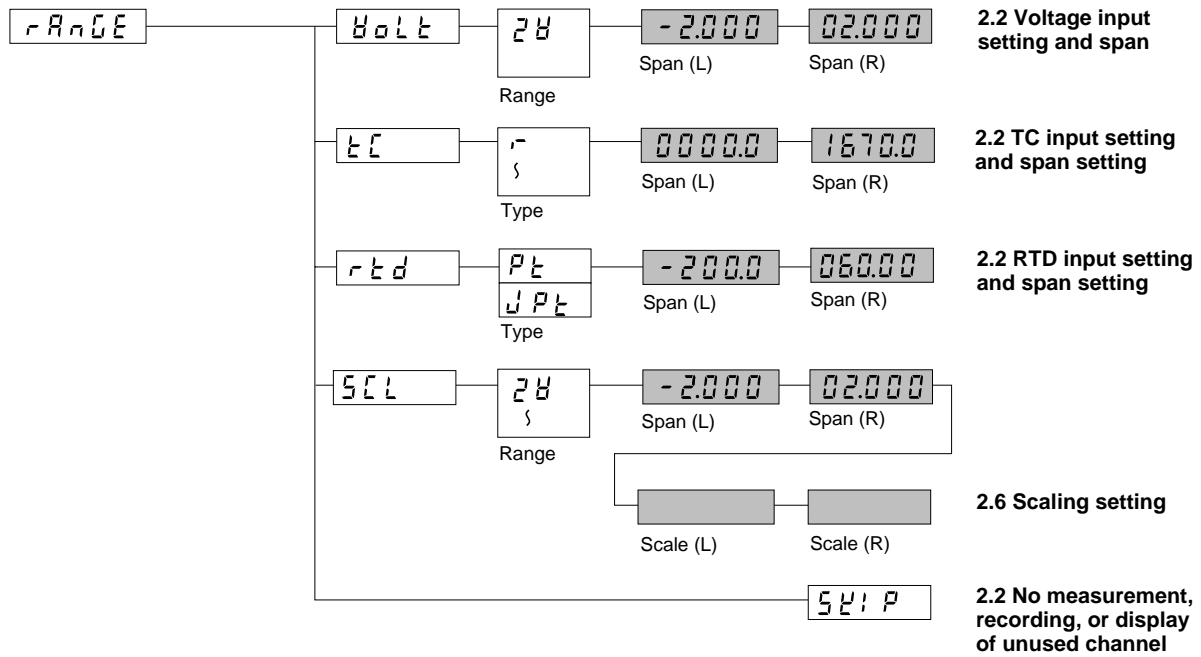

3.8 Offsets (when offset settings protection function is ON only)

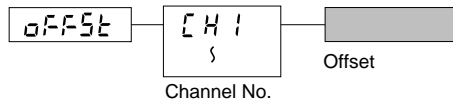

2.3 Alarm functions

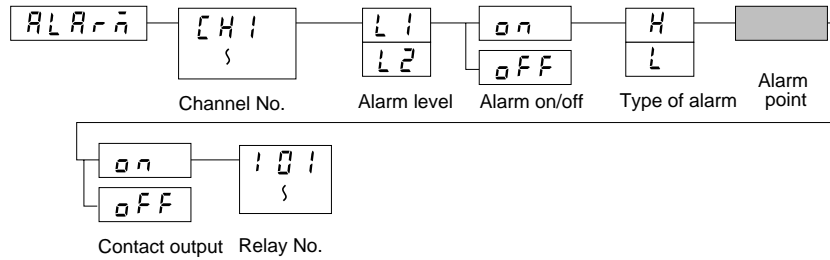

2.4 Chart feed speed

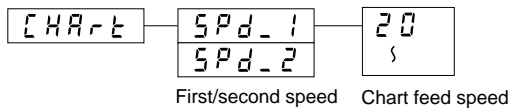

2.5 Dot-printing interval in analog records (dot model)

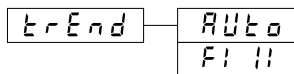

2.6 Key lock

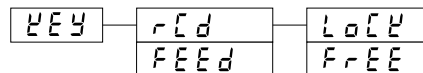

[Grey box] : Numeric value input

2.2 Setting Input Range and Recording Span

Setting Input Range and Recording Span

One of the following parameters can be set for every channel:

SKIP Prevents the specified channel from being measured, recorded and displayed .

VOLT Measures and records DC-voltage.

TC Measures and records temperatures using Thermocouple.

RTD Measures and records temperatures using Resistance Temperature Detector .

SCL Performs scaling on voltage measurements.

Scaling results in appending a different scale to the measured values.

Restrictions apply to the measurable types of input depending on the type of recorder used. Check your recorder type as indicated on the nameplate (see Section 1.3 for details on the nameplate), and then refer to the following table:

Model Code	Measurable Type of Input
RD260	Voltage (VOLT), thermocouple (TC), SCL
RD266-RTD	Resistance temperature detector (RTD, dot-models only)

SKIP Setting

Unused channels can be skipped, which means that these channels will not be measured, recorded or displayed.

Setting Procedures

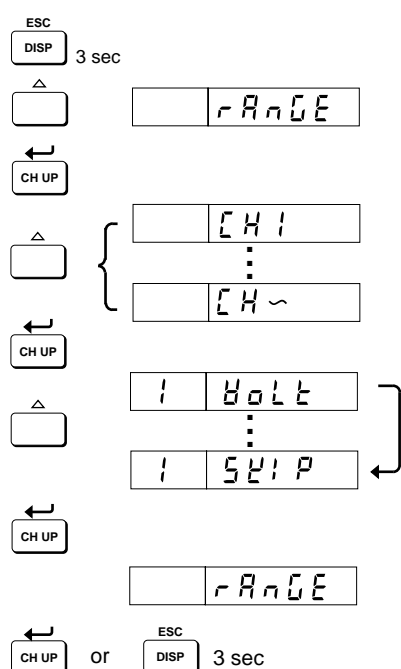

Press the **DISP** key for three seconds to enter the Regular Setting mode.

Select the **[Range]** display by using the Δ key. Then press the **ENT** key.

Use the Δ key to select the desired channel. Press the **ENT** key.

Use the Δ key to select **[Skip]**. Press the **ENT** key.

[Range] is displayed and the setting is completed.

Press the **ENT** key to set another channel; or press the **DISP** key for three seconds to return to the Operation mode.

Voltage Measurement Setting (VOLT Setting)

If the measured signal is a DC-voltage, the range can be set as follows:

Setting Procedures

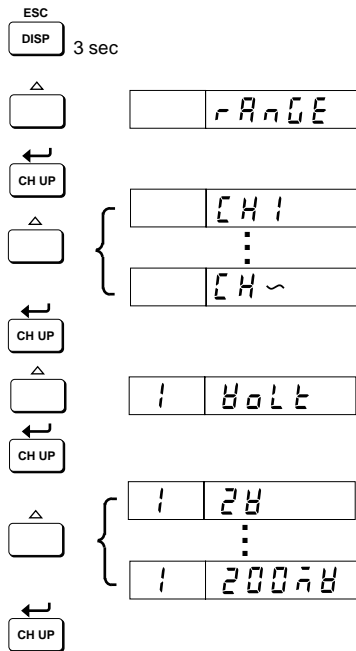

Press the **DISP** key for three seconds to enter the Regular Setting mode.

Select the **[Range]** display by using the \triangle key. Then press the **ENT** key.

Use the \triangle key to select the desired channel. Press the **ENT** key.

Use the \triangle key to select **[Volt]**. Press the **ENT** key.

Select the desired range using the \triangle keys and press the **ENT** key.

Display	Range
20mV	-20.00 to 20.00mV
60mV	-60.00 to 60.00mV
200mV	-200.0 to 200.0mV
2V	-2.000 to 2.000V
6V	-6.000 to 6.000V
20V	-20.00 to 20.00V

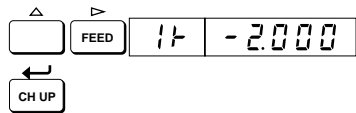

Select the minimum value of the recording span (SPAN L) using the \triangle and \triangleright keys. Then press the **ENT** key.

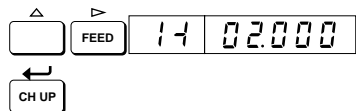

The display which appears will allow you to enter the maximum value of the recording span (SPAN R). Select it the same way as for the minimum value and press the **ENT** key.

The recording span cannot be beyond the input range, nor can SPAN L be equal to SPAN R.

[Range] is displayed and the setting is completed.



Press the **ENT** key to set another channel; or press the **DISP** key for three seconds to return to the Operation mode.

Setting Thermocouple and Resistance Temperature Detector (dot model only)

In the case that the measured signal is a TC (Thermocouple), or -for dot models only- RTD (Resistance Temperature Detector), the range can be set the same way as if it were a DC-voltage.

Setting Procedures

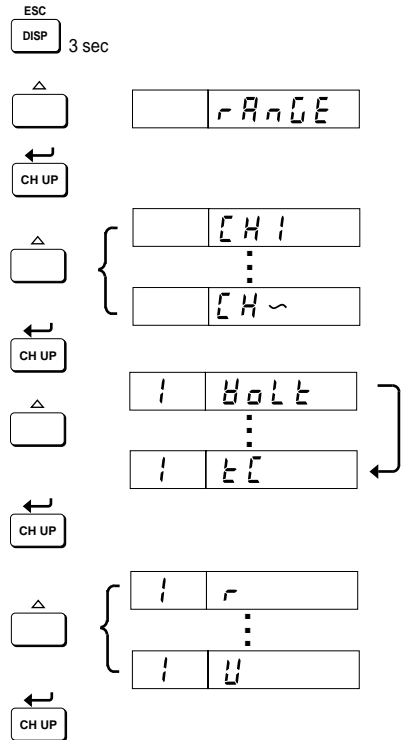

Press the **DISP** key for three seconds to enter the Regular Setting mode.

Select the **[Range]** display by using the \triangle key. Then press the **ENT** key.

Use the \triangle key to select the desired channel. Press the **ENT** key.

Use the \triangle key to select **[TC]**, or **[RTD]**. Press the **ENT** key.

Select the desired type (R, S, B, K, E, J, T, N, W, L, U in case of TC, or PT, JPT in case of RTD) using the \triangle key and press the **ENT** key.

TC Type Description and RTD Type Description

TC Type Description		
	Range	
r (Type R)	0.0 to 1760.0°C	32 to 3200°F
S (Type S)	0.0 to 1760.0°C	32 to 3200°F
b (Type B)	0.0 to 1820.0°C	32 to 3308°F
K (Type K)	-200.0 to 1370.0°C	-328 to 2498.0°F
E (Type E)	-200.0 to 800.0°C	-328.0 to 1472.0°F
J (Type J)	-200.0 to 1100.0°C	-328.0 to 2012.0°F
T (Type T)	-200.0 to 400.0°C	-328.0 to 752.0°F
N (Type N)	0.0 to 1300.0°C	32 to 2372°F
W (Type W)	0.0 to 2315.0°C	32 to 4199°F
L (Fe-CuNi)	-200.0 to 900.0°C	-328.0 to 1652.0°F
U (Cu-CuNi)	-200.0 to 400.0°C	-328.0 to 752.0°F

RTD Type Description		
	Range	
Pt (pt 100 Ω)	-200.0 to 600.0°C	-328.0 to 1112.0°F
JPt (jpt 100 Ω)	-200.0 to 550.0°C	-328.0 to 1022.0°F

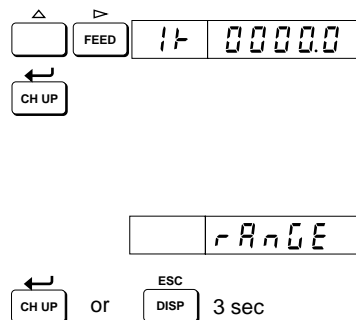

Select the desired minimum value (SPAN L) and maximum value of the recording span (SPAN R) in the same way as described under 'VOLT setting'.

The recording span cannot be beyond the input range, nor can SPAN L be equal to SPAN R.

[Range] is displayed and the setting is completed.

Press the **ENT** key to set another channel; or press the **DISP** key for three seconds to return to the Operation mode.

Scale Setting (SCL Setting)

To assign a different scale to the measured data, the range can be set as described below. Note that the measured data which can get a different scale must be of the voltage (VOLT).

Setting Procedures

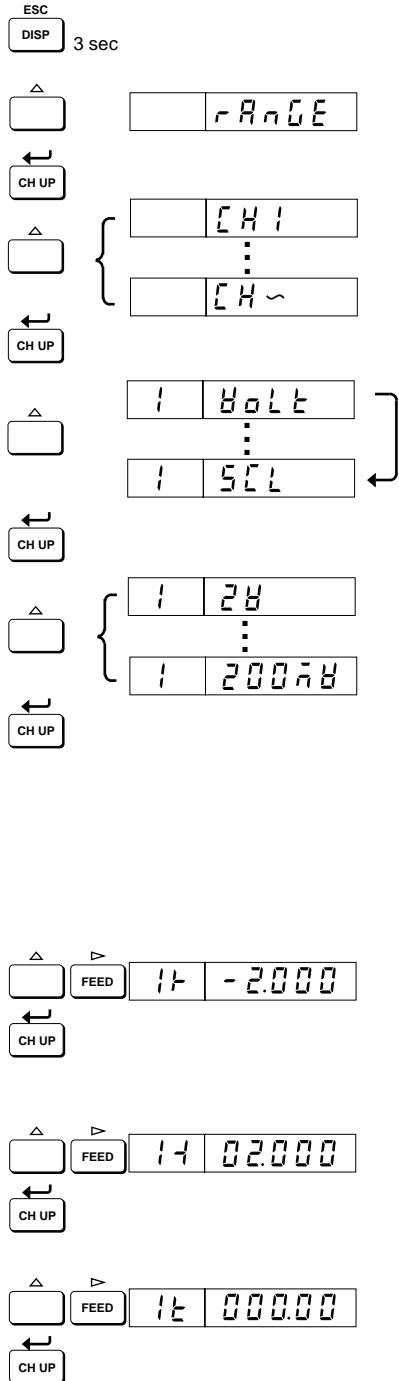

Press the **DISP** key for three seconds to enter the Regular Setting mode.

Select the **[Range]** display by using the \triangle key. Then press the **ENT** key.

Use the \triangle key to select the desired channel. Press the **ENT** key.

Use the \triangle key to select **[SCL]**. Press the **ENT** key.

Select the desired range using the \triangle key and press the **ENT** key.

VOLT Input Ranges

Display	Range
20mV	-20.00 to 20.00mV
60mV	-60.00 to 60.00mV
200mV	-200.0 to 200.0mV
2V	-2.000 to 2.000V
6V	-6.000 to 6.000V
20V	-20.00 to 20.00V

The display which appears will allow you to enter the minimum value of the recording span. Select the desired minimum value using the \triangle and \triangleright keys. Then press the **ENT** key.

The display which appears will allow you to enter the maximum value of the recording span. Select it the same way as the minimum value and press the **ENT** key.

The recording span cannot be beyond the input range, nor can SPAN L be equal to SPAN R.

This display allows you to enter the minimum value of the scale corresponding to the minimum value of the recording span. Select it using the \triangle and the \triangleright keys. The position of the decimal point can be moved using the \triangle key in case **[t]** is flashing. Note that the allowable range is -19999 to 20000. Then press the **ENT** key.

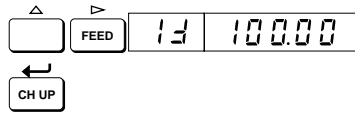

This display allows you to enter the desired maximum value of the scale corresponding to the maximum value of the recording span. Select it the same way as the minimum value. Then press the **ENT** key. Note that the decimal point will be in the same position as for SCL L. SCL L and SCL R cannot be same.

In this example, 0.000V input will be scaled to -100.0. 2.000V input will be scaled to 100.0.



[Range] is displayed and the setting is completed. Press the **ENT** key to set another channel; or press the **DISP** key for three seconds to return to the Operation mode.

2.3 Setting Alarm Functions

Alarms can be set on the measured data of any channel.

Up to two alarms (i.e. two levels) can be set on one channel.

After an alarm is set, and the measured value reaches the setpoint, the ALM LED will be illuminated.

Alarms can be used on models with the alarm output relay option (-A2, -A4) only.

[H]: High alarm Occurs when a measuring value is on or over the alarm setpoint.

[L]: Low alarm Occurs when a measuring value is under the alarm setpoint.

Setting Procedures

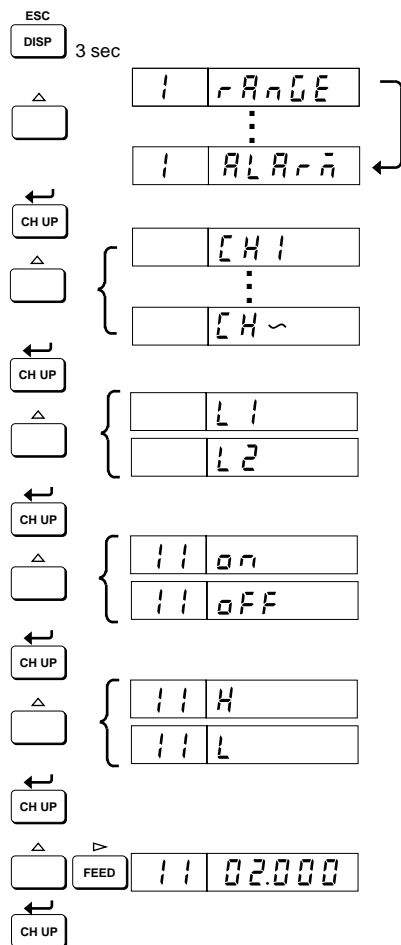

Press the **DISP** key for three seconds to enter the Regular Setting mode.

Select **[Alarm]** by pressing the **up arrow** key, and press the **ENT** key.

Select a channel by the **up arrow** key, and press the **ENT** key.

Select an alarm level by the **up arrow** key, and press the **ENT** key. Up to two levels can be set.

Select ON/OFF of the alarm settings by the **up arrow** key, and press the **ENT** key. Setting **[Off]** shows **[Alarm]** and ends this setting.

Select a type of alarms by the **up arrow** key, and press the **ENT** key.

The display which appears will allow you to enter the alarm value.

Set the alarm value using the **up arrow** and **right arrow** keys. After setting, press the **ENT** key.

The decimal point is predetermined by the input range.

Relationship between Input Range and Decimal Points

	Type of Input	Position of Decimal Point
DC Voltage	-20.00 to 20.00 mV	XXX. XX
	-60.00 to 60.00 mV	XXX. XX
	-200.0 to 200.0 mV	XXXX. X
	-2.000 to 2.000 V	XX. XXX
	-6.000 to 6.000 V	XX. XXX
	-20.00 to 20.00 V	XXX. XX
Thermocouple/RTD		XXXX. X

Relay Option Alarm Settings

The following settings are available only for the model with relay options (-A2, -A4). For models without these options, the alarm setting ends by pressing the **ENT** key until **[Alarm]** appears.

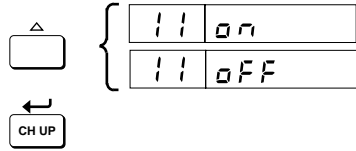

Determines whether the relay outputs a signal or not when an alarm occurs.

Select ON/OFF by the △ key, and press the **ENT** key.

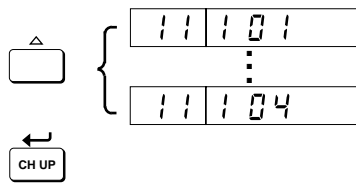

Sets the number of the relay after the alarm output ON is selected. A numeric to be set is selected from I01 to I04 by the △ key. Then press the **ENT** key.

If a number larger than the available number of output relays is selected, the alarm output will not implemented.

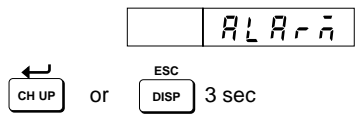

The setting ends with the **[Alarm]** indication.

When you want to set alarm settings for other channels continuously, press the **ENT** key to return to the channel setting.

In order to return to the operation mode, press the **DISP** key for three seconds.

Note

As a merged function, a combination of remote control option (-R) and alarm output relay option is available to change the chart speed when an alarm occurs.

2.4 Adjusting the Chart Speed

Relationships between chart speeds and their code numbers are shown below.

Chart Speed (unit: mm/h)

10	15	20	25	30	40	50	60	75	80
90	100	120	150	200	300	600	1200	1500	3000
6000									

The data for a dot model (10 mm/h to 1200 mm/h) are shown within the bold border.

Setting Procedures

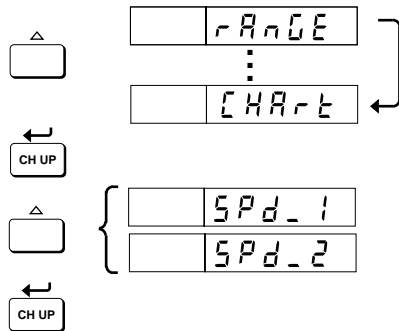

Press the **DISP** key for three seconds to enter the Regular Setting mode. Then press the **ENT** key.

Select **[Chart]** by pressing the \triangle key, and press the **ENT** key.

Using the \triangle key, select one of the two kinds of chart speed, the No.1 and No.2 chart speeds. Then press the **ENT** key. The No.2 chart speed identifies the chart speed which takes effect in case the speed is changed by remote control (optional function).

For models without the remote control function, the setting of the No.2 chart speed is invalid.

Select a numeric code referring to the table above using the \triangle key and press the **ENT** key.

The setting ends with the **[Chart]** indication.

When you want to continue to set another chart speed, press the **ENT** key. In order to return to the operation mode, press the **DISP** key for three seconds.

2.5 Setting the Dot Printing Interval (Dot Model)

This recorder prints in FIX or AUTO mode.

In FIX mode, dot printing is performed with a constant interval regardless of the chart speed (approx. 30 sec).

AUTO mode is provided to prevent the chart from being damaged during repetitive dot printing. This mode is useful for low chart speeds. The chart is protected from damage because the printout timing changes with the chart speed (approx. 30 to 90 sec).

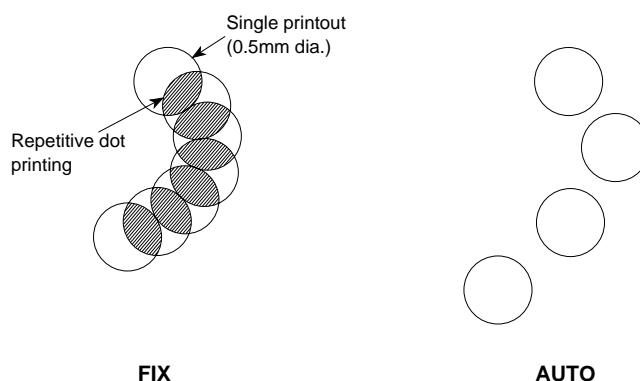

The initial value is 'AUTO'. To set the trend recording mode, proceed as follows:

Setting Procedures

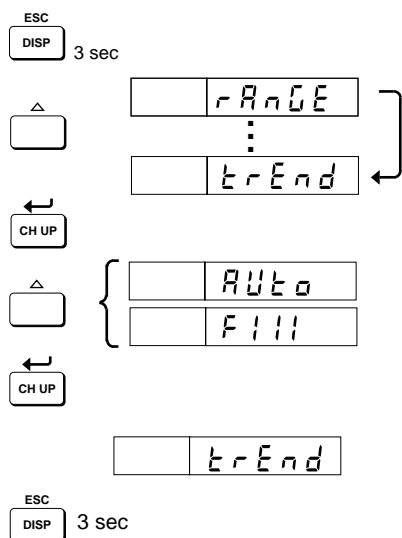

Press the **DISP** key for three seconds to enter the Regular Setting mode. Then press the **ENT** key.

Select the **[Trend]** display using the **△** key, and press the **ENT** key.

Specify **[Auto]** or **[Fix]** using the **△** key. Then press the **ENT** key.

[Trend] is displayed and the setting is completed. Press the **DISP** key for three seconds to return to the Operation mode.

2.6 Setting the Key-Lock

The key-lock can be set to be either ON or OFF for each key separately. Keys which can be locked are the **RCD**, and **FEED** keys.

Setting Procedures

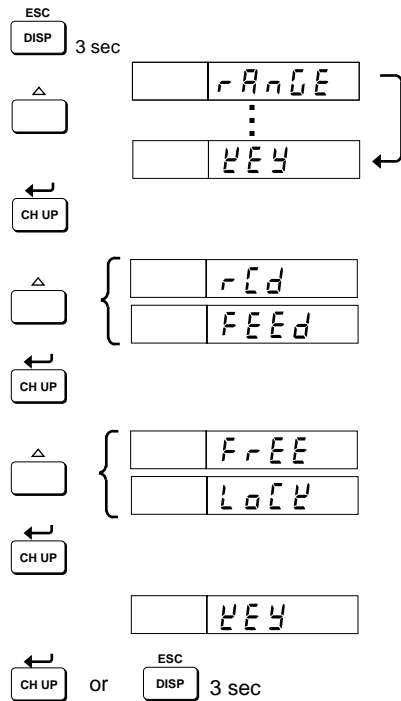

Press the **DISP** key for three seconds to enter the Regular Setting mode. Then press the **ENT** key.

Select the **[Key]** display using the Δ key, and press the **ENT** key.

Select a key to be locked using the Δ key and press the **ENT** key.

Select **[Lock]** to turn the key-lock on or select **[Free]** to turn it off, using the Δ key and press the **ENT** key.

[Key] is displayed and setting is completed. Press the **ENT** key to set another key; Press the **CH UP** (ESC) key or the **DISP** key for three seconds to return to the Operation mode.

3.1 Introduction to Basic (SETUP) Settings

Three Recorder Modes

Operation Mode

This is the mode for daily operation, described in the *User's Manual*; when the power turns on, the recorder automatically enters this mode.

Select from the following functions by pressing the appropriate keys on the key panel.

- △ key Replacement of pens (pen model only). See *User's Manual* Section 2.5.
- RCD key Starting/stopping the recording.
- FEED key Feeding the chart. See *User's Manual* Section 2.1.
- DISP key Selection from the modes on display. See *User's Manual* Section 1.1.

Regular Setting Mode, (see Section 2)

In the Regular Setting mode daily-used settings such as input range, recording span, alarm setpoints, and chart feed speed are made. Pressing the **DISP** key three seconds in the operation mode changes the mode to the Regular Setting mode.

Basic (SETUP) Setting Mode

In the Basic (SETUP) Setting Mode, described in this Chapter, you can adjust a whole range of detailed settings such as the pen's position, dot printing position and color, the noise input filter, a remote trigger settings. Enter this mode by turning the power on while pressing the **CH UP(ENT)** key.

Note

While in the Basic (SETUP) mode, measurement, recording, and alarm detection are not carried out.

Using the settings protection function, you can protect your settings by defining a password when you enter the Regular or Basic (SETUP) mode.

Turning the Recorder Modes ON

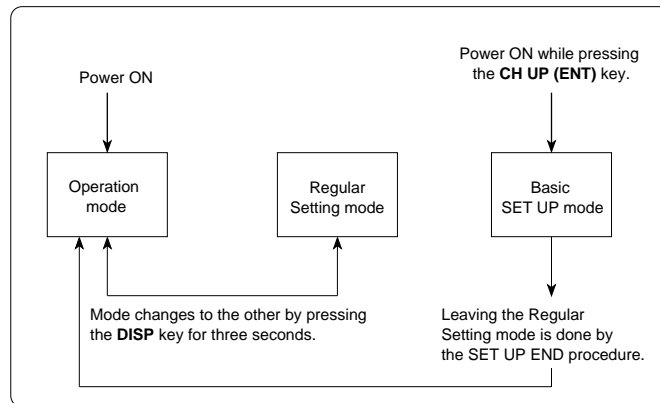

Turning the Recorder Modes OFF

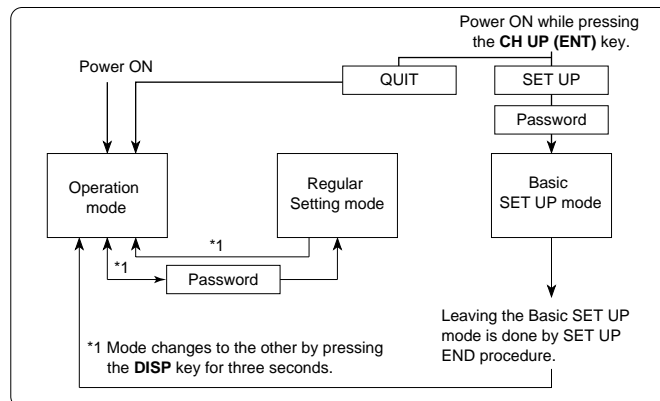

Flow Chart Basic (SETUP) Settings

3.2 Relay for post alarm (de-)energizing

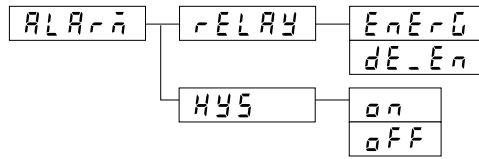

3.3 Alarm hysteresis

3.4 A/D integration time (pen model only)

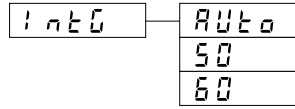

3.5 TC burnout registration method

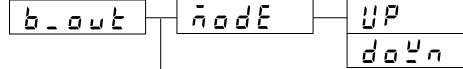

3.5 TC burnout on/off

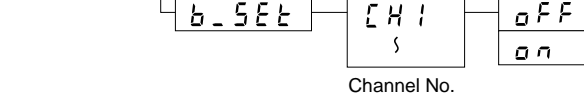

3.6 Noise input filter (pen model only)

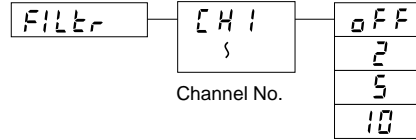

3.7 Moving average calculation (dot model only)

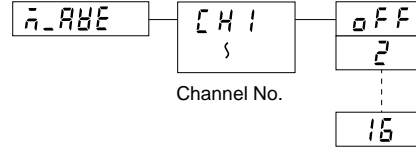

3.8 Offset settings protection

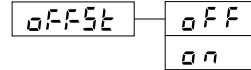

3.9 Channel printing colors (dot model only)

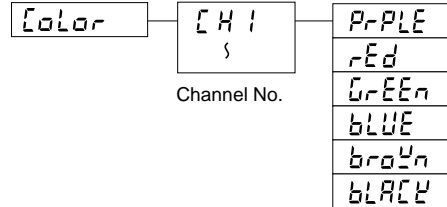

3.10 Selecting Celcius or Fahrenheit

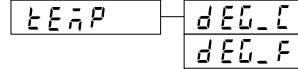

3.11 Remote trigger setting

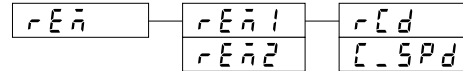

3.12 Protecting settings (key lock)

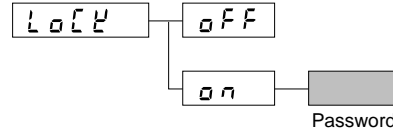

4.2/4.3 Pen/dot position adjustment

Pen-ZERO adjustment (pen model only)

Dot-ZERO adjustment (dot model only)

Pen-FULL adjustment (pen model only)

Dot-FULL adjustment (dot model only)

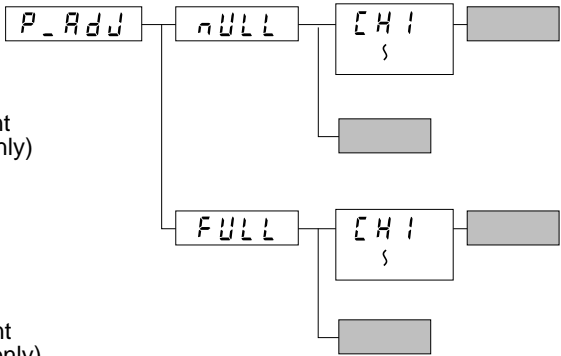

3.13 Initialization of settings

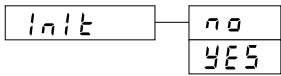

Explanations for these settings are not in this manual. Consult your purchasing source.

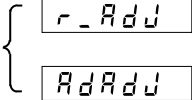

Termination of SETUP mode

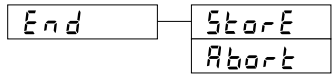

Grey box: Numeric value input







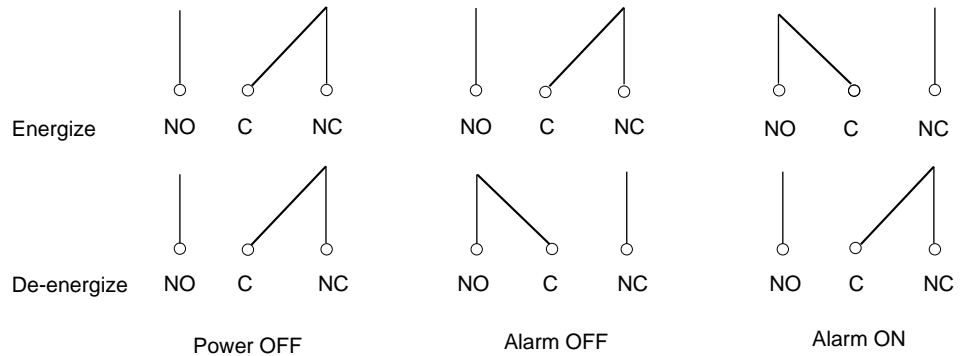

3.2 Setting Relay for post-Alarm (de-)Energizing

The alarm output relays can be selected to be energizing or de-energizing on alarm. Using de-energizing, alarm output relay is activated either when an alarm occurs, or when power off occurs (common for all relays). This enables simple monitoring of power supply.

The initial value is 'ENERG'.



Setting Procedure

	<p>Press power switch</p>	<p>Enter the Basic SET UP Mode by turning 'ON' the power while pressing and holding the CH UP (ENT) key until the SET UP display appears.</p>
	<div style="border: 1px solid black; padding: 2px; display: inline-block;">ALArñ</div>	<p>Use the Δ key to select the display [Alarm]. Press the ENT key.</p>
	<div style="border: 1px solid black; padding: 2px; display: inline-block;">rELAY</div>	<p>Press the Δ key until the display [Relay] appears. Press the ENT key.</p>
	<div style="display: flex; align-items: center;"> <div style="font-size: 2em; margin-right: 5px;">{</div> <div style="border: 1px solid black; padding: 2px; display: inline-block; margin-right: 5px;">EnERG</div> <div style="border: 1px solid black; padding: 2px; display: inline-block; margin-right: 5px;">dE_En</div> </div>	<p>Use the Δ key to select [Energ] or [De_En]. Press the ENT key. The display [Alarm] appears.</p>
	<div style="border: 1px solid black; padding: 2px; display: inline-block;">ALArñ</div>	<p>Before leaving the Basic SET UP Mode, you have to store your new settings. Use the Δ key to select the [End] display, and press the ENT key.</p>
	<div style="border: 1px solid black; padding: 2px; display: inline-block;">End</div>	
	<div style="border: 1px solid black; padding: 2px; display: inline-block;">StorE</div>	<p>Select [Store] to keep your new settings or [Abort] to abort the settings, and press the ENT key. After a few seconds, the Operation Mode will appear.</p>
	<div style="border: 1px solid black; padding: 2px; display: inline-block;">AborE</div>	

3.3 Setting Alarm Hysteresis

The alarm hysteresis is the difference between the levels of alarm occurrence and reset. You can choose between two levels of hysteresis: 0% (=OFF) and approx. 0.5% of the recording span (=ON) (common for all alarms). The initial value is ON.

High Limit Alarm (H)

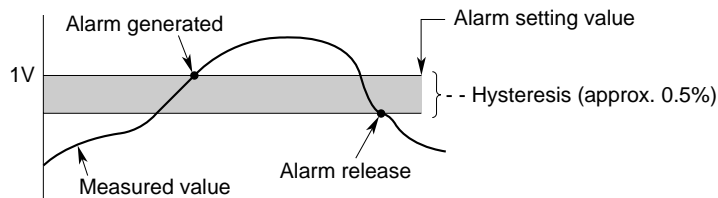

Low Limit Alarm (L)

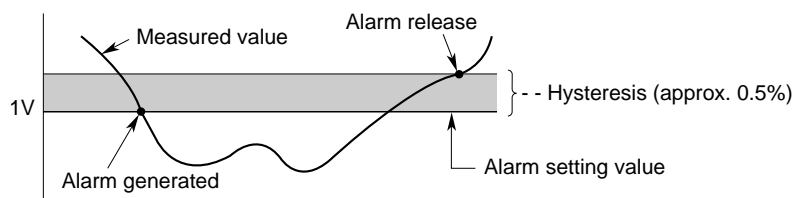

Setting Procedure



Press power switch

Enter the SET UP Mode by turning the power ON while pressing and holding the **CH UP** (ENT) key until the Basic SET UP display appears.



ALArñ

Use the Δ key to select the display **[Alarm]**. Press the **ENT** key.



rELAY

Press the Δ key until the display **[Hys]** appears. Press the **ENT** key.



HYS



on
off

Use the Δ key to select the **[On]**, or **[Off]**. Press the **ENT** key. The display **[Alarm]** appears.



ALArñ

Before leaving the Basic SET UP Mode, you have to store your new settings. Use the Δ key to select the **[End]** display, and press the **ENT** key.



End



StorE
AborE

Select **[Store]** to keep your new settings or **[Abort]** to abort the settings, and press the **ENT** key. After a few seconds, the Operation Mode will appear.



3.4 Selecting A/D Integration Time (Pen Model)

Setting 50-60Hz A/D Integration Time

The purpose of the following setting is to specify which A/D integration time will be used. Depending on the power supply, the integration time will affect the ability of noise rejection and therefore the recording.

If the power supply of the recorder and of the measuring object are the same, the effect of noise will be automatically minimized and the (initial) value of AUTO is the recommended one.

If the power supplies are different, you should select from 50Hz or 60Hz integration time. The choice depends on the power supply of the instrument with the highest noise level.

There are three possibilities:

- AUTO: integration time depends on the power supply of the recorder. AUTO is the initial value.
- 50 Hz.
- 60 Hz.

Setting Procedure

Press power switch

Enter the SET UP Mode by turning ON the power while pressing and holding the **CH UP** (ENT) key until the Basic SETUP display appears.

Use the Δ key to select the display **[Intg]**. Press the **ENT** key.

Select AUTO, 50Hz or 60Hz according to your situation using the Δ key. Then press the **ENT** key. The display **[Intg]** appears.

Before leaving the Basic SET UP Mode, you have to store your new settings. Use the Δ key to select the **[End]** display, and press the **ENT** key.

Select **[Store]** to keep your new settings or **[Abort]** to abort the settings, and press the **ENT** key. After a few seconds, the Operation Mode will appear.

The diagram illustrates the following steps:

- Press the **CH UP** key to enter the Basic SETUP mode. The display shows **ALARM**.
- Press the Δ key to scroll down to **Intg**. Press the **ENT** key.
- Press the Δ key to scroll down to **AUTO**, **50**, or **60**. Press the **ENT** key.
- Press the Δ key to scroll down to **Intg**. Press the **ENT** key.
- Press the Δ key to scroll down to **End**. Press the **ENT** key.
- Press the Δ key to scroll down to **Store** or **Abort**. Press the **ENT** key.

3.5 TC Burnout Registration Method

The purpose of the following setting is to specify where the pens will move in the case of a TC-burnout. You can choose from moving to the right (UP) or to the left (DOWN). This is common for every channel. You can select ON or OFF for each channel. The initial value is [UP], and [OFF] for every channel.

Setting Procedure

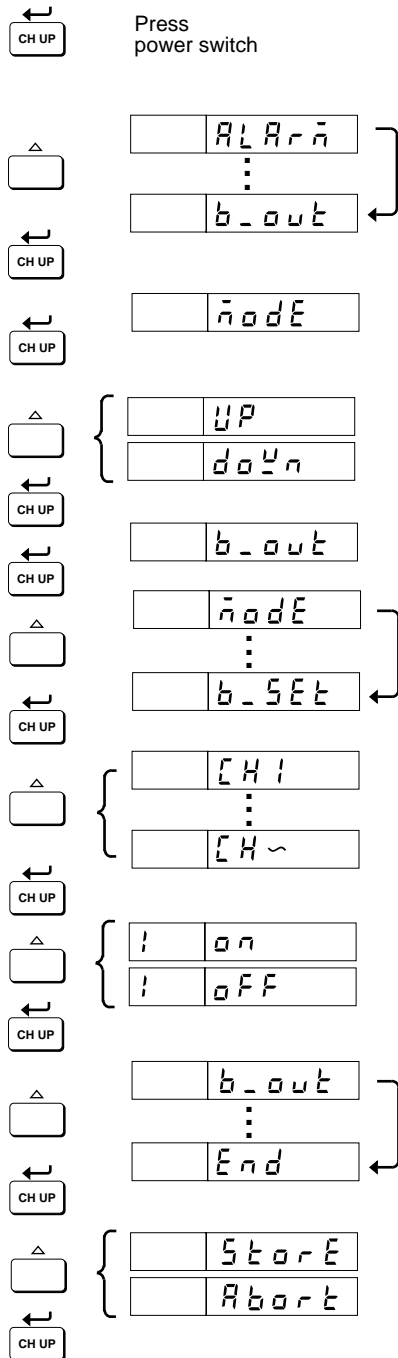

Enter the Basic SET UP Mode by turning the power **ON** while pressing and holding the **CH UP** (ENT) key until the SET UP display appears.

Use the \triangle key to select the display [**B_Out**]. Press the **CH UP** (ENT) key.

Use the \triangle key to select the display [**Mode**]. Press the **CH UP** (ENT) key.

Select [**UP**] or [**DOWN**] using the \triangle key. Press the **ENT** key.

The display [**B_Out**] appears. Press the **ENT** key. Note that this burnout processing is ON/OFF selectable per channel.

Use the \triangle key to select the display [**B_Set**]. Press the [**ENT**] key.

Select the channel No. using the \triangle key for which you want to specify this burnout processing. Then press the **ENT** key.

Select [**ON**] or [**OFF**]. Then press the **ENT** key. The display [**B_Out**] appears.

Before leaving the Basic SET UP Mode, you have to store your new settings. Use the \triangle key to select the [**End**] display, and press the **ENT** key.

Select [**Store**] to keep your new settings or [**Abort**] to abort the settings, and press the **ENT** key. After a few seconds, the Operation Mode will appear.

3.6 Setting the Noise Input Filter (Pen Model)

Configuring the Input Filter

Noise in the measured signal can be suppressed in the final measurement by using an input filter. The purpose of this setting is to select for each channel whether or not to use a filter, and if so, to select a time constant of damping.

A filter works as follows:

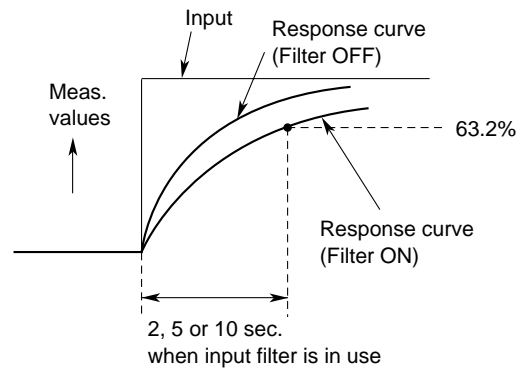

If a filter is used, the response time can be selected from 2, 5 or 10 seconds. The initial value is 'OFF'.

Setting Procedure

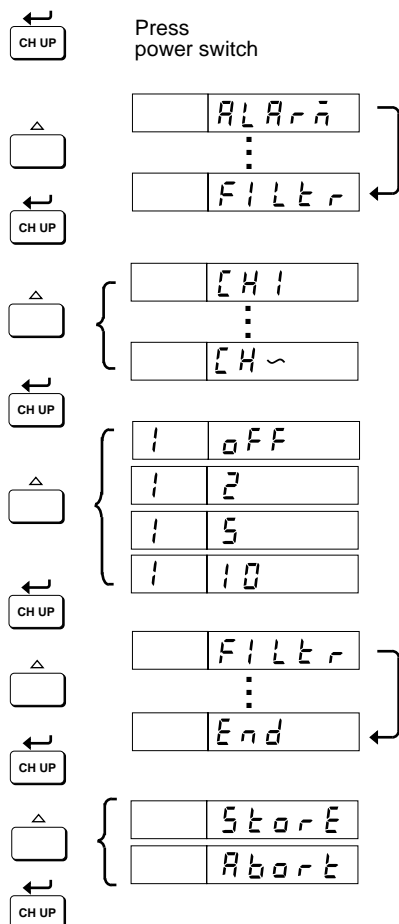

Enter the Basic SET UP Mode by turning ON the power while pressing and holding the **CH UP** (ENT) key until the SET UP display appears.

Use the Δ key to select the display **[Filtr]**. Press the **ENT** key.

Select the channel No. using the Δ key for which you want to specify a filter. Then press the **ENT** key.

Use the Δ key to select the type of filter you want to use. You can choose from no filter (OFF), 2 seconds, 5 seconds or 10 seconds. Press the **ENT** key. The display **[Filtr]** will appear.

Press the **ENT** key to continue the setting for other channels.

The filter setting has been completed, but has not been stored yet. Before leaving the Basic SET UP Mode, you have to store your new settings. Use the Δ key to select the **[End]** display, and press the **ENT** key.

Select **[Store]** to keep your new settings or **[Abort]** to abort the settings, and press the **ENT** key. After a few seconds, the Operation Mode will appear.

3.7 Setting Moving Average Calculation (Dot Model)

Noise in the measured signal can be suppressed in the final measurement by computing a moving average. It is possible to record a moving average calculated over the previous X samples, selectable from the previous 2 to 16 samples. The purpose of the following setting is to select for each channel whether or not to compute a moving average, and if so, over how many samples.

One sampling period is 10 seconds. The initial value is 'OFF.'

Example: (assuming a moving average over 5 samples is selected)

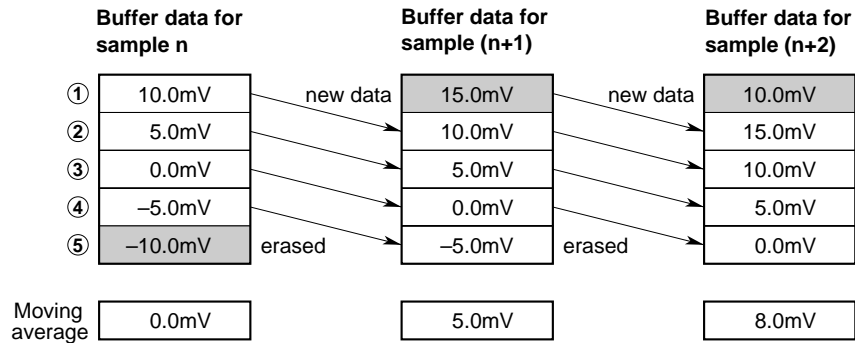

Setting Procedure

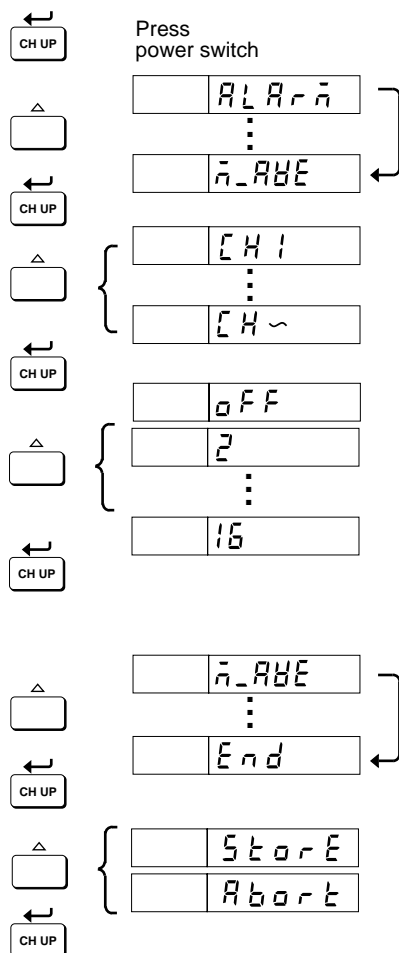

Enter the Basic SET UP Mode by turning ON the power while pressing and holding the **CH UP** (ENT) key until the SET UP display appears.

Use the Δ key to select the display **[M_Ave]**. Press the **ENT** key.

Select the channel No. using the Δ key for which you want to compute a moving average. Then press the **ENT** key.

Use the Δ key to select the number of samples. You can choose from OFF, 2 samples, 3 samples, ... up to 16 samples. Of course you can also select OFF. Press the **ENT** key. The display **[M_Ave]** will appear.

Press the [ENT] key to continue the setting for other channels.

The moving average setting has been completed, but has not been stored yet. Before leaving the Basic SET UP Mode, you have to store your new settings. Use the Δ key to select the **[End]** display and press the **ENT** key.

Select **[Store]** to keep your new settings or **[Abort]** to abort the settings, and press the **ENT** key. After a few seconds, the Operation Mode will appear.

3.8 Offset Values

Offset Value Security Lock

Configure the recorder so changes can (**ON**) or cannot (**OFF**) be made to the Offset settings in the Regular Setting mode.

When protection is turned on, you can set an offset value in the SET mode.
The initial value is **[OFF]**.

Setting Procedure

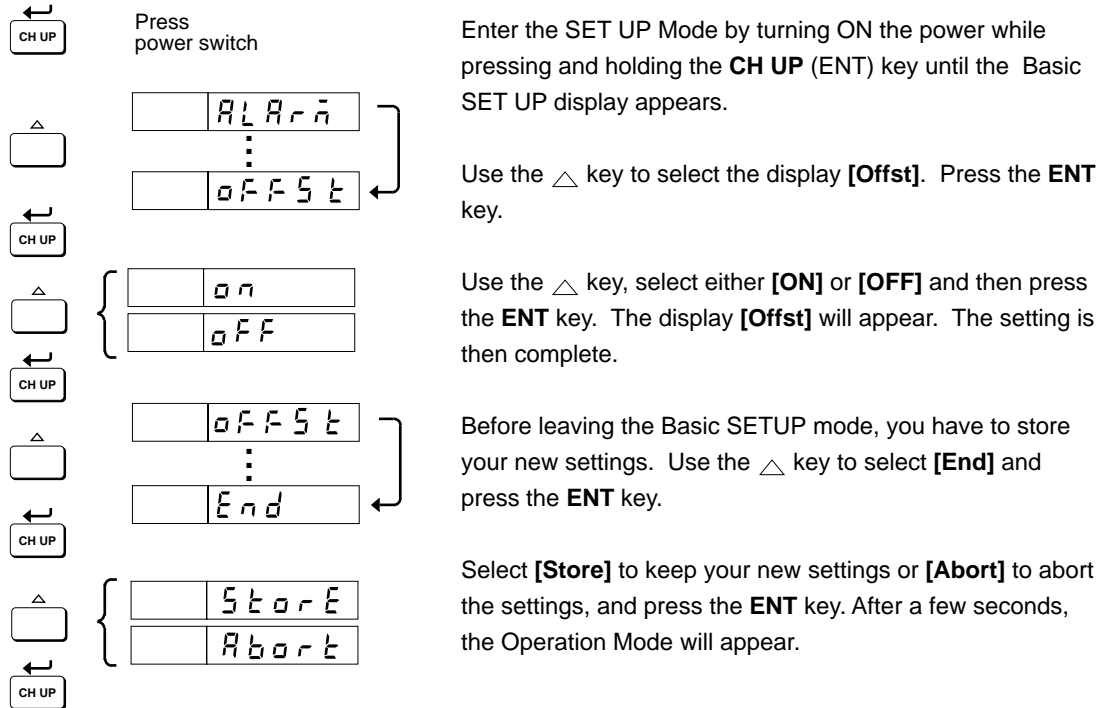

Setting Offsets (Regular Setting)

When recording and showing data using the current input as the reference, measured values can be corrected within 10% of the span. For example, assume the reading is 1.998 V for the current level of input. If you want to change the reading to 2.000 V, set 0.002 V as the offset. This menu opens only when offset settings protection is turned on in the SETUP mode.

Setting Procedures

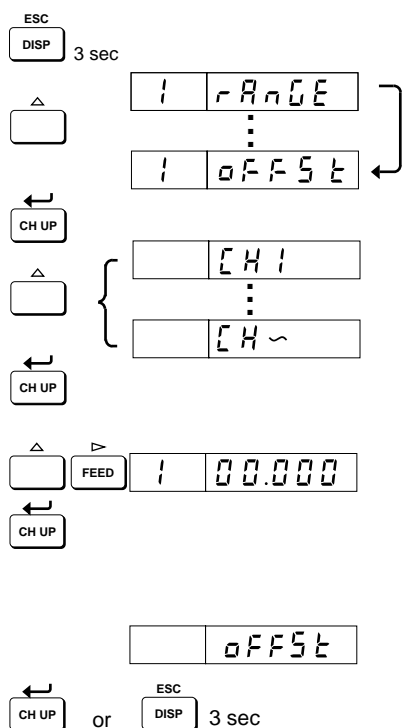

Press the **DISP** key for three seconds to enter the SET mode. Using the Δ key, select **[Offset]** and then press the **CH UP** (ENT) key.

Using the Δ key, select the channel to be configured and then press the **ENT** key. Configurable channels are those whose measuring range is VOLT, TC, RTD or SCL.

Type the value of offset. Use the \triangleright key to move through the digits and the Δ key to select a numeral. When setting is complete, press the **ENT** key. Set the offset within 10% of the recording span.

[Offst] appears and the setting is then complete. To continue, press the **ENT** key and start again with channel selection. Pressing the **ESC** key while making settings returns to the screen showing **[Offst]**. To return to the OPERATION mode, hold down the **DISP** key for 3 seconds.

3.9 Assigning Channel Printing Colors (Dot Model)

You can assign any of the six provided colors to any channel. The initial setting is as follows:

- ch.1 = purple
- ch.2 = red
- ch.3 = green
- ch.4 = blue
- ch.5 = brown
- ch.6 = black

Setting Procedure

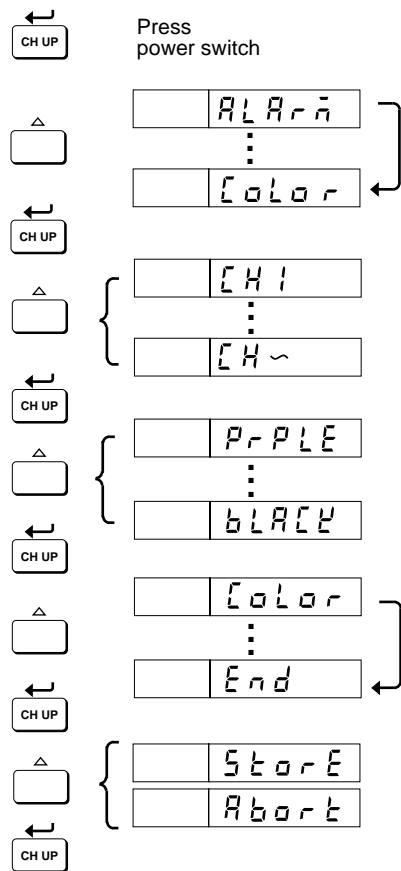

Enter the SET UP Mode by turning ON the power while pressing and holding the **CH UP** (ENT) key until the Basic SET UP display appears.

Use the Δ key to select the display **[Color]**. Press the **ENT** key.

Select the channel No. for which you want to change a color. Then press the **ENT** key.

Select the color. Then press the **ENT** key. The display **[Color]** will appear.

Before leaving the Basic SET UP Mode, you have to store your new settings. Use the Δ key to select the **[End]** display and press the **ENT** key.

Select **[Store]** to keep your new settings or **[Abort]** to abort the settings, and press the **ENT** key. After a few seconds, the Operation Mode will appear.

3.10 Selecting Celsius or Fahrenheit

You can set the standard unit of temperature to either Celsius or Fahrenheit.
The default setting for recorders is Celsius.

Setting Procedure

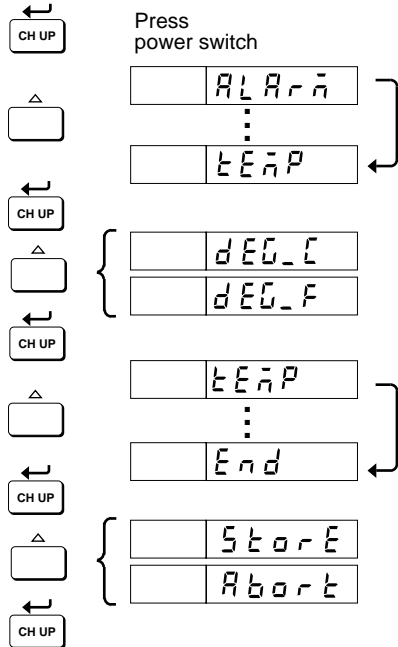

Enter the SET UP Mode by turning ON the power while pressing and holding the **CH UP** (ENT) key until the Basic SET UP display appears.

Use the \triangle key to select the display **[Rem]**. Press the **ENT** key.

Choose the standard unit of temperature from **[Deg_C]** (degrees Celsius), or **[Deg_F]** (degrees Fahrenheit). Press the **ENT** key. The display **[Temp]** appears.

Before leaving the Basic SET UP Mode, you have to store your new settings. Use the \triangle key to select the **[End]** display, and press the **ENT** key.

Select **[Store]** to keep your new settings or **[Abort]** to abort the settings, and press the **ENT** key. After a few seconds, the Operation Mode will appear.

3.11 Remote Trigger for Recording or Chart Speed

This paragraph describes the way to change default settings for REMOTE operation. The settings concerning the REMOTE option are always accessible, and data entry will be ignored if your instrument is not equipped with this option.

The -R option allows you to execute functions on this instrument by a remote trigger (contact input).

The functions which can be executed by a remote trigger are:

- start/stop the recording
- change the chart speed to a preset second chart speed

However, the -R terminal has only two terminals, which means that only two functions can be triggered.

Initially the functions are assigned to the terminals as follows:

- 1: start/stop the recording **[RCD]** (Record)
- 2: change the chart speed to a preset second chart speed **[C_Spd]** (Chart Speed)

Setting Procedure

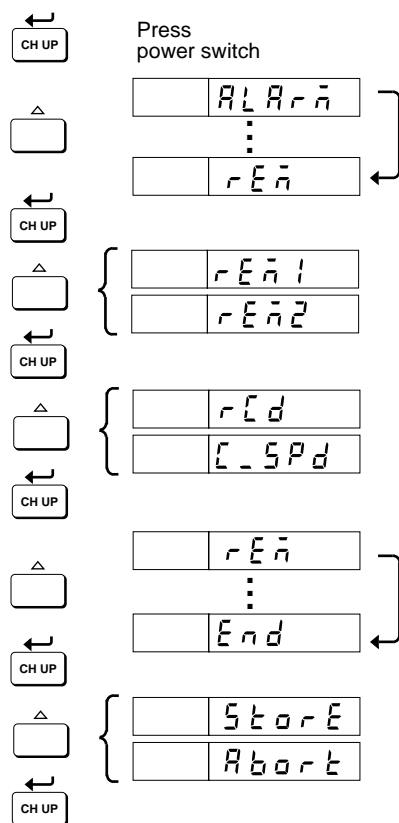

Enter the SET UP Mode by turning ON the power while pressing and holding the **CH UP** (ENT) key until the Basic SET UP display appears.

Use the Δ key to select the display **[Rem]**. Press the **ENT** key.

Select the terminal No. **[Rem1]** or **[Rem2]** (/R1 has two terminals.) Press the **ENT** key.

Select the function which you want to assign to that terminal. You can choose from **[RCD]** (start/stop recording), or **[C_Spd]** (second chart speed). Press the **ENT** key. The display **[Rem]** appears.

Before leaving the Basic SET UP Mode, you have to store your new settings. Use the Δ key to select the **[End]** display, and press the **ENT** key.

Select **[Store]** to keep your new settings or **[Abort]** to abort the settings, and press the **ENT** key. After a few seconds, the Operation Mode will appear.

Note

If you select 'start/stop recording,' recording stops if the remote input terminal is open and starts if the terminal is closed. If you press the **RCD** key during the startup of remote-controlled recording, recording stops. In contrast, if you press the **RCD** key during the shutdown of remote-controlled recording, recording starts. You can start/stop remote-controlled recording even during the start/stop sequence of recording based on the **RCD** key.

3.12 Protecting Settings

You can protect your settings made in the Regular Setting or Basic SETUP modes using a password.

- If you select **[OFF]**:
the choice does not affect operation in any mode.
- If you select **[ON]**:

You must type in a password to enter the Regular Setting or Basic SETUP modes. The password discussed here is one you set in the following procedure.

The initial value is **[OFF]**.

Setting Procedure

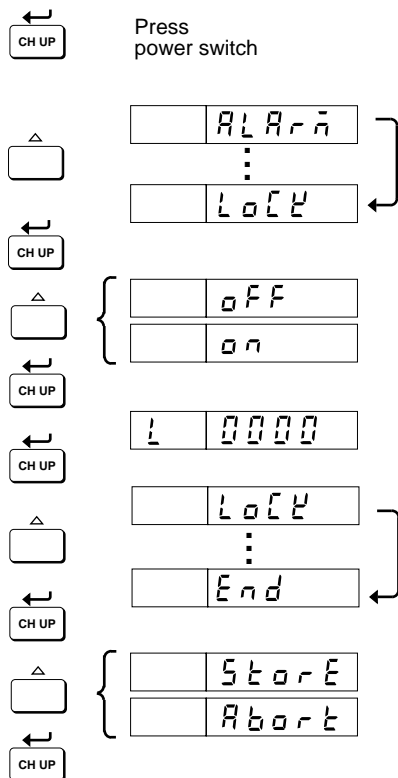

Enter the SET UP Mode by turning 'ON' the power while pressing and holding the **CH UP** (ENT) key until the Basic SET UP display appears.

Use the Δ key to select the display **[Lock]**. Press the **ENT** key.

Select **[ON]** or **[OFF]**. Press the **ENT** key. In the case you selected Off, the setting is completed.

Select a password composed of four digits. After setting is finished, press the **ENT** key. The display **[Lock]** appears.

Before leaving the SET UP Mode, you have to store your new settings. Use the Δ key to select the **[End]** display and press the **ENT** key.

Select **[Store]** to keep your new settings or **[Abort]** to abort the settings, and press the **ENT** key. After a few seconds, the Operation Mode will appear.

3.13 Initializing Settings

The settings which can be initialized concern the settings done in the Regular setting Mode only. This initialization does not affect any settings in the Basic SET UP Mode.

Setting Procedure

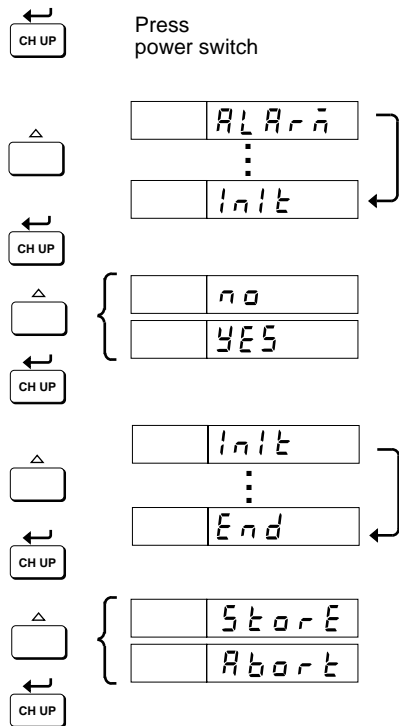

Enter the Basic SET UP Mode by turning ON the power while pressing and holding the **CH UP** (ENT) key until the SET UP display appears.

Use the \triangle key to select the display **[Init]**. Press the **ENT** key.

Select **[Yes]** or **[No]** using the \triangle key.

Press the **ENT** key. The display **[Init]** appears.

When leaving the Basic SET UP Mode, and you want to initialize your settings, select the **[End]** display with the \triangle key and press the **[ENT]** key.

Select **[Store]** to keep your new settings or **[Abort]** to abort the settings, and press the **ENT** key. After a few seconds, the Operation Mode will appear.

4.1 Calibration

Calibration is a comparing operation between standard inputs and measured values. It is recommended to carry out a calibration once a year to assure the measuring accuracy.

Required Instruments

The instruments for calibration should have the required resolution. If necessary, ask the sales office from whom you purchased the recorder about those instruments.

- Required instruments:
- DC voltage standard
 - Decade resistance box

Calibration Connections

1. Connect the instruments to the recorder; connecting the terminals is shown below. Give enough warm-up time to the instruments (more than 30 minutes for the recorder).

Temperature Measurement for Resistance Temperature Detector (RTD)

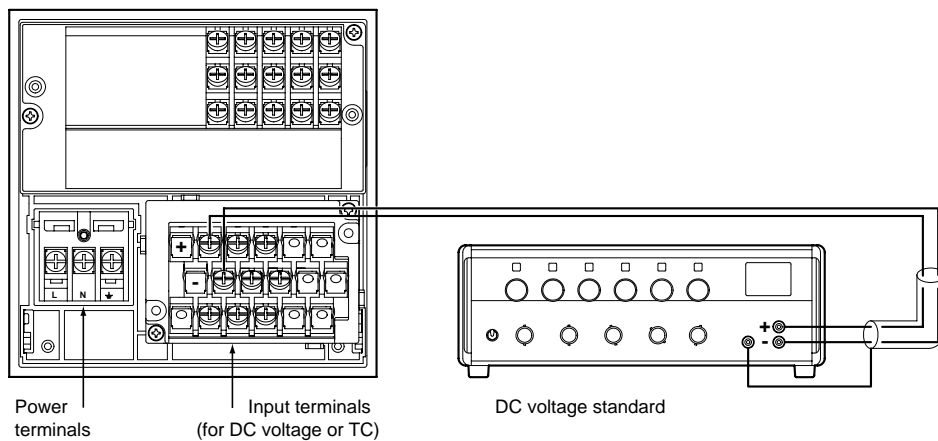

Temperature Signal as RTD for Dot-printing Model

(for dot-printing model, the wire connection exchanges between the terminal B and b.)

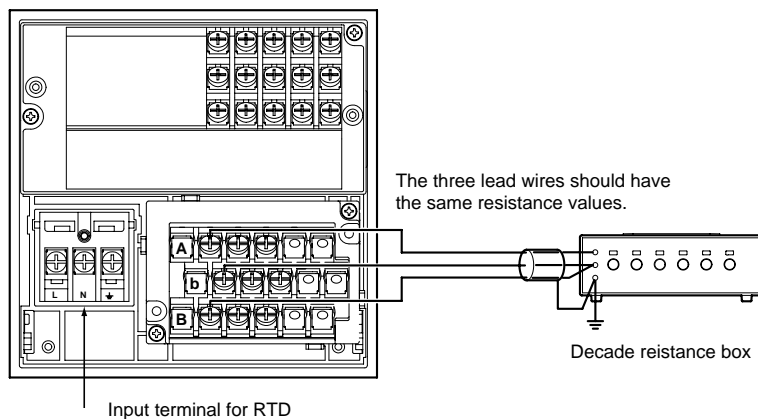

Temperature Compensation for Thermocouple Signal

Reference Temperature Compensating Connection for Pen Model (same as Dot-Printing Model)

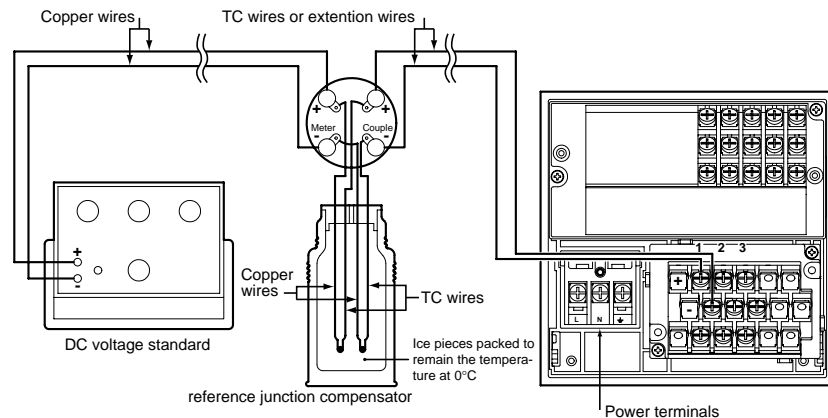

Reference Junction Compensation for Thermocouple Input

A DC voltage generated by a thermocouple differs from a value calculated from the table of thermo-electromotive force (EMF) because the table is based on the 0°C reference temperature but the temperature at the recorder input terminal is generally equal to the room temperature.

The recorder measures the temperature at the input terminal for compensation; when the input terminals are shorted (equivalent to 0°C of the thermocouple in the EMF table), the recorder indicates the temperature at the input terminal.

For calibrating a recorder, an input voltage after the compensation (after subtraction of the compensating voltage) should be applied to the recorder.

Operating Conditions

2. Check that the ambient temperature and humidity are within the standard operating conditions.

Standard operating conditions

Ambient temp.: 23±2°C

Humidity: 55±10% RH

Power supply: 90 to 132 V AC, or 180 to 250 V AC

Power frequency: 50/60 Hz±0.1%

Warm-up time: 30 minutes or more

Mechanical vibration: Within the range not affecting recorder operation

However, when the calibration is conducted under normal operating conditions, check the accuracy influenced by the conditions.

Chart paper yields thermal expansion or shrinkage, sometimes resulting in differences from the calibrated values.

Examples of expansion are shown below assuming the reference temperature 20°C and humidity 65% RH:

Expansion at 85% RH: 0.4% or less

Expansion at 35% RH: 0.45% or less

Executing Calibration

3. Input the standard signals equivalent to 0, 50, and 100% of the setting range of the recorder, then check the difference error between input signals and measured values. If the error is not within the specified accuracy, contact the dealer from which you purchased the recorder.

A reference input for a thermocouple (TC) signal needs temperature compensation; the temperature at the recorder input terminal should be measured to make voltage compensation (adding) due to the reference junction temperature compensation.

4.2 Re-adjusting the Pen-Position (Pen Model)

It is recommended to adjust pen positions on the chart at least once a year.

Preparation

1 Turn the recorder power on and allow a warm-up time of more than 30 minutes.

2 Check that the environmental conditions are within normal operating conditions.

Normal operating conditions

Power supply: 90 to 132 V AC, or 180 to 250 V AC

Power frequency: 50/60 Hz \pm 2%

Ambient temp.: 0 to 50°C

Ambient humidity: 20 to 80% RH (under 5 to 40°C)

Mechanical vibration: 10 to 60 Hz, 0.2 m/s² or less

Mechanical shock: Not permitted

Magnetic field: 400 AT/m or less (DC and 50/60 Hz)

External noise: Normal mode (50/60 Hz)

DC voltage: Noise peak value with signal is limited to 1.2 times larger value than the measuring range.

TC signal: Noise peak value with signal is limited to 1.2 times larger value than the measuring thermoelectromotive force.

RTD signal: 50 mV or less

Common mode noise (50/60 Hz): 250 V AC rms or less for any range.

Maximum noise voltage between channels (50/60 Hz): 250 V AC rms or less.

Mounting inclination : Backward 0 to 30°

Chart paper yields thermal expansion or shrinkage, sometimes resulting in differences from the calibrated values. Adjust the pen position, if necessary.

Examples of expansion are shown below assuming the reference temperature 20°C and humidity 65% RH:

Expansion at 85% RH: 0.4% or less

Expansion at 35% RH: 0.45% or less

Setting Procedure

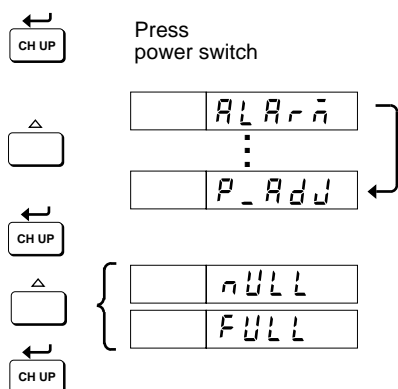

To enter the Basic SET UP mode, turn the power switch off, and turn on again while pressing the **CH UP** (ENT) key.

Select [**P_Adj**] using the Δ key, and press the **ENT** key.

Select [**Null**] (leftward movement) or [**Full**] (rightward movement) using the Δ key, and press the **ENT** key. Adjust the pen positions in the order of NULL to FULL (continued on next page).

Re-adjusting the Pen-Position (Pen Model)

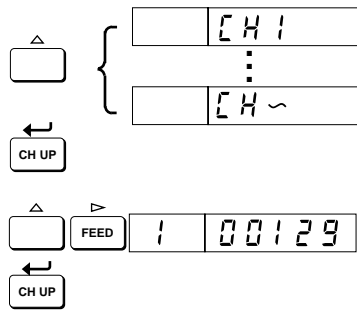

Select the number of the channel to be adjusted using the Δ key, and press the **ENT** key.

The selected pen moves leftward (for NULL) or rightward (for FULL). Increase or decrease the setpoint value to make the pen accurately overlap the graduated line of the chart. Select the digit by pressing the \triangleright key, and select a numeral by the Δ key. Setting range is 126 to 229 for NULL, 900 to 1100 for FULL. Finally press the **ENT** key after all codes are entered.

The pen will move after pressing the **ENT** key. The pen movement corresponding to **[1]** is 0.1 mm. Decreasing the numeral moves the pen leftward, and increasing moves the pen rightward.

If the **ENT** key is pressed while setting the numeric codes, the indication changes to **[-Set-]**, and the numeric codes already set remain valid. However, they will become invalid if the **ESC** key is pressed.

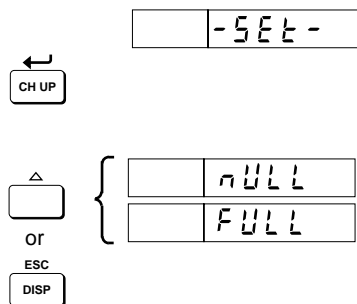

The indicator displays **[-Set-]**, and the pen will move to the adjusted position.

Confirm the pen position and press the **ENT** key.

The indicator returns to **[Null]** or **[Full]**. When you want to carry out the position adjustment again, press the **ENT** key and start) again. When another adjustments are required, select **[Null]** or **[Full]** again by pressing the Δ key. In order to finish the adjustment, press the **ESC** key to return to the **[P_Adj]** indication.

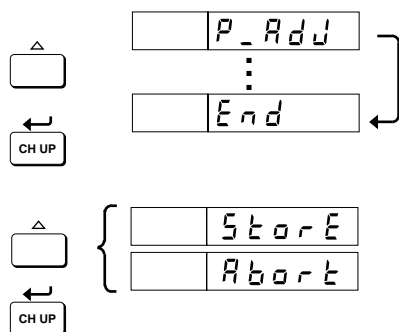

Before leaving the SET UP mode, its contents should be stored.

Select **[End]** by pressing the Δ key, and press the **ENT** key.

Select **[Store]** to keep setting values valid, or select **[Abort]** to abort them by pressing the Δ key, and press the **ENT** key.

The Basic SET UP mode finishes, and several seconds after, the mode returns to the Operation mode.

4.3 Re-adjusting the Dot-Position (Dot Model)

It is recommended to adjust the position of dots at least once a year.

Preparation

- 1 Turn the recorder power on and allow a warm-up time of more than 30 minutes.
- 2 Check that the environmental conditions are within normal operating conditions.

Normal operating conditions

Power supply: 90 to 132 V AC, or 180 to 250 V AC

Power frequency: 50/60 Hz \pm 2%

Ambient temp.: 0 to 50°C

Ambient humidity: 20 to 80% RH (under 5 to 40°C)

Mechanical vibration: 10 to 60 Hz, 0.2 m/s² or less

Mechanical shock: Not permitted

Magnetic field: 400 AT/m or less (DC and 50/60 Hz)

External noise: Normal mode (50/60 Hz)

DC voltage: Noise peak value with signal is limited to 1.2 times larger value than the measuring range.

TC signal: Noise peak value with signal is limited to 1.2 times larger value than the measuring thermoelectromotive force.

RTD signal: 50 mV or less

Common mode noise (50/60 Hz): 250 V AC rms or less for any range.

Maximum noise voltage between channels (50/60 Hz): 250 V AC rms or less.

Mounting inclination : Backward 0 to 30°

Chart paper yields thermal expansion or shrinkage, sometimes resulting in differences from the calibrated values. Adjust the pen position, if necessary.

Examples of expansion are shown below assuming the reference temperature 20°C and humidity 65% RH:

Expansion at 85% RH: 0.4% or less

Expansion at 35% RH: 0.45% or less

Setting Procedure

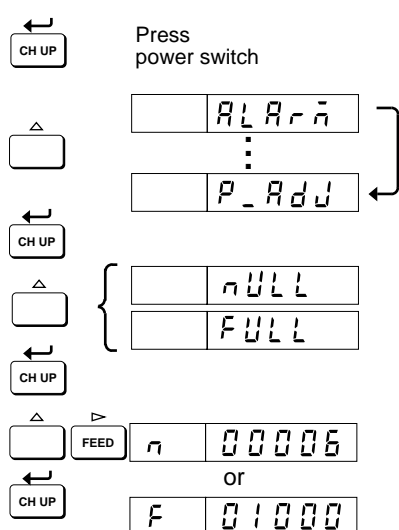

To enter the SET UP mode, turn the power switch off, and turn on again while pressing the **ENT** key.

Select [**P_Adj**] by pressing the Δ key, and press the **ENT** key.

Select [**Null**] (leftward movement) or [**Full**] (rightward movement) by pressing the Δ key, and press the **ENT** key.

Increase or decrease the setpoint value to make the dot position accurately overlap the graduated line of the chart. The setting range is 1 to 15 for [**Null**], and 980 to 1017 for [**Full**]. Finally press the **ENT** key after all codes are entered.

The dot position movement corresponding to **[1]** is 0.1 mm. Decreasing the numeral moves the dot position leftward, and increasing moves it rightward.

If the **ENT** key is pressed while setting the numeric codes, the indication changes to **[-Set-]**, and the numeric codes already set stay valid. However, pressing the **ESC** key turns them invalid.

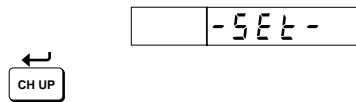

The indicator displays **[-Set-]**, and the dot carriage will move to the adjusted position.

Confirm the dot carriage position and press the **ENT** key.

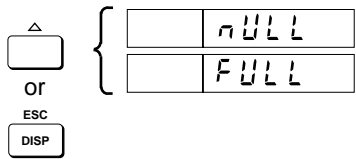

The indication returns to **[Null]** or **[Full]**. When you want to carry out the position adjustment again, press the **ENT** key and start again.

In order to finish the adjustment, press the **ESC** key to return to the **[P_Adj]** indication.

When other adjustments are required, select **[Null]** or **[Full]** again by pressing the Δ key.

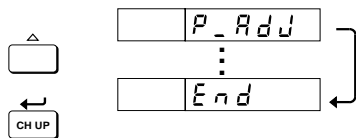

Before leaving the SET UP mode, its contents should be stored.

Select **[End]** by pressing the Δ key, and press the **ENT** key.

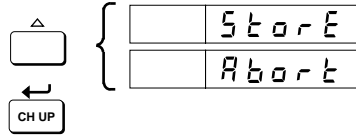

Select **[Store]** to keep setting values valid, or select **[Abort]** to abort them by pressing the Δ key, and press the **ENT** key.

The Basic SET UP mode finishes, and several seconds after, the mode returns to the Operation mode.

5.1 Periodic Inspection

Check the following items periodically, and replace parts, if necessary:

Character printing

Are recorded lines or printed characters clear, not blurred?

To replace a felt-tip pen, refer to the *User's Manual* Section 2.5 *Installing/Replacing Pens*; also, refer to *User's Manual* Section 2.6 *Installing/Replacing Ribbon Cassette* to replace the ribbon cassette of a dot-printing model.

Chart paper

Is there enough chart paper left in the chart compartment ?

Remaining chart length (cm) is printed on the left margin of the chart at intervals of 20 cm. See also *User's Manual* Section 2.4 *Loading Chart Paper*.

Indication of Remaining Chart Length:

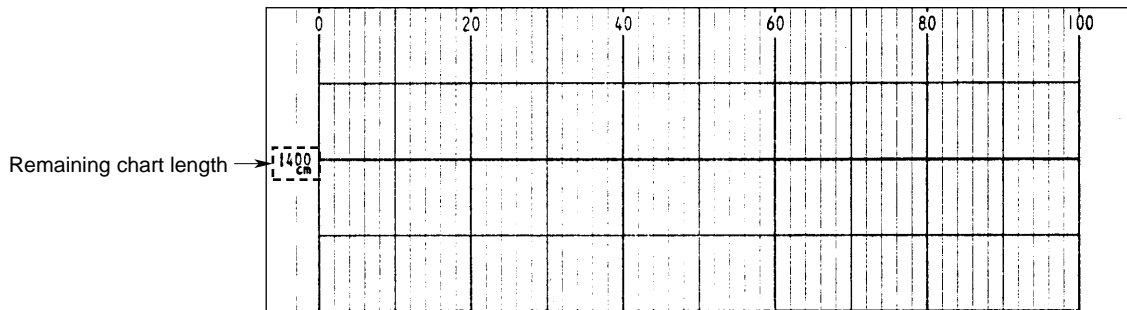

Cleaning the Carriage Shafts (Dot Model)

To maintain proper recording functions, it is recommended to, if necessary, wipe up dust from the shaft of the printer carriage with a piece of soft cloth or paper without fluffing.

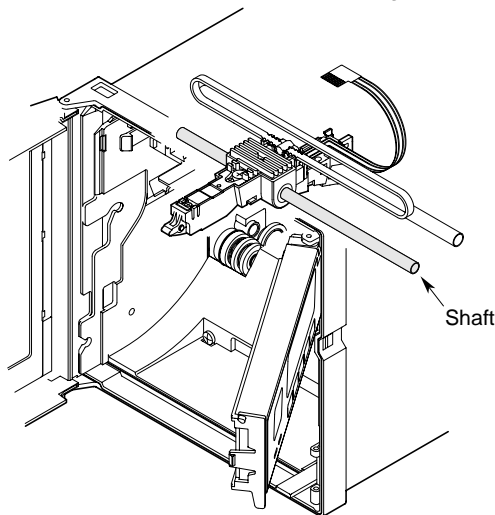

5.2 Fuse

WARNING

Don't replace the fuse by yourself. Never take the recorder apart if the fuse needs to be replaced.

Contact your nearest Omega sales representative if the fuse needs to be replaced.

Fuse Ratings

Rated Voltage:	250V
Rated Current	1.25A
Type:	Time Lag
Approved Standard:	IEC/VDE

6.1 Error Messages

This chapter describes the causes and recovering methods of recorder errors.

Error Code List

Error Codes	Meaning	Recovery	
Er n_db1	Main memory reading error.	Contact OMEGA Engineering.	
Er n_db2	Main memory writing error.		
Er A_db1	A/D converter memory reading error.		
Er A_db2	A/D converter memory writing error.		
Er AdAdJ	Calibration data error of A/D converter.		
Er rOn	System ROM failure.		
Er rAn	System RAM failure.		
Er rbn	Ribbon shift, ribbon feed failure (dot model).		
Er rpn	Printer failure (dot model).		
Er S_db□	Range memory reading/writing error.		
Er001	System failure.		
Er002	Entered value exceeds allowable setting range.		Enter correct data.
Er007	Wrong password.		Enter the correct password.
Er012	Attempt to replace pen ([_ PEN) while recording.		Stop recording.
Er045	Span L and span R have the same value.		Change the span value. See Section 2.1.
Er046	Scale l and scale r have the same value .		Change the scale value. See Section 2.1.
Er060	Attempt to set alarm to a SKIPPed channel.		Set the alarm setting to OFF. See Section 2.2.
Er200	Attempt to set the offset value to a SKIPPed channel.		Set the offset protection OFF. See Section 3.8.
Er201	Offset is a value surpassing 10% of the recording span.		Enter the correct value.

6.2 Troubleshooting

- Errors exceed specified limits
- Measuring value indications fluctuate
- Pen/printer carriage goes off-scale at 0% or 100%.

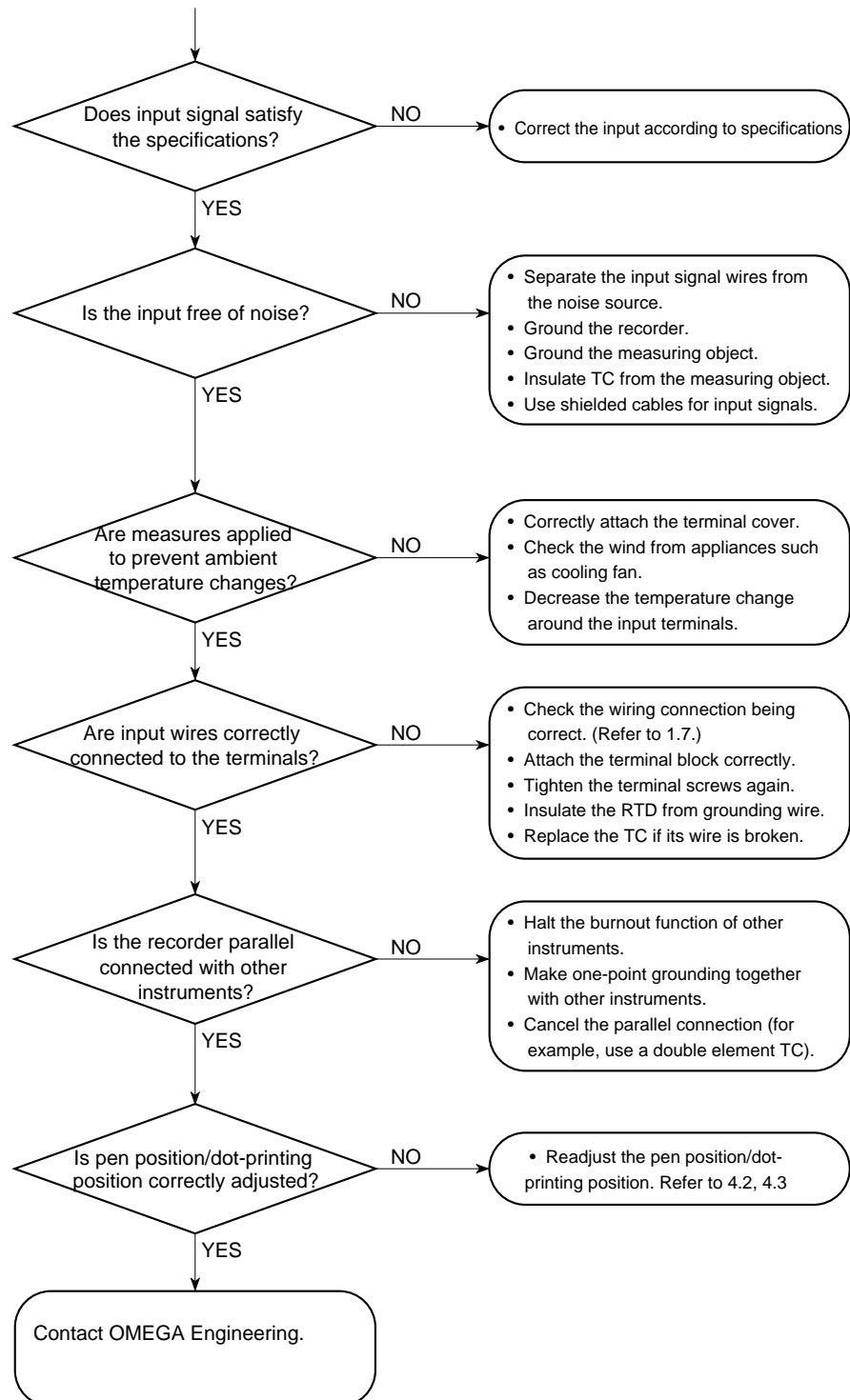

• Recorder is completely inoperative

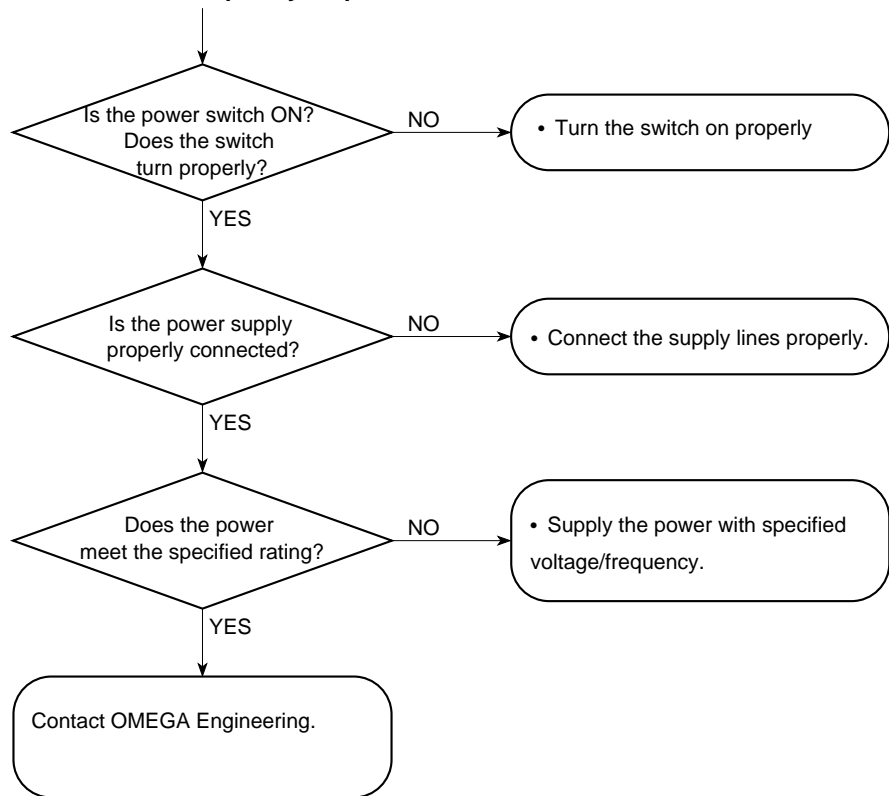

• Glitch found other than the above mentioned:

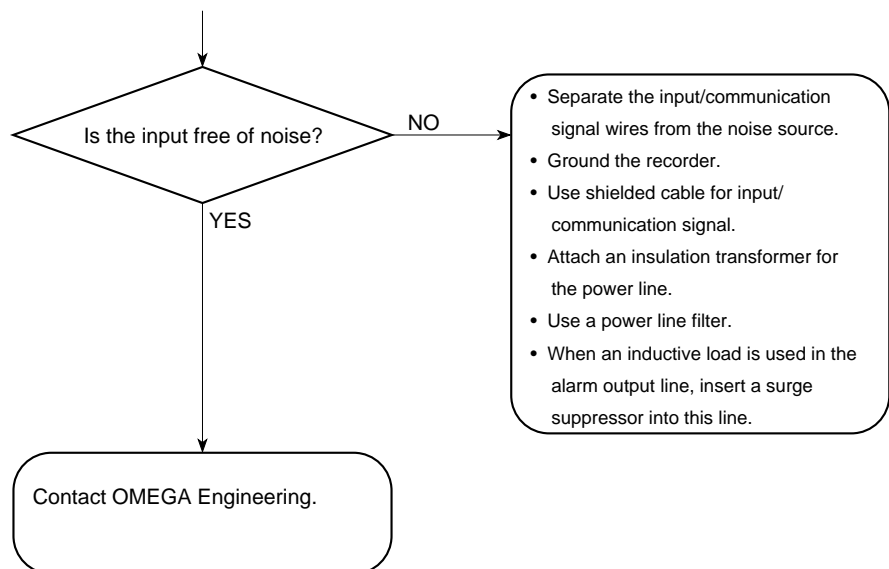

Index

A

A/D Integration Time	3-6
Accessories	1-1
Adjustment	
of Dot-Position (Dot Model)	4-5
Alarm	
Functions	2-8
Hysteresis	3-5
Output Wiring	1-14
AUTO mode	2-11

B

B_Out	3-7
B_Set	3-7
Basic (SETUP) Settings	
Flow Chart	3-2
Introduction to	3-1
Burnout Registration	3-7

C

C_Spd	3-14
Calibration	
Execution	4-2
Operation Conditions	4-2
Wiring	4-1
Carriage Shafts	5-1
Celsius	3-13
CH UP key	1-4
Characters on Display	1-5
Chart Speed adjustment	2-10
Chart Speed Trigger	3-14
Cleaning	5-1
Color	3-12
Colors for Channel Printing (Dot Model)	3-12

D

D2 Option	3-13
DC current input	1-13
DC voltage Inputs	1-13
De_En	3-4
Deg_C	3-13
Deg_F	3-13
Dimensions	1-9
DISP key	1-4
Display	1-4
Dot-Position Adjustment	4-5
DOWN	3-7

E

Energ	3-4
Energizing (-de) Alarm Output Relays	3-4
ENT key	1-4
Error Code List	6-1
ESC key	1-4

F

Fahrenheit	3-13
FEED key	1-4
Filter for Noise Input	3-8
FIX	2-11
Full	4-3, 4-4, 4-5
Functions	1-4

H

Hys	3-5
-----------	-----

I

Init	3-16
Initializing Settings	3-16
Input	
Range Setting	2-3
Signal Wiring	1-12
terminal for RTD	4-1
terminals (for DC voltage or TC)	4-1
Installation Site	1-7
Intg	3-6

L

Lock	3-15
------------	------

M

M_Ave	3-9
Model Codes	1-3
Moving Average Calculation	3-9

N

Noise Input Filter	3-8
Null	4-3, 4-4, 4-5

O

Offset	
Setting	3-11
Value Security Lock	3-10
Ofst	3-11

P

P_Adj	4-3, 4-5
Packings	1-2
Password	3-15
Power Supply Wiring	1-11
Power terminals	4-1
Printing Interval	2-11

R

R1 option	3-14
Range	2-3, 2-4, 2-5
RCD key	1-4
Rear Panel	1-5
Rear Panel Arrangement	1-10
Recording Span Setting	2-3
Recording Trigger	3-14
Regular Settings	
Flow Chart	2-2
Introduction to	2-1
Relay	3-4
Relay Option Alarm Settings	2-9
Rem	3-14
Remote Control Wiring	1-15
Resistance Temperature Detector Setting	2-5
RTD	2-3, 2-5, 4-1
RTD input	1-13

Index

S

Scale Setting	2-6
SCL	2-3, 2-6
SKIP	2-3

T

TC	2-3, 2-5
TC input	1-13
Temp	3-13
Temperature Unit Selection	3-13
Terminal Board	1-13
Thermocouple	2-5
Trigger	
for Chart Speed	3-14
for Recording	3-14

U

Unpacking	1-1
UP	3-7

V

VOLT	2-3
Voltage Measurement Setting	2-4

W

Wiring	1-10
for Alarm Output	1-14
for Calibration	4-1
for Input Signal	1-12
for Input Terminals	1-13
for Power Supply	1-11
for Remote Control	1-15

WARRANTY / DISCLAIMER

OMEGA ENGINEERING, INC. warrants this unit to be free of defects in materials and workmanship for a period of 25 months from date of purchase. OMEGA Warranty adds an additional one (1) month grace period to the normal two (2) year product warranty to cover handling and shipping time. This ensures that OMEGA's customers receive maximum coverage on each product.

If the unit malfunctions, it must be returned to the factory for evaluation. OMEGA's Customer Service Department will issue an Authorized Return (AR) number immediately upon phone or written request. Upon examination by OMEGA, if the unit is found to be defective, it will be repaired or replaced at no charge. OMEGA's WARRANTY does not apply to defects resulting from any action of the purchaser, including but not limited to mishandling, improper interfacing, operation outside of design limits, improper repair, or unauthorized modification. This WARRANTY is VOID if the unit shows evidence of having been tampered with or shows evidence of having been damaged as a result of excessive corrosion; or current, heat, moisture or vibration; improper specification; misapplication; misuse or other operating conditions outside of OMEGA's control. Components which wear are not warranted, including but not limited to contact points, fuses, and triacs.

OMEGA is pleased to offer suggestions on the use of its various products. However, OMEGA neither assumes responsibility for any omissions or errors nor assumes liability for any damages that result from the use of its products in accordance with information provided by OMEGA, either verbal or written. OMEGA warrants only that the parts manufactured by it will be as specified and free of defects. OMEGA MAKES NO OTHER WARRANTIES OR REPRESENTATIONS OF ANY KIND WHATSOEVER, EXPRESS OR IMPLIED, EXCEPT THAT OF TITLE, AND ALL IMPLIED WARRANTIES INCLUDING ANY WARRANTY OF MERCHANTABILITY AND FITNESS FOR A PARTICULAR PURPOSE ARE HEREBY DISCLAIMED. LIMITATION OF LIABILITY : The remedies of purchaser set forth herein are exclusive, and the total liability of OMEGA with respect to this order, whether based on contract, warranty, negligence, indemnification, strict liability or otherwise, shall not exceed the purchase price of the component upon which liability is based. In no event shall OMEGA be liable for consequential, incidental or special damages.

CONDITIONS: Equipment sold by OMEGA is not intended to be used, nor shall it be used: (1) as a "Basic Component" under 10 CFR 21 (NRC), used in or with any nuclear installation or activity; or (2) in medical applications or used on humans. Should any Product(s) be used in or with any nuclear installation or activity, medical application, used on humans, or misused in any way, OMEGA assumes no responsibility as set forth in our basic WARRANTY/DISCLAIMER language, and, additionally, purchaser will indemnify OMEGA and hold OMEGA harmless from any liability or damage whatsoever arising out of the use of the Product(s) in such a manner.

RETURN REQUESTS / INQUIRIES

Direct all warranty and repair requests/inquiries to the OMEGA Customer Service Department. BEFORE RETURNING ANY PRODUCT(S) TO OMEGA, PURCHASER MUST OBTAIN AN AUTHORIZED RETURN (AR) NUMBER FROM OMEGA'S CUSTOMER SERVICE DEPARTMENT (IN ORDER TO AVOID PROCESSING DELAYS). The assigned AR number should then be marked on the outside of the return package and on any correspondence.

The purchaser is responsible for shipping charges, freight, insurance and proper packaging to prevent breakage in transit.

FOR WARRANTY RETURNS, please have the following information available BEFORE contacting OMEGA:

1. Purchase Order number under which the product was PURCHASED,
2. Model and serial number of the product under warranty, and
3. Repair instructions and/or specific problems relative to the product.

FOR NON-WARRANTY REPAIRS, consult OMEGA for current repair charges. Have the following information available BEFORE contacting OMEGA:

1. Purchase Order number to cover the COST of the repair,
2. Model and serial number of the product, and
3. Repair instructions and/or specific problems relative to the product.

OMEGA's policy is to make running changes, not model changes, whenever an improvement is possible. This affords our customers the latest in technology and engineering.

OMEGA is a registered trademark of OMEGA ENGINEERING, INC.

© Copyright 1998 OMEGA ENGINEERING, INC. All rights reserved. This document may not be copied, photocopied, reproduced, translated, or reduced to any electronic medium or machine-readable form, in whole or in part, without the prior written consent of OMEGA ENGINEERING, INC.

Where Do I Find Everything I Need for Process Measurement and Control? OMEGA...Of Course!

TEMPERATURE

- Thermocouple, RTD & Thermistor Probes, Connectors, Panels & Assemblies
- Wire: Thermocouple, RTD & Thermistor
- Calibrators & Ice Point References
- Recorders, Controllers & Process Monitors
- Infrared Pyrometers

PRESSURE, STRAIN AND FORCE

- Transducers & Strain Gauges
- Load Cells & Pressure Gauges
- Displacement Transducers
- Instrumentation & Accessories

FLOW/LEVEL

- Rotameters, Gas Mass Flowmeters & Flow Computers
- Air Velocity Indicators
- Turbine/Paddlewheel Systems
- Totalizers & Batch Controllers

pH/CONDUCTIVITY

- pH Electrodes, Testers & Accessories
- Benchtop/Laboratory Meters
- Controllers, Calibrators, Simulators & Pumps
- Industrial pH & Conductivity Equipment

DATA ACQUISITION

- Data Acquisition & Engineering Software
- Communications-Based Acquisition Systems
- Plug-in Cards for Apple, IBM & Compatibles
- Datalogging Systems
- Recorders, Printers & Plotters

HEATERS

- Heating Cable
- Cartridge & Strip Heaters
- Immersion & Band Heaters
- Flexible Heaters
- Laboratory Heaters

ENVIRONMENTAL MONITORING AND CONTROL

- Metering & Control Instrumentation
- Refractometers
- Pumps & Tubing
- Air, Soil & Water Monitors
- Industrial Water & Wastewater Treatment
- pH, Conductivity & Dissolved Oxygen Instruments