



## ***OzonyMed***

# OZONE BACTERICIDE (Ozonizer) USER'S MANUAL



- 
- The unit must be installed by certified dental engineers and operated by licensed medical professional only.
  - Read all instructions in this USER'S MANUAL BEFORE installation or operation.

# TABLE OF CONTENTS

<b>1. PRESENTATION</b>	<b>3</b>
Formation of Ozone	
Properties of Ozone	
Biochemicals Basis of Ozone Reactions	
Ozone Action Models	
<b>2. SAFETAY INSTRUCTIONS and CONTRAINDICATIONS</b>	<b>4</b>
Safety Instructions	
Contraindications	
Safety & Health Standards	
<b>3. ADVANTAGES</b>	<b>7</b>
<b>4. CONSTITUTION and PANEL FIGURES</b>	<b>7</b>
Constitution	
Control Panel	
Probes	
<b>5. INSTALLATION and OPERATION</b>	<b>8</b>
Applicable Scope	
I. Department of Gingiva:	
❖ Gingival Pocket Treatment	
❖ Gingival Surgery Applications	
❖ Necrotizing Gingivitis Treatment	
❖ Pericoronitis Treatment	

II. Maintenance & Preventive Treatment:

- ❖ Dental Cavity Disinfections
- ❖ Root Canal Disinfections
- ❖ Tooth Root Disinfections
- ❖ Oral Candidiasis Treatment
- ❖ Herpetic Treatment
- ❖ Treatment of Aphtha
- ❖ Stomatitis Treatment
- ❖ CP & P Therapy

III. Jaw Surgery Applications:

- ❖ Pre-operative Extensive Oral Disinfections
- ❖ Post-operative Oral & Wound Disinfections
- ❖ Wound Inflammation Treatment
- ❖ Hemostasis of Oozing Hemorrhage
- ❖ Tooth Extraction Follow-up Treatment

Indications Form

<b>6. MAINTENANCE</b>	<b>14</b>
<b>7. TROUBLE SHOOTING</b>	<b>14</b>
<b>8. SPECIFICATION and ACCESSORIES</b>	<b>15</b>
<b>9. WARRANTY</b>	<b>15</b>

**NOTE**

Use only the specified accessories.



: Read before use.



: Type BF applied part.



: Double insulated equipment.

## **1. PRESENTATION**

The main purpose of this unit is to produce pure ozone in localized regions for medical treatment. Due to its unique effects, it can reach a concentration ranging from 10 to more than 100µg/ml required for the treatment areas. The properties of pure ozone in sanitize fungi, viruses, and bacteria, make the unit into a novel and important therapeutic tool in dental treatment, with the hopes of resisting illnesses that are caused by bacteria, such as gingivitis. Moreover, ozone is a strong oxidizing agent currently used nowadays, and has a strong sterilizing power so that it can even disinfect tough bacteria, fungi, and viruses.

The level of ozone therapy is related with two processes. One is the conversion of ozone into oxygen when oxygen molecules are present. Another one is the process through hydrogen peroxide (H<sub>2</sub>O<sub>2</sub>). Subsequently, the longer the ozone therapy is conducted, the results been achieved from therapy is greater.

### **FORMATION OF OZONE**

Ozone is formed by ultraviolet radiation and electron conversion of oxygen (with a chemical formula of O<sub>2</sub>) molecules in order to form ozone (with a chemical formula of O<sub>3</sub>). The ozone layer in the atmosphere can protect people from harm caused by UV radiation from the sun. Moreover, the ozone layer on the earth's surface can be taken an index of air pollution, because the ozone value increases under aggravated air pollution and direct exposure to sunlight.

### **PROPERTIES OF OZONE**

Ozone is a poignant gas. If a high concentration of ozone is inhaled, this will cause injuries to the human body. The inhaled ozone will inflict injuries to the lungs, come into contact with the eyes, or irritate the mucous membrane.

The German government stipulates that the maximum workplace concentration of ozone (i.e. MAK value) shall not exceed 0.2mg/m<sup>3</sup> for a weekly inhalation of 42 hours and a daily inhalation of 8 hours. At just one tenth of the MAK value, the odor of ozone can be perceived. However, within a shorter inhalation period, a higher concentration of ozone is allowed. Once formed, ozone will quickly be absorbed into oxygen molecules. Studies have shown that low ozone concentration actually does not harm the human body but has a therapeutic effect.

Like numerous medications, ozone has different effects under a different concentration. For example, ozone in a low concentration can promote blood circulation and stimulation; ozone in a slightly higher concentration can stop bleeding, disinfect, and inhibit substances.

### **BIOCHEMICAL BASIS OF OZONE REACTIONS**

After observing the sterilization action of ozone water, it is found that oxidation is primarily the action on the constantly dripping water drainage. In other words, when microbes come into contact with a sufficient amount of ozone, this will produce sterilization effects. Through oxidation, the cell envelopes of microbes are decomposed, and then their DNA or RNA is also attacked, in order to kill bacteria or viruses; such observations have already been proposed by several scholars. If such observations have been applied in medical treatment, they are considered localized ozone actions.

Moreover, in order to achieve the best disinfection and sterilization action within a short treatment period as far as possible, only a high concentration (>40µg/ml) of ozone is applied in localized regions. Like industrial sewage disposal and wound treatment, its sterilization action on bacteria and viruses is based on the oxidation power (E<sub>0</sub>=2.07V; that

is Energy Level) of ozone, which is related to the molecular structure of ozone. As its electron density is high, ozone in the gaseous state will be decomposed into the oxygen in the atmosphere (similar to H<sub>2</sub>O, that is water.) During its transition, an oxygen atom will escape, thereby producing oxidizing properties, which is a mechanism for wound healing.

As for cellular healing, oxidation action will deactivate viruses, and discharged peroxides which produce synergism within the cells and kill the microbes that invade into cells. As a rule, inflammation will occur only when white blood cells no longer can kill bacteria, so that hydrogen peroxide (H<sub>2</sub>O<sub>2</sub>) is unable to be produced or a less than normal quantity of hydrogen peroxide is produced.

**OZONE ACTION MODELS**

Concentration (in µg/ml)	Applications	Indications	Ozone Actions
80-100	Localized treatment	Wound superinfections, colitis, fungal infection	Decomposing and sterilizing bacteria by oxidation
40-80	Localized treatment	Poor wound healing, proctitis, rectal fissure & fistula	Sterilization by the deactivation achieved through oxidation
10-40	Systematic treatment	Blood circulation disturbance, viral illnesses, geriatric medical treatment, allergic and malignant illnesses	Being restored by the oxidation of O <sub>2</sub> metabolism

**Remark:**

High-concentration ozone can arrest hemorrhage whereas low-concentration ozone can promote blood circulation.

**Ozone Decomposition:**

Half-life is the time required for decomposing half of a substance; this can be taken for reference as the speed of decomposing a substance at different temperatures. As ozone is a high-energy compound, and its decomposition speed is very fast, a mixture of ozone and oxygen is unable to be kept stable on a long-term basis (A mixture of ozone and oxygen in a water-containing utensil can be kept for 30 minutes at 25°, but for 300 minutes at -10°.) and is thus produced only immediately during medical treatment.

**2. SAFETY INSTRUCTIONS and CONTRAINDICATIONS**

Prior to use, it is imperative that the instruction manual and safety standards has been read thoroughly.

**SAFETY INSTRUCTIONS**

1. Before using the equipment for the first time, it is important that the probe to be cleaned and disinfected.
2. This equipment shall not be used in a moist environment.
3. Operator without receiving proper training shall not operate this equipment.
4. It is necessary for each treatment to conform to the safety standards specified for dental treatment.

For the equipment and its probes, please refer to “SAFETY and HEALTH STANDARDS”.

5. It is necessary to be familiar with indications and contraindications of ozone therapy.
6. No alcohol or ether shall be used, because these two solutions are combustible in electro surgery.
7. It is suggested that empirical values can be taken as intensity values primarily used for therapy. The release of an electric current will not cause any injuries to the human body as long as a contraindication is not involved.
8. When an electric current passes through an allergic patient, the patient may have a trembling feeling, especially when the patient’s lips come into contact with probe. However, the probe handle has been highly insulated.
9. It is best suggested that the foot pedal to be used. For example, when the probe comes into contact with the to-be-treated “area” inside the gingival pocket. Start the unit with foot pedal and by the end of the treatment, while the probe is still in contact or within the mouth, the foot pedal can be used to stop the treatment. Its advantage lies in its capability to avoid overly sensitivity (that is, the patient’s tactile sensation of the electric current when coming into contact with the current.)
10. The Safety Rod at the patient’s end for dental treatment conforms to the regulations stipulated by manufacturers. All treatment specifications, especially data related to time and power, are all related to the Safety Rod at the back of the unit. We sincerely suggest that the patient to hold the Safety Rod, especially during using the No. 1 probe, so that it is possible to recognize any fracture at the tip of the probe caused by negligence during therapy, and thus for stopping the signals immediately. When the Safety Rod is connected, the power output will reduce to half of the selected only.
11. Electro surgery is a treatment in which the to-be-treated area is treated by probe sparking (For example, while applying probes in pus treatment, the probes are kept at a distance of 1 mm apart.)
12. The probe shall not come into contact with the open eyes or shall not be placed at close range to the eyes.
13. In order to enable the NO. 1 probe to penetrate into the gingival pocket, its diameter at the tip is set to be approximately 1.5mm, so as to avoid excessive force or a lever action (to prevent it from being broken.) Hence, it is necessary to widen the gingival pocket prior to using as the probe is secure for general applications in gingival pocket treatment. If the probe really breaks, the unit power will automatically be cut off within 0.1 second at a power level of 2.
14. Once the unit is in operation and all the probes are functioning, a red color lighting will be displayed within the probe.
15. No foreign substance shall be plugged into the opening of the equipment or the opening of the probe!

#### **CONTRAINDICATIONS**

For the following conditions, the unit should not be used or can only be used under specific conditions:

1. Patients using cardiac stimulators (pacemakers).
1. Epileptic patients or patients suffering from other serious neurological illnesses.
2. Patients suffering from psychological problems.
3. Mucous membrane of infants (under one year old).
4. Patients who are overly sensitive to electric currents.
5. Patients suffering from serious asthma.
6. Pregnant women.

This therapy will not have any negative effects on the illnesses specified in the above-mentioned contraindication No. 2, 3, 5, and 6. These are considered contraindications merely because these may produce uncontrollable secondary mechanical reactions.

To those patients suffering from contraindication No. 1, it is only possible to apply a light electric current for the therapy because this electric current will not cause any interference to a normally functioning cardiac stimulator.

To those patients suffering from the contraindication No. 4, it is not possible to apply an electric current at a power level above 2. To the patients suffering from the contraindication No. 7, the important notes are the same as those for contraindication No. 4. Moreover, dentists shall decide whether those suffering from the above-mentioned contraindications should receive therapy.

#### **SAFETY and HEALTH STANDARDS**

Ozone is applied for localized therapy. Its concentration is required to be within acceptable medical range. For the probe and the outside of the skin, ozone thus generated is required to be diluted with the surrounding air at a level of less than 4 times of the MAK value at  $0.2\text{mg}/\text{m}^3$  (i.e. the average workplace concentration of ozone stipulated by the German government.)

Moreover, the ozone values generated inside the oral cavity also show that they are below the MAK values, so that even if they are inhaled (inside the therapy room) for a short time, it will not have any injury on the respiratory tract. However, it is necessary to avoid an extended direct inhalation of ozone within the treatment range, which may stimulate the respiratory tract and mucous membrane for allergic patients. Consequently, it is suggested that the therapy room should be well ventilated and moreover, the glass probe should be prevented from directly coming into contact with emulsion gloves, because some products have poor tolerance toward ozone, which may thus damage the emulsion layer of the gloves.

Once using it, the unit should be cleaned every time. A wet cloth sprayed with disinfectant is required to wipe the manually operated equipment. Moreover, water is absolutely not allowed to flow into the equipment. Once using it, the probe is required to be disinfected by disinfectant after every therapy.

Surgery applications: sterilization is required (When proceeding with sterilization with solutions, metallic probe parts shall not be soaked into solutions.) After being dried, functional tests are required for the equipment. **However, steam sterilization is not covered by warranty, because this sterilization process will shorten the service life of equipment during sterilization.**

Moreover, only original accessories made by the original manufacturer should be used. This includes probes and plug-connected parts. Hence, only the accessory

plug-connected parts can be used.

Glass probes have major safe functionalities. Consequently, non-packaged accessories or other probes not supplied by manufacturers shall not be used for this equipment.

### 3. ADVANTAGES

Nowadays, ozone is primarily applied for disinfection and promoting localized blood circulation as a free-flowing agent and spray, in the form of ozone water for dental treatment. However, its drawbacks lie in that the saturation of ozone is low, and its decomposition rate is too rapid, this frequently affects its achievability to cure. Another drawback of ozone is that it easily irritates the pharynx and the mucous membrane of the nasal cavity when ozone solutions and sprays are used.

However, this unit can prevent these drawbacks and achieve the effects expressed by highly concentrated ozone. In other words, when probes come into contact with the to-be-treated area, they will generate ozone especially for the area. Hence, the therapeutic effects provide you with a strong disinfection effect and can arrest the oozing hemorrhage, so that it has a cleaning therapeutic effect on the affected area, improving the localized oxygen supply to the wounds, rapid healing of wounds and increase the temperature of localized tissues by speeding up metabolism.

### 4. CONSTITUTION and PANEL FIGURES

#### CONSTITUTION

- A : Control Box
- B : Ozone Generating Handpiece
- C : Safety Rod (Ground Wire)
- D : Foot Pedal Switch
- E : Switching Power Adapter
- F : Probe

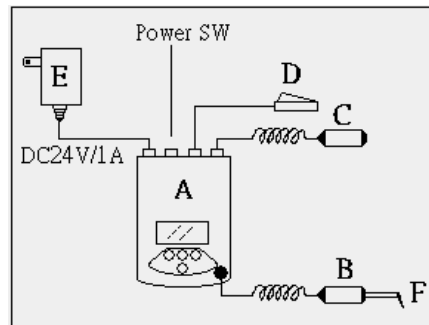

#### CONTROL PANEL

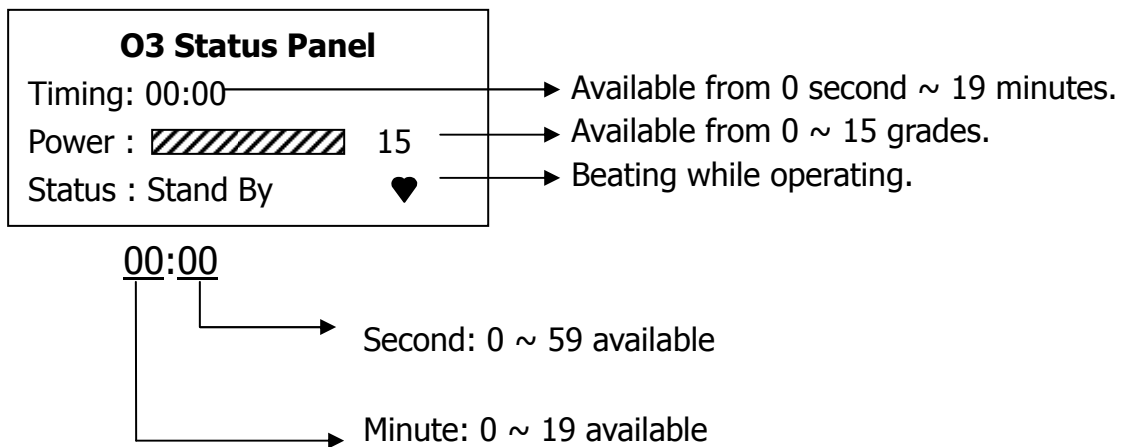

- ⏮: DOWN
- ⏭: UP
- ⏻: ON / OFF
- ⏵: ENTER





## PROBES

### No. 1 Probe

Pointed probe 10° , generally for treatments of gingivitis.

### No. 2 Probe

Pointed probe 50° , generally for treatments of gingivitis.

### No. 3 Probe

Flat probe, for treatments of skin and mucous membrane

### No. 4 Probe

Conical probe, for alveolar therapies after tooth extraction

### No. 5 Probe

Pointed probe 10° with conical plastic, for root canal treatments



## 5. INSTALLATION and OPERATION

1. Connect properly the Safety Rod, the foot pedal, and the switching power adapter with the control box.
2. Assure the electric power on the unit is turned off.
3. Clean and disinfect the selected probe and the ozone handpiece.
4. Screw properly the ozone handpiece with the control box.
5. Slightly and properly insert the selected probe into the probe seating on the ozone handpiece.
6. Pre-operation test of function as the following:
  - (1) Turn on the power.
  - (2) Press to set the timing by pressing or . Press to go on next.
  - (3) Set the power at level 5. Press to save the setting.
  - (4) Put the probe close to the arm by keeping around 1mm from the skin. Press to start program.
  - (5) Gas inside the probe turns slight red color while operating.
  - (6) There's a sparking sound and ozone smell on the skin.
7. When the probe is broken, it will be automatically cut off within 0.1 second and the switch will then be turned off. In order to enable the automatic cut-off mechanism to achieve its function, the Safety Rod must be held in hand of patient. This can thus prevent allergic patients from feeling trembling.
8. The foot pedal has the same function as (on / off).

9. For power-related information, please refer to **Applications & Indications Table**.
10. Operation can be started after checking the above instructions.
11. **Gradually increase the output power to meet with patient's comfort.**
12. By the end of therapy, it is imperative to turn off the power of the unit.
13. Apply a force slightly and then screw out the glass probe in a clockwise direction.
14. Clean the unit and probe (referring to **Maintenance & Repairs** ) and then carefully return all the parts to their original locations.

### **APPLICABLE SCOPE**

When the probe comes into contact with the focus, for example, during the therapy of gingivitis, oxygen will be converted into ozone inside and on the surface of gingiva, because oxygen molecules can also be oxidized in solutions. Consequently, it can arrest the oozing hemorrhage, relative to traditional therapy, so that therapy can be continued. Moreover, a high-frequency electric current can promote lymph flow and metabolism on the to-be-treated focus. Furthermore, a wide range of replaceable probes is used so that probes can extend to the source of the illness and thus achieve the required sterilization effect. Hence, the unit can be described to achieve its effects as follows:

#### ※ IMPORTANT NOTE※

1. We suggest that an aspirator should be used together with the unit during therapy, so that free ozone molecules are separated.
2. **Gradually increase the output power to meet with patient's comfort.**

Oxidation reaction rate means the conversion of oxygen molecules per time unit, which is related to pH value. In an alkaline environment, oxidation reaction is faster but is slower in an acidic environment. Consequently, we suggest that an oxygen accelerator is used together with this equipment in an acidic therapeutic environment. For the oxidization accelerator, substances containing catalytic copper ions can be used.

## **I. DEPARTMENT OF GINGIVA**

### ❖ **Gingival Pocket Treatment**

NO. 1 probe is at a diameter of approximately 1.5mm at the tip and at approximately 8 mm by length. Its glass tip is secure and is not easily broken for normal usage, for example at the gingival pocket. In order to prevent the probe from being broken, please don't over-exert a force and a lever action on the probe.

Set the output power at level 3~6. Prior to the insertion of the probe, it is necessary to open the gingival pocket, so that oxygen molecules can enter the to-be-treated focus. Then the probe is extended into the opened gingival pocket. However, it is not necessary to extend the tip to the bottom of the gingival pocket, because through the conversion of oxygen, ozone will rapidly diffuse in the opened gingival pocket.

As a rule, it takes 1 to 2 minutes for the treatment of every to-be-treated focus, so that the bacteria at that to-be-treated focus can become oxidized, thereby killing the bacteria. A thorough gingivitis therapy covers both gingival pocket therapy and gingival therapy outside the gingival pocket; as for this therapy,

Using No. 3 probe, set the output power at level 3~9 for the same timing on the to-be-treated focus. It is suggested to repeat the same therapy a few days later, until gingivitis recedes noticeably. Moreover, it is also suggested that regular preventive treatment should be conducted every half year.

#### ❖ **Gingival Surgery Applications**

Use the NO. 1 and NO. 3 probes. Set the output power at the same level as gingival pocket treatment, and the timing at 1 minute for each treatment. In order to assure that the wider opening can receive a sufficient ozone concentration, it is necessary to select longer action timing than that required for gingival pocket treatment.

#### ❖ **Necrotizing Gingivitis Treatment**

Use the NO. 1 and NO. 3 probes with reference to the size of to-be-treated focus. Set the output power at level 3~6, and the timing at 2 minutes for each treatment so that the pus-filled portion can become fully oxidized. It is suggested that follow-up therapy should be conducted three days later.

#### ❖ **Pericoronitis Treatment**

For serious dental caries, use the NO. 3 or NO. 1 probe, setting the output power at level 3~6 for timing 1~3 minutes. For the treatment, ozone that inhibits inflammation, as well as a high-frequency electric current that promotes blood circulation and lymphatic fluid, is applied. After treatment, patient's symptoms are relieved.

## **II. MAINTENANCE & PREVENTIVE TREATMENT**

#### ❖ **Dental Cavity Disinfection**

Use NO. 4 and NO. 1 probes with reference to the size and shape of the to-be-treated focus.

It is more suitable to extend NO. 4 probe to the to-be-treated focus for the cavity formed by tooth extraction. As for the dental cavity with a smaller opening, it is more suitable to dispose the NO. 5 probe in the opening, so that ozone can be diffused in the cavity. It is suggested to set the output power at level 3~9, and timing at 1.5~3 minutes. As for bleeding cavities, it is suggested to set the output power at level 12, and timing approximately at 5 minutes based on the severity of bleeding.

### ❖ **Root Canal Disinfection**

Use NO. 1 probes. Prior to ozone therapy, it is necessary to remove the residual soft tissues inside the root canal, so that oxygen molecules can enter the root canal. Then the NO. 5 probe is slightly extended into the root canal. Set the output power at level 6, and timing at 0.5~1 minute.

Moreover, it is possible to use the NO. 1 probe, but care should be taken to prevent the probe from being stuck and in order to prevent the tip of the probe from being broken while patient is moving. Ozone will then diffuse to all the branches and kill the bacteria.

### ❖ **Tooth Root Disinfection**

Use the NO. 3 and NO. 4 probes. Place the probe on the tooth root, and set the output power at level 6~9, and timing at 0.5 minute.

### ❖ **Oral Candidiasis Treatment**

Place the NO. 3 probe along the affected focus for therapy. Set the output power at level 6. When the probe is at a resting state, set the timing acting for 2 minutes for every 8mm<sup>2</sup> of the to-be-treated focus. It is suggested that therapy is repeated twice several days later.

### ❖ **Herpetic Treatment**

Place the NO. 3 probe along the affected focus for therapy. Set the output power at level 6~9. When the probe is at a resting state, set the timing acting for 0.5~1 minute for every 8mm<sup>2</sup> of the to-be-treated focus. It is suggested that therapy is administered twice daily until the condition turns good. Therapeutic effects will appear after therapy has been administered for several times. However, viral nervous necrosis (Type 2 / Herpes Zoster) may take a longer therapeutic time.

### ❖ **Treatment of Aphtha**

Place the NO. 3 probe along the affected focus for therapy. Set the output power at level 6~9. When the probe is at a resting state, set the timing acting for 0.5~1 minute for every 8mm<sup>2</sup> of the to-be-treated focus. It is suggested that therapy is administered twice daily for the first few days. Therapeutic effects will appear after therapy has been administered for several times. However, keratinized aphtha (herpes zoster) may take a longer therapeutic time.

### ❖ **Stomatitis Treatment**

Place the NO. 3 probe along the affected focus for therapy. Set the output power at level 9. When the probe is at a resting state, set the timing acting for 1 minute for every 5mm<sup>2</sup> of the to-be-treated focus. It is suggested that therapy is administered twice several days later.

#### ❖ **CP & P Therapy**

Use the NO. 1, NO. 4, or NO. 3 probe to further sterilize the dental cavity after dental caries have been treated. Set the output power at level 6 and timing approximately for 0.5~1 minute with reference to the size of cavity. Especially for pulp therapy (endodontics), once the caries have been incised and extracted, power at level 12 is able to alleviate the blocking caused by homeostasis and thus increases the success rate of alleviating the inflamed focus.

### **III. JAW SURGERY APPLICATIONS**

#### ❖ **Pre-operation Oral Disinfections**

Use the NO. 3 probe. Set the output power at level 3~9 for treatment of entire oral cavity. It takes approximately 10 minutes to complete the treatment (with long-term action timing).

#### ❖ **Post-operation Oral & Wound Disinfections**

Use NO. 3 probe. Set the output power at level 6~9 for treatment of entire oral cavity. It takes no less than 3~10 minutes to complete the treatment (with medium to long-term timing). A shorter therapeutic timing can be selected for individual wounds.

#### ❖ **Wound Inflammation Treatment**

Place NO. 3 probe along the affected focus for therapy. Set the output power at level 9. When the probe is at a resting state, set the timing acting for 1 minute for every 5mm<sup>2</sup> of the to-be-treated focus. It is suggested that therapy is repeated twice on the next day.

#### ❖ **Homeostasis of Oozing Hemorrhage**

Use NO. 4 or NO. 1 probe to arrest the oozing gingival hemorrhage. Use the AV probe for the hemorrhage in the dental cavity, setting the output power at level 9~15 for timing 1~5 minutes.

#### ❖ **Tooth Extraction Follow-up Treatment**

Use NO. 4 probe. It is suggested to extend the probe into the dental cavity in order to prevent inflammation. Set the output power at level 9 for timing 1~2 minutes.

#### **INDICATIONS FORM**

The applications of this form are excerpted from **Applicable Scope** on the Instruction Manual. The time used, intensity settings, and the frequency of repeating the treatment can provide average empirical values for your reference. However, the values may change with reference to the size of the area of the focus, pH value, and the severity of illnesses. Moreover, dentists should decide the individual intensity used for therapy.

<b>Diagnosis</b>	<b>Probe Type</b>	<b>Output Power</b>	<b>Time</b> (in seconds)	<b>Frequency</b> (Repeated)	<b>Days</b>
Gingival Pocket Therapy	No. 1 No. 3	3~6	60 / tooth	Once to twice per week, three days later	3~5
Gingival Treatment	No. 1 No. 3	3~9	10/cm <sup>2</sup>	Once to twice per week, three days later	3~5
Gingival Surgery Applications	No. 1 No. 3	3~9	40 / tooth	Once per week, three days later	2~5
Necrotizing Gingivitis Treatment	No. 1 No. 3	3~6	40	Once per week, three days later	5
Pericoronitis Treatment	No. 3	3~6	60 / tooth	Twice per week	1
Dental Cavity Disinfections & Dental Cavity Hemorrhage Treatment	No. 3 No. 4 No. 5	3~6 12	30/Kav 30/Kav	Once Twice	1 2
Root Canal Disinfections	No. 5	6	40 / root Canal	Once	2
Tooth Root Disinfections	No. 3 No. 4	6~9	20 / tooth root	Once	1
Oral Candidiasis Treatment	No. 3 No. 4	6	10/cm <sup>2</sup>	Twice per week	3~5
Treatment of Aphtha	No. 3 No. 4	6~9	40 / aphtha	Twice per week	1~3
Herpetic Treatment	No. 3 No. 4	6~9	20 / herpe	Twice per week	1~3
Stomatitis Treatment	No. 3	9	10/cm <sup>2</sup>	Twice	3
Dental Caries Treatment (CP, P)	No. 1 No. 4 No. 5	6	40	Once	1
Neuro-therapy	No. 3 No. 4	9	30	Twice per week	3~5
Pre-operative Extensive Oral Disinfections	No. 3	3~9	10/cm <sup>2</sup>	Once	1
Post-operative Oral & Wound Disinfections	No. 1 No. 3	6~9	10/cm <sup>2</sup>	Once	1
Wound Inflammation Treatment	No. 1 No. 3	9	40	Twice per week	3
Homeostasis of Oozing Hemorrhage	No. 3	9~15	20 / oozing hemorrhage	Once	1
Tooth Extraction Follow-up	No. 4	9	30 / tooth	Twice	2

Treatment			extraction		
-----------	--	--	------------	--	--

For those highly allergic patients, if an injection is not to be administered, it is necessary to tightly attach the probe at close proximity to the treatment body portions. It has proved that it is effective to use the accessory foot pedal switch to start operating the equipment.

## 6. MAINTENANCE

1. Follow the “Safety Instructions” and “Safety and Health Standards” for cleaning and sterilizing the glass probe.
2. Only original accessories made by the original manufacturer should be used, including probes and plug-connected parts..
3. Probes have major safe functionalities. Consequently, non-packaged accessories or other probes not supplied by manufacturers shall not be used for this unit.
4. Once using it, the unit should be cleaned every time, and the probe is required to be disinfected by disinfectant after every therapy.
5. A wipe sprayed with disinfectant can be used to wipe the unit.
6. Probes shall not be soaked into solutions for disinfection or sterilization.

**NOTE: Steam sterilization is not covered by warranty, because this sterilization process will shorten the service life of equipment during sterilization.**

7. Prevent the glass from being broken during handling the glass probe.
8. Change the probe once every twelve months, depending on the frequency of usage as the power of the glass probe will be reduced with time. However, no repairs are required for probes.
9. Technical safety supervision should be conducted once every two years in accordance with the Medical Device Directive of the European Community.
10. **For any defects found, please don't disassemble and don't use the unit**, because this may cause injury to the patients when the equipment does not conform to the required safety regulations and this would cause warranty invalid.
11. Environmental Conditions:
  - Storage temperature : -10□ / +50□
  - Operating temperature : +15□ / +45□

## 7. TROUBLE SHOOTING

FAULT	POSSIBLE CAUSE	SOLUTION
Display is not working.	Electric power is not connected properly.	Re-connect properly the electric power and re-start.
”OUTPUT LOCK” shows on the display.	1.The air is very humid. 2.The Safety Rod is too close to the ozone generating handpiece.	1.Disconnect the Safety Rod or decrease the setting of power. 2. Re-start the unit.
Output power is not strong enough.	The probe is damaged or broken.	Replace with a new probe.

## 8. SPECIFICATION and ACCESSORIES

### SPECIFICATION

#### 1》 Control Box

Input	:	DC24V 500mA
Output	:	500Hz, 2~59 $\mu$ s
Max. Output Current	:	$I_{max} \leq 100\mu A$
Safety Output Lock Current	:	$>100Ma$ (Duration: $t \geq 0.1s$ )

#### 2》 Switching Power Adapter

Input	:	AC100V~AC240V, 50/60Hz, 1.2A
Output	:	DC24V 1.5A

#### 3》 Probes

Neon filled glass probe	
Hi isolation handle	
Ozone generation electronically	
Boost voltage	: 1000~4000AC (16 level adjustable)

### STANDARD ACCESSORIES

Control Box	x	1
Ozone Generating Handpiece	x	1
Safety Rod (Ground Wire)	x	1
Foot Pedal Switch	x	1
Switching Power Adapter	x	1
Probes	x	4

## 9. WARRANTY

- 1》 This instrument described in this manual has been fully inspected and conforms to the current product specification.
- 2》 This product is guaranteed for the defects occurred during all the normal operations of this equipment.
- 3》 Non-normal operations include glass fractures, wire ruptures, and external damages, or the use of unqualified accessories.
- 4》 This unit is warranted for its designated use, against original defects in materials and workmanship for **period of 12 months** from date of purchase, **whereas the period of warranty of the probes is 6 months.**
- 5》 To prevent delay in processing a claim under the warranty, the registration card should be completed and returned at the time of purchase.
- 6》 All warranty terms are subject / based upon the warranty card enclosed in each unit.