



MM-AE Series Inverter/Chargers



Owner's Manual

Disclaimer of Liability

The use of this manual and the conditions or methods of installation, operation, use, and maintenance of the MM-AE Series Inverter/Charger are beyond the control of Magnum Energy, Inc. Therefore, this company assumes no responsibility and expressly disclaims any liability for loss, damage, or expense whether direct, indirect, consequential, or incidental that may arise out of or be in any way connected with such installation, operation, use, or maintenance.

Due to continuous improvements and product updates, the images shown in this manual may not exactly match the unit purchased.

Restrictions on Use

The MM-AE Series Inverter/Charger may only be used in life-support devices or systems with the express written approval of Magnum Energy. Failure of the MM-AE Series Inverter/Charger can reasonably be expected to cause the failure of that life-support device or system, or to affect the safety or effectiveness of that device or system. If the MM-AE Series Inverter/Charger fails, it is reasonable to assume that the health of the user or other persons may be endangered.

Contact Information

Magnum Energy, Inc.
2211 West Casino Rd.
Everett, WA 98204
Phone: (425) 353-8833 / Fax: (425) 353-8390
Web: www.magnumenergy.com

Record the unit's model and serial number in case you need to provide this information in the future. It is much easier to record this information now, instead of trying to gather it after the unit has been installed.	
Model:	Serial Number:
<input type="checkbox"/> MM612AE	Q1
<input type="checkbox"/> MM1512AE	AG
<input type="checkbox"/> MM1524AE	S1

Conventions Used in this Manual

Terminology

AC source or External AC power - refers to Alternating Current (AC) provided by the utility electric power grid or from a generator.

AE application - typically refers to using the inverter in a system that uses Alternative Energy (e.g., solar, wind, or hydro). This term is also used to refer to inverters used in a home, office, or cabin installation.

Safety symbols

To reduce the risk of electrical shock, fire, or other safety hazard, the following safety symbols have been placed throughout this manual to indicate dangerous and important safety instructions.



WARNING: This symbol indicates that failure to take a specified action could result in physical harm to the user.



CAUTION: This symbol indicates that failure to take a specified action could result in damage to the equipment.



Info: This symbol indicates information that emphasizes or supplements important points of the main text.

IMPORTANT PRODUCT SAFETY INSTRUCTIONS

This manual contains important safety instructions that must be followed during the installation and operation of this product. Read all instructions and safety information contained in this manual before installing or using this product.

- All electrical work must be performed in accordance with local, state, and federal electrical codes.
- This product is designed for indoor/compartment installation. DO NOT expose to rain, snow, moisture, or liquids of any type.
- Use insulated tools to reduce the chance of electrical shock or accidental short circuits.
- Remove all jewelry such as rings, watches, bracelets, etc., when installing or performing maintenance on the inverter.
- Always disconnect the batteries or energy source prior to installing or performing maintenance on the inverter. Live power may be present at more than one point since an inverter utilizes both batteries and AC. Turning off the inverter may not reduce this risk. As long as AC power is connected, it will pass through the inverter regardless of the ON/OFF power switch setting.
- Always verify proper wiring prior to starting the inverter.
- Do not operate the inverter if it has been damaged.
- Do not dismantle the inverter; there are no user-serviceable parts contained in this product. Attempting to service the unit yourself could cause electrical shock. Internal capacitors remain charged after all power is disconnected.
- No AC or DC disconnects are provided as an integral part of this inverter. Both AC and DC disconnects must be provided as part of the system installation.

- No overcurrent protection for the battery supply is provided as an integral part of this inverter. Overcurrent protection of the battery cables must be provided as part of the installation.
- No overcurrent protection for the AC output wiring is provided as an integral part of this inverter. Overcurrent protection of the AC output wiring must be provided as part of the installation.

IMPORTANT BATTERY SAFETY INSTRUCTIONS

- Wear eye protection (safety glasses) when working with batteries.
- Remove all jewelry such as rings, watches, bracelets, etc., when installing or performing maintenance on the inverter.
- Never work alone. Always have someone near you when working around batteries.
- Use proper lifting techniques when working with batteries.
- Never use old or untested batteries. Check each battery's label for age, type, and date code to ensure all batteries are identical.
- Batteries are sensitive to changes in temperature. Always install batteries in a stable environment.
- Install batteries in a well ventilated area. Batteries can produce explosive gasses. For compartment or enclosure installations, always vent batteries to the outside.
- Provide at least one inch of air space between batteries to provide optimum cooling.
- Never smoke when in the vicinity of batteries.
- To prevent a spark at the battery and reduce the chance of explosion, always connect the cables to the batteries first. Then connect the cables to the inverter.
- Use insulated tools at all times.
- Always verify proper polarity and voltage before connecting the batteries to the inverter.
- To reduce the chance of fire or explosion, do not short-circuit the batteries.
- In the event of accidental exposure to battery acid, wash thoroughly with soap and water. In the event of exposure to the eyes, flood them for at least 15 minutes with running water and seek immediate medical attention.
- Recycle old batteries.

SAVE ALL INSTRUCTIONS

Table of Contents

1.0 Introduction	1
MM-AE Series Models	1
How an Inverter/Charger Works	2
Appliances that will run from a Modified Sine Inverter	2
Appliances and Run Time.....	2
Standard Features and Benefits	3
Battery Temperature Sensor	5
2.0 Installation	6
Pre-Installation	6
Unpacking and Inspection.....	6
Locating and Mounting the Inverter.....	8
Wiring Guidelines	10
DC Wiring.....	11
DC Wire Sizing and Overcurrent Protection	11
DC Overcurrent Protection.....	13
DC Grounding.....	13
DC Cable Connections.....	14
Battery Bank Wiring	15
Inverter to Battery Bank Wiring	15
DC Ground Wire.....	16
DC Negative Wire.....	16
Battery Temperature Sensor	16
DC Positive Wire	16
AC Wiring	17
Neutral to Safety Ground Bonding	17
AC Wiring Connections.....	18
AC Wire Size and Overcurrent Protection	18
AC Input Wiring	19
AC Output Wiring.....	20
Ground-Fault Circuit Interruption Breakers	21
Functional Test.....	21
3.0 Operation	23
Operating Modes	23
Inverter Mode.....	23
Standby Mode	24
Protection Circuitry Operation	28
Inverter Start-up.....	29
ON/OFF Switch	29
Status LED Indicator	29
Factory Default Settings	30
4.0 Maintenance and Troubleshooting	32
Recommended Inverter and Battery Care	32
Resetting the Inverter.....	32

Table of Contents

5.0 Specifications	34
Appendix A - Optional Equipment and Accessories	35
Appendix B - Battery Information	36
Battery Bank Sizing	36
Battery Types	36
Battery Configuration.....	36
Series Wiring.....	36
Parallel Wiring	37
Series-Parallel Wiring.....	37
Appendix C - Warranty/Service Information	40
How to Receive Repair Service	41

List of Figures

Figure 1, MM-AE Series Inverter/Charger	1
Figure 2, Top Side Features.....	3
Figure 3, Front and Back Side Features.....	4
Figure 4, Left Side Features	5
Figure 5, Battery Temperature Sensor (BTS)	5
Figure 6, Basic Installation Diagram	7
Figure 7, Approved Mounting Orientations.....	9
Figure 8, MM-AE Series Inverter/Charger Dimensions	10
Figure 9, DC Cable to Battery Terminals.....	14
Figure 10, DC Cable to Inverter's DC Terminals.....	14
Figure 11, AC Wiring Connections	20
Figure 12, Automatic 4-Stage Charging Graph	26
Figure 13, BTS Temperature to Charge Voltage Change.....	27
Figure 14, Series Battery Wiring	36
Figure 15, Parallel Battery Wiring.....	37
Figure 16, Series-Parallel Battery Wiring	37
Figure 17, Battery Bank Wiring Examples (12-volt)	38
Figure 18, Battery Bank Wiring Examples (24-volt)	39

List of Tables

Table 1, Recommended DC Wire/Overcurrent Device	12
Table 2, DC Wire Size For Increased Distance	13
Table 3, Wire Color to AC Wire Connection	18
Table 4, Minimum Wire Size to Circuit-breaker Size	19
Table 5, Inverter Battery Turn On/Off Levels.....	29
Table 6, Inverter/Charger Default Settings	31
Table 7, Troubleshooting Guide.....	33
Table 8, MM-AE Series Specifications	34

1.0 Introduction

Congratulations on your purchase of an MM-AE Series inverter/charger from Magnum Energy, Inc. This product is designed especially for your back-up power or standalone application. Powerful, yet simple to use, the Magnum Energy inverter will provide you with years of trouble-free use.

Please read this chapter to familiarize yourself with the features and benefits of your particular MM-AE Series model.



Figure 1, MM-AE Series Inverter/Charger

MM-AE Series Models

MM612AE - a 600 watt inverter/charger with 7 amp AC transfer capability and 30 amp/12 VDC, 4-stage PFC charger. The AC input and output are provided with pigtail wires to allow hardwiring to a main AC distribution panel and to an inverter sub-panel. Includes a 15' battery temperature sensor.

MM1512AE - a 1500 watt inverter/charger with 12 amp AC transfer capability and 70 amp/12 VDC, 4-stage PFC charger. The AC input and output are provided with pigtail wires to allow hardwiring to a main AC distribution panel and to an inverter sub-panel. Includes a 15' battery temperature sensor.

MM1524AE - a 1500 watt inverter/charger with 12 amp AC transfer capability and 35 amp/24 VDC, 4-stage PFC charger. The AC input and output are provided with pigtail wires to allow hardwiring to a main AC distribution panel and to an inverter sub-panel. Includes a 15' battery temperature sensor.



Info: These units have common input/output neutrals for uses in AE applications (i.e., homes/cabins/offices). If your installation is for a mobile application (RV, truck, or boat), the appropriate model for these applications is the MM or MMS Series inverter.

How an Inverter/Charger Works

An inverter takes direct current (DC) from your batteries and turns it into alternating current (AC), like you use at home. With MM-AE Series models, it also takes alternating current (when connected to a generator or to utility power) and transforms it into direct current to recharge your batteries.

The two modes of operation associated with this inverter/charger are referred to in this document as:

Inverter Mode: DC from the batteries is transformed into modified sine wave AC for powering your AE applications.

Standby Mode: The unit operates as a battery charger to convert incoming AC power into DC power to recharge the batteries while continuing to pass the incoming AC power directly to the inverter's output to power any AC loads.

Appliances that will run from a Modified Sine Inverter

Today's inverters come in two basic output waveforms: modified sine (actually a modified square wave) and pure sine wave. Modified sine wave inverters approximate a pure sine waveform.

The output of a modified sine wave inverter will run most electronic and household items including but not limited to TV, VCR, satellite dish receiver, computers, and printers. Some devices such as rechargeable power supplies for phones, drills, and other like devices may not run or be damaged by modified sine wave inverters.

Appliances and Run Time

The MM-AE Series inverter/charger can power a wide range of household appliances. As with any appliance using batteries for power, there is a certain length of time that it can run – this is called "run time". Actual run time depends on several variables including the size and the type of appliance, the type of batteries installed in your application, as well as the battery's capacity and age. Other factors such as the battery's state of charge and temperature can also affect the length of time your appliances can run.

Depending on your inverter capacity, larger electrical appliances such as coffee pots and hair dryers can be used for short durations. However, loads that are used for longer periods such as stoves or water heaters can quickly drain your batteries and are not recommended for inverter applications.

All electrical appliances are rated by the amount of power they consume. The rating is printed on the product's nameplate label, usually located on its chassis near the AC power cord. Even though it is difficult to calculate exactly how long an inverter will run a particular appliance, the best advice is trial and error. Your MM-AE Series inverter/charger has a built-in safeguard that automatically protects your batteries from being over-discharged.

Standard Features and Benefits

The MM-AE Series inverter/charger converts 12 or 24 volts (depending on model) direct current (VDC) power from your battery to 120 volts alternating current (VAC) power. The multi-stage battery charger optimizes incoming AC power using Power Factor Correction (PFC) technology to keep the inverter's battery bank fully charged. This inverter is designed to allow easy installation and use, and with its die-cast aluminum baseplate it ensures maximum durability and cooler more efficient operation.

The inverter/charger provides the following:

- 600 or 1500 watts continuous (depending on model) at 25°C.
- Numerous protection features to provide a safe and peace-of-mind operation.
- AC transfer switch circuitry; allowing incoming AC power to continue to pass-thru to power loads even if the inverter is off.
- Dead battery charging for batteries that are extremely low.
- Automatic 4-stage battery charger with power factor correction and temperature compensation – for optimum battery charging (using the temperature sensor).
- Modern and aesthetically pleasing design with large AC wiring compartment (provides easy access to AC wiring for simple and quick connections) and 360° DC connection terminals with color coded insulating covers.
- True RMS output voltage regulation to ensure the inverter will deliver the correct amount of power – within the DC input voltage range and the continuous output power level.
- Quick connection accessory and remote ports – easily accepts several optional remote controls and the Battery Temperature Sensor.

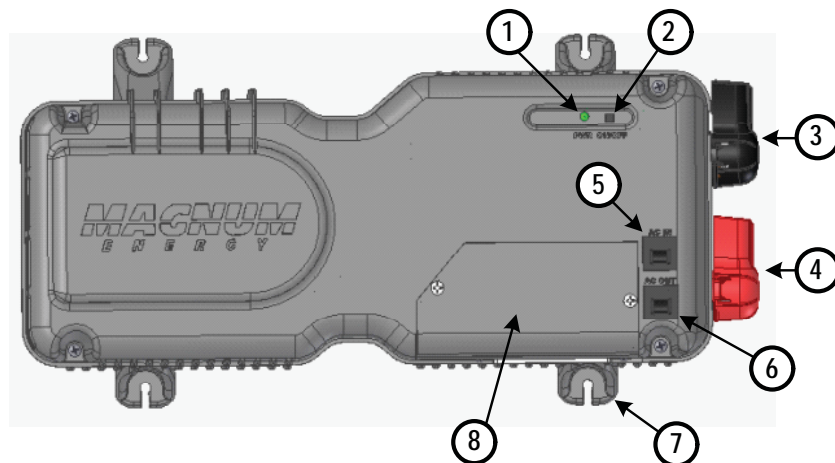

Figure 2, Top Side Features

1.0 Introduction

1. **Inverter Status Indicator** - this green LED illuminates to provide information on the inverter's operation.
2. **Power Switch** - momentary pushbutton switch that turns the inverter on or off.
3. **Negative DC Terminal (black)** - the inverter's connection to the negative terminal on the battery bank.
4. **Positive DC Terminal (red)** - the inverter's connection to the positive terminal on the battery bank.
5. **Input Circuit Breaker** - this circuit breaker protects the unit's internal wiring and pass-thru relay.
6. **Output Circuit Breaker** - this circuit breaker provides another layer of overload protection. This is not a branch-circuit rated breaker. Separate AC output breakers are required on the output.
7. **Mounting Flanges (x4)** - secures the inverter to shelf/wall.
8. **AC Wiring Compartment** - provides access for all AC input and output connections on the inverter.

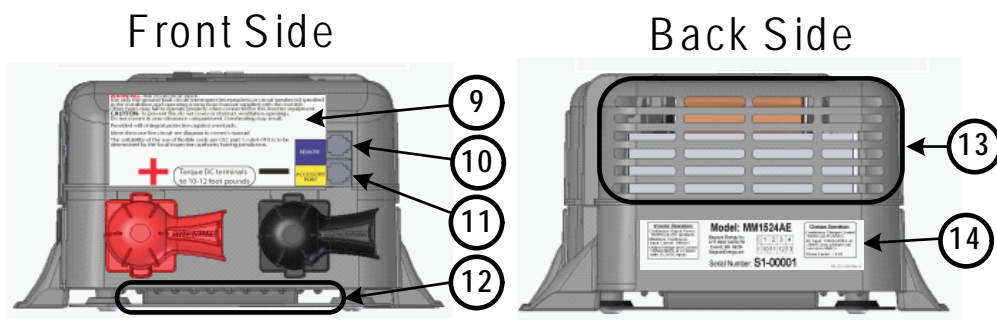

Figure 3, Front and Back Side Features

9. **Warning and Information Label** - provides pertinent information for safely using the inverter.
10. **REMOTE Port Connection** - a RJ11 connector that allows an optional remote control to be connected.
11. **ACCESSORY PORT Connection** - a RJ11 connector to allow the Battery Temperature Sensor (BTS) or MM-AE accessories (e.g., MM-DCLD) to be connected.
12. **Intake Vent** - ventilation openings to pull in air to help keep the inverter cool for peak performance.
13. **Exhaust Vent** - ventilation openings that allow heated air to be removed by the internal cooling fan.
14. **Model/Serial Number Label** - includes model/serial number and provides specifications and information on the inverter and charger. See the **MM-AE Series Specifications** on page 34 for more information and the different models available.

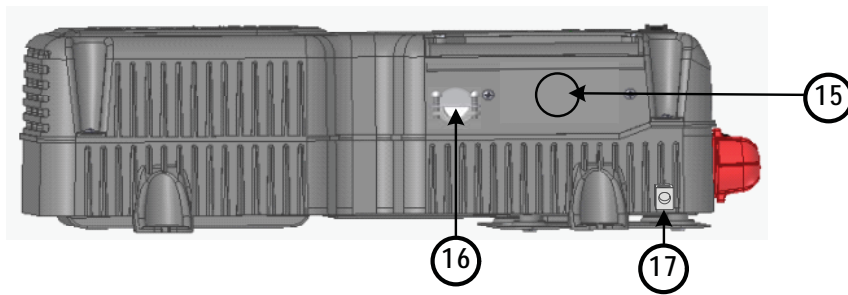

Figure 4, Left Side Features

15. AC Output Connection - AC knockout (output) for hardwiring.

16. AC Input Connection - AC knockout (input) for hardwiring.

17. DC Ground Terminal - this connection is used to tie the exposed chassis of the inverter to the DC grounding system. This terminal accepts CU/AL conductors from #14 AWG to #6 AWG.

Battery Temperature Sensor

A plug-in external Battery Temperature Sensor (BTS) is provided for units with the battery charger feature. When installed, the BTS automatically adjusts the battery charger's BULK, ABSORB, and FLOAT voltage set-points (based on temperature) for better charging performance and longer battery life. If the temperature sensor is NOT installed and the batteries are subjected to large temperature changes, battery life may be shortened.

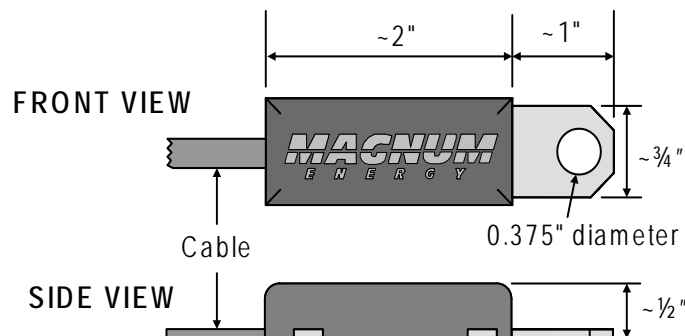

Figure 5, Battery Temperature Sensor (BTS)

2.0 Installation

Pre-Installation

Before installing the inverter, read the entire Installation section. The more thorough you plan in the beginning, the better your inverter needs will be met.



WARNING: Installations should be performed by qualified personnel, such as a licensed or certified electrician. It is the installer's responsibility to determine which safety codes apply, and to ensure that all applicable installation requirements are followed. Applicable installation codes vary depending on the specific location and the type of installation.



Info: Review the "Important Product Safety Information" on page ii and the "Important Battery Safety Instructions" on page iii before any installation.

The basic system diagram shown in Figure 6 should be reviewed to assist you in planning and designing your installation.

Unpacking and Inspection

Carefully remove the MM-AE Series inverter/charger from its shipping container and inspect all contents. Verify the following items are included:

- MM-AE Series inverter/charger
- Red and black DC terminal covers
- AC access cover with two screws
- Two 1/2" hex-head kee nuts (installed on the DC terminals)
- Battery Temperature Sensor (BTS)
- MM-AE Series Owner's Manual

If items appear to be missing or damaged, contact your authorized Magnum Energy dealer or Magnum Energy.

If at all possible, keep your shipping box. It will help protect your inverter from damage if it ever needs to be returned for service.

Save your proof-of-purchase as a record of your ownership; it will also be needed if the unit should require in-warranty service.

Record the unit's model and serial number in the front of this manual in case you need to provide this information in the future. It is much easier to record this information now, instead of trying to gather it after the unit has been installed.

MM-AE Series Inverter

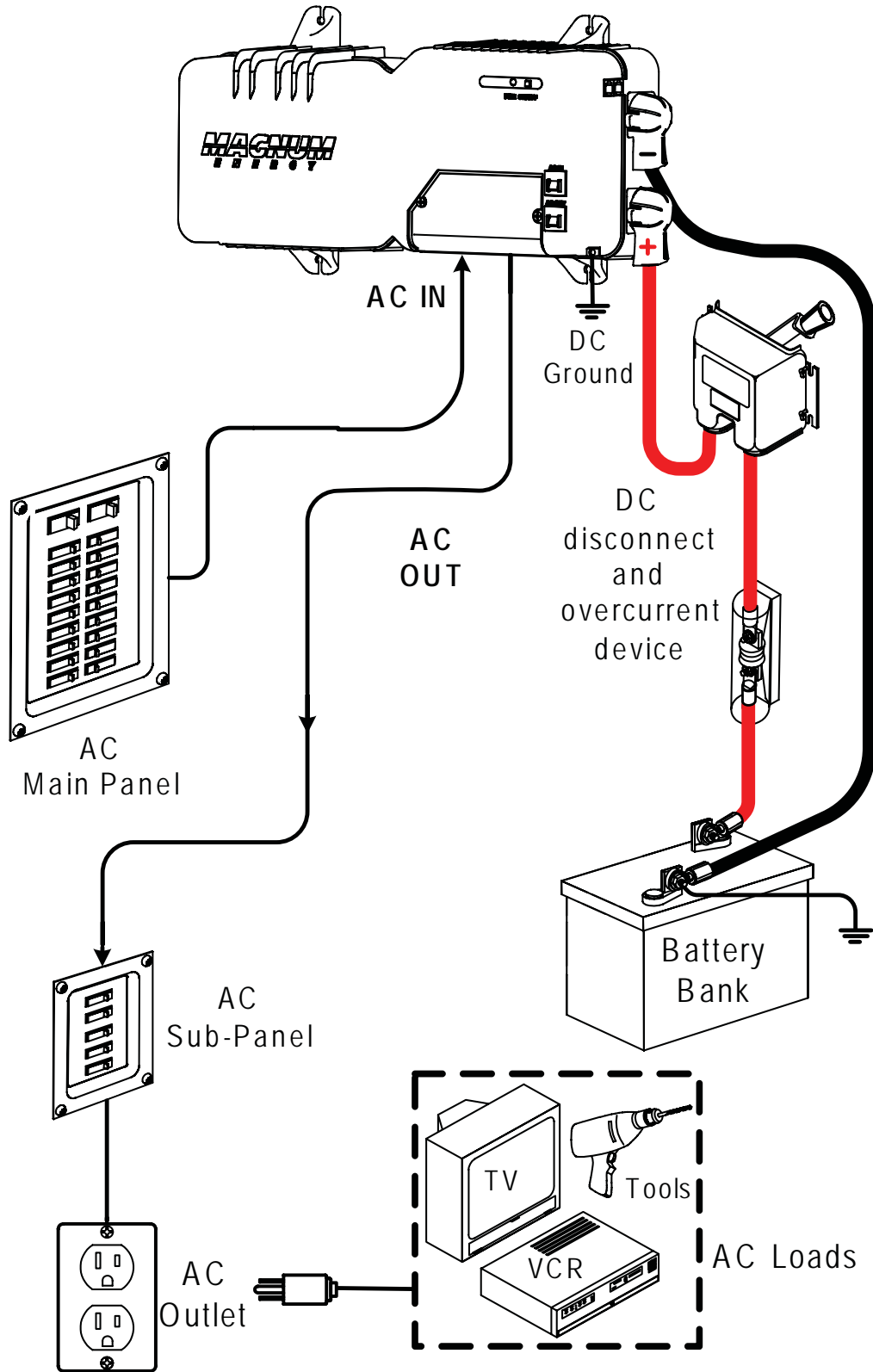

Figure 6, Basic Installation Diagram

Locating and Mounting the Inverter



WARNINGS:

- Do not mount the inverter near any flammable or combustible fluid or components.
- Provide adequate clearance/ventilation to the inverter.
- Mount only on a non-combustible surface.
- Maximum ambient temperature around the inverter must not exceed 77° F (25° C) to meet power specifications.

The inverter should only be installed in a location that meets the following requirements:

Clean and Dry - The inverter should not be installed in an area that allows dust, fumes, insects, or rodents to enter or block the inverter's ventilation openings. The area also must be free from any risk of condensation, water, or any other liquid that can enter or fall on the inverter. The inverter uses stainless steel fasteners, plated copper busbars, and a power-coated aluminum base. Also, the internal circuit boards are conformal coated. The above measures are undertaken to help fight the harmful effects of corrosive environments. However, the life of the inverter is uncertain if used in any of these types of environments, and inverter failure under these conditions is not covered under warranty.

Cool - The inverter should be protected from direct exposure to the sun or any equipment that produces extreme heat. The ambient air temperature should be between 32° F (0° C) and 104° F (40° C); keep in mind that the inverter's output specifications are rated at 77° F (25° C), so the cooler the better within this range.

Ventilated - In order for the inverter to provide full output power and avoid over-temperature fault conditions do not cover or block the inverter's ventilation openings, or install this inverter in an area with limited airflow. Allow as much clearance around the inverter's intake and exhaust ventilation openings as possible, see Items 12 and 13 in Figure 3. At the minimum, allow an airspace clearance of 6" (15 cm) at the front and back, and 3" (7.5 cm) everywhere else to provide adequate ventilation.

If installed in an enclosure, a fresh air intake opening must be provided directly to the front side (intake vent) and an exhaust opening on the back side (exhaust vent) of the inverter. This will allow cool air from the outside to flow into the inverter, and heated air to exit away from the inverter and the enclosure. When mounted in an enclosed compartment, airflow must be at least 59 cfm in order to maintain no more than a 68° F (20° C) rise in compartment temperature. Minimum clearances can be reduced if airflow is increased, but in no case should clearance around the inverter be less than 2" (5 cm) on all sides.

Safe - Keep any flammable/combustible material (e.g., paper, cloth, plastic, etc.) that may be ignited by heat, sparks, or flames at a minimum distance of 2 feet (60 cm) away from the inverter. Do not install this inverter in any area that contains extremely flammable liquids like gasoline or propane, or in locations that require ignition-protected devices.

Close to the battery bank - As with any inverter, it should be located as close to the batteries as possible. Long DC wires tend to lose efficiency and reduce the overall performance of an inverter. However, the unit should not be installed in the same compartment as the batteries or mounted where it will be exposed to gases produced by the batteries. These gases are corrosive and will damage the inverter. Also, if these gases are not ventilated and allowed to collect, they could ignite and cause an explosion.

Accessible - Do not block access to the inverter's remote control and accessory ports. Also, allow enough room to access the AC and DC wiring connections, as they will need to be checked and tightened periodically. See Figure 8 for the MM-AE Series' inverter dimensions.

Mounting Orientation - To meet regulatory requirements, the MM-AE Series inverter/charger can only be mounted on a horizontal surface (shelf or table) or a vertical surface (wall or bulkhead) either right-side up or upside-down, as shown in Figure 7. The inverter must be mounted on a non-combustible surface, and this surface and the mounting hardware must be capable of supporting at least twice the weight of the inverter. After determining your mounting position, use the base of the inverter's chassis as a template to mark your mounting screw locations. Remove the inverter and drill pilot holes into the mounting surface.

After the inverter has been properly mounted, proceed to the DC Wiring section.

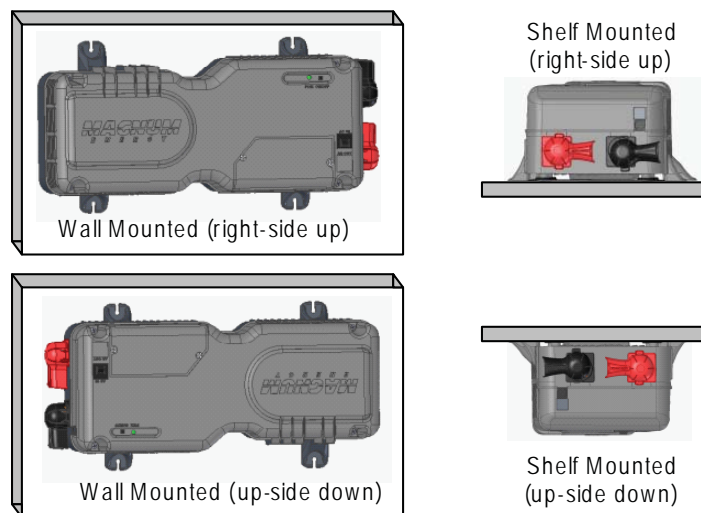

Figure 7, Approved Mounting Orientations

2.0 Installation

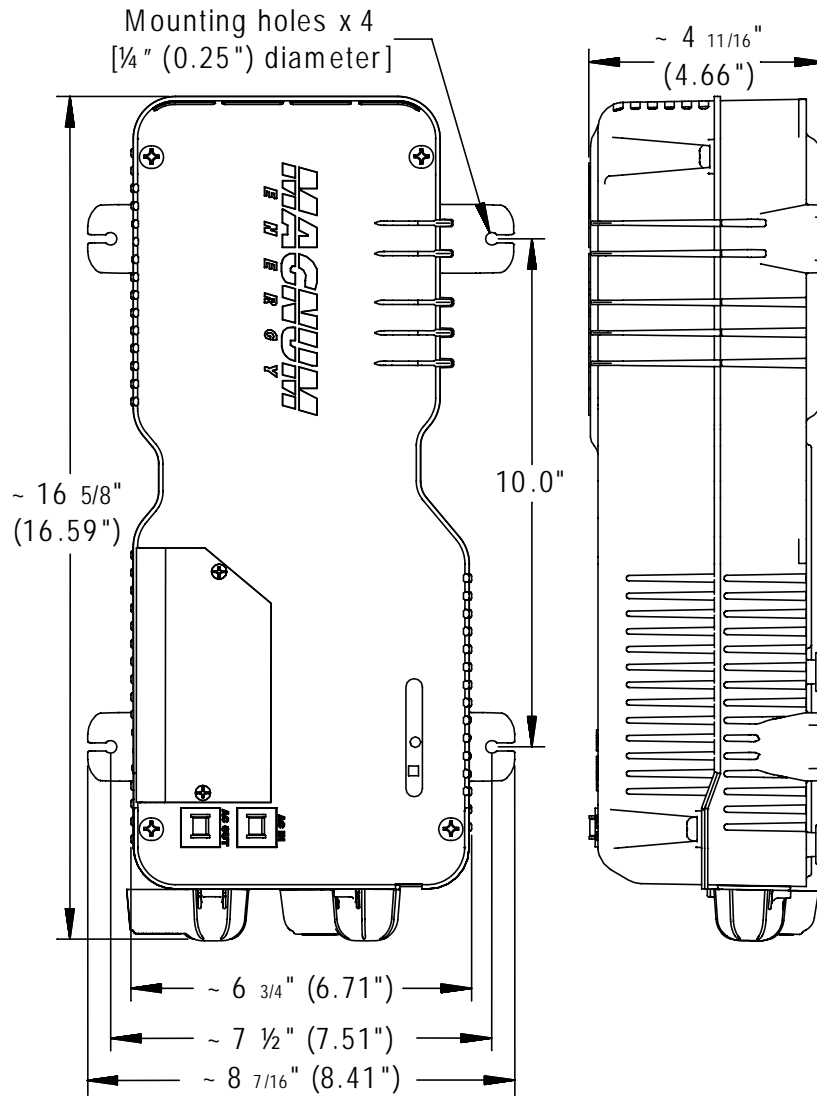

Figure 8, MM-AE Series Inverter/Charger Dimensions

Wiring Guidelines

- Before connecting any wires, determine all wire routes to and from the inverter throughout the home or cabin.
- Conductors passing through walls or other structural members must be protected to minimize insulation damage such as chafing, which can be caused by vibration or constant rubbing.
- Always check for existing electrical, plumbing, or other areas of potential damage prior to making cuts in structural surfaces or walls.
- Make sure all wires have a smooth bend radius and do not become kinked.
- Both AC and DC overcurrent protection must be provided as part of the installation.

- DC wires and cables should be tied together with wire ties or electrical tape approximately every 6 inches. This helps improve the surge capability and reduces the effects of inductance, which improves the inverter waveform and reduces wear on the inverter's filter capacitors.
- Use only copper wires with a minimum temperature rating of 75°C.
- To ensure the maximum performance from the inverter, all connections from the battery bank to the inverter should be minimized; the exceptions are the DC overcurrent disconnect in the positive line and a shunt in the negative line. Any other additional connection will contribute to additional voltage drops, and these extra connections points may loosen during use.
- All wiring to the battery terminals should be checked periodically (once a month) for proper tightness. The torque requirement for the DC terminals is between 10 to 12 foot-pounds. If you don't have a torque wrench, ensure all DC terminals are tight and cannot move.



CAUTION: Be aware that overtightening and misthreading the nuts on the DC terminals can cause the bolts to strip and snap/break off.

DC Wiring

This section describes the inverter's required DC wire sizes and the recommended disconnect/overcurrent protection, and how to make the DC connections to the inverter and the battery bank.

DC Wire Sizing and Overcurrent Protection

It is important to use the correct DC wire to achieve maximum efficiency from the system and reduce fire hazards associated with overheating. See Table 1 to select the minimum DC wire size needed based on your inverter model. If the distance from the inverter to the battery bank is greater than 3 feet, use Table 2 to help determine the minimum recommended cable sizes for longer distances. Always keep your wire runs as short as practical to help prevent low voltage shutdowns, and keep the DC breaker from nuisance tripping (or open fuses) because of increased current draw. Undersized cables can also lower the inverter's peak output voltage, as well as reduce its ability to surge heavy loads.



Info: The DC wires must be color coded with colored tape or heat shrink tubing; RED for positive (+), BLACK for negative (-), and GREEN for DC ground.

2.0 Installation

The DC wires must have soldered and crimped lugs, crimped copper compression lugs, or aluminum mechanical lugs. Soldered connections alone are not acceptable for this application.

Table 1, Recommended DC Wire/Overcurrent Device

	Inverter Model		
	MM612AE	MM1512AE	MM1524AE
Maximum Continuous Current ¹	80 amps	200 amps	100 amps
DC Grounding Electrode Wire Size ²	# 6 AWG	# 6 AWG	# 6 AWG
Minimum DC Wire Size ³ (90°C rating in free air)	# 2 AWG (190 amps)	# 1/0 AWG (260 amps)	# 1/0 AWG (260 amps)
Maximum DC Fuse Size ⁴	200 amps with time delay	300 amps with time delay	300 amps with time delay



Info: The term “in free air” is defined by the NEC as not encased in conduit or raceway.

If the inverter is expected to operate at a distance greater than three feet from the battery bank, the DC wire size will need to be increased to overcome the increase in resistance – which affects the performance of the inverter. Continue to use the overcurrent device and DC ground wire previously determined from Table 1 and then, refer to Table 2 to determine the minimum DC wire size you need for various distances based on your inverter model.

Note 1 - Maximum Continuous Current is based on the inverter’s continuous power rating at the lowest input voltage with an inefficiency factor.

Note 2 - Per the NEC, the DC grounding electrode conductor can be a #6 AWG conductor if that is the only connection to the grounding electrode and that grounding electrode is a pipe, rod, or plate electrode.

Note 3 - Wire size is based on the requirements needed to increase efficiency and reduce stress to the inverter.

Note 4 - The next larger standard size overcurrent device may be used if the de-rated cable ampacity falls between the standard overcurrent devices found in the NEC.

Table 2, DC Wire Size For Increased Distance

	Minimum recommended DC wire size (one way)			
	3 ft or less	3 to 5 ft	5 to 10 ft	10 to 15 ft
MM612AE	#2 AWG	#1 AWG	#1/0 AWG	#2/0 AWG
MM1512AE	# 1/0 AWG	#1/0 AWG	#2/0 AWG	#4/0 AWG
MM1524AE	# 1/0 AWG	#1/0 AWG	#2/0 AWG	#4/0 AWG

DC Overcurrent Protection

For safety and to comply with NEC (National Electrical Code) electrical code regulations, you must install a DC overcurrent protection device in the positive DC cable line to protect your DC cables. This DC overcurrent device can be a fuse or circuit-breaker, but must be DC rated. It must be correctly sized according to the size of DC cables being used, which means it is required to open before the cable reaches its maximum current carrying capability, thereby preventing a fire. See Table 1 to select the DC overcurrent device based on the minimum wire size for your inverter model.

If using a fuse, we recommend using a class-T type or equivalent. This fuse type is rated for DC operation, can handle the high short-circuit currents, and allows for momentary current surges from the inverter without opening.

DC Grounding

The inverter/charger should always be connected to a permanent, grounded wiring system. The idea is to connect the metallic chassis of the various enclosures together to have them at the same voltage potential, which reduces the possibility for electric shock. For the majority of installations, the inverter chassis and the negative battery conductor are connected to the system's ground bond via a safety-grounding conductor (bare wire or green insulated wire) at only one point in the system. Per the NEC, the size for the grounding conductor is usually based on the size of the overcurrent device used in the DC system. Refer to Table 1 to select the appropriate DC ground wire based on the overcurrent device used for your inverter model.

2.0 Installation

DC Cable Connections

When connecting the DC cable to the battery or to the inverter's DC terminals, the hardware should be installed in the correct order to prevent high resistance connections from heating up and possibly causing the connections to melt. Follow Figures 9 and 10 to stack the hardware correctly. Tighten the terminal connections from 10 to 12 foot-pounds.



CAUTION: Do not put anything between the DC cable ring lug and the battery terminal post or inverter's DC terminal. If antioxidant grease or spray is used, apply it after all the connections have been made and are properly tightened.



CAUTION: Overtightening or misthreading nuts on the DC terminals will cause the bolts to strip and snap/break-off.

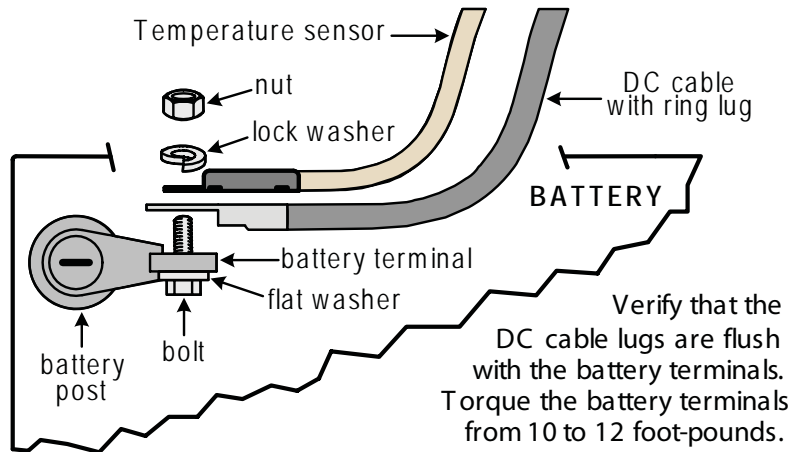

Figure 9, DC Cable to Battery Terminals



CAUTION: The inverter is NOT reverse polarity protected (negative and positive connected backwards). You must verify the correct voltage polarity **BEFORE** connecting the DC wires or damage may occur.

Crimped and sealed copper ring terminal lugs with a 5/16" hole should be used to connect the DC wires to the inverter's DC terminals.

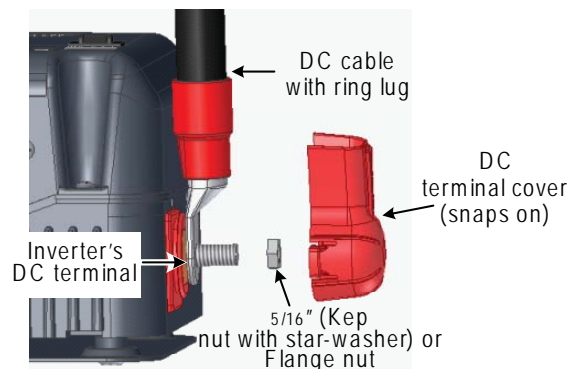

Figure 10, DC Cable to Inverter's DC Terminals

Battery Bank Wiring



WARNING: Lethal currents will be present if the positive and negative cables attached to the battery bank touch each other. During the installation and wiring process, ensure the cable ends are insulated or covered to prevent touching/shorting the cables.



Info: DO NOT connect the DC wires from the battery bank to the inverter until: 1) all DC/AC wiring is complete, 2) the correct DC and AC overcurrent protection have been installed, and 3) the correct DC voltage and polarity have been verified.



Info: For optimum performance, a minimum battery bank of 200 AHr is recommended.

Depending upon the type of batteries you use in the installation (6 or 12 VDC), the batteries must be wired in series, parallel, or series-parallel (see Appendix B - Battery Information, for guidance on wiring batteries together). The interconnecting DC wires must be sized and rated exactly the same as those that are used between the battery bank and the inverter.

Place the batteries as close as practical to the inverter, preferably in an insulated and ventilated enclosure. Allow adequate space above the batteries to access the terminals and vent caps (as applicable). Also, allow at least 1" of space between the batteries to provide good air flow. DO NOT mount the batteries directly under the inverter.



Info: To ensure the best performance from your inverter system do not use old or untested batteries. Batteries should be of the same size, type, rating, and age.



CAUTION: Install batteries in a well ventilated area. Batteries can produce explosive gasses. For compartment or enclosure installations, always vent batteries to the outside.

Inverter to Battery Bank Wiring



WARNING: Ensure all sources of DC power (i.e., batteries, solar, wind, or hydro) and AC power (utility power or AC generator) are de-energized (i.e., breakers opened, fuses removed) before proceeding.

2.0 Installation



CAUTION: The inverter is NOT reverse polarity protected. If this happens, the inverter will be damaged and will not be covered under warranty. Before connecting the DC wires from the batteries to the inverter, verify the correct battery voltage and polarity using a voltmeter. If the positive terminal of the battery is connected to the negative terminal of the inverter and vice versa, severe damage will result. If necessary, color code the cables with colored tape or heat shrink tubing; RED for positive (+), and BLACK for negative (-) to avoid polarity confusion.



Info: The DC overcurrent device (i.e., fuse or circuit breaker) must be placed in the positive (RED) DC cable line between the inverter's positive DC terminal and the battery's positive terminal (RED); as close to the battery as possible.

DC Ground Wire

Route an appropriately sized DC grounding wire (GREEN or bare wire) from the inverter's DC Ground Terminal (see Figure 4, Item 17) to a dedicated system ground. Recommended tightening torque is 45 in. lbs.

DC Negative Wire

Route an appropriately sized DC negative wire (BLACK) from the negative terminal of the first battery string to the inverter's negative terminal (see Figure 16 for reference).

Battery Temperature Sensor

Connect the RJ11 connector end of the BTS to the ACCESSORY PORT (see Figure 3, Item 11) on the inverter. Connect the other end of the BTS to the negative terminal of the first battery string (in same place as the negative DC wire above); refer to Figure 9 for the correct hardware placement.

DC Positive Wire

Mount the DC fuse block and disconnect (or circuit breaker assembly) as near as practical to the batteries, and then open the disconnect (or circuit breaker).



WARNING: DO NOT close the DC fuse/DC disconnect (or close the DC circuit breaker) to enable battery power to the inverter at this time. This will occur in the **Functional Test** after the installation is complete.

Route and connect an appropriately sized DC positive wire (RED) from the DC fuse block (or circuit breaker assembly) to the inverter's positive DC terminal.

Connect a short wire (same rating as the DC wires) to one end of the fuse block and the other end of the short wire to the positive terminal of the last battery string (see Figure 16). This is essential to ensure even charging and discharging across the entire battery bank.

Ensure the DC wire connections (to batteries, inverter, and fuse lugs/ DC circuit breaker) are flush on the surface of the DC terminals, and the hardware (lock washer and nut) used to hold these connections are stacked correctly (see Figures 9 and 10).

Verify all DC connections are torqued from 10 to 12 foot-pounds.

Once the DC connections are completely wired and tested, coat the terminals with an approved anti-oxidizing spray.

Press the red and black terminal covers onto the inverter's DC connectors to secure them in place.

If batteries are in an enclosure, perform a final check of the hold down brackets and all connections. Close and secure the battery enclosure.

AC Wiring

This section describes the required AC wire size and the overcurrent protection needed. It also provides information on how to make the AC connections.



WARNING: All wiring should be done by a qualified person or a licensed electrician following all local/NEC codes.

Neutral to Safety Ground Bonding

The NEC (National Electric Code) provides the standards for safely wiring AE (house, cabin, or office) installations in the United States. These wiring standards require the AC source (inverter, utility power, or a generator) to have the neutral conductor tied to ground. These standards also require that the AC neutral be connected to safety ground (often called a "bond") in only one place at any time. If more than one bond is established, currents can circulate between neutral and ground and cause ground-loop currents. These "ground-loops" can trip GFCIs and cause an electric shock hazard. In AE installations, the neutrals are connected together and are always connected to safety ground at the main AC panel – never at the inverter.



Info: For an AE application, you must use an MM-AE Series inverter/charger. Non "AE" versions are designed for use in mobile applications.

AC Wiring Connections

For all hardwired inverter models, the AC input and output wiring is performed in the AC wiring compartment. This compartment is located on the top panel (see Figure 2, Item 8). If installed, remove the two Phillips screws on the cover to access the AC wiring compartment and locate the inverter's AC wiring. There is a label located in the AC access compartment which gives information on which wires are used for the AC input and output. You can also refer to Table 3 to match the inverter's AC wires to the appropriate AC wire connection.

Table 3, Wire Color to AC Wire Connection

	Wire color (label)	Wire connection
AC IN	Black (HOT IN)	Hot In
	White (NEUT IN)	Neutral In
AC OUT	Red (HOT OUT)	Hot Out
	White with black stripe (NEUT OUT)	Neutral Out
AC Ground	Green (GROUND)	AC IN & AC OUT Ground

The AC wires inside the AC compartment are #16 AWG with a temperature rating of 105° C. All AC connections should be made using an approved connector for your application (e.g., split bolt, twist-on wire connectors, etc.). Ensure the wire connectors used are rated for the size and number of wires you are connecting.

After connecting the wires together, gently pull on the wires to ensure they are securely held together. In a proper connection, no bare wire should be exposed.



Info: Per UL certification, non-metallic sheathed cable (i.e., Romex™) or an SO flexible cord with listed strain reliefs are allowed to be used to connect to the inverter; conduit connections are not allowed.

After all AC wiring in the inverter is complete (and before reattaching the AC access cover), ensure all connections are correct and secure.

AC Wire Size and Overcurrent Protection

The AC input and output wiring must be sized per the NEC and local electrical safety code requirements to ensure the wire's ability to safely handle the inverter's maximum load current. After determining the proper AC wire sizes, the inverter's AC input (unless you are using a flexible cord) and output wires are required to be protected against overcurrent and have a means to disconnect the AC circuits.

Overcurrent protection must be provided by fuses or circuit-breakers, and must be properly sized and rated for the wire they are protecting and the appliances being powered.

An external disconnect device is required for both the AC input and AC output wiring. Most inverter's that are "hardwired" use a service/distribution panel wired to the inverter's input (main panel), and a dedicated panel between the inverter's output wiring and the AC loads (sub-panel). These systems use the circuit breakers provided in the panels as the overcurrent protection and the AC disconnect. If fuses are used, then separate AC disconnect switches will be needed.

Based on information from the NEC, Table 4 provides the minimum AC wire size and the suggested breaker size based on the inverter model. However, larger wire size may be required because of voltage drop. The AC wire sizes provided in this table assume using only copper wire and a temperature rating of 75° C or higher. A minimum of #14 AWG is required for all AC wiring.

Table 4, Minimum Wire Size to Circuit-breaker Size

Inverter Model	AC Input			AC Output		
	Input Breaker	Minimum Wire Size	Suggested Breaker Size	Output Breaker	Minimum Wire Size	Suggested Breaker Size
MM612AE	7 amps	#14 AWG	10 amps	8 amps	#14 AWG	10 amps
MM1512AE	20 amps	#12 AWG	20 amps	12 amps	#14 AWG	15 amps
MM1524AE	20 amps	#12 AWG	20 amps	12 amps	#14 AWG	15 amps

AC Input Wiring

Your inverter has an AC transfer feature that passes the AC input power to the inverter's output. Connection to the AC input is made by hardwiring from a distribution panel as described below:

1. Run an appropriately sized 2-conductor plus ground cable (from the AC distribution panel) through a strain relief on the AC IN opening. Refer to Table 4 for minimum wire size and overcurrent protection required for the AC input wiring.
2. Remove about two inches of the insulating jacket from the AC cable, and then separate the three wires and strip about 3/4" of insulation from each wire.
3. Using approved AC wire connectors, connect the incoming Hot In, Neutral In, and Ground wires to the MM-AE Series' AC wires colored black (HOT IN), white (NEU IN), and green (AC GROUND) respectively.
4. After making the AC input connections, secure the AC input cable by tightening the strain relief.

The AC input wiring in the inverter is complete. Review all AC wiring to ensure all connections are correct and secure.

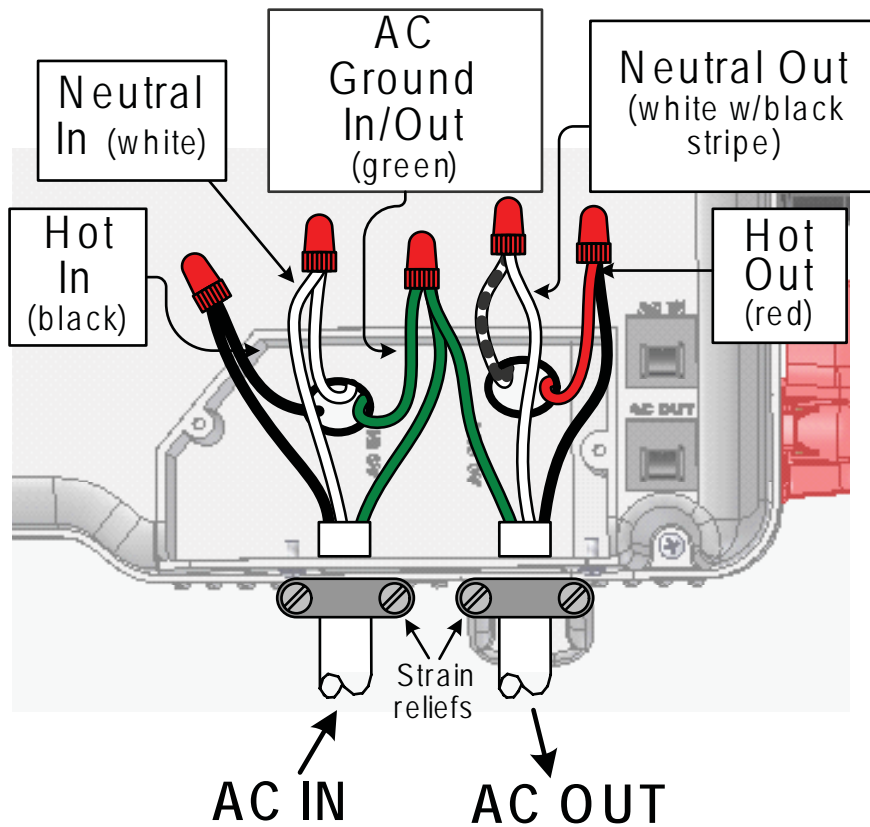

Figure 11, AC Wiring Connections

AC Output Wiring



CAUTION: The inverter's AC output must never be connected to an AC power source. This will cause severe damage to the inverter and is not covered under warranty.

When hardwiring the output of the inverter, a cable must be routed from the inverter's output to an AC distribution panel (sub-panel) that provides overcurrent protection to the loads powered by the inverter. Connect the AC output to this distribution panel as described below:

1. Remove the 1/2" knockout on the AC Output Connection (see Figure 4, Item 15) – use a utility knife to cut thru the round slot.
2. Discard this knockout and install a 1/2" strain relief in the AC OUT opening. You may need to file the opening edge for proper fit.
3. Run a 2-conductor plus ground cable through the strain relief in the AC OUT opening. Refer to Table 4 for the minimum wire size and the overcurrent protection required for the AC output wiring.

4. Remove about two inches of the insulating jacket from the AC cable, and then separate the three wires and strip about 3/4" of insulation from each wire.
5. Using approved AC wire connectors, connect the outgoing Hot Out, Neutral Out, and AC Ground wires to the MM-AE Series' AC wires colored red (HOT OUT), white with black stripe (NEU OUT), and green (AC GROUND) respectively. Gently pull on the wires to ensure they are securely held together, and check to see that no bare wire is exposed.
6. After making the AC output connections, secure the AC output cable by tightening the strain relief.
7. Connect the outgoing AC wires to an AC load panel equipped with overcurrent protection (e.g., circuit breakers).

The AC output wiring in the inverter should be complete. Before reattaching the AC access cover, review all AC wiring to ensure all connections are correct and secure.

Ground-Fault Circuit Interruption (GFCI) Breakers

Some electrical safety codes require GFCI's to be installed in AE applications (home/cabin/office). In compliance with UL standards, Magnum Energy has tested the following GFCIs and find that they function properly when connected to the inverter's AC output.

Shock Sentry™ #XGF15V-SP
Leviton Smart Lock #8899-A
Hubbel #GF520EMBKA



WARNING: Risk of electric shock. Use only the GFCIs [receptacles or circuit breaker(s)] specified in this manual. Other types may fail to operate properly when connected to this inverter.

Functional Test

After all electrical connections to the inverter, batteries, AC source, and loads (using a sub-panel) have been completed, follow these steps to test the installation and the inverter's operation.

1. Check the battery voltage and polarity before connecting the batteries to the inverter. Use a multimeter to verify 10 to 14 VDC (12-volt models) or 20 to 28 VDC (24-volt models) at the batteries' positive and negative terminals.
2. Apply battery power to the inverter by switching the DC disconnect ON (or close the DC circuit-breaker). The inverter will remain OFF, but the green status indicator on the front of the inverter will quickly blink once to indicate that DC power has been connected and is ready to be turned on.

2.0 Installation

3. Prior to turning on the inverter, make sure all connected loads (e.g., appliances) are switched OFF or disconnected from the AC outlets.

4. a. If a remote switch is connected, press the ON/OFF switch to turn the inverter on.

b. If there is not a remote switch connected, lightly press and release the inverter's ON/OFF power switch — located on the top of the inverter — to turn the inverter on.

Verify the inverter's status indicator is blinking – indicating the inverter is providing AC power.

5. Check the output voltage of the inverter by connecting a true RMS multimeter to the outlets powered by the inverter. Verify the voltage is 120 VAC +/- 5 VAC. If not using a true RMS meter the output AC voltage could indicate from 90 to 130 VAC, depending on the battery voltage.

6. Turn on or connect a load to the outlets and verify it comes on. Continue to keep the load connected and turned on.

7. Press the remote ON/OFF switch to turn the inverter off. If the remote is not used, press and release the inverter's ON/OFF power switch to turn the inverter off. The inverter's status indicator and the connected load should go off.

8. Apply AC power to the inverter's AC input. After the AC input power is qualified (approximately 15 seconds), the incoming AC power will transfer through the inverter to the inverter's AC output and power the connected load. Verify the inverter's status indicator and the connected load comes on.

9. Even though the connected load is on, the inverter is currently disabled/off. Press the remote's ON/OFF switch (or press and release the ON/OFF power switch on the inverter) to enable/turn on the inverter.

10. Disconnect the incoming AC power to the inverter. Verify the connected load remains on, but now is powered by the inverter.

If the inverter passes all the steps, the inverter is ready for use.

If the inverter fails any of the steps, refer to the Troubleshooting section.

3.0 Operation

Operating Modes

The MM-AE Series inverter/charger has two normal operating routines; Inverter Mode, which powers your loads using the batteries, and Standby Mode, which transfers the incoming AC power (i.e., utility power or a generator) to power your loads and also uses this incoming power to recharge the batteries. This inverter also includes an extensive protection circuitry that shuts down the inverter under certain fault conditions.

Inverter Mode

When the inverter is first powered up, it defaults to the OFF mode. The momentary ON/OFF power switch (Figure 2, Item 2) must be lightly pressed to turn the inverter ON. Subsequently pressing this switch alternately turns the inverter OFF and ON.

- **Inverter OFF** - When the inverter is OFF, no power is used from the batteries to power the AC loads and the status LED will be OFF. If AC power from an external source (utility or generator) is connected and qualified on the inverter's AC input, this AC input power will pass through the inverter to power the AC loads. However, if this AC power is lost, the AC loads will no longer be powered because the inverter is OFF.

When the inverter is turned ON, it operates either by "Searching" or "Inverting", depending on the connected AC loads.

- **Searching** - When the inverter is first turned ON, the automatic Search feature is enabled. This feature is provided to conserve battery power when AC power is not required. In this mode, the inverter pulses the AC output looking for an AC load (i.e., electrical appliance). Whenever an AC load (greater than 5 watts) is turned on, the inverter recognizes the need for power and automatically starts inverting. When there is no load (or less than 5 watts) detected, the inverter automatically goes back into search mode to minimize energy consumption from the battery bank. When the inverter is "Searching", the inverter's green LED flashes (fast).



Info: The factory default value for the Search feature is 5 watts, it can be turned off or adjusted from 5 to 50 watts using the ME-RC50 remote display.

- **Inverting** - When a load greater than 5 watts is connected to the inverter output, the MS Series "inverts" the DC power from the battery and supplies 120 VAC power to your sub-panel. The inverter's green LED flashes once every 2 seconds (medium flash) to indicate it is inverting. The amount of time the inverter can be inverting and providing power is directly related to the amount of AC loads that are connected and the capacity of the battery bank.

3.0 Operation

Standby Mode

The MM-AE Series features an automatic transfer relay and an internal battery charger when operating in the Standby Mode. The Standby Mode begins whenever AC power (utility or generator) is connected to the inverter's AC input. Once the AC voltage and frequency of the incoming AC power is within the AC input limits, an automatic AC transfer relay is activated. This transfer relay passes the incoming AC power through the inverter to power the AC loads on the inverter's output. This incoming power is also used to activate a powerful internal battery charger to keep the battery bank charged in case of a power failure.

Battery charging - The MM-AE Series models are equipped with an active Power Factor Corrected (PFC) multi-stage battery charger. The PFC feature is used to control the amount of power used to charge the batteries in order to obtain a power factor as close as possible to 1 (or unity). This causes the battery charger to look like a resistor to the line (forces the charge current waveshape to mirror the voltage waveshape). This feature maximizes the real power available from the AC power source (utility or generator), which translates into less power wasted and a greater charging capability than most chargers available today.

When an AC source (utility power or generator) is connected to an inverter that has a battery charger, the inverter monitors the AC input for acceptable voltage. Once the inverter has accepted the AC input, the AC transfer relay will close and charging will begin. Once charging, the DC voltage is monitored to determine the charging stage. If the DC voltage is low (≤ 12.9 VDC/12 volt models or ≤ 25.8 VDC/24 volt models), the charger begins bulk charging. If the DC voltage is high (> 12.9 VDC/12 volt models or > 25.8 VDC/24 volt models), the charger skips the initial Bulk/Absorb Charging stages and goes directly to float charging.

The multi-stage charger can use up to five different charging stages to help monitor and keep the batteries healthy. The five stages include an automatic 4-stage charging process (Bulk, Absorb, Float, and Full Charge), and a manual Equalization (EQ) charge stage. The automatic 4-stage charge process provides complete recharging and monitoring of the batteries without damage due to overcharging (see Figure 12). The Equalization stage (requires the ME-RC50 remote) is used to stir up stratified electrolyte and reverse any battery plate sulfation that might have occurred.

While charging, the unit may go into **Charger Back-off** protection which automatically reduces the charge current to the batteries.

This is caused by:

1. The internal temperature is too hot – the charger automatically reduces the charge rate to maintain temperature; or,

2. The AC input voltage falls < 85 VAC – the charger reduces the charge current to zero to help stabilize the incoming AC voltage; or
3. FET Temperature.

The automatic 4-stage charging process includes:

- **Bulk Charging:** This is the initial stage of charging. While bulk charging, the charger supplies the battery with constant current. The charger remains in bulk charge until the absorption charge voltage is achieved (14.6 VDC/12 volt models or 29.2 VDC/24 volt models)* – as determined by the Battery Type selection**.
- **Absorb Charging:** This is the second charging stage and begins after the bulk voltage has been reached. Absorb charging provides the batteries with a constant voltage and reduces the DC charging current in order to maintain the absorb voltage setting. The absorb charging time is 120 minutes – as determined by the Battery AmpHrs selection**.
- **Float Charging:** The third charging stage occurs at the end of the absorb charging time. While float charging (also known as a maintenance charge), the batteries are kept fully charged and ready if needed by the inverter. The Float Charging stage reduces battery gassing, minimizes watering requirements (for flooded batteries), and ensures the batteries are maintained at optimum capacity. In this stage, the charge voltage is reduced to the float charge voltage (13.4 VDC/12 volt models or 26.8 VDC/24 volt models)* — as determined by the Battery Type selection** — which can maintain the batteries indefinitely.
- **Full Charge (Battery Saver™ mode):** The fourth stage occurs after four hours of float charging. The Full Charge stage maintains the batteries without overcharging, preventing excessive loss of water in flooded batteries or drying out of GEL/AGM batteries. In this stage, the charger is turned off and begins monitoring the battery voltage. If the battery voltage drops low (≤ 12.7 VDC/12 volt models or ≤ 25.4 VDC/24 volt models), the charger will automatically initiate another four hours in float charge.

* These voltage settings are based on the Battery Temperature Sensor (BTS) being disconnected, or at a temperature of 77° F (25° C). If the BTS is installed, these voltage settings will increase if the temperature around the BTS is below 77° F (25° C), and decrease if the temperature around the BTS is higher than 77° F (25° C).

** The MM-AE Series uses changeable settings (see Table 6, Inverter Default Settings) that are adequate for most installations. However, if you determine that some of your operating parameters need to be changed, the ME-RC50 remote control can be purchased to allow changes to those settings.

3.0 Operation

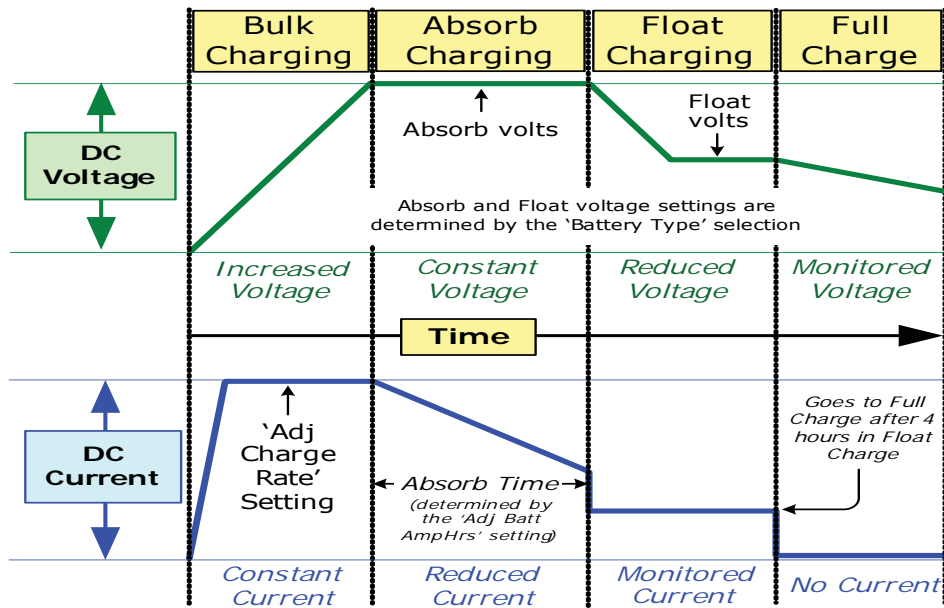

Figure 12, Automatic 4-Stage Charging Graph

Transfer time - While in Standby Mode, the AC input is continually monitored. Whenever AC power falls below the VAC dropout voltage (80 VAC, default setting), the inverter automatically transfers back to Inverter Mode with minimum interruption to your appliances – as long as the inverter is turned on. The transfer from Standby Mode to Inverter Mode averages approximately 16 milliseconds. While the MM-AE Series is not designed as a computer UPS system, this transfer time is usually fast enough to hold them up. However, the VAC dropout setting has an effect on the ability of the loads to transfer without resetting. The lower this setting, the longer the effective transfer will be and therefore, the higher the probability for the output loads to reset. This occurs because the incoming AC voltage is allowed to fall to a level that is so low that when the transfer does occur, the voltage on the inverter's output has already fallen to a low enough level to reset the loads.

The disadvantage of a higher VAC dropout setting is that smaller generators (or large generators with an unstable output) may nuisance transfer. This commonly happens when powering loads that are larger than the generator can handle – causing the generator's output voltage to constantly fall below the inverter's input VAC dropout threshold.



Info: You must use the ME-RC50 remote to adjust the VAC dropout setting – which in turn determines the VAC dropout threshold.



Info: When switching from Inverter Mode to Standby Mode, the inverter waits approximately 15 seconds to ensure the AC source is stable before transferring.

Battery Temperature Sensor Operation - The plug-in Battery Temperature Sensor (BTS) is used to determine the battery temperature around the batteries. This information allows the multi-stage battery charger to automatically adjust the battery charge voltages for optimum charging performance and longer battery life.

When the BTS is installed, if the temperature around the BTS is below 77°F (25°C) the absorb and float charge voltage increases. If the temperature around the BTS is higher than 77°F (25°C), the absorb and float charge voltage decreases. See Figure 13 to determine how much the charge voltage changes (increases or decreases) as the temperature reading of the BTS changes. For example, the nominal absorb charge voltage for a flooded battery at 77°F (25°C) on a 24-volt model is 29.2 VDC. If the battery temperature is 95°F (35°C), the absorb charge voltage would decrease to 28.6 VDC (29.2 VDC - 0.6 change).

If the temperature sensor is NOT installed, the charge voltages will not be compensated and the battery will maintain the charge it had at a temperature of 77°F (25°C). The life of the batteries may be reduced if they are subjected to large temperature changes when the BTS is not installed.



Info: When the BTS is connected, the battery charger uses a value of -5mV/°C/Cell from 0-50°C to change the charge voltage based on temperature.

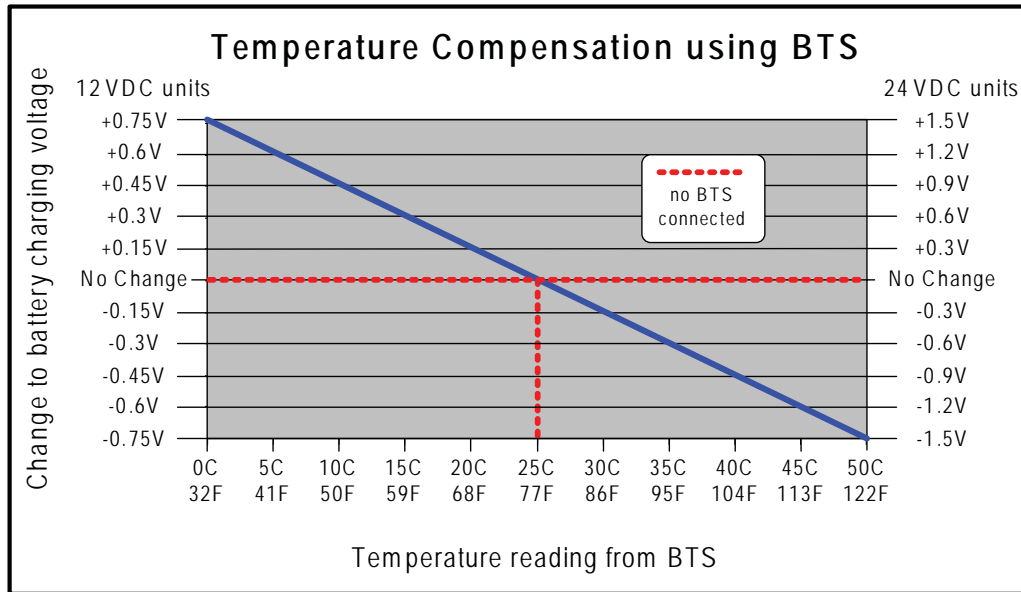

Figure 13, BTS Temperature to Charge Voltage Change

Protection Circuitry Operation

The inverter is protected against fault conditions, and in normal usage it will be rare to see any. However, if a condition occurs that is outside the inverter's normal operating parameters, then it will shut down and attempt to protect itself, the battery bank, and your AC loads. If there is a condition that causes the inverter to shut down, it may be one of the conditions listed below. Refer also to the Troubleshooting section to diagnose and clear the fault.

- **Low Battery** - The inverter will shut off whenever the battery voltage falls to the Low Battery Cut Out (**LBCO**) level to protect the batteries from being over-discharged. After the inverter has reached the LBCO level and turned off, the inverter will automatically restart after one of the following conditions:
 1. AC power is applied and the inverter begins operating as a battery charger.
 2. Battery voltage rises to the Low Battery Cut In (**LBCI**) level.

The inverter's status LED turns off when a low battery fault condition occurs. Refer to Table 5 to determine the LBCO and LBCI levels for your particular inverter model.

- **High Battery** - In the event the battery voltage approaches the High Battery Cut Out (**HBCO**) level, the inverter will automatically shut down to prevent the inverter from supplying unregulated AC output voltage. The inverter's status LED turns off when a high battery fault condition occurs. The inverter will automatically restart when the battery falls to the High Battery Cut In (**HBCI**) level. Refer to Table 5 to determine the HBCO and HBCI levels for your particular inverter model.



Info: When the BTS is connected, the battery charger uses a value of $-5\text{mV}/^{\circ}\text{C}/\text{Cell}$ from $0\text{-}50^{\circ}\text{C}$ to change the charge voltage based on temperature.

- **Overload** - During Inverter and Standby operation modes, the inverter monitors the DC and AC current levels. In the event of a short-circuit or an overload condition for more than a few seconds, the inverter will shut down. To start operating after this fault, the inverter would need to be restarted (turned back on) after the inverter's AC loads are reduced/removed.
- **Over-temperature** - If internal power components begin to exceed their safe operating temperature level, the inverter will shut down to protect itself from damage. The inverter's status LED turns OFF to indicate the over-temperature fault condition. The inverter will automatically restart after the units cools down.

- **Internal Fault** - The inverter continually monitors several internal components and the processor communications. If a condition occurs that doesn't allow proper internal operation, the inverter will shut down to protect itself and the connected loads. The inverter will need to be reset to start operating.

Table 5, Inverter Battery Turn On/Off Levels

Inverter Battery Turn On/Off Levels	Inverter Model		
	MM612AE	MM1512AE	MM1524AE
HBCO	>15.8 VDC	>15.8 VDC	>31.6 VDC
HBCI	15.5 VDC	15.5 VDC	31.0 VDC
LBCI	≥12.5 VDC	≥12.5 VDC	≥25.0 VDC
LBCO* (one minute delay)	10.0 VDC (9.0 - 12.2 VDC)	10.0 VDC (9.0 - 12.2 VDC)	20.0 VDC (18.0 - 24.4 VDC)
LBCO (immediate)	8.5 VDC	8.5 VDC	17.0 VDC

* - adjustable with remote

Inverter Startup

ON/OFF Switch - The inverter can be turned on and off by lightly pressing and releasing the Power ON/OFF switch on the front of the inverter. When the inverter is first connected to the batteries, or when its automatic protection circuit has turned the inverter off, the ON/OFF switch will need to be pressed to start the unit. Once the inverter has been turned on, pressing the Power ON/OFF switch alternately turns the inverter on and off.



WARNING: The Power ON/OFF control switch does not turn on or off the charger feature. If AC power (utility or generator) is connected and qualified on the AC input, this AC power will also be available on the AC output and is not controlled by the Power ON/OFF switch.

Status LED Indicator - The status indicator is a green LED (Light Emitting Diode) that provides information on the operational mode of the inverter. Watch this indicator for at least 10 seconds to determine the inverter's operational condition from the information below:

Inverter Mode

- **Off** - Indicates the inverter is off; there is no AC power from the inverter, utility, or generator at the inverter's output terminals.
- **Blinks On** (once every second) - The inverter is on and is using energy from the battery. The inverter is either providing full power to the loads connected to the inverter, or it's in Search Mode and ready to supply AC power to the connected loads.

3.0 Operation

Protection Mode

There are five fault conditions that will cause the inverter to shut down: Low Battery, High Battery, Over-temperature, AC Overload, and Internal faults. If your inverter has shut down, monitor the status indicator and count the number of blinks that occur every four seconds to determine the particular reason for the shutdown. Refer to the Troubleshooting section to help diagnose/clear the fault condition.

- Blinks on 1 time every four seconds - Low Battery fault.
- Blinks on 2 times every four seconds - High Battery fault.
- Blinks on 3 times every four seconds - Over-temperature fault.
- Blinks on 4 times every four seconds - AC Overload fault.
- Blinks on 5 times every four seconds - Internal fault.

Charge Mode

The green LED status indicator provides additional information:

- Blinks off every four seconds - The unit is charging the batteries connected to the inverter. The external AC power (utility power or generator) connected to the inverter's input is passing through the inverter and is powering the AC loads connected to the inverter's output.

Factory Default Settings

The MM-AE Series inverter/charger uses default settings that are adequate for most installations (see Table 6). However, you can adjust these parameters using Magnum's optional ME-RC50 remote. The settings once programmed are saved in non-volatile memory and are preserved until changed – even if DC power to the inverter is lost (the ME-RC50 must always be connected). The following information can help you determine if you need the ME-RC50 remote*.

01 Search Watts: This setting allows you to turn off the power-saving Search Mode circuitry and to adjust the power level at which the inverter will “wake up” and start inverting.

02 Low Battery Cut Out: This setting determines when the inverter will turn off based on low battery voltage. The inverter turns off automatically after the battery voltage has been below this setting for more than one minute. This protects the batteries from over-discharge and the AC loads from unregulated power (brown-outs).

* Visit www.magnumenergy.com for more information.

03 Battery AmpHrs: This setting allows you to input the battery bank size in amp hours. This provides information to the charger on how long to charge the batteries in the Absorb Charging stage.

04 Battery Type: This setting identifies the type of batteries being used in the system. This provides information to the charger to determine what voltage level to use to charge the batteries.

05 Charge Rate: This setting can be used to turn off the charger, limit the amount of current that the charger can use (leaving more current available to power loads); or, to ensure small battery banks are not overheated because of a charge rate that is too high.

06 VAC Dropout: Sets the minimum AC voltage that must be present on the AC input before the unit transfers from Standby Mode to Inverter Mode. This protects the AC loads from utility outages and brown-outs.

The ME-RC50 remote also provides the following features:

- allows you to enable an equalize charge for certain battery types
- displays the inverter/charger's operating status
- provides fault information for troubleshooting

Table 6, Inverter Default Settings

Function	Default Settings
Search Watts	5W
LowBatCutOut	10.0 VDC (MM1524AE - 20.0 VDC)
Battery AmpHrs	400 AmpHrs (Absorb Time = 120 minutes)
Battery Type	Flooded - Liquid Lead Acid (Bulk = 14.6 VDC, Float = 13.4 VDC) (MM1524AE - Bulk = 29.2 VDC, Float = 26.8 VDC)
Charge Rate	100%
VAC dropout	80VAC

4.0 Maintenance and Troubleshooting

Recommended Inverter and Battery Care

The MM-AE Series inverter/charger is designed to provide you with years of trouble-free service. Even though there are no user-serviceable parts, it is recommended that every 6 months you perform the following maintenance steps to ensure optimum performance and extend the life of your batteries.



WARNING: Prior to performing these checks, switch both the AC and DC circuits OFF.

- Visually inspect the batteries for cracks, leaks, or swelling – replace if necessary.
- Use baking soda to clean and remove any electrolyte spills or buildups.
- Check and tighten all battery holddown clamps.
- Clean and tighten (10 to 12 foot-pounds) all DC terminals (battery and inverter) and connecting cables.
- Check and fill battery water levels (Liquid Lead Acid batteries only).
- Check individual battery voltages (replace those that vary more than 0.3 VDC of each other).
- Check all cable runs for signs of chafing – replace if necessary.
- Check the inverter's cooling vents – clean as necessary.

Resetting the Inverter

Under some fault conditions (i.e., an internal fault), the inverter will need to be reset.

To reset the inverter:

1. Press and hold the Power ON/OFF pushbutton for approximately 15 seconds, or until the status LED comes on and flashes rapidly (see Figure 2, Items 1 and 2).
2. Release the Power ON/OFF pushbutton once the rapid flashing has begun. The status LED will go off.
3. Press the Power ON/OFF pushbutton again to turn the inverter on.



Info: The Power ON/OFF pushbutton is a small *momentary* type switch which operates by lightly pressing and releasing.

Troubleshooting

The MM-AE Series inverter/charger is a fairly simple device to troubleshoot. There are only two active circuits (AC and DC), as well as a charging circuit. The following chart is designed to help you quickly pinpoint the most common inverter and charger faults.

Table 7, Troubleshooting Guide

Symptom	Possible cause	Recommended Solution
Low Battery Voltage (the status indicator blinks on 1 time every 4 secs)	The battery voltage level has dropped below the Low Battery Cut Out (LBCO) set-point for more than one minute (10.0VDC = LBCO default setting).	Battery voltage is too low. Check fuses/circuit-breakers and cable connections. Check battery voltage at the inverter's terminals. Your batteries may need to be charged, this fault condition will automatically clear when the battery voltage exceeds 12.5VDC.
High Battery Voltage (the status indicator blinks on 2 times every 4 secs)	The battery voltage is above 15.5 VDC. The inverter automatically resets and resumes operation when the battery voltage drops below 15.5 VDC.	This condition usually occurs only when an additional charging source (alternator, solar panels or other external charging sources) is used to charge the battery bank. Reduce or turn off any other charger to the inverter batteries to allow the voltage level to drop.
Over-temperature condition (the status indicator blinks on 3 times every 4 secs)	The internal temperature of the inverter has risen above acceptable limits; caused by loads too great for the inverter to operate continuously, or by lack of ventilation to the inverter. When the unit has cooled, it will automatically reset and resume operation.	Reduce the number of electrical loads that you are operating, this will avoid a repeat Over-temp shutdown if the cause was too many loads for the ambient
		Check ventilation around the inverter, ensure cool air is available to pass-thru the inverter.
AC Overload (the status indicator blinks on 4 times every 4 secs)	The inverter has turned off because the connected loads are larger than the inverter's output capacity or the output wires are shorted.	Reduce the AC loads connected to the inverter or remove all AC output wiring and restart the inverter.
Internal fault (the status indicator blinks on 5 times every 4 secs)	This fault occurs when an internal fault is detected.	To clear this fault, an inverter reset is required. Remove DC power to the inverter or press and hold down the power switch on the inverter for 15 seconds (until the green Status LED comes on). If this fault does not clear, the unit will need to be serviced.
Inverter's status light is off.	Inverter is switched OFF or there is no DC voltage (battery) connected to inverter.	Switch the inverter ON. Connect a battery with correct voltage to the inverter.
AC input won't connect (AC IN on remote blinks)	The incoming AC voltage will not be accepted if it is below the VAC Dropout setting (80VAC = VAC Dropout default setting).	Check the incoming AC voltage to the input of the inverter, ensure it is present and above the VAC dropout level.
Appliances turn off and on; or there is low AC output power.	Loose AC output connections.	Tighten AC output connections.
	Loose / corroded battery cables.	Clean and tighten all cables.
Inverter AC output voltage is too low or too high when using an AC voltmeter.	Wrong type of voltmeter used (will display 90 VAC to 130 VAC depending on the battery voltage).	Most meters are made to read Average AC voltage. The AC output of the MM is a "modified" waveform which requires using a "true" RMS voltmeter to correctly read the output voltage.
While charging, the DC charge voltage is higher or lower than expected.	If the Battery Temperature Sensor is installed, it will increase or decrease the DC voltage level depending on temperature around the battery sensor.	This is normal.

5.0 Specifications

5.0 Specifications

Table 8, MM-AE Series Specifications

MODEL	MM612AE	MM1512AE	MM1524AE
Inverter Specifications			
Input battery voltage range	9 to 16 VDC	9 to 16 VDC	18 to 32 VDC
Nominal AC output voltage	120 VAC +/- 5%		
Output frequency and accuracy	60 Hz +/- 0.1 Hz		
1msec surge current (amps AC)	27	42	45
100msec surge current (amps AC)	11	23	24
5 sec surge power (real watts)	1100	2100	2650
10 sec surge power (real watts)	1050	1900	2575
30 sec surge power (real watts)	1000	1750	2500
5 min surge power (real watts)	950	1550	2350
30 min surge power (real watts)	675	1525	1900
Continuous power output at 25° C	600 VA	1500 VA	1500 VA
Maximum input battery current	80 ADC	200 ADC	100 ADC
Inverter efficiency (peak)	95%	95%	91%
Transfer time	16 msec		
AC transfer capability	7A	12A	12A
Search mode (typical)	3 watts	6 watts	4 watts
No load (120 VAC output, typical)	10 watts	18 watts	9 watts
Waveform	Modified Sine Wave		
Charger Specifications			
Continuous output at 25° C	30 ADC	70 ADC	35 ADC
Charger efficiency	85%	88%	88%
Power factor	> 0.95		
Input current at rated output (amps AC)	4	9	9
Battery temperature compensation	Yes, 15 ft Battery Temp Sensor standard		
General Features and Capabilities			
Protection circuitry	Low/High Battery, Over-temp & Overload		
Corrosion protection	PCB's conformal coated, powder coated chassis		
Output circuit breaker	7A switchable	12A switchable	12A switchable
Input circuit breaker	8 AAC	20 AAC	20 AAC
Internal cooling	Yes, 0 to 59 cfm variable speed		
Optional remotes available	MM-RC or ME-RC50		
UL listing	NA		
Environmental Specifications			
Operating temperature	-20° C to +60° C (-4° F to 140° F)		
Non-operating temperature	-40° C to +70° C (-40° F to 158° F)		
Operating humidity	0 to 95% RH non-condensing		
Physical Specifications			
Dimensions (L x W x H)	16.6"x 8.4"x 4.7" (42cm x 21cm x 12cm)		
Mounting	Shelf or wall (no vents facing downward or upward)		
Weight	16 lbs. (7.3 kg)	22 lbs. (10 kg)	22 lbs. (10 kg)
Shipping weight	18 lbs. (8.2 kg)	24 lbs. (10.9 kg)	24 lbs. (10.9 kg)

Specifications @ 25° C - Subject to change without notice

Appendix - Optional Equipment and Accessories

The following Magnum Energy components are available for use with the MM-AE Series inverter/charger. Some of these items are required depending upon the intended use of the inverter.

Smart Battery Combiner

The Smart Battery Combiner (ME-SBC™) is designed to monitor and charge a second battery using a portion of the current that is charging the main battery. The ME-SBC eliminates a significant voltage drop, and provides automatic turn-on and turn-off based on adjustable voltage set-points. This allows different batteries to be charged from a single charging source, and prevents overcharging/undercharging.

Basic Remote Control

The ME-RC50 Remote Control Panel is simple to use; an LCD screen and "at a glance" LEDs display complete inverter/charger status. Soft keys provide simple access to menus and a rotary encoder knob allows you to scroll through and select a wide range of settings.

Auto Generator Start Controller

The ME-AGS-N Automatic Generator Start controller (Network version) is designed to automatically start your generator based on low battery condition or high temperature. The AGS controller includes an input voltage jumper (for 12, 24, and 48 volt battery banks) and a 4-position DIP (Dual In-line Package) switch which provides the ability to change the relay timing configurations to allow compatibility with a wider range of generators.

Battery Monitor Kit

The ME-BMK Battery Monitor Kit is a single battery bank amp-hour meter that monitors the condition of the battery and provides information to let you know how much energy you have available and let you plan your electrical usage to ensure the battery is not being over-discharged. The ME-BMK-NS version does not include a DC shunt – order the ME-BMK to receive a 500A/50mv DC shunt.

Fuse Block/Fuses

The Magnum Fuse/Fuse-blocks are used to protect the battery bank, inverter, and cables from damage caused by DC short circuits and overloads. They include a slow-blow fuse with mounting block and protective cover. The 125 and 200 amp models use an ANL type fuse and the 300 and 400 amp models use a Class-T fuse.

DC Load Disconnect

The MM-DCLD (DC Load Disconnect) pigtail adapter is designed to provide a means to DISABLE the inverter function when a 12 volt DC signal is removed.

Ignition Switch Activate

The MM-ISA is a pigtail adapter designed to automatically ENABLE the inverter function when a 12 volt DC signal is supplied.

Appendix B - Battery Information

Battery Bank Sizing

The size of the battery bank determines how long the inverter can power the AC loads without recharging. The larger the battery bank, the longer the run time. Size your battery bank to the system's AC load requirements and the length of time required to run the load from the batteries. In general, the battery bank should not be discharged more than 50%.

Battery Types

Batteries are available in different sizes, amp-hour ratings, voltage, and chemistries; they also come in liquid or gel, vented or non-vented, etc. They are also available for starting applications (such as an automobile starting battery) and deep discharge applications. Only the deep cycle types are recommended for inverter applications. Choose the batteries best suited for the inverter installation and cost. Use only the same battery type for all batteries in the bank. For best performance, all batteries should be from the same lot and date. This information is usually printed on a label located on the battery.

Battery Configuration

The battery bank must be wired to match the inverter's DC input voltage specifications. In addition, the batteries can be wired to provide additional run time. The various wiring configurations are:

Series Wiring

Wiring batteries in a series increases the total battery bank output voltage. A series connection combines each battery in a string until the voltage matches the inverter's DC requirement. Even though there are multiple batteries, the capacity remains the same. In the example below (Figure 14), two 6 VDC/200 AHr batteries are combined into a single string – resulting in a 12 VDC/200 AHr bank.

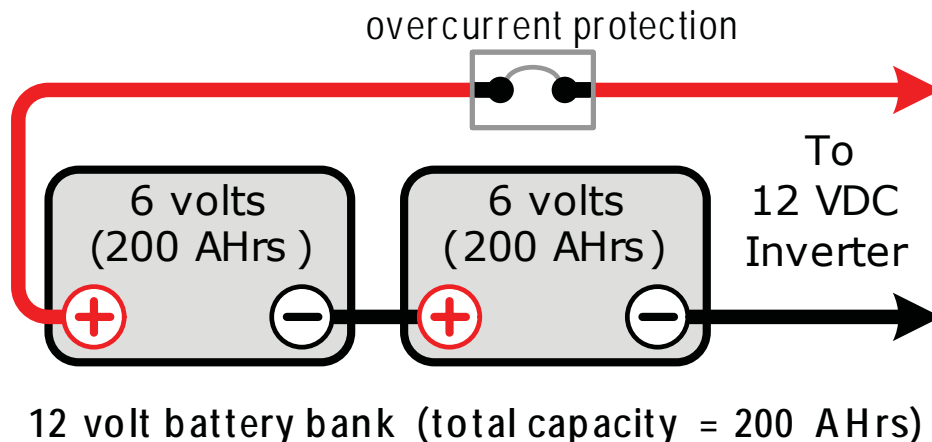

Figure 14, Series Battery Wiring

Parallel Wiring

Wiring the batteries in parallel increases the total run time the batteries can operate the AC loads. A parallel connection combines overall battery capacity by the number of batteries in the string. Even though there are multiple batteries, the voltage remains the same. In the example below (Figure 15), four 12 VDC/100 Ahr batteries are combined into a single 12 VDC/400 Ahr battery bank.

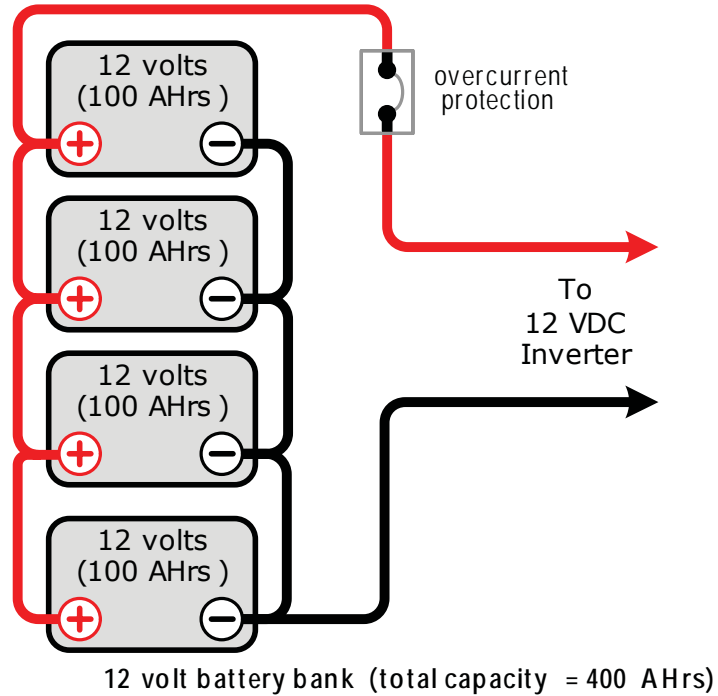

Figure 15, Parallel Battery Wiring

Series-Parallel Wiring

A series-parallel configuration increases both voltage (to match the inverter's DC requirements) and capacity (to increase run time for operating the loads) using smaller, lower-voltage batteries. In the example below (Figure 16), four 6 VDC/200 Ahr batteries are combined into two strings resulting in a 12 VDC/400 Ahr battery bank.

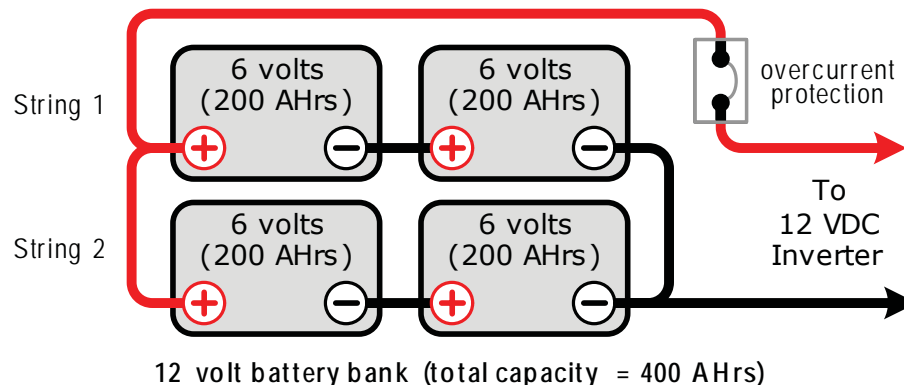

Figure 16, Series-Parallel Battery Wiring

Appendix B - Battery Information

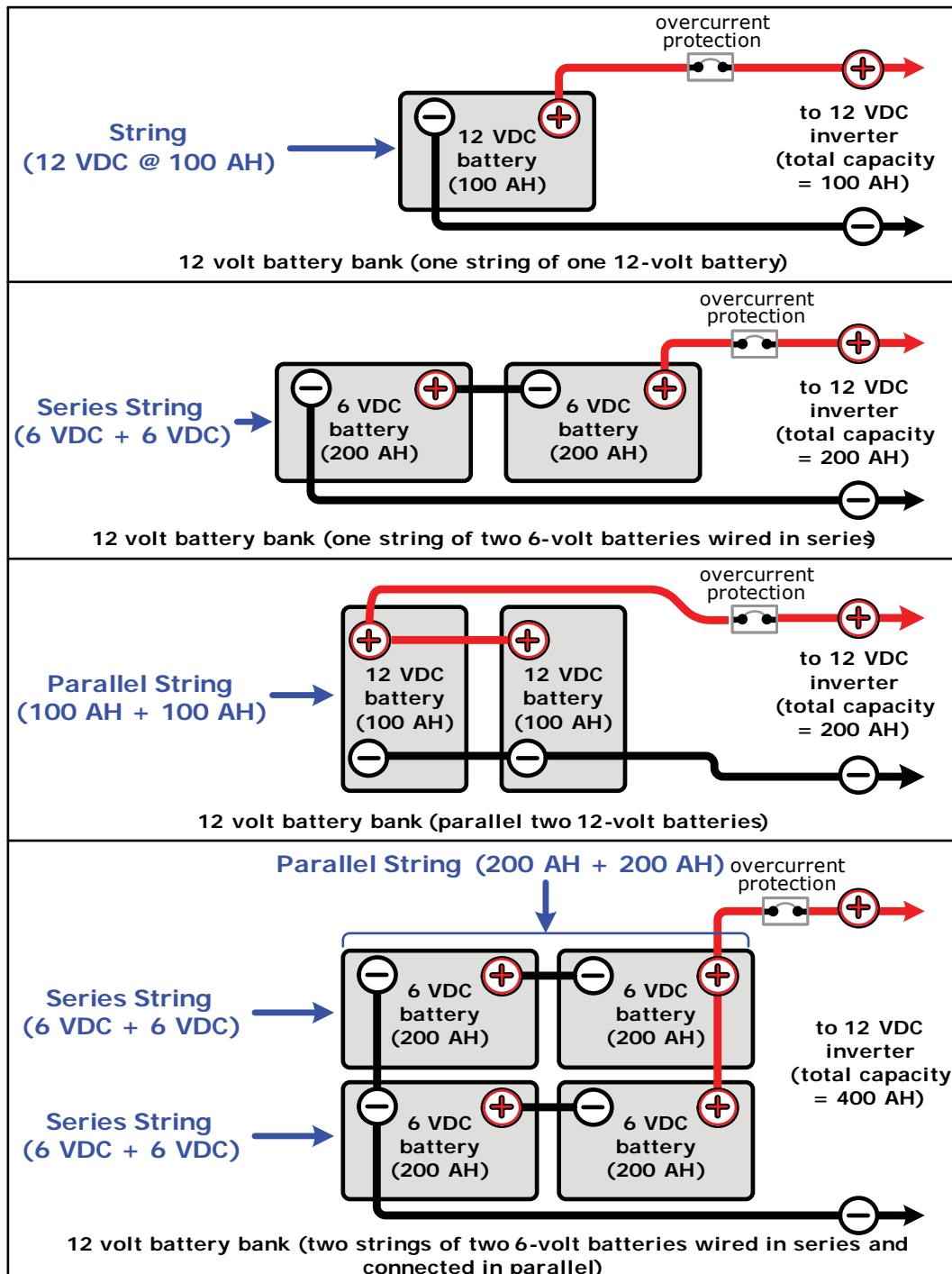

Figure 17, Battery Bank Wiring Examples (12 volt)

Appendix B - Battery Information

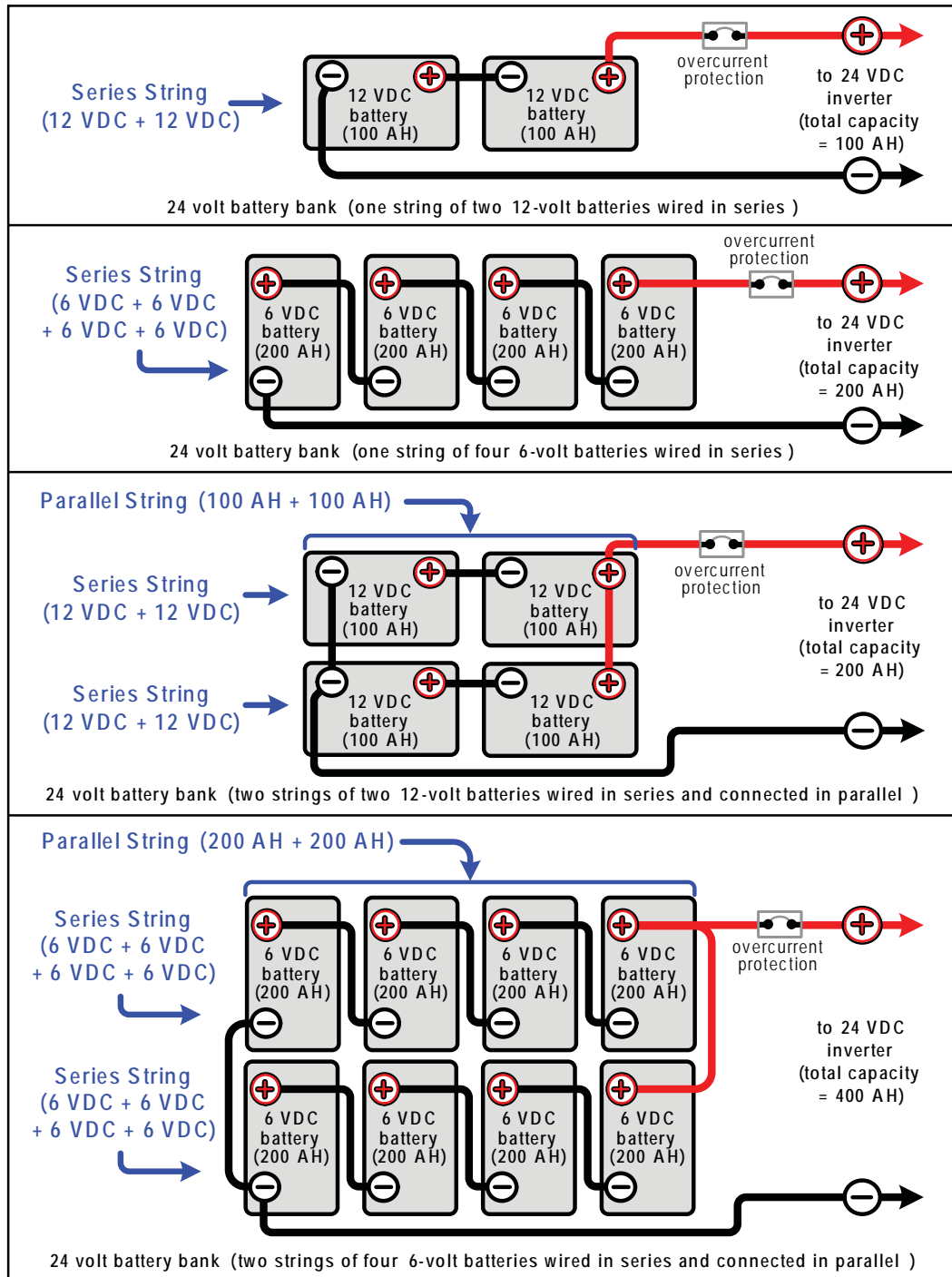

Figure 18, Battery Bank Wiring Examples (24-volt)

Appendix C - Warranty/Service Information

24 Month Limited Warranty

Magnum Energy, Inc., warrants this MM-AE Series Inverter/Charger to be free from defects in material and workmanship that result in product failure during normal usage, according to the following terms and conditions:

1. The limited warranty for the product extends for 24 months beginning from the product's original date of purchase.
2. The limited warranty extends to the original purchaser of the product and is not assignable or transferable to any subsequent purchaser.
3. During the limited warranty period, Magnum Energy will repair or replace (with factory new or rebuilt replacement items) at Magnum Energy's option any defective parts, or any parts that will not properly operate for their intended use – if such repair or replacement is needed because of product malfunction or failure during normal usage. The limited warranty does not cover defects in appearance (cosmetic or decorative), or any structural or non-operative parts. Magnum Energy's limit of liability under the limited warranty shall be the actual cash value of the product at the time the original purchaser returns the product for repair, determined by the price paid by the original purchaser. Magnum Energy shall not be liable for any other losses or damages.
4. Upon request from Magnum Energy, the original purchaser must prove the product's original date of purchase by a dated bill of sale, itemized receipt.
5. The original purchaser shall return the product prepaid to Magnum Energy in Everett, WA. After the completion of service under this limited warranty, Magnum Energy will return the product prepaid to the original purchaser via a Magnum selected non-expedited surface freight within the contiguous United States and Canada; this excludes Alaska and Hawaii.
6. If Magnum repairs or replaces a product, its warranty continues for the remaining portion of the original warranty period or 90 days from the date of the return shipment to the original purchaser, whichever is greater. All replaced products and parts removed from repaired products become the property of Magnum Energy.
7. This limited warranty is voided if:
 - the product has been modified without authorization
 - the serial number has been altered or removed
 - the product has been damaged through abuse, neglect accident, high voltage, or corrosion
 - the product was not installed and operated according to the owner's manual

BEFORE RETURNING ANY UNIT, CONTACT MAGNUM ENERGY FOR A RETURN MATERIAL AUTHORIZATION (RMA) NUMBER.

How to Receive Repair Service

If your product requires warranty service or repair, contact either:

1. An Authorized Service Center as listed on the Magnum Energy website at www.magnumenergy.com/servicecenters.htm; or
2. Magnum Energy, Inc. at:
Telephone: 425-353-8833
Fax: 425-353-8390
Email: warranty@magnumenergy.com

If returning the product directly to Magnum Energy for repair, you must:

- return the unit in the original, or equivalent, shipping container
- receive a Return Materials Authorization (RMA) number from the factory prior to the return of the product to Magnum Energy for repair
- place RMA numbers clearly on the shipping container or on the packing slip.

When sending your Product for service, please ensure it is properly packaged. Damage due to inadequate packaging is not covered under warranty. We recommend sending the Product by traceable or insured service.

MAGNUM

E N E R G Y

 **Soligent** YOUR U.S. DISTRIBUTOR
SOLIGENT
800-967-6917
www.soligent.net

Magnum Energy, Inc.
2211 West Casino Rd.
Everett, WA 98204
Phone: (425) 353-8833
Fax: (425) 353-8390
Web: www.magnumenergy.com