

Serial No.	H-A009-E-8
------------	------------

# Butterfly Valves Pneumatic Actuated Type TW

Type 75 **Nominal Size: 450-600mm (18"-24")**  
**Body Material: PP, PVDF**

Type 75D **Nominal Size: 450-600mm (18"-24")**  
**Body Material: PDCPD**

**User's Manual**

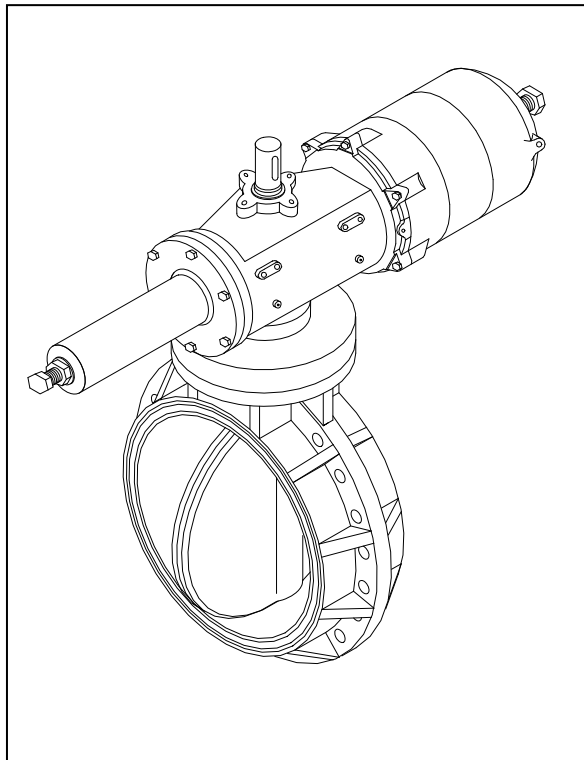



## Contents



- (1) Be sure to read the following warranty clauses of our product ..... 1
- (2) General operating instructions ..... 2
- (3) General instructions for transportation, unpacking and storage ..... 3
- (4) Name of parts ..... 4
- (5) Working pressure vs. temperature ..... 5
- (6) Specifications of actuator ..... 6
- (7) Specifications of solenoid valve ..... 6
- (8) Specifications of limit switch ..... 7
- (9) Specifications of pressure reducing valve with filter ..... 7
- (10) Specifications of speed controller ..... 8
- (11) Installation procedure ..... 8
- (12) Support setting procedure ..... 11
- (13) Air piping procedure ..... 12
- (14) Connection of limit switch procedure ..... 14
- (15) Connection of solenoid valve procedure ..... 15
- (16) Operating procedure ..... 16
  - Manual operating procedure ..... 16
  - Automatic operating procedure ..... 17
  - Adjustment of opening / closing speed procedure ..... 18
- (17) Disassembling method for replacing parts ..... 19
- (18) Stopper adjustment procedure ..... 20
- (19) Inspection items ..... 21
- (20) Troubleshooting ..... 21
- (21) Handling of residual and waste materials ..... 22

This user's guide contains information important to the proper installation, maintenance and safe use of an ASAHl AV Product. Please store this manual in an easily accessible location.

<Warning & Caution Signs>

 Warning	This symbol reminds the user to take caution due to the potential for serious injury or death.
 Caution	This symbol reminds the user to take caution due to the potential for damage to the valve if used in such a manner.

<Prohibited & Mandatory Action Signs>

	Prohibited: When operating the valve, this symbol indicates an action that should not be taken.
	Mandatory action: When operating the valve, this symbol indicates mandatory actions that must be adhered to.

**(1) Be sure to read the following warranty clauses of our product**

- Always observe the specifications of and the precautions and instructions on using our product.
- We always strive to improve product quality and reliability, but cannot guarantee perfection. Therefore, should you intend to use this product with any equipment or machinery that may pose the risk of serious or even fatal injury, or property damage, ensure an appropriate safety design or take other measures with sufficient consideration given to possible problems. We shall assume no responsibility for any inconvenience stemming from any action on your part without our written consent in the form of specifications or other documented approval.
- The related technical documents, operation manuals, and other documentation prescribe precautions on selecting, constructing, installing, operating, maintaining, and servicing our products. For details, consult with our nearest distributor or agent.
- Our product warranty extends for one and a half years after the product is shipped from our factory or one year after the product is installed, whichever comes first. Any product abnormality that occurs during the warranty period or which is reported to us will be investigated immediately to identify its cause. Should our product be deemed defective, we shall assume the responsibility to repair or replace it free of charge.
- Any repair or replacement needed after the warranty period ends shall be charged to the customer.
- The warranty does not cover the following cases:
  - (1) Using our product under any condition not covered by our defined scope of warranty.
  - (2) Failure to observe our defined precautions or instructions regarding the construction, installation, handling, maintenance, or servicing of our product.
  - (3) Any inconvenience caused by any product other than ours.
  - (4) Remodeling or otherwise modifying our product by anyone other than us.
  - (5) Using any part of our product for anything other than the intended use of the product.
  - (6) Any abnormality that occurs due to a natural disaster, accident, or other incident not stemming from something inside our product.

## (2) General operating instructions



Warning



- Do not disassemble or modify the actuator.  
(If disassembled forcible, internal parts may jump out and this is very dangerous.)



- Using a positive-pressure gas with our plastic piping may pose a dangerous condition due to the repellent force particular to compressible fluids even when the gas is under similar pressures used for liquids. Therefore, be sure to take the necessary safety precautions such as covering the piping with protective material. For inquiries, please contact us. For conducting a leak test on newly installed piping, be sure to check for leaks under water pressure. If absolutely necessary to use a gas in testing, please consult your nearest service station beforehand.



Caution



- Do not step on or apply excessive weight on valve. (It can be damaged.)
- Do not use AV valves in a place where they may become submerged in water.
- Do not use the valve in conditions where the fluid may have crystallized.

(The valve will not operate properly.)



- Keep the valve away from excessive heat or fire. (It can be damaged, or destroyed.)
- Always operate the valve within the pressure vs. temperature range.  
(The valve can be damaged or deformed by operating beyond the allowable range.)
- Allow sufficient space for maintenance and inspection.
- Select a valve material that is compatible with the media. For chemical resistance information, refer to “CHEMICAL RESISTANCE ON ASAHI AV VALVE”.  
(Some chemicals may damage incompatible valve materials.)
- Keep the valve out of direct sunlight, water and dust. Use cover to shield the valve.  
(The valve will not operate properly.)
- Perform periodic maintenance. (Leakage may develop due to temperature changes or periods of prolonged storage, rest, or operation.)
- Set valve support on the valve.
- The AV valves must be used within the specifications specifically applicable to the Product.
- If the actuator is used in an environment below 5°C temperature, its operating fluid must be free from the water and moisture contained in it because of possible problems due to the freeze.
- The operating fluid must be clean air filtered through a pertinent air filter.

### (3) General instructions for transportation, unpacking and storage



- When suspending and supporting a valve, take care and do not stand under a suspended valve.

Warning



- This valve is not designed to handle impacts of any kind. Avoid throwing or dropping the valve.

Caution

- Avoid scratching the valve with any sharp object.

- Do not over-stack cardboard shipping boxes. Excessively stacked packages may collapse.

- Avoid contact with any coal tar creosote, insecticides, vermicides or paint.

(These chemicals may cause damage to the valve.)

- When transporting a valve, do not carry it by the handle.



- Store products in their corrugated cardboard boxes. Avoid exposing products to direct sunlight, and store them indoors (at room temperature). Also avoid storing products in areas with excessive temperatures. (Corrugated cardboard packages become weaker as they become wet with water or other liquid. Take care in storage and handling.)

- After unpacking the products, check that they are defect-free and meet the specifications.

(4) Name of parts

**Type 75, 75D: 450-600mm (18"-24")**

**Body Material: PP, PVDF, PDCPD\***

\*Body material PDCPD (type 75D) is different from the drawing below.

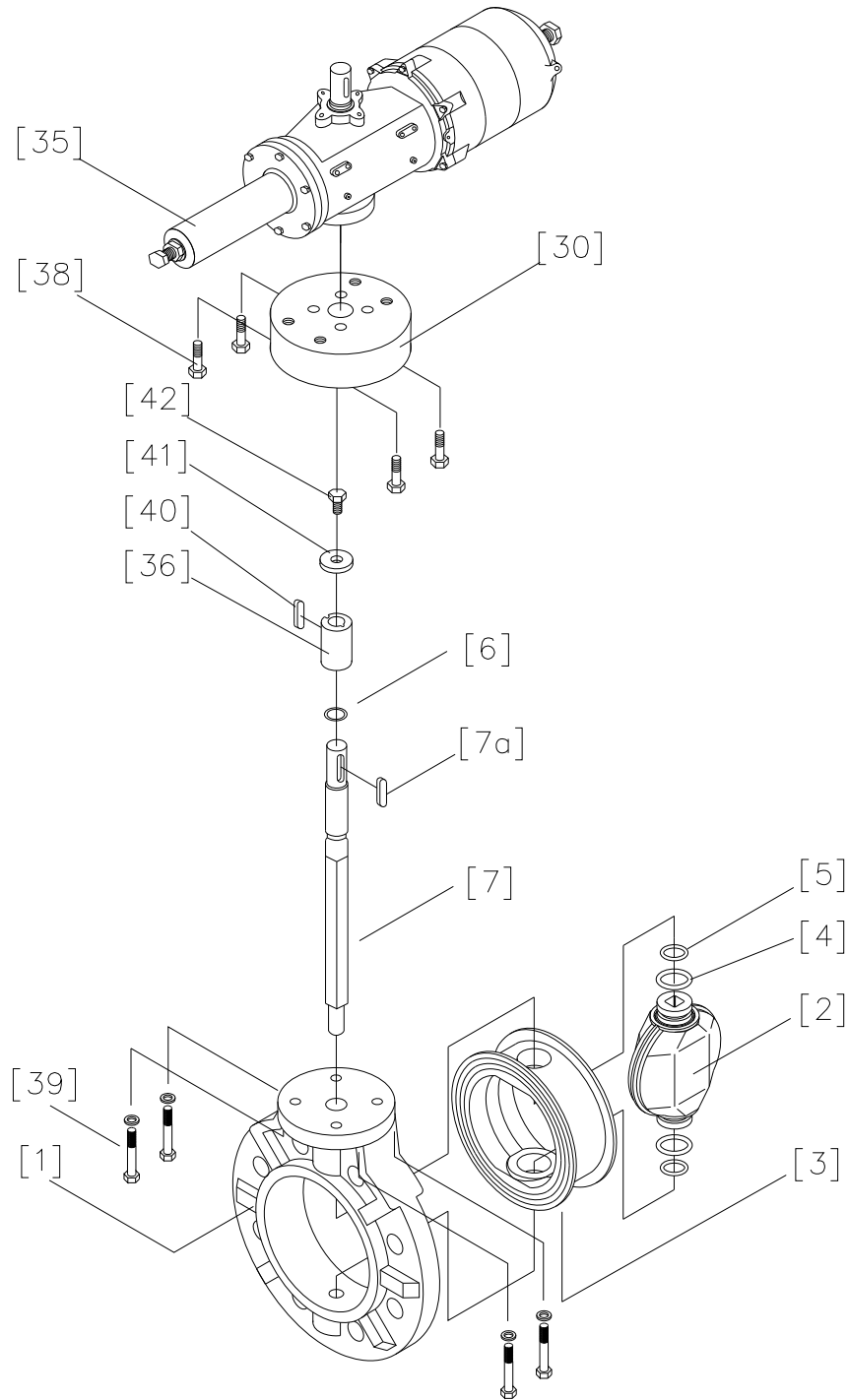

No.	DESCRIPTION	No.	DESCRIPTION	No.	DESCRIPTION
[1]	Body	[7]	Stem	[39]	Bolt (K)
[2]	Disc	[7a]	Key (A)	[40]	Key (B)
[3]	Seat	[30]	Stand	[41]	Washer (B)
[4]	O-ring (A)	[35]	Actuator	[42]	Bolt (F)
[5]	O-ring (B)	[36]	Stem Bush		
[6]	O-ring (C)	[38]	Bolt (E)		

(5) Working pressure vs. temperature

**BUTTERFLY VALVE TYPE 75**

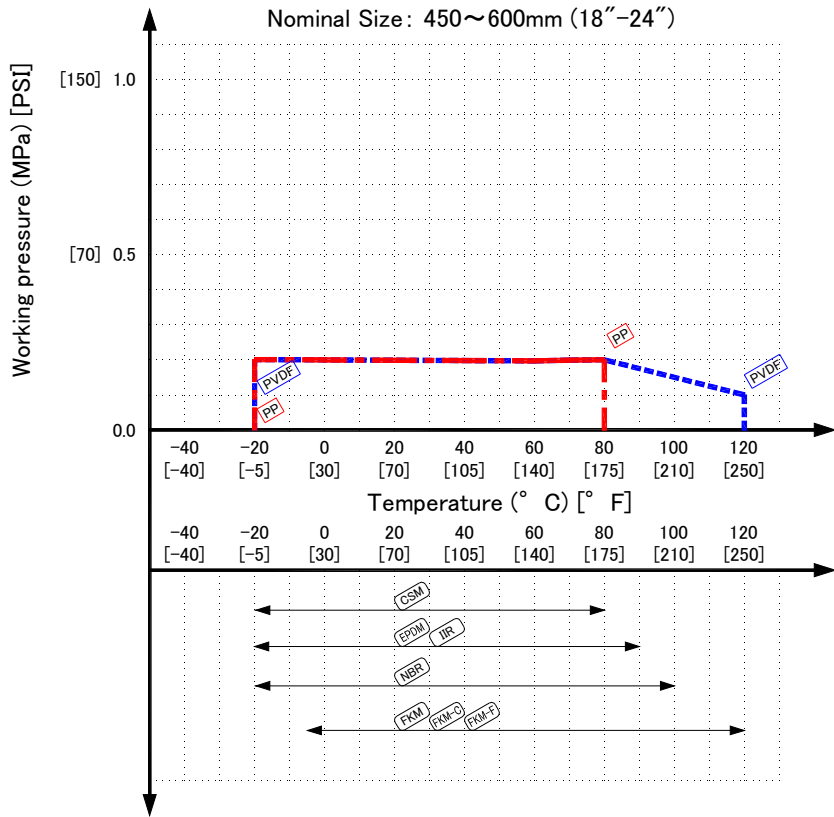

**BUTTERFLY VALVE TYPE 75D**

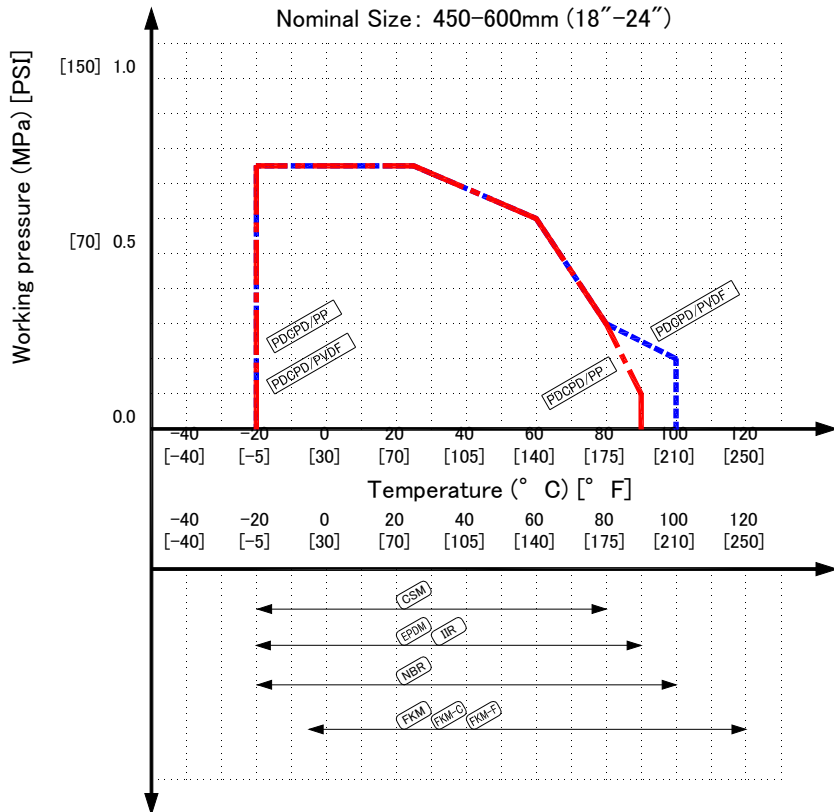

(6) Specifications of Actuator

Actuation	Nominal Size (mm) {inch}	Actuator name	Angle adjustment range	Standard operating pressure MPa {kgf/cm <sup>2</sup> }	Air consumption N l per 1 open and close (at 0.4MPa)	Air supply bore
Double Action Type	450-600mm (18"-24")	TW-250D	±5°	0.4 {4.1}	99	Rc 3/8

(7) Specification of solenoid valve (Option)

Actuation	Nom. size	Type sign	Pipe bore	Effective cross section area	Power consumption	Additional function
Double actuation Type	450-600mm (18"-24")	453S403C-W□	Rc 3/8	40mm <sup>2</sup> or more	AC ; 6VA DC ; 5.5W	○ Bypass valve built-in ○ Silencer with needle valve attached (to be used as speed controller)

453S403C-W□

※ ( ) is special order.

Specification	sign
AC100V 50/60Hz	1
AC110V 50/60Hz	(2)
AC200V 50/60Hz	3
AC220V 50/60Hz	(4)
DC24V	5
DC48V	(6)
DC100V	(7)
DC125V	(9)

connection diagram

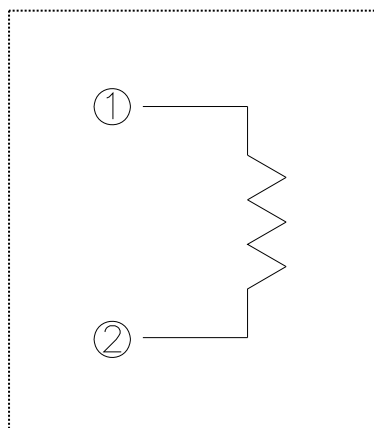

JIS sign

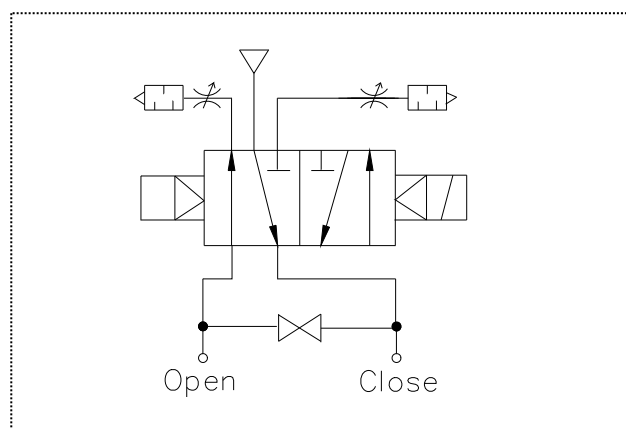

**(8) Specifications of limit switch (Option)**

Actuation	Nom. size	Type sign	Protection grade	Type of limit switch
Double actuation Type	450-600mm (18"-24")	—	IP67	ILS1-J (made by Yamatake)

Limit switch rating

Rate voltage (V)	resistive load (A)	Inductive load (A)
AC125	10	6
AC250	10	6
DC125	0.8	0.2
DC250	0.4	0.1

Connection diagram

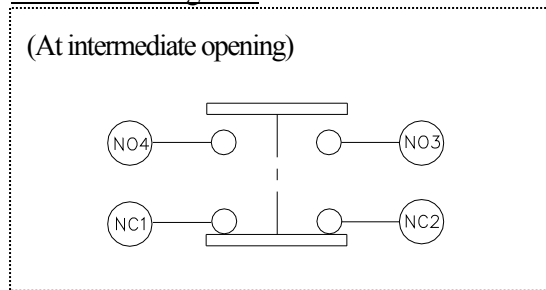

**(9) Specification of pressure reducing valve with filter (Option)**

Actuation	Nominal size(mm)	Type sign	Pipe bore	Element degree Of filtration
Double actuation Type	450-600mm (18"-24")	ARU3A-03-10A	Rc 3/8	40µm

JIS sign

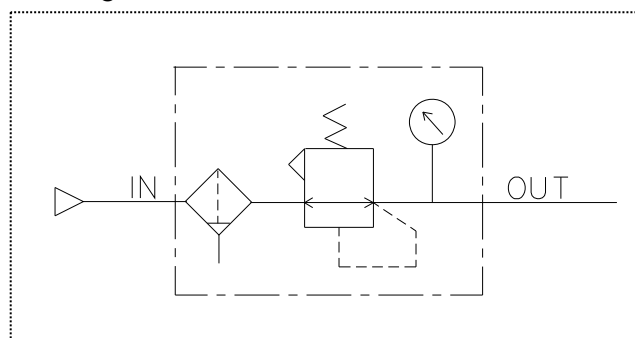



(10) Specification of speed controller (Option)

Actuation	Nom. size(mm)	Type sign	Pipe bore	Effective cross section area (mm <sup>2</sup> )		Needle No. of revolution
				Free flow	Control flow	
Double actuation Type	450-600mm (18"-24")	SC6-04-10 A	Rc 3/8	38	32	20turns

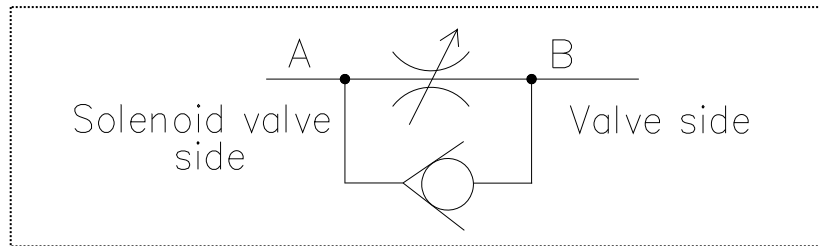

(11) Installation procedure

**Warning** ⚠️ - When suspending and supporting a valve, take care and do not stand under a suspended valve.

**Caution** ⚠️

- Be sure to conduct a safety check on all hand and power tools to be used before beginning work.
- Wear protective gloves and safety goggles as fluid remain in the valve even if the pipeline is empty. (You may be injured.)
- When installing a pipe support by means of a U-band or something similar, take care not to over-tighten. (Excessive force may damage the pipe.)
- When installing pipes and valves, ensure that they are not subjected to tension, compression, bending, impact, or other excessive stress.
- Use flat faced flanges for connection to AV Valves.
- Ensure that the mating flanges are of the same standards.
- The gasket is unnecessary. (The seat carries out the role of the gasket.)
- The valve disc is in the position indicated by solid lines in figure to the right prior to shipment from the factory. If the valve is opened or closed after unpacking, it must be reset in this position before installation. Failure to do so will result in damage to the surface of the valve seat during handling and installation.



- Care must be used during piping installation to ensure that the pipes or flanges are properly aligned so that the valve disc does not contact them in any setting. Misalignment as in Figure below will result in damage to the valve.

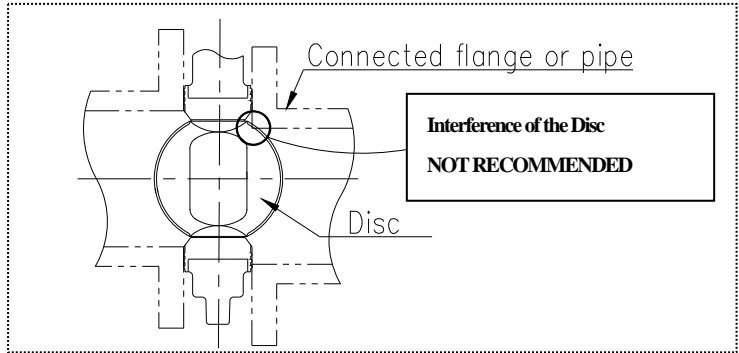

In the case of thick of the connection part (flange and pipe) is too thick shave the flange or the pipe inside order to avoid the contact of pipe and disk. If inside diameter of the connection part is larger than size D, shaving is not necessary.

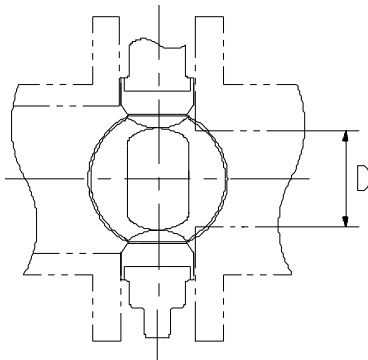

Unit: mm (inch)

Nominal size		Diameter D	
450	(18")	422	(16.61")
500	(20")	472	(18.58")
600	(24")	572	(22.52")

**Necessary items**

- Torque wrench
- Bolt, Nut, Washer (For many flanges specification)
- Spanner wrench

**Procedure**

- 1) Leave the valve slightly opened by spanner wrench.
  - \* Don't turn the disc beyond the seat. (Otherwise, the disc may be damaged.)
- 2) Set the valve between the coupled flange.
- 3) Insert washers and bolts from the pipe side, insert washers and nuts from the valve side, then temporarily tighten them by hand.
- 4) Using a torque wrench, tighten the bolts and nuts gradually to the specified torque in a diagonal manner. (Refer to fig.1.)
  - \* Avoid excessive tightening. (The valve can be damaged.)

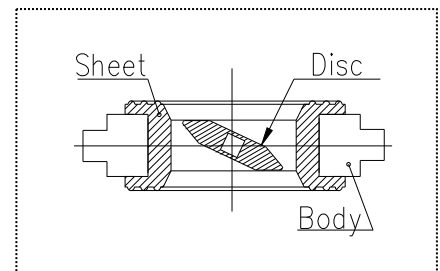

- Tighten the bolts and nuts gradually with a torque wrench to the specified torque level in a diagonal manner.

	Recommended torque value		Unit: N·m {kgf·cm} [lb·inch]
Nom. Size	450mm (18")	500, 600mm (20", 24")	
Torque value	80.0	100.0	
	{816}	{1020}	
	[710]	[887]	

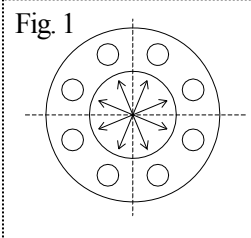

**JIS Standard (10K)**

Body Material: PP, PVDF, PDCPD

Nominal Size mm (inch)	Bolt A			Bolt B		Quantity		
	D	L	S	D1	L1	Bolt A	Bolt B	Nut & Washer
450 (18")	M24	more than 310mm (12.20")	65mm (2.56")	M24	more than 120mm (4.72")	16	8	40
500 (20")		more than 320mm (12.60")						
600 (24")	M30	more than 350mm (13.78")	75mm (2.95")	M30	more than 140mm (5.51")	20		48

Bolt A

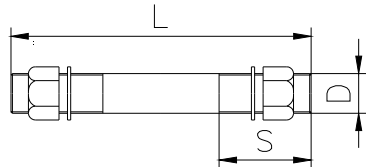

Bolt B

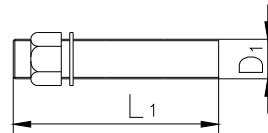

Caution

- The parallelism and axial misalignment of the flange surface should be under the values shown in the following table to prevent damage the valve.

(A failure to observe them can cause destruction due to stress application to the pipe)

Unit : mm (inch)

Nom. Size	Axial Misalignment	Parallelism (a-b)
450-600mm (18"-24")	1.5 (0.06)	1.0 (0.04)

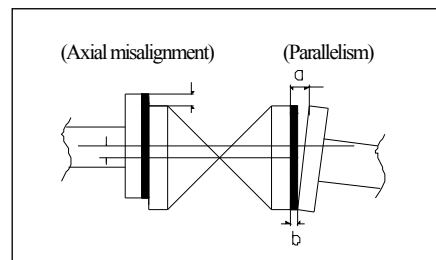

- When you insert a valve between flanges, please insert after extending the fields of flanges fully. (If you insert a valve by force without fully extending fields of flanges, a liner may be turned over and suffer a crack.)

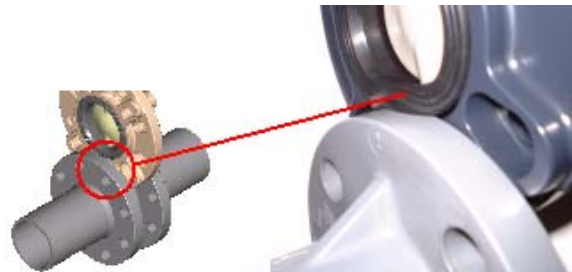

(12) Support setting procedure



- Set the valve support. (If not, the valve may be damaged because the actuator is heavy.)
- Do not subject the valve to pump vibration. (The valve may be damaged.)

Necessary items

- Spanner wrench
- U-type clamp (with bolt)
- Rubber sheet

Level installation

Set the stand under the valve.

Spread the rubber sheet on the pipe and secure pipe with U-type clamp.

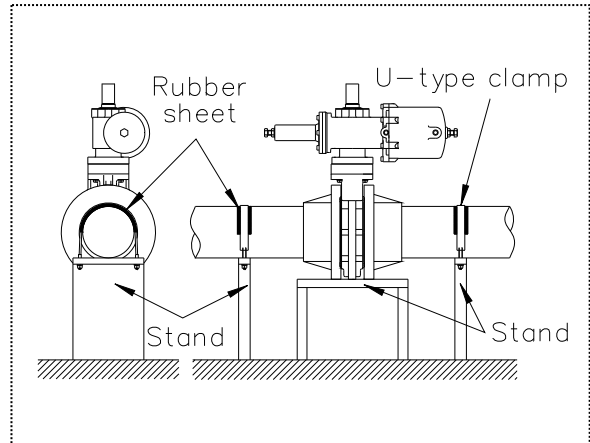

Perpendicular installation

Spread the rubber sheet under the actuator.

Spread the rubber sheet on the pipe and secure pipe with U-type clamp.

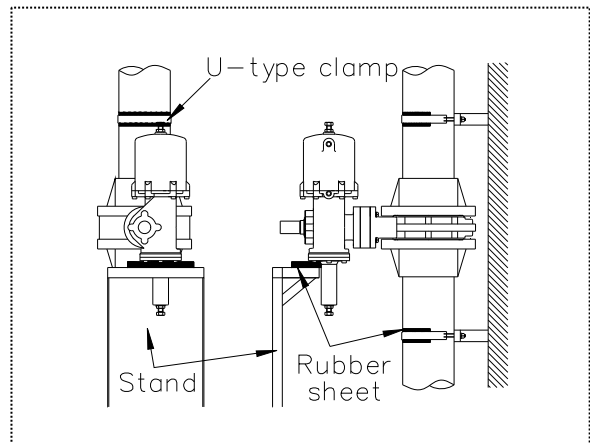

**(13) Air piping procedure**

<1> For a standard type and an attached speed controller type

**Caution**

- Do not remove a dust-proof cap provided to piping port before piping work starts.
- Avoid excessive tightening. (The threaded area of a pipe can be damaged.)
- The operating fluid must be clean air filtered through a pertinent air filter.
- If the actuator is used in an environment below 5°C temperature, its operating fluid must be free from the water and moisture contained in it because of possible problems due to the freeze.
- Steel pipes must always be of the plated.
- Before installing an actuator in pipeline, flash the inside of pipeline completely.
- Do not apply a sealant excessively lest it fall off in the pipeline when an actuator is piped.
- Threaded area of a pipe must be free from the sharp edges and burr.

Necessary items

- Spanner wrench
- Steel pipe or tube for piping
- Seal tape (If seal tape isn't used, leakage may be caused)
- Joint for steel pipe or tube

Procedure

- 1) Wind a seal tape onto the male screw of the joint with a blank about 3mm (about 2 threads) left at the end.
- 2) Screw the joint in the piping female screw of the actuator by hand to the full.
- 3) Screw the joint one turn with a spanner wrench.  
\* Avoid excessive tightening.  
(The valve can be damaged.)
- 4) Mount a steel pipe or a tube.

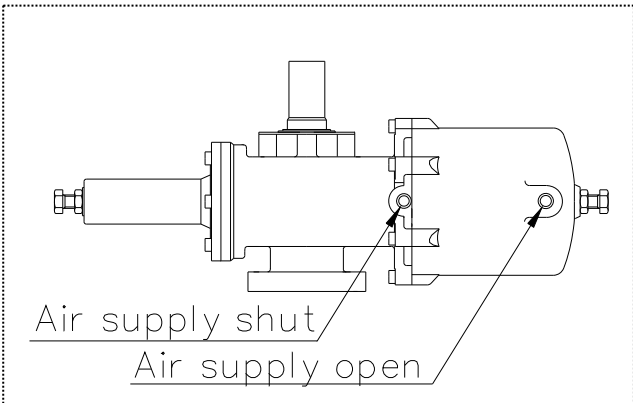

\*The diagrams left are without speed controllers, however, air piping procedure is the same way as above.

<> For a pressure reducing valve with a solenoid valve and a pressure reducing valve with a filter.

**Caution**

- Do not remove a dust-proof cap provided to piping port before piping work starts.
- Avoid excessive tightening. (The threaded area of a pipe can be damaged.)
- Steel pipes must always be of the plated.
- Before installing an actuator in pipeline, flash the inside of pipeline completely.
- Do not apply a sealant excessively lest it fall off in the pipeline when an actuator is piped.
- Threaded area of a pipe must be free from the sharp edges and burr.
- Open the drain periodically in order to exhaust the deposit.
- The equipment must be used at a pressure below the maximum operating pressure specified for the product.

**Necessary items**



- Spanner wrench
- Seal tape (If seal tape isn't used, leakage may be caused)
- Steel pipe or tube for piping
- Joint for steel pipe or tube



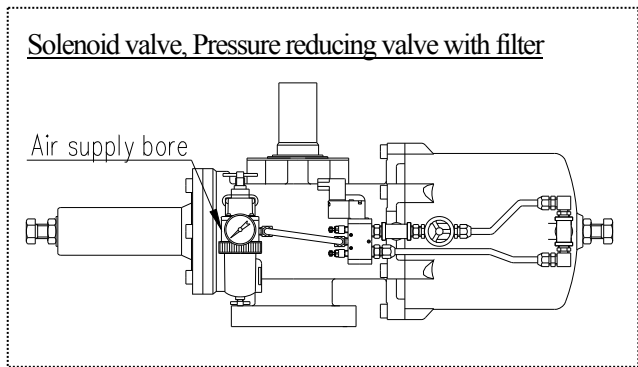
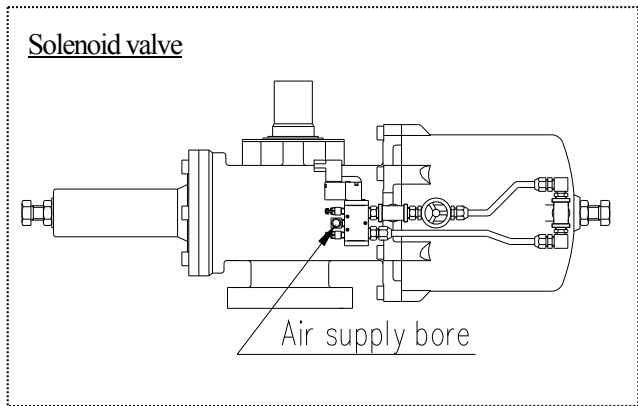

Procedure

- 1) Wind a seal tape onto the male screw of the joint with a blank about 3mm (about 2 threads) left at the end.
- 2) Screw the joint in the piping female screw of the actuator by hand to the full.
- 3) Screw the joint one turn with a spanner wrench.  
\*Avoid excessive tightening. (The valve can be damaged.)
- 4) Mount a steel pipe or a tube.



**(14) Connection of limit switch procedure**

- Warning**  - Shut down the power on the equipment before connecting wires. There are risks of electrical shock depending on the level of operating voltage.
- Caution**   - Be sure that the cover are put on during the operation.
- Connect the cables by using insulated sheathed crimping terminals in such a way as not to contact the cover or housing. (Contact of a crimping terminal with the cover may disable the cover from being closed or may cause a ground fault.)
  - If you use the limit switch at 1mA-100mA or 5-30V, consult near Asahi dealer.
  - Be sure that the terminal cover and body cover are put on during the operation.

- Necessary items**
-  Screw driver (+)
  -  Connector (G1/2)
  -  Crimp-style terminal
  -  Terminal crimping tool
  -  Wire stripper

Procedure

- 1) Loosen the three screws used to attach the limit switch cover with a screwdriver (+) and remove cover from the limit switch. (The screw is made so that it will not detach from the cover.)
  - 2) Pull and remove protective cap, made of resin, from the cover.
  - 3) Draw a cable through the connector.
  - 4) Strip cable with a wire stripper.
  - 5) Connect terminal screw with a screwdriver (-) according to the internal circuit diagram shown in page 6.
- \* Tighten up the screws. (Short circuit may occur.)

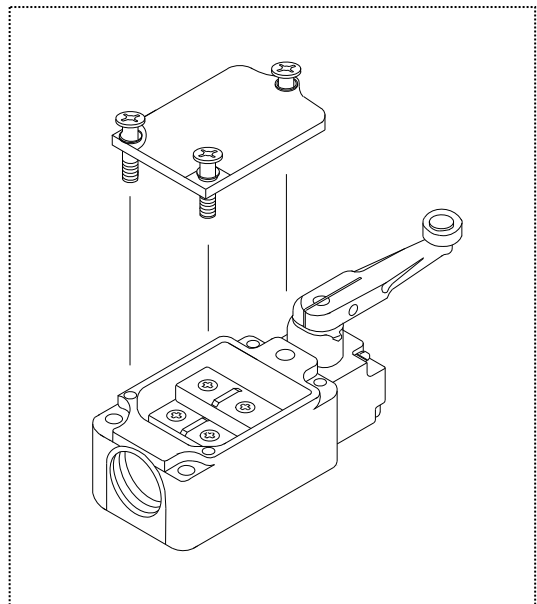
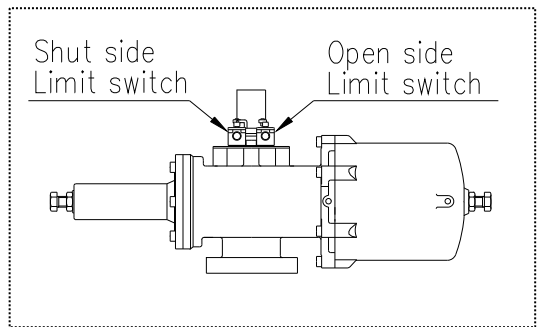

**(15) Connection of solenoid valve procedure**

 - Go after you surely interrupt a power supply when you do the installation of the terminal base line is combined.

- Necessary items
- Terminal crimping tool
  - Connector (G1/2)
  - Screw driver (+)
  - Wire stripper

Procedure

- 1) Loosen the hexagon socket head cap screws, and remove the cover.  
\* Don't loose O-ring. (Short circuit may occur.)
- 2) Remove the Faston terminal inserted into coil side and the insulating sleeve.  
\* Insulating sleeve isn't attached in Faston terminal.
- 3) Draw the cable through the connector to the cover.
- 4) Strip the cable with wire stripper.
- 5) Draw the lead wire through the cover.
- 6) Install the Faston terminal on the lead wire with a terminal-crimping tool.
- 7) Insert the Faston terminal into the coil side, and fit the cover.
- 8) Tighten the cover setting screws to fix it.  
(The cover can be set with the wire extraction opening turned upward or downward.)
- 9) Tighten the cable by connector.

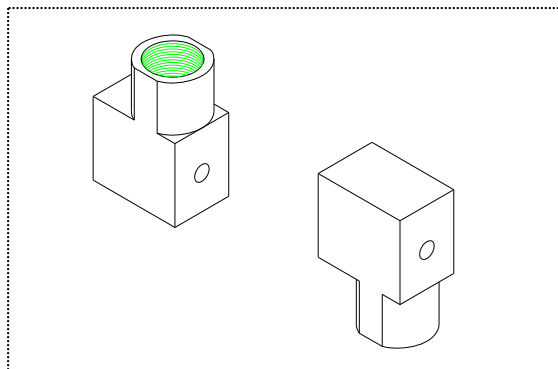
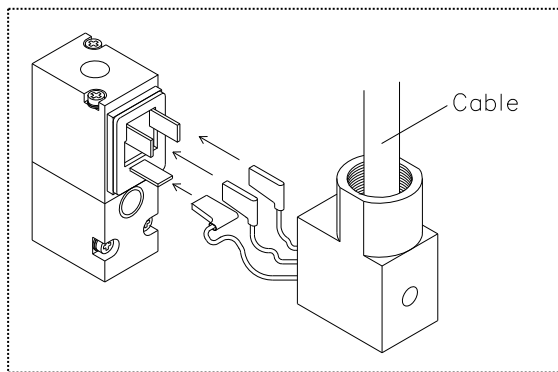
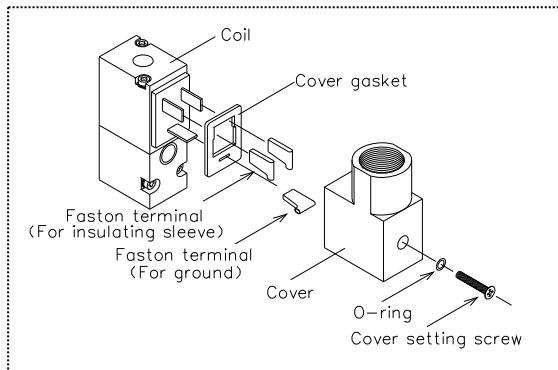



(16) Operating procedure

Manual Operating Procedure

Necessary items  
 ● Padlock

- \* Don't supply air during manual operation. (Injury may occur.)
- Don't remove the indicator. (A trouble may develop.)
- Only for the actuator which is the manual operation with groove.

Procedure

\* In case of solenoid valve mounted, open the bypass valve to make atmospheric pressure in the actuator.

- 1) Open the padlock and release the chain.
- 2) Turn the handle full open or full close.

Right turn (clock wise) → Shut direction

Left turn (counter clock wise) → Open direction

- \* Do not turn the lever handle (option) or spanner wrench forcibly at the right and left full operating positions. (A trouble will develop.)
- There are about thirteen idle turns between full open and full close.

- 3) Turn the handle to adjust the nut to "AUTO" of the indicator.
- 4) Lead the chain through the handle and the gear case and tighten up with the pad lock.

- \* In case of solenoid valve mounted, turn the bypass valve right. (If not, the air leaks.)

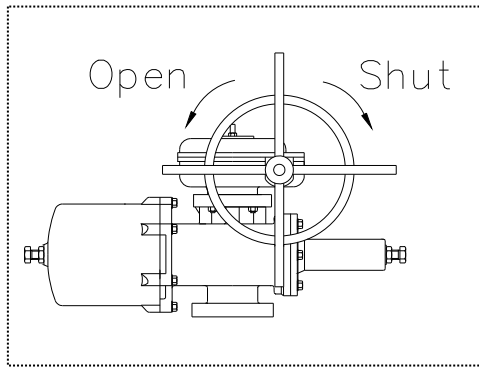
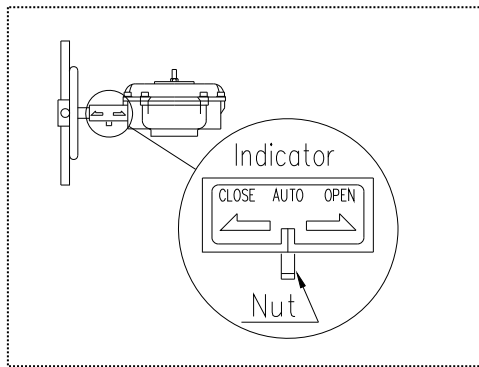
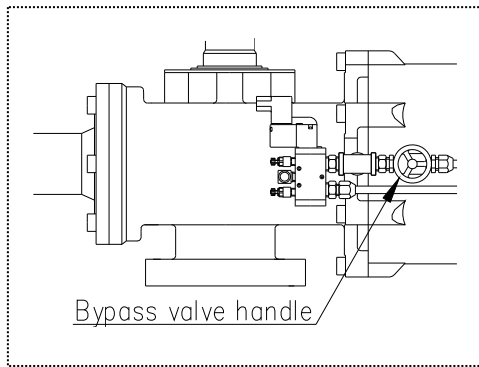

Automatic (Air) Operating Procedure

**Warning**  - Make sure that the manual handle (Option) or spanner wrench is not attached to the output shaft in the upper part of the actuator securely.  
 (Otherwise the manual handle (Option) or spanner wrench will be flung off by the rotation of the output shaft and the manual handle (Option) or spanner may injure you.)

**Caution**  - Keep air supply pressure from a compressor at least 0.4 MPa (4.1kgf/cm<sup>2</sup>).  
 (Actuator may not work normally.)  
 - The AV valves must be used within the specifications specifically applicable to the product.

Procedure

- 1) Supply the air to the actuator.
- 2) Check to ensure that the valve indicating direction and the operating direction agree with each other.
- 3) Stop air supply.

(Standard)

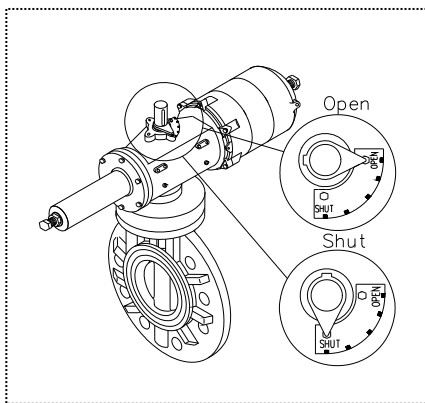

(With manual operating option)

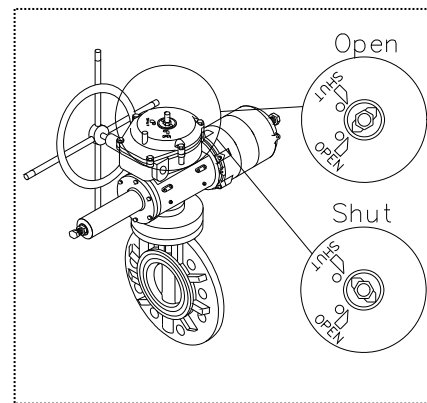

<For the solenoid valve>

Procedure

- 1) Supply the air to the solenoid valve.
- 2) Push the button with a finger, and confirm the action mode shown in the following table.
- 3) Apply regular rated voltage to the solenoid valve, and confirm the action mode shown in the following table.
- 4) Turn off the solenoid valve.

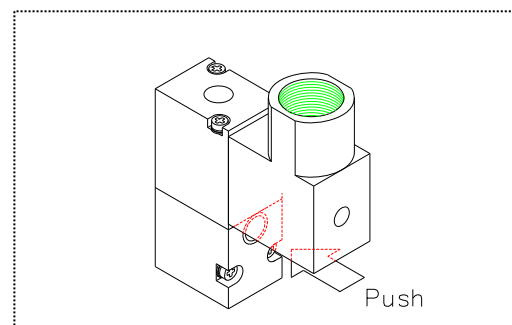

Push button	Current	Double action
Pushed	On	Open
Not pushed	Off	Shut

Adjustment of opening / closing speed procedure

 - Fasten a lock nut after adjusting a speed controller of solenoid valve.  
Caution

○ Double action type

Necessary items  
● Spanner wrench

Procedure

- 1) Release the adjustment knob of the solenoid valve by turning the locking nut left.
- 2) Turn right the adjustment knob of the solenoid valve fully.  
\* Avoid excessive tightening.  
(The speed controller can be damaged.)
- 3) Supply the air to the solenoid valve.
- 4) Apply regular rated voltage to solenoid valve, and turn the open side adjustment knob of the speed controller left little by little.
- 5) Turn off the solenoid valve, and turn left the close side adjustment knob little by little.
- 6) Repeat item 4), 5) to adjust the opening / closing speed required.
- 7) When the adjustment is finished, fix the adjustment knob by turning locking nuts right.  
\* Avoid excessive tightening.  
(The speed controller can be damaged.)

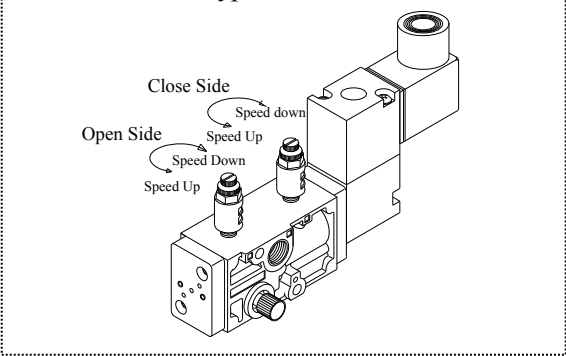

For Double action type with solenoid valve

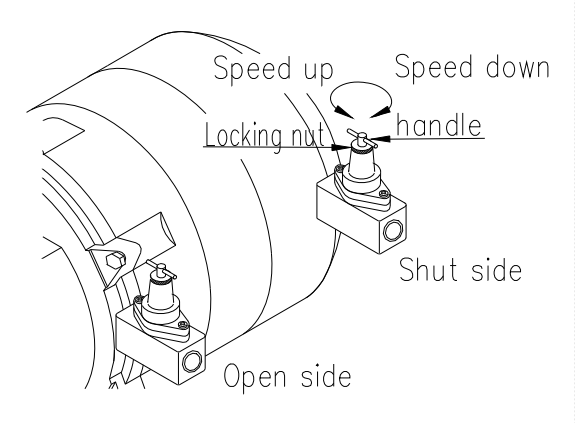

For Double action type with speed controller



**(17) Disassembling method for replacing parts**

  - Wear protective gloves and safety goggles as fluid remain in the valve even if the pipeline is empty. (You may be injured.)

- When installing pipes and valves, ensure that they are not subjected to tension, compression, bending, impact, or other excessive stress.

- Do not change or replace valve parts under line pressure.

- Necessary items
- Jack
  - Pipe
  - Plate
  - Pliers
  - Thrust bearing
  - Allen wrench
  - Protective gloves
  - Safety goggles

<Disassembly>

Procedure

- 1) Completely discharge fluid from pipes.
- 2) Fully close the valve by the automatic operation or manual operation. (Refer to page16)
- 3) Stop the air supply, and open the bypass valve to exhaust the air in actuator.
- 4) Remove the air piping.
- 5) Leave the valve slightly opened by using the lever handle (option).
- 6) Loosen and remove the connecting bolt-nut.
- 7) Remove the valve from the pipe.
- 8) Loosen the bolt (K) [39], and remove the body [1] and the actuator [35].  
\* The stand [30] is fixed to the actuator [35] by the bolt (E) [38].
- 9) Attach the jack, the thrust bearing, plate and the pipe to the valve, and thrust the jack into the stem [7].
- 10) Turn the handle of jack to pull out the stem [7].
- 11) Remove the stem [7] from the jack.
- 12) Remove the O-ring (C) [6].
- 13) Make the disc 2 fully open.
- 14) Remove the disc [2] from the seat [3].
- 15) Remove the O-ring (A) [4] and the O-ring (B) [5].

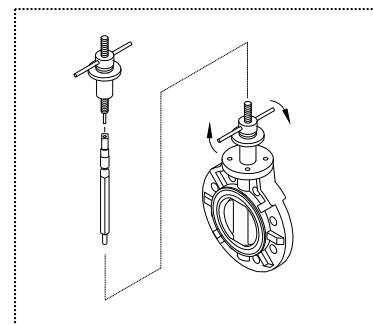
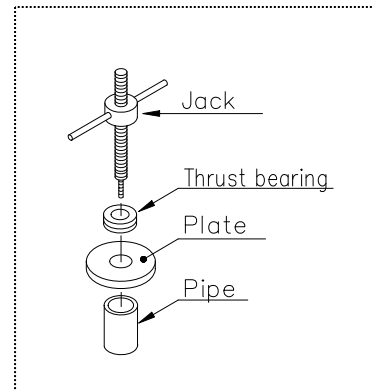
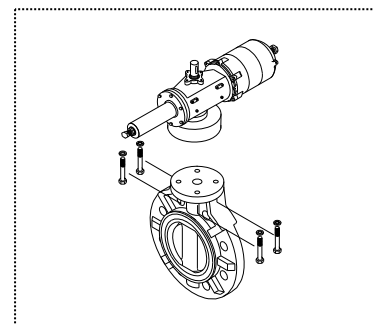
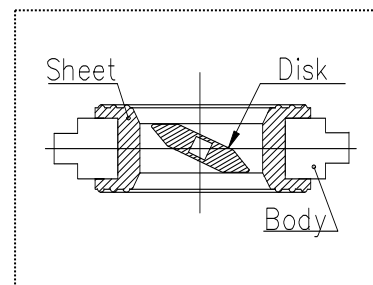

<Assembly>

Procedure

1) Before starting assembly, silicone grease (equivalent to Toray Silicone HVG) should be spread on the disc O-ring (A) [4], (B) [5] and stem O-ring (C) [6].

2) The procedure of the assembly is the almost reverse of its disassembly.

However, to insert seat [3] with the disc [2] into the body [1], set the disc [2] with half-opened position. Press outer rim of seat [3] into inside of the body [1], keeping stem holes straight. (Make sure that stem holes of the seat [3] are in alignment with the stem holes of the body [1].)

3) Make sure that the disc [2] fits seat [3] well.

4) Check to ensure that travel indicator shows correct position of fully open or close.

5) Fully open or close the valve by air operation. (Refer to page16)

\*In case that the travel indicator shows incorrect position of fully open or close, adjust it according to “18 Stopper adjustment procedure”.

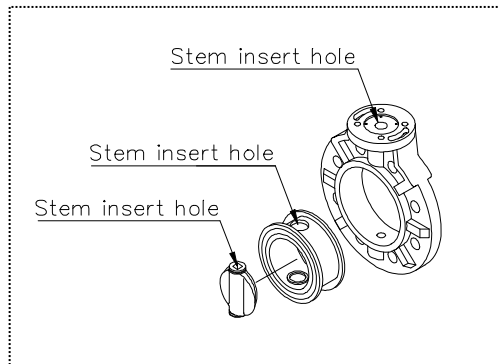

**(18) Stopper adjustment procedure**

Necessary items

- Spanner wrench

\* Don't supply air during manual operation.

(When air is supplied during the manual operation, injury may occur.)

Procedure

1) Stop the air supply, and open the bypass valve to exhaust the air in actuator.

2) Attach the spanner wrench or the hexagon wrench to stopper, and loosen the locking nut with the spanner wrench slowly.

\* Don't damage the seal washer. (Otherwise, the air may leak.)

3) Turn the stopper with the spanner wrench or the hexagon wrench to adjusting direction.

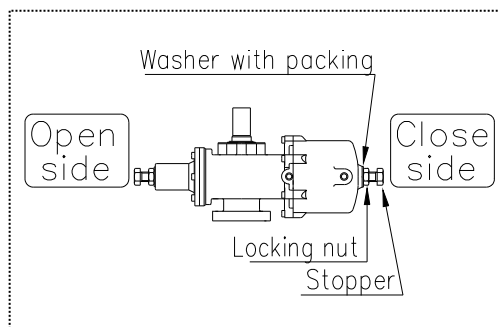

\*Avoid excessive tightening. (Otherwise, the air may leak.)



Direction	Clock wise	Counter clock wise
Open side	Smaller	Larger
Close side	Larger	Smaller

4) Close the bypass valve, and supply the air to the actuator. Operate the valve with air to make sure that opening degree is adjusted correctly.

(19) Inspection items

  - Perform periodic maintenance. (Leakage may develop due to temperature changes or over periods of prolonged storage, rest or operation.)



Portion to be inspected	Inspection item
Actuator	<ul style="list-style-type: none"> <li>- Existence of rust, peeling of paint, and corrosion around the actuator.</li> <li>- Tightening condition of respective threaded portions. (Loose or not)</li> <li>- Existence of abnormality in opening and closing operating sounds.</li> <li>- Smooth operation of manual handle.</li> </ul> <p>※This actuator can be used without oiling. However, if lubricating oil is used, use addition turbine oil specified follow: JIS K 2213 Addition Turbine oil (ISO VG 32, 46)</p>
Valve	<ul style="list-style-type: none"> <li>- Existence of scratches, cracks, deformation, and discoloring.</li> <li>- Existence of leakage from the valve to the outside.</li> <li>- Existence of leakage when the valve is closed fully.</li> </ul>

(20) Troubleshooting

Problem	Cause	Treatment
The handle is not (can't be) turned when the valve is operated manually.	The valve has already been opened fully.	Turn the handle in the reverse direction. (Refer to page 16.)
	The air is supplied to actuator.	Shut the main air valve, and open the bypass valve.
	Foreign matter is in the valve.	Disassemble the valve to remove foreign matter. (Refer to page 8.)
	The torque of the valve is increased by the piping stress.	Remove the piping stress. (Refer to page 8.)
	The torque is increased by the influence (temperature, components, pressure) of fluid on the valve.	Check service condition. (Refer to page 5)
The valve does not operate by air operations	The power source of the solenoid valve is turned off.	Turn on the power source.
	The solenoid valve is disconnected.	Check the connection again. (Refer to page 6)
	The air is not supplied to actuator.	Supply the air.
	The supply voltage to the solenoid valve is wrong.	Check the voltage with a tester and set specified voltage.
	The voltage to the solenoid valve is low.	
	The bypass valve is opened.	Turn the knob of the bypass valve right to close. (Refer to page 16)

Problem	Cause	Treatment
The valve does not operate by air operations	Adjustment knob of speed controller is turned right fully.	Turn the adjuster knob left. (Refer to page 18)
	Foreign matter is in the valve.	Disassemble the valve to remove foreign matter. (Refer to page 8)
	The torque of the valve is increased by the piping stress.	Disassemble the valve to remove the piping stress. (Refer to page 8)
	The torque is increased by the influence (temperature, components, pressure) of fluid on the valve.	Check service condition. (Refer to page 6)
Fluid leaks from the valve even when the valve is closed fully.	The seat is worn.	Replace the seat with a new one. (Refer to page 19)
	The seat and ball are scratched.	Replace the scratched seat and ball with new ones.
	Foreign matter is in the valve.	Discharge the foreign matter from the valve by opening and closing the valve several times. (Refer to page 16)
	The connecting bolts are not tightened in proper torque or evenly.	Adjust and retighten. (Refer to page 8)
Fluid leaks from the valve.	The O-ring is scratched or worn.	Replace the O-ring with a new one. (Refer to page 19)
	The O-ring is projected from the groove.	
	The sliding face or the fixed face of the O-ring is scratched or worn.	Replace the sliding face or the fixed face with a new one. (Refer to page 19)
The actuator operates, but the valve is not open or close.	The stem or the joint is broken.	Replace the stem or the joint with a new one. (Refer to page 19)
	The engagement between the stem and the ball is broken.	Replace the engagement with a new one. (Refer to page 19)

(21) Handling of residual and waste materials

  - Make sure to consult a waste treatment dealer for recommendations on the proper disposal of plastic valves. (Poisonous gas is generated when the valve is burned improperly.)

**Butterfly Valves Type 75, 75D  
Pneumatic Actuated Type TW**

[Automatic Valve]



ASAHI AV VALVES

---

Asahi Organic Chemicals Industry's homepage

<http://www.asahi-yukizai.co.jp/en/>