

Ilumiline 21 IP Optic Series

User Manual

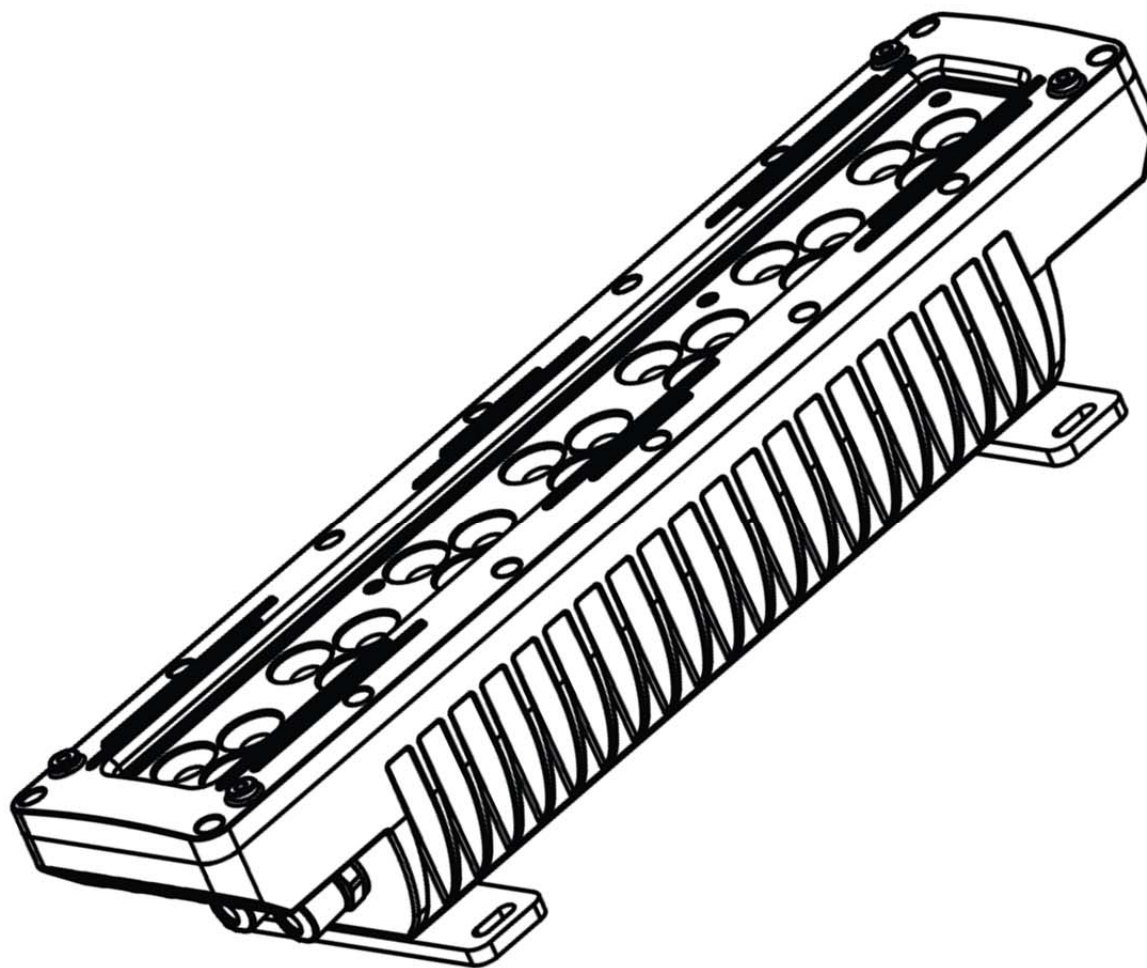

ILUMINARC®

Edition Notes

The Ilumiline 21 IP Optic Series User Manual Rev. 05b covers the description, safety precautions, installation, programming, operation, and maintenance of the Ilumiline 21 IP Optic Series. ILUMINARC® released this edition of the Ilumiline 21 IP Optic Series User Manual Rev. 05b in July 2011.

Trademarks

The ILUMINARC® logo, the ILUMINARC® name and all other trademarks in this document related to services or products by ILUMINARC® are trademarks owned or licensed by ILUMINARC®, its affiliates or subsidiaries. Any other product names, logos, brands, company names, or trademarks featured or referred to within this document are the property of their respective trademark holders.

Copyright Notice

The entire content of this document, except where applicable and unless otherwise noted, is solely owned by ILUMINARC®, a wholly owned trademark of CHAUVET & Sons Inc.

© Copyright 2011 ILUMINARC®

All rights reserved

Electronically published by ILUMINARC® in the United States of America

Manual Usage

ILUMINARC® authorizes its customers to download and print this manual for professional information purposes only. ILUMINARC® expressly prohibits the usage, copy, storage, distribution, modification, or printing of this manual or its content for any other purpose without its written consent.

Document Printing

For better results, print this document in color, on letter size paper (8.5 x 11 inches), double sided. If using A4 paper (210 x 297 mm), configure your printer to scale the content of this document to A4 paper.

Intended Audience

Any person in charge of installing, operating, and/or maintaining the Ilumiline 21 IP Optic Series should read the Guide that shipped with it and this manual in their entirety before installing, operating, or maintaining this product.

Disclaimer

ILUMINARC® believes that the information contained in this manual is accurate in all respects. However, ILUMINARC® assumes no responsibility for any error or omissions in this document. ILUMINARC® reserves the right to revise this document and to make changes from time to time in the content hereof without obligation of ILUMINARC® to notify any person or company of such revision or changes. This does not constitute in any way a commitment by ILUMINARC® to make such changes. ILUMINARC® may issue a revision of this manual or a new edition of it to incorporate such changes.

ILUMINARC® Publications Hot Line

If you have any comments about the accuracy of this document or general suggestions regarding how we can improve it, please call us at (954) 923-3680. You can download the latest versions of all ILUMINARC® products' manuals from www.iluminarc.com.

Document Revision

The Ilumiline 21 IP Optic Series User Manual Rev. 05b supersedes all previous versions of this manual. Please discard any older versions of this manual you may have, whether in printed or electronic format, and replace them with this version.

Table of Contents

- 1. Introduction.....1**
 - What is in the Box 1
 - Unpacking Instructions 1
 - Text Conventions 1
 - Safety Notes 2
 - Personal Safety*2
 - Mounting and Installation*.....2
 - Power and Wiring*2
 - Operation*.....2
- 2. Product Description 3**
 - Common Features..... 3
 - Ilumiline 21 IP Optic RGB Features*.....3
 - Ilumiline 21 IP Optic SpectraWhite™ Features*.....3
 - Additional Features*.....3
 - Product Dimensions 4
- 3. Installation 5**
 - AC Power 5
 - Input Voltage and Frequency*.....5
 - Power Consumption*5
 - Power Wiring*5
 - Signal Wiring*5
 - External Wiring 6
 - Power Distribution*6
 - Signal Distribution*.....6
 - Controllers 7
 - DMX Controller*.....7
 - ILUMICON*.....7
 - Ilumicode*8
 - Mounting..... 8
 - Orientation*.....8
 - Rigging*8
 - Procedure*.....8
- 4. Operation 9**
 - Ilumicode 9
 - Ilumicode Panel Description*9
 - Menu Map 9
 - White Functions Menu Map*.....9
 - RGB Functions Menu Map*10
 - Programming..... 11
 - DMX Personality*.....11
 - DMX Starting Address*11
 - Dimmer*.....11
 - ILUMICON Control*12
 - Static Color*12
 - Color Calibration*.....12
 - Color*.....12
 - Reset*.....12
 - DMX Values 13
 - ARC 1*.....13
 - ARC 1 + D*.....13
 - ARC FULL*13
 - VW*.....14
 - VW + D*.....14
 - SOLID*.....14

5. Technical Information	15
Product Maintenance	15
Product Repairs.....	15
Troubleshooting Guide	16
Photometrics	17
LED Disclaimer.....	23
<i>LED Life</i>	23
<i>LED Binning</i>	23
<i>Color Rendering Index (CRI)</i>	23
Returns Procedure	24
Claims.....	24
Contact Us.....	24
Technical Specifications.....	25
<i>Illumiline 21 IP Optic RGB</i>	25
Technical Specifications.....	26
<i>Illumiline 21 IP Optic VW</i>	26

1. Introduction



This icon indicates useful, although non-critical information.



This icon indicates important installation or configuration information. Failure to comply with this information may prevent the product from functioning correctly.



This icon indicates critical installation, configuration, or operation information. Failure to comply with this information may render the product partially or completely inoperative, damage third-party equipment, or cause harm to the user.



The term “DMX” used throughout this document refers to the USITT DMX512-A transmission protocol.

What is in the Box

- One Ilumiline 21 IP Optic
- Warranty Card
- Quick Reference Guide

Unpacking Instructions

Immediately upon receiving a product from ILUMINARC®, carefully unpack the carton. Check the contents of the box to ensure that all parts are present and that they are in good condition. If any part appears damaged from shipping, or if the carton shows signs of mishandling, see the *Claims* section in the *Technical Information* chapter.

Text Conventions

Convention	Meaning
1~512	A range of values in the text
50/60	A set of mutually exclusive values in the text
“ILUMICON UM”	The name of another publication or manual
<SET>	A button on the product’s control panel
Settings	A product function or a menu option
MENU > Settings	A sequence of menu options
1~10	A range of menu values from which to choose in a menu
Yes/No	A set of two mutually exclusive menu options in a menu
ON	A unique value to enter or select in a menu



There are no user serviceable parts inside this product. Any reference to servicing you may find from now on in this User Manual will only apply to properly ILUMINARC® certified technicians. Do not open the housing or attempt any repairs unless you are one of them.



Please refer to all applicable local codes and regulations for the proper installation of this product.



Keep this manual for future consultation. If you sell this product to another user, make sure that they also receive this manual.



In the unlikely event that your Illumiline 21 IP Optic Series may require service, please contact ILUMINARC® Technical Support.

Safety Notes

Please read all the following safety notes carefully because they include important information on how to install, use, and maintain this product safely.

Personal Safety

- Avoid direct eye exposure to the light source while the product is on.
- Always disconnect this product from its power source before servicing.
- Always connect this product to a grounded circuit to avoid the risk of electrocution.
- Do not touch this product's housing when operating because it may be very hot.

Mounting and Installation

- This product is for outdoor use and it can be submerged (IP67). However, do not submerge deeper than 1 m for more than 30 min.
- Make sure there are no flammable materials close to this product while operating.
- When hanging this product, always secure it to a fastening device using a safety cable (not provided).

Power and Wiring

- Always make sure that you are connecting this product to the proper voltage, as per the specifications in this manual or on the product's sticker.
- Never connect this product to a dimmer pack.
- Make sure that the power input cable is not cracked, crimped, or damaged.

Operation

- The maximum ambient temperature (Ta) is 104° F (40° C). Do not operate this product at a higher temperature.
- In case of a serious operating problem, stop using this product immediately!

2. Product Description

The Ilumiline 21 IP Optic Series encompasses two products, Ilumiline 21 IP Optic RGB, and the Ilumiline 21 IP Optic VW. Each of these series of products is available in 25 x 6, 15, and 30 degree optics.

Common Features

- Remotely addressable DMX-512 LED wash light
- IP67 ingress protection
- IP67 with 316 stainless steel gland nuts for cable entry
- Cast aluminum housing
- High Power 1 W (350mA) LEDs
- Ilumicode compatible
- ILUMICON compatible



Other than their LED configuration and programming features, these

two products share the same dimensions, as well as the installation, wiring, and troubleshooting procedures.

Ilumiline 21 IP Optic RGB Features

- Operating modes:
 - 1-channel: Dimmer
 - 3-channel: RGB control
 - 4-channel: RGB, dimmer
 - 7-channel: RGB, dimmer, macro, strobe, dimming speed

Ilumiline 21 IP Optic SpectraWhite™ Features

- Operating modes:
 - 1-channel: Dimmer
 - 2-channel: Warm white, cool white
 - 3-channel: Warm white, cool white, dimmer
- Installed (non-changeable) optical system:
- Blackout/static/dimmer/strobe/pulse
- Installed (non-changeable) optical system



The lenses in these two products are non-changeable.

Therefore, make sure to use the right product order code for the desired lens angle.

Additional Features

- Five distinct dimming curves

Product Dimensions

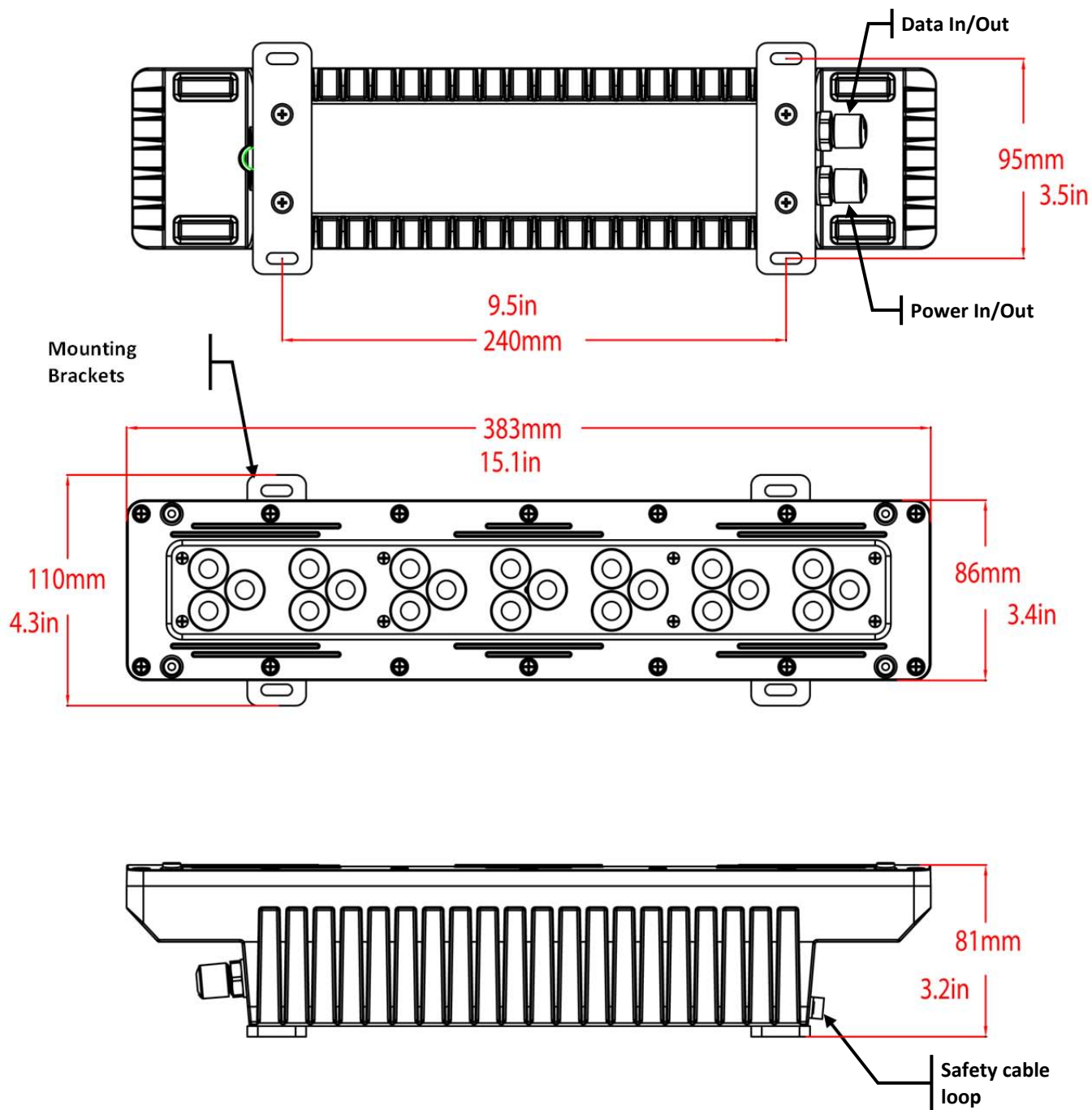

3. Installation



Always connect the Ilumiline 21 IP Optic Series to a protected circuit with an appropriate electrical ground to avoid the risk of electrocution or fire.



Never connect the Ilumiline 21 IP Optic Series to a rheostat (variable resistor) or dimmer circuit, even if the rheostat or dimmer channel serves only as a 0 to 100% switch.



Make sure to connect the Ilumiline 21 IP Optic Series product to a power line with the proper voltage and frequency, as per the specifications in this manual or on the product's sticker.



The listed current rating indicates the maximum current draw during normal operation.

AC Power

Input Voltage and Frequency

The products in the Ilumiline 21 IP Optic Series have an auto-ranging power supply with an input voltage range of 100~240 VAC, 50/60 Hz.

Power Consumption

To determine the power requirements for any of the Ilumiline 21 IP Optic Series, see the label affixed to the side of the product. Alternatively, you may refer to the corresponding specifications chart in the *Technical Information* chapter of this manual.

Power Wiring

To provide AC power for any of the Ilumiline 21 IP Optic Series, you can connect the bare-ended IP67 rated power cable from the product to an IP67 rated power connector or use an IP67 rated junction box. In this case, make sure to use IP67 rated conduit or direct buried cable (DBC)

Connection	Wire (US)	Wire (Europe)
Live	Black	Brown
Neutral	White	Blue
Ground	Green/Yellow	Green/Yellow

AC Power Input Wiring

Signal Wiring

To provide signal for any of the Ilumiline 21 IP Optic Series, you can connect the bare-ended IP67 rated signal cable from the product to two IP67 rated signal connectors (DMX in and DMX Out) or use an IP67 rated junction box. In this case, make sure to use IP67 rated conduit or direct buried cable (DBC).



The signal cable must match or exceed the electrical

characteristics of the Belden® 9841 cable for EIA RS-485 applications.



If you choose to bury the power or signal distribution boxes, make sure that they are IP67 rated.



Always keep the power cables away from the signal cables by running them in different conduits and using separate distribution boxes.



Make sure to use power and signal cables with the indicated outer diameters to ensure that the corresponding gland nut makes full contact with the cable's external insulation. This is required to keep the product's IP67 rating when fully adjusted.

External Wiring

You must run AC power and signal wires from the respective AC and signal distribution boxes into each of the Illumiline 21 IP Optic Series.

Power Distribution

Connect the bare-ended power cable from the product to a power distribution box as indicated below.

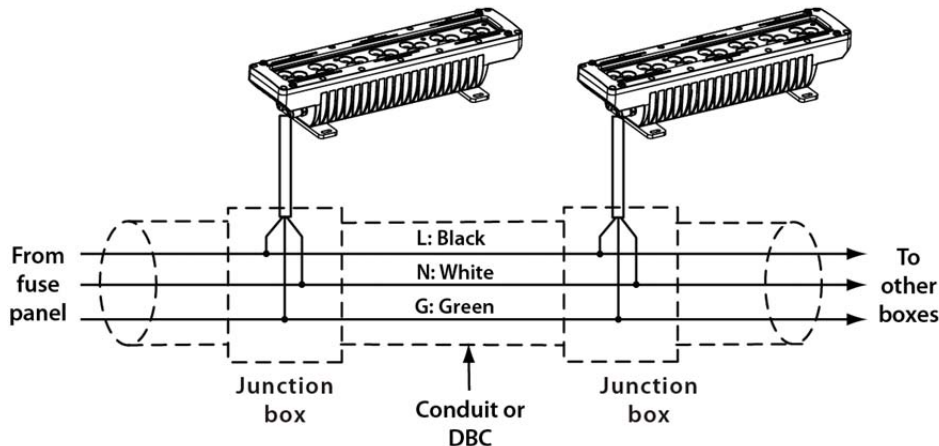

Signal Distribution

Connect the bare-ended signal cable from the product to a signal distribution box as indicated below.

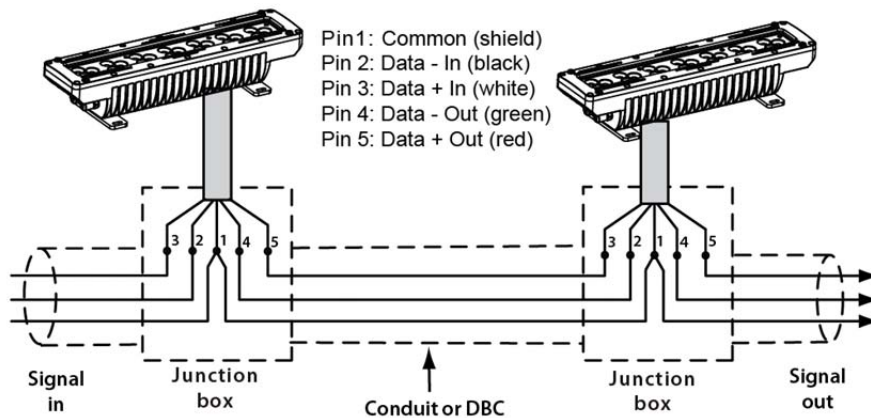

Controllers



If you have not configured the DMX starting address and DMX mode for each product they will all use their default values. This means that all products will operate in unison.



Refer to the Operation chapter to learn how to enable the Ilumiline 21 IP Optic Series to operate with the ILUMICON controller.



To assign individual DMX addresses to each product you must connect the Ilumicode controller to each product individually.



ILUMINARC® suggests that you connect no more than 20 products in this mode and keep the total distance to less than 60 m (197 ft). Otherwise, you might need to use an optically isolated signal amplifier.

The products in the Ilumiline 21 IP Optic Series can operate with a standard DMX controller, the ILUMICON controller, or the Ilumicode controller. The sections below will show you how to connect these products to the corresponding controllers. The instructions to operate these products with each of the above controllers are in the *Operation* chapter of this manual.

DMX Controller

The Ilumiline 21 IP Optic Series can work with a standard DMX controller. The channel assignments will depend on the chosen personality (see the corresponding *Menu Map* on pages 10 and 11), and the DMX address assigned to each product (see *Programming* on page 12).

The figure below illustrates how to connect the DMX controller to the Ilumiline 21 IP Optic Series.

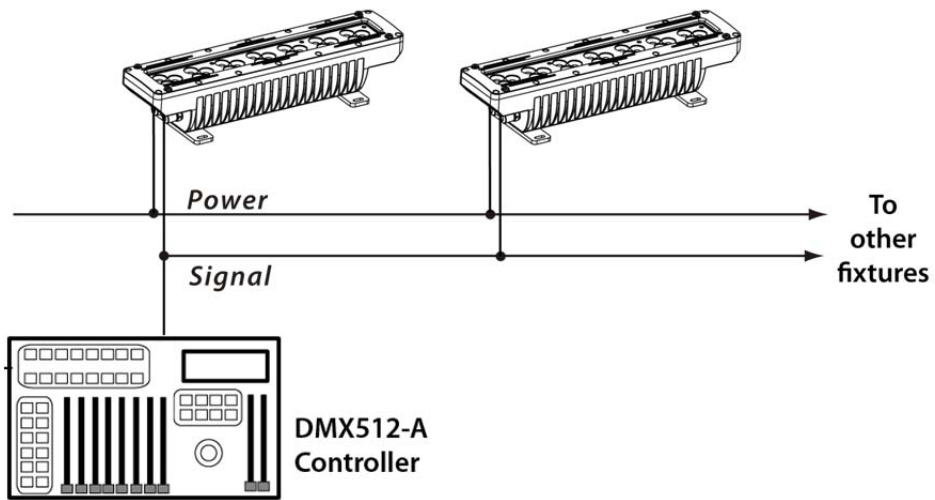

ILUMICON

The Ilumiline 21 IP Optic Series can also work with the ILUMICON controller instead of a standard DMX controller. Please refer to the ILUMICON User Manual to learn how to use this controller with the Ilumiline 21 IP Optic Series.

The figure below illustrates how to connect the ILUMICON controller to the Ilumiline 21 IP Optic Series.

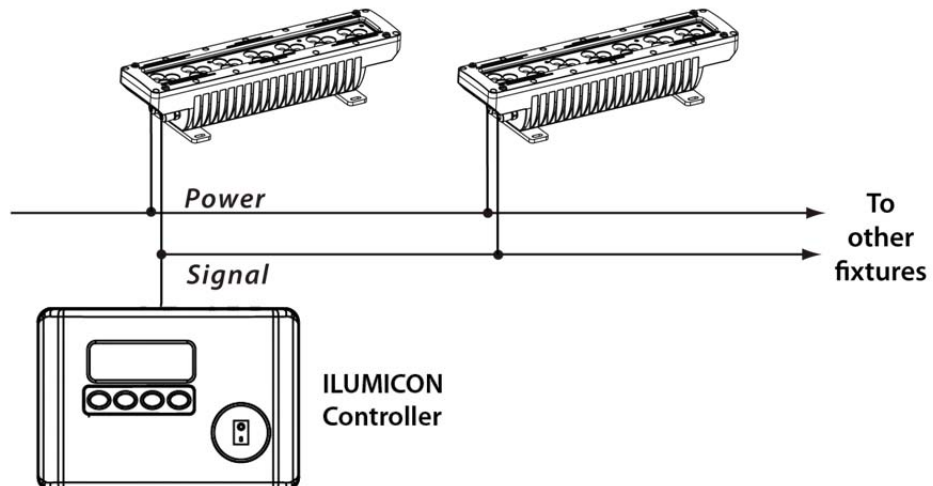

Ilumicode

The diagram below shows how to connect the Ilumicode to this product.

Note that this connection will control multiple products at the same time, all having the same DMX address.

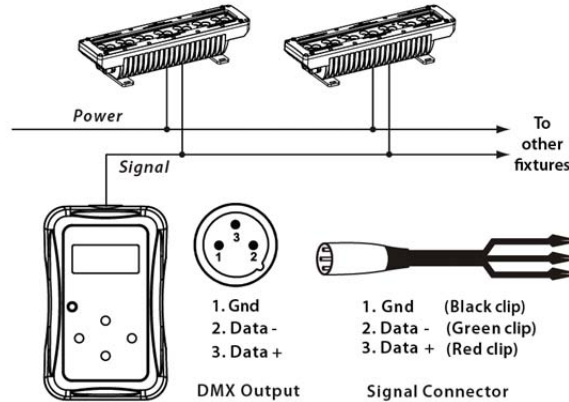

Mounting

Before mounting these products read and follow the safety recommendations indicated in the Safety Notes section (page 2 of this manual).

Orientation

Always mount this product in any safe position while making sure that there is adequate room around it for ventilation, configuration, and maintenance.

Rigging

The Ilumiline 21 IP Optic Series consists of a cast aluminum mounting bracket with 4 screw holes. ILUMINARC® recommends following the general guidelines below when mounting the Ilumiline 21 IP Optic Series.

- When selecting an installation location, consider ease of access to the product for operation, programming adjustments and routine maintenance.
- Make sure that the location where you are mounting the product can support its weight. Please see the *Technical Specifications* section of this manual for the weight requirement of this fixture.

Procedure

The Ilumiline 21 IP Optic Series comes with cast aluminum mounting brackets which you can use to attach to a flat mounting surface. These brackets also serve as floor or wall mount supports. You will have to use four mounting points per fixture.

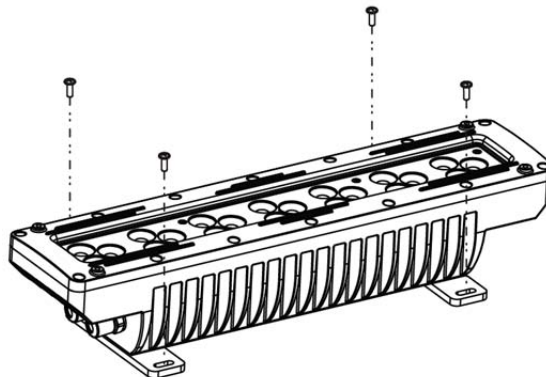

 *Make sure to mount this product away from any flammable material as indicated in the Safety Notes.*

4. Operation

Ilumicode

The products in the Ilumiline 21 IP Optic Series lack a control panel. Therefore, they need an external controller, the Ilumicode device, to change their configuration.

Ilumicode Panel Description

Button	Function
<MENU>	Exits from the current menu or function
<ENTER>	Enables the currently displayed menu or sets the currently selected value into the selected function
<UP>	Navigates upwards through the menu list and increases the numeric value when in a function
<DOWN>	Navigates downwards through the menu list and decreases the numeric value when in a function
<POWER>	Turns the unit on. The unit will turn off automatically after 30 seconds of inactivity.

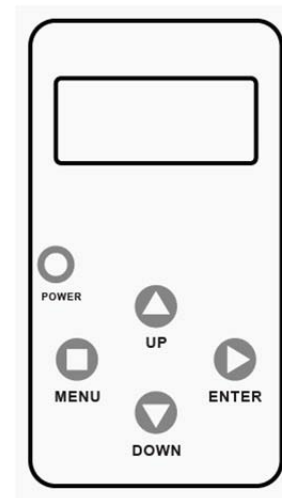

When you scroll through the menu options, you will see

many of them that do not correspond with this menu map. Skip them, as they do not work with the White output products.

Menu Map

The products in the Ilumiline 21 IP Optic Series have distinct menu maps based on the colors they produce, whether RGB or White. The Ilumicode controller presents the functions for both types of products.

White Functions Menu Map

This menu map shows you which parameters of the Ilumicode controller correspond to the Ilumiline 21 IP Optic VW product.



If you scroll after STRB, you will see the RED, GREN, BLUE,

and AMBE colors. Just skip them as they do not work with the VW products.

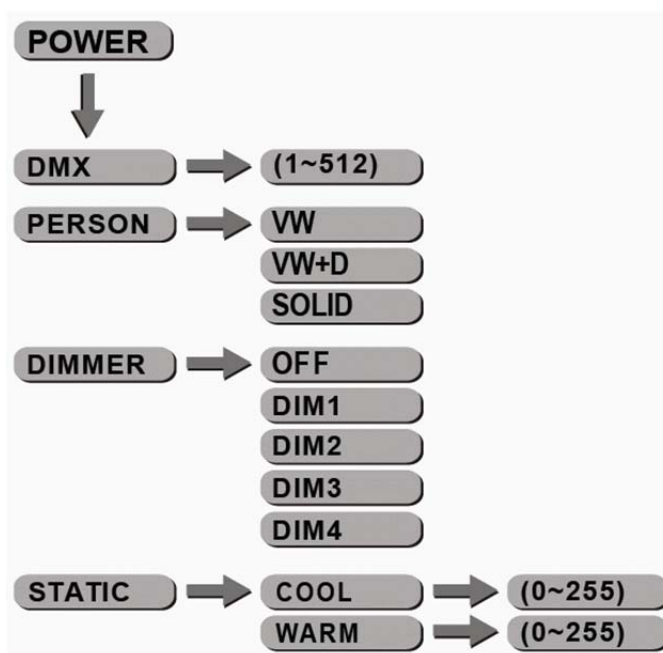

RGB Functions Menu Map

This menu map shows you which parameters of the Ilumicode controller correspond to the Ilumiline 21 IP Optic RGB product.



When you scroll through the menu options, you will see many of them that do not correspond with this menu map. Skip them, as they do not work with the RGB only output products.



If you scroll after STRB, you will see the AMBE, COOL, and WARM colors. Just skip them as they do not work with the RGB products.

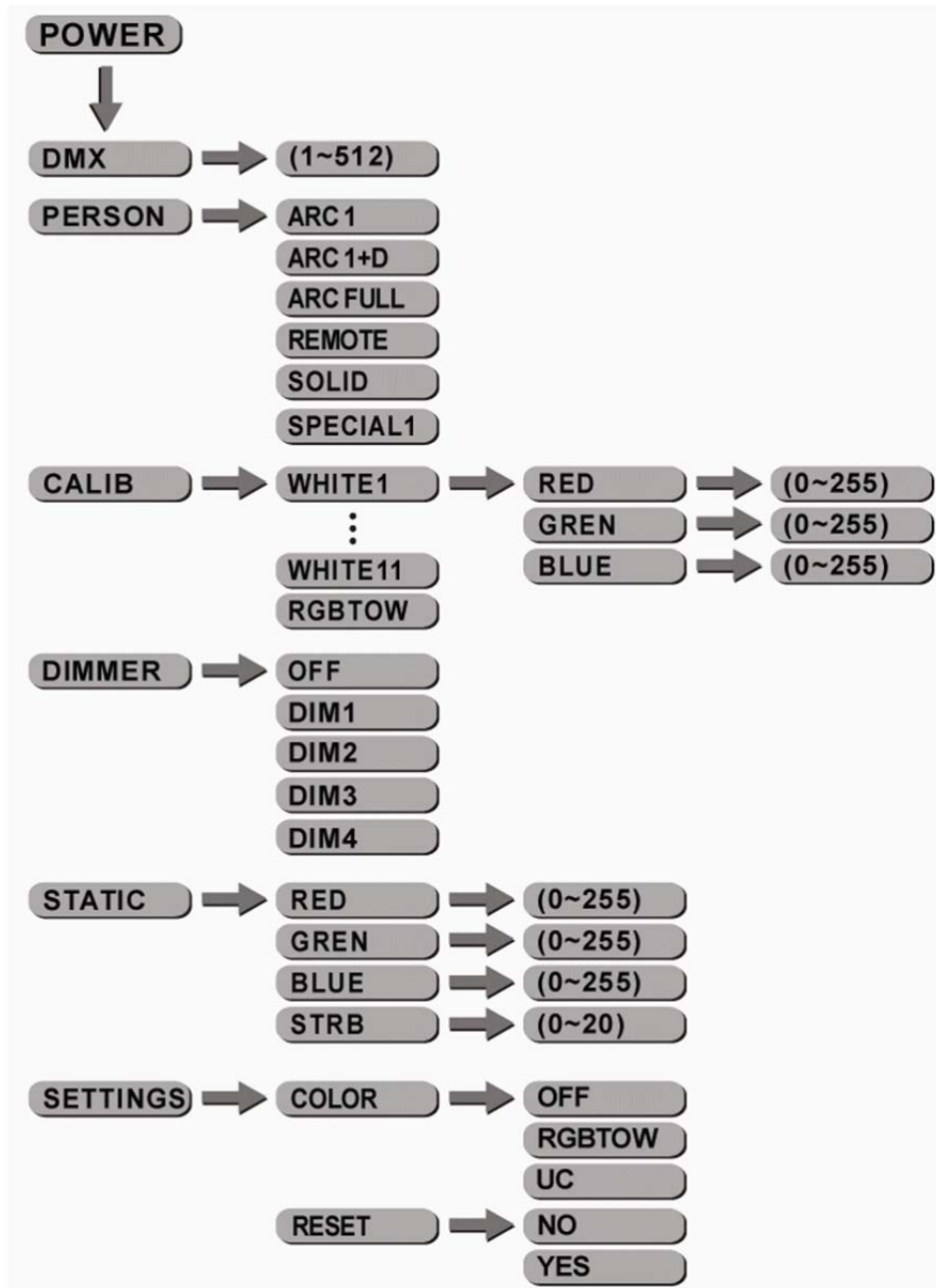

Programming



Make sure to press **<ENTER>** after selecting an option. Otherwise, the product will not save the new setting. In this case, the Ilumicode's display will show "SEND..."

Carry out all the programming procedures indicated below from the control panel. Refer to the *Menu Map* in pages 10 and 11 to learn how the menu options relate to each other.

Use **<ENTER>** and **<MENU>** to change levels in the *Menu Map*. This is equivalent to move right and left respectively. Use **<UP>** and **<DOWN>** to move vertically within the *Menu Map* options.

DMX Personality

1. Go to **PERSON** and select any DMX personality that matches the product with which you are working (ignore any other options).

21 IP RGB	21 IP VW
ARC1	
ARC+D	
ARC FULL	
SOLID	SOLID
	VW
	VW+D

2. Make sure to rearrange the DMX addresses of all products in the current DMX universe to avoid address overlapping.

DMX Starting Address

(All Ilumiline 21 IP Optic Series)



The DMX Starting Address setting works with all but the **REMOTE** personality.

1. Go to **DMX**.
2. Select a starting DMX address (**001~512**).

Dimmer

(All Ilumiline 21 IP Optic Series)

1. Go to **DIMMER**.
2. Select a dimmer curve (**OFF** or **DIM1~4**).

DIMMER	Description
OFF	Dimmer curve is linear with fader
DIM1	Non-linear (fastest)
DIM2	Non-linear (fast)
DIM3	Non-linear (slow)
DIM4	Non-linear (slowest)



Do not connect any other controller to the fixture(s) when using the ILUMICON controller.

ILUMICON Control

(Only for Ilumiline 21 IP Optic RGB)

1. Go to **PERSON**.
2. Select the **REMOTE** personality.

Static Color

(Only for Ilumiline 21 IP Optic RGB)

1. Go to **STATIC**.
2. Select a color (**RED**, **GREEN**, or **BLUE**).
3. Select a color value (**000~255**).
4. Select **STRB**.
5. Select a strobe frequency (**0~20**).

(Only for Ilumiline 21 IP Optic VW)

1. Go to **STATIC**.
2. Select a color (**COOL** or **WARM**).
3. Select a color value (**000~255**).

Color Calibration

(Only for Ilumiline 21 IP Optic RGB)

1. Go to **CALIB**
2. Select a white color (**WHITE 1~11**) or **RGBTOW**.
3. Select an RGB color (**RED**, **GREEN**, or **BLUE**).
4. Select a color value (**0~255**).
5. Repeat steps **3** and **4** for the other RGB colors to obtain a white color.
6. Repeat steps **2** to **5** for the other white colors.

WHITE 1~11 define the white color shown when selecting a value **201~255** in channel **5** for the **ARC FULL** personality.

RGBTOW defines the white color shown when the **COLOR** value is set to **RGBTOW**.

Color

(Only for Ilumiline 21 IP Optic RGB)

1. Go to **SETTINGS > COLOR**.
2. Select the color method (**OFF**, **RGBTOW**, or **UC**).

Color	Description
OFF	When the RGB faders are all at “ 255 ”, the output is at its maximum.
RGBTOW	When the RGB faders are all at “ 255 ”, the output is the selected white color (see <i>Color Calibration</i>).
UC	When the RGB faders are all at “ 255 ”, the output matches the same color output of previous versions of this fixture.

Reset

(Only for Ilumiline 21 IP Optic RGB)

1. Go to **SETTINGS > RESET TO FACTORY SETTINGS**.
2. Select an option (**YES/NO**).

DMX Values

ARC 1

Channel	Function	Value	Percent/Setting
1	Red	000 ⇔ 255	0 ~ 100%
2	Green	000 ⇔ 255	0 ~ 100%
3	Blue	000 ⇔ 255	0 ~ 100%

ARC 1 + D

Channel	Function	Value	Percent/Setting
1	Dimmer	000 ⇔ 255	0 ~ 100%
2	Red	000 ⇔ 255	0 ~ 100%
3	Green	000 ⇔ 255	0 ~ 100%
4	Blue	000 ⇔ 255	0 ~ 100%

ARC FULL

Channel	Function	Value	Percent/Setting
1	Dimmer	000 ⇔ 255	0 ~ 100%
2	Red	000 ⇔ 255	0 ~ 100%
3	Green	000 ⇔ 255	0 ~ 100%
4	Blue	000 ⇔ 255	0 ~ 100%
5	Color Macro + White Balance	000 ⇔ 010	No Function
		011 ⇔ 030	Red 100% - Green Up - Blue 0%
		031 ⇔ 050	Red Down - Green 100% - Blue 0%
		051 ⇔ 070	Red 0% - Green 100% - Blue Up
		071 ⇔ 090	Red 0% - Green Down - Blue 100%
		091 ⇔ 110	Red Up - Green 0% - Blue 100%
		111 ⇔ 130	Red 100% - Green 0% - Blue Down
		131 ⇔ 150	Red 100% - Green Up - Blue Up
		151 ⇔ 170	Red Down - Green Down - Blue 100%
		171 ⇔ 200	Red 100% - Green 100% - Blue 100%
		201 ⇔ 205	White 1: 3,200 K
		206 ⇔ 210	White 2: 3,400 K
		211 ⇔ 215	White 3: 4,200 K
		216 ⇔ 220	White 4: 4,900 K
221 ⇔ 225	White 5: 5,600 K		
226 ⇔ 230	White 6: 5,900 K		
231 ⇔ 235	White 7: 6,500 K		
236 ⇔ 240	White 8: 7,200 K		
241 ⇔ 245	White 9: 8,000 K		
246 ⇔ 250	White 10: 8,500 K		
251 ⇔ 255	White 11: 10,000 K		
6	Strobe	000 ⇔ 004	No Function
		005 ⇔ 255	0 ~ 20 Hz
7	Dimming Speed	000 ⇔ 009	Dimmer is set by Ilumicode
		010 ⇔ 029	OFF (Dimmer is linear)
		030 ⇔ 069	DIM1 (Fastest dimmer curve)
		070 ⇔ 129	DIM2
		130 ⇔ 189	DIM3
		190 ⇔ 255	DIM4 (Slowest dimmer curve)

VW

Channel	Function	Value	Percent/Setting
1	Warm White	000 ⇔ 255	0 ~ 100%
2	Cool White	000 ⇔ 255	0 ~ 100%

VW + D

Channel	Function	Value	Percent/Setting
1	Dimmer	000 ⇔ 255	0 ~ 100%
2	Warm White	000 ⇔ 255	0 ~ 100%
3	Cool White	000 ⇔ 255	0 ~ 100%

SOLID

Channel	Function	Value	Percent/Setting
1	Dimmer	000 ⇔ 255	0 ~ 100%

5. Technical Information

Product Maintenance

To maintain optimum performance and minimize wear, the user should clean the products frequently. Usage and environment are contributing factors in determining the cleaning frequency. As a rule, the user should clean the products at least twice a month. Dust build up reduces light output performance and can cause overheating. This can lead to reduced light source life.

For products containing external optical lenses, the user should clean them periodically to optimize light output. The cleaning frequency depends on the environment in which the product operates. Damp, smoky, or particularly dirty surroundings can cause greater accumulation of dirt on the unit's optics.

To clean a product follow the below recommendations:

- Unplug the product from power.
- Wait until the product is cold.
- Use a vacuum (or dry compressed air) and a soft brush to remove dust collected on the external vents and reachable internal components.
- Clean all external glass optics and glass surfaces with a mild solution of glass cleaner or isopropyl alcohol, and a soft, lint free cotton cloth or a lens cleaning tissue.
- Apply the solution directly to the cloth or tissue and drag any dirt and grime to the outside of the lens.
- Gently polish the external glass surfaces until they are free of haze and lint.



Always dry the external optics and glass surfaces carefully after cleaning them.



If you still experience technical problems after trying the solutions in the Troubleshooting Table, contact ILUMINARC® Technical Support.

Product Repairs

ILUMINARC® strongly advises you against attempting any repairs to this product unless you are an authorized ILUMINARC® technician.

ILUMINARC® presents the information contained in the Troubleshooting Table as a guide only. In most cases, opening the product's housing will invalidate its warranty, unless there is a written indication to the contrary.

Troubleshooting Guide

Symptom	Cause(s)	Action(s)
Product does not light up	Dimmer fader set to “0”	Increase the value of the dimmer channel
	All color faders set to “0”	Increase the value of the color channels
	All colors in STATIC are set to “0”	Increase the values of the colors
	Unit is being configured with Ilumicode	Complete the configuration process.
	No power	Verify external power circuit and wiring
	Faulty internal power supply	Change power supply
	Faulty main control board	Change main control board
One LEDs does not work	Faulty LED	Change LED module
	Faulty LED module	
	Faulty LED driver	Change LED driver
The wrong LEDs light up when using DMX	Wrong personality	Change the personality
	Wrong DMX address	Change the DMX address
Circuit breaker/fuse keeps tripping/blowing	Excessive circuit load	Check total load on electrical circuit
	Short circuit along the power wires	Check for a short in the electrical wiring
Product does not respond to DMX	Wrong DMX addressing	Change DMX address
	Damaged DMX cables	Check DMX cables
	Wrong polarity on the controller	Check polarity switch settings on the controller
	Loose DMX cables	Check cable connections
	Faulty DMX interface	Replace the main control board
	Faulty Display/Main board	
DMX signal problems	Non DMX cables	Use only DMX compatible cables
	Unstable control signals	Install terminator as suggested
	Long cable / low level signal	Install an optically coupled DMX splitter right after the product with the strong signal
	Too many products	Install an optically coupled DMX splitter after unit #32 or before
	Interference from AC wires	Keep DMX cables separated from power cables or fluorescent/black lights

Photometrics

**Filename: Ilumiline 21IP Optic 15 RGB-
 RGB_IESNA2002**
 Manufacturer: ILUMINARC
 Luminaire: ILUMILINE 21IP OPTIC RGB 15
 DEGREE
 Luminaire Cat: 12021002
 Lamp: 7 RED, 7 GREEN, 7 BLUE
 Lamp Output: 1 lamp(s), rated Lumens/lamp: 800
 Max Candela: 10,449.6 at Horizontal: 0°, Vertical: 0°
 Input Wattage: 30.5
 Luminous Opening: Point
 Test: 2008102203
 Test Lab: Iluminarc R&D Optics Laboratory
 Photometry : Type B
 CIE Class: Direct
 Cutoff Class: Full Cutoff

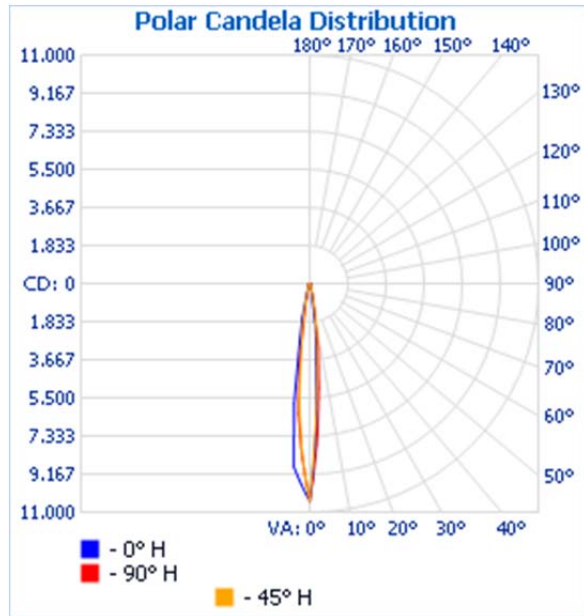

Flood Summary

	Efficiency	Lumens	Horizontal Spread	Vertical Spread
Field (10%):	55.9%	446.8	23	23.4
Beam (50%):	24.6%	196.7	10.9	11.7
Total:	68.3%	654.8		

Distance	Illuminance at a Distance	
	Center Beam FC	Beam Width
3.0ft	1,161.06 fc	0.6ft 0.6ft
6.0ft	290.27 fc	1.2ft 1.1ft
9.0ft	129.01 fc	1.8ft 1.7ft
12.0ft	72.57 fc	2.5ft 2.3ft
15.0ft	46.44 fc	3.1ft 2.9ft
18.0ft	32.25 fc	3.7ft 3.4ft

■ Vert. Spread: 11.7° ■ Horiz. Spread: 10.9°

Photometrics Pro 1.3.2 copyright 2003-2008 by jSolutions, Inc.
 Reported data calculated from manufacturer's data file, based on IES recommended methods.

**Filename: Ilumiline 21IP Optic 30 RGB-
RGB_IESNA2002**

Manufacturer: ILUMINARC

Luminaire: ILUMILINE 21IP OPTIC RGB 30
DEGREE

Luminaire Cat: 12021001

Lamp: 7 RED, 7 GREEN, 7 BLUE

Lamp Output: 1 lamp(s), rated Lumens/lamp: 800

Max Candela: 2,279 at Horizontal: 0°, Vertical: 0°

Input Wattage: 28.1

Luminous Opening: Point

Test: 2009430RGB

Test Lab: Iluminarc R&D Optics Laboratory

Photometry : Type B

CIE Class: Direct

Cutoff Class: Full Cutoff

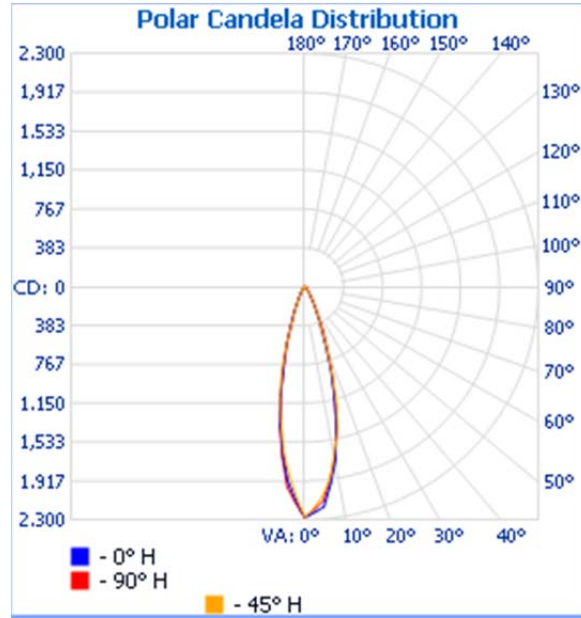

Flood Summary

	Efficiency	Lumens	Horizontal Spread	Vertical Spread
Field (10%):	62.3%	514.5	50.8	49.7
Beam (50%):	33.7%	279.6	27.2	27
Total:	74.6%	616.1		

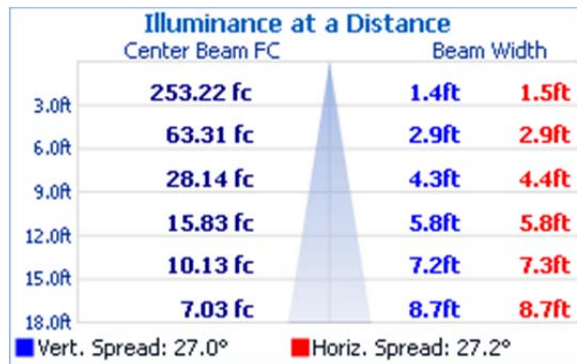

Photometrics Pro 1.3.2 copyright 2003-2008 by jSolutions, Inc.
Reported data calculated from manufacturer's data file, based on IES recommended methods.

Filename: Ilumiline 21IP Optic 25x6 RGB-
RGB_IESNA2002

Manufacturer: ILUMINARC

Luminaire: ILUMILINE 21IP OPTIC RGB 25x6
DEGREE

Luminaire Cat: 12021003

Lamp: 7 RED, 7 GREEN, 7 BLUE

Lamp Output: 1 lamp(s), rated Lumens/lamp: 826

Max Candela: 2,163.5 at Horizontal: 310, Vertical: 7.5

Input Wattage: 24.5

Luminous Opening: Point

Test: 2009430RGB

Test Lab: Iluminarc R&D Optics Laboratory

Photometry : Type B

CIE Class: Direct

Cutoff Class: Full Cutoff

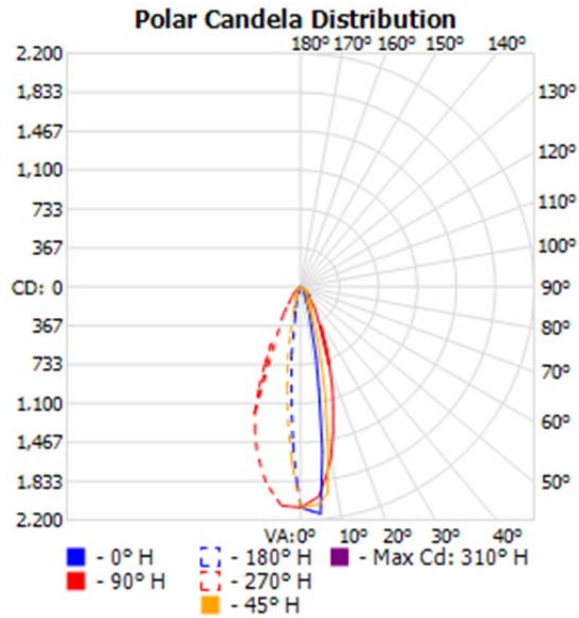

Flood Summary

	Efficiency	Lumens	Horizontal Spread	Vertical Spread
Field (10%):	47.9%	395.7	63.5	31.8
Beam (50%):	26%	214.7	38.9	14.2
Total:	68.3%	564.3		

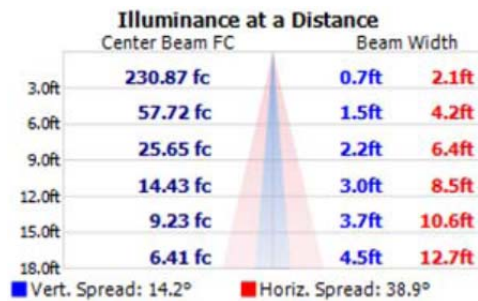

Photometrics Pro 1.3.2 copyright 2003-2008 by jSolutions, Inc.
Reported data calculated from manufacturer's data file, based on IES recommended methods.

Filename: Ilumiline 21 IP Optic 15 VW 100% ALL
 Manufacturer: ILUMINARC
 Luminaire: Ilumiline 21 IP Optic 15VW
 Lamp: 14 Warm White, 7 Cool White
 Lamp Output: 1 lamp(s), rated Lumens/lamp: 1400
 Max Candela: 5,853.3 at Horizontal: 0°, Vertical: 0°
 Input Wattage: 29.1
 Luminous Opening: Point
 Test: 2009 ALL
 Test Lab: Iluminarc R & D Optics Laboratory
 Photometry : Type B
 CIE Class: Direct
 Cutoff Class: Full Cutoff
Filename: Ilumiline 21 IP Optic 15 VW 100% ALL

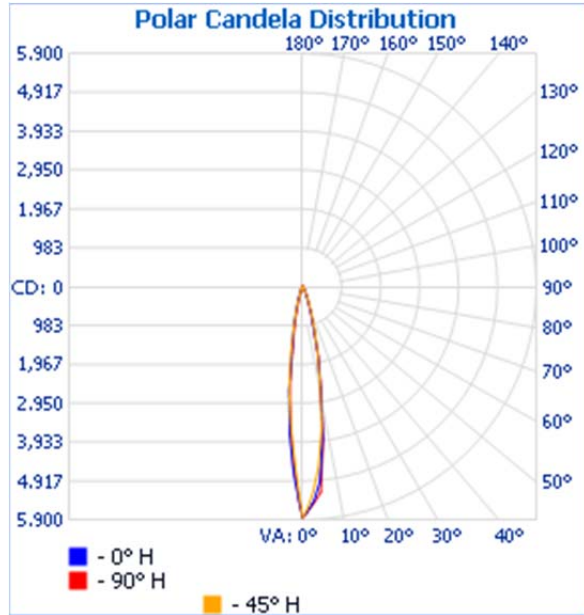

Flood Summary

	Efficiency	Lumens	Horizontal Spread	Vertical Spread
Field (10%):	36.5%	511.6	32.8	33.6
Beam (50%):	15.2%	213.4	15.9	16.2
Total:	49.5%	693.0		

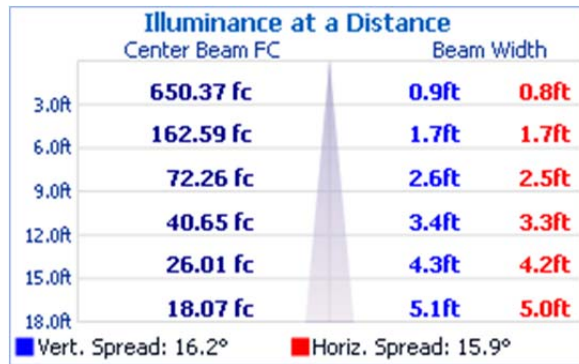

Photometrics Pro 1.3.2 copyright 2003-2008 by jSolutions, Inc.
 Reported data calculated from manufacturer's data file, based on IES recommended methods.

Filename: Ilumiline 21 IP Optic 30 VW 100% ALL
 Manufacturer: ILUMINARC
 Luminaire: Ilumiline 21 IP Optic 30 VW
 Lamp: 14 Warm White, 7 Cool White
 Lamp Output: 1 lamp(s), rated Lumens/lamp: 1400
 Max Candela: 2,036.6 at Horizontal: 0°, Vertical: 0°
 Input Wattage: 28.9
 Luminous Opening: Point
 Test: 2009 ALL
 Test Lab: Iluminarc R & D Optics Laboratory
 Photometry : Type B
 CIE Class: Direct
 Cutoff Class: Full Cutoff
Filename: Ilumiline 21 IP Optic 30 VW 100% ALL

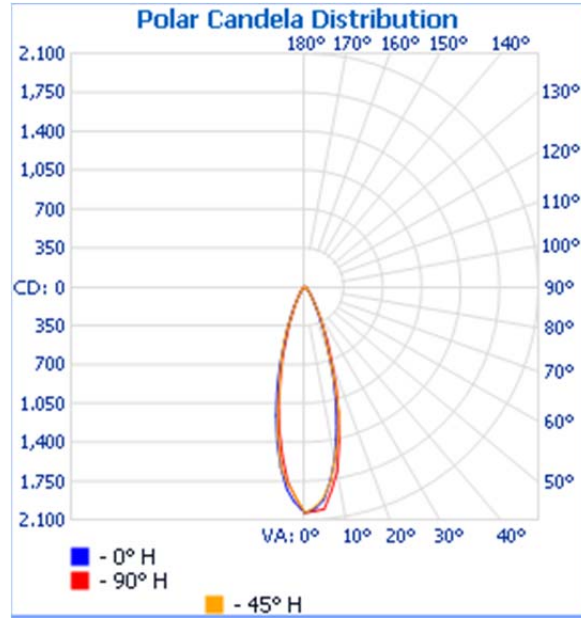

Flood Summary

	Efficiency	Lumens	Horizontal Spread	Vertical Spread
Field (10%):	41%	547.3	56.7	56.8
Beam (50%):	22.1%	309.1	29.8	30
Total:	48.8%	682.7		

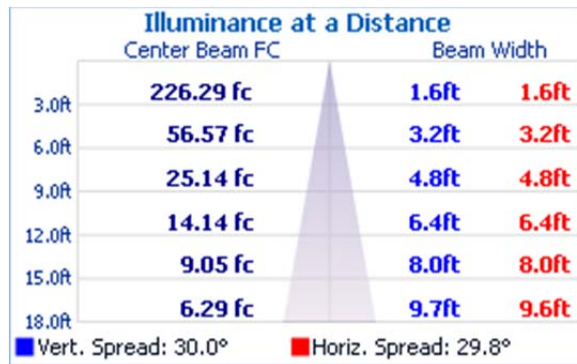

Photometrics Pro 1.3.2 copyright 2003-2008 by jSolutions, Inc.
 Reported data calculated from manufacturer's data file, based on IES recommended methods.

Filename: Ilumiline 21 IP Optic 25x6 VW 100% ALL

Manufacturer: ILUMINARC
 Luminaire: Ilumiline 21 IP Optic 25x6 VW
 Lamp: 14 Warm White, 7 Cool White
 Lamp Output: 1 lamp(s), rated Lumens/lamp: 1400
 Max Candela: 2,587.2 at Horizontal: 320, Vertical: 5
 Input Wattage: 29.9
 Luminous Opening: Point
 Test: 2009 ALL
 Test Lab: Iluminarc R & D Optics Laboratory
 Photometry : Type B
 CIE Class: Direct
 Cutoff Class: Full Cutoff

Filename: Ilumiline 21 IP Optic 25x6 VW 100% ALL

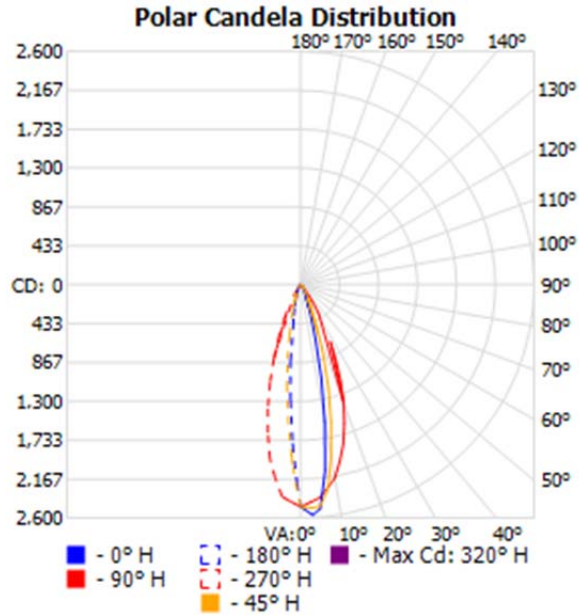

Flood Summary

	Efficiency	Lumens	Horizontal Spread	Vertical Spread
Field (10%):	36.7%	513.8	64	34.6
Beam (50%):	19.9%	278.0	38.2	16.2
Total:	46.4%	650.1		

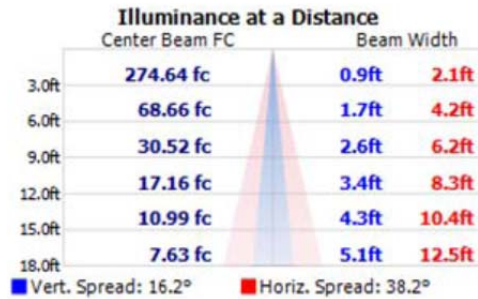

Photometrics Pro 1.3.2 copyright 2003-2008 by jSolutions, Inc.
 Reported data calculated from manufacturer's data file, based on IES recommended methods.

LED Disclaimer

LED Life

ILUMINARC® rates LED lifetime based on lumen depreciation of 70% of the original output, with data provided by the manufacturer of the LED. Data from the manufacturer of the LED are not independently verified or measured by ILUMINARC®. When the product is operating in optimal environmental conditions, the LED lifetime is rated to be 50,000 to 70,000 hours by the LED manufacturer.

LED Binning

LED manufacturers sort LEDs into “bins”, based on variances in color, output intensity and the frequency at which the semiconductor operates. ILUMINARC® strives to hold its LED manufacturers to the highest standards of binning to optimize consistency in output from product to product. However, the availability of a single bin cannot be guaranteed. With that in mind, ILUMINARC® has developed a rigorous control system to seek the best achievable consistency in color and output.

Color Rendering Index (CRI)

CRI is an industry standard method to compare properties of different types of light sources. There are known limitations and inconsistencies related to CRI. Results may vary depending on the environmental factors involved. For this reason, the US Department of Energy (DOE) states that CRI should be considered as one point of reference among others in evaluating white LED products and systems.

The following is an excerpt of recommendations from the DOE:

1. Identify the visual tasks to be performed under the light source. If color fidelity under different light sources is critically important (for example, in a space where color or fabric comparisons are made under both daylight and electric lighting), CRI values may be a useful metric for rating LED products.
2. CRI may be compared only for light sources of equal CCT. This applies to all light sources, not only to LEDs. Also, differences in CRI values of less than five points are not significant, e.g., light sources with 80 and 84 CRI are essentially the same.
3. If color appearance is more important than color fidelity, do not exclude white light LEDs solely on the basis of relatively low CRI values. Some LED products with CRIs as low as 25 still produce visually pleasing white light.
4. Evaluate LED systems in person and, if possible, on-site when color fidelity or color appearance are important issues.

Source: DOE publication: PNNL-SA-56891, January 2008

Returns Procedure

The user must send the merchandise prepaid, in the original box, with its original packing and accessories. ILUMINARC® will not issue call tags.

Call ILUMINARC® and request a Return Merchandise Authorization Number (RMA #) before shipping the product. Be prepared to provide the model number, serial number, and a brief description of the cause for the return.

The user must clearly label the package with a Return Merchandise Authorization Number (RMA #). ILUMINARC® will refuse any product returned without an RMA #.

Once you receive the RMA #, please include the following information on a piece of paper inside the box:

- Your name
- Your address
- Your phone number
- The RMA #
- A brief description of the problem

Be sure to pack the product properly. Any shipping damage resulting from inadequate packaging will be the customer's responsibility. As a suggestion, proper UPS packing or double-boxing is always a safe method to use.



DO NOT write the RMA # directly on the box. Instead,

write it on a properly affixed label.



ILUMINARC® reserves the right to use its own discretion to

repair or replace returned product(s).

Claims

The carrier is responsible for any damage incurred during shipping. Therefore, if the received merchandise appears to have damages caused during shipping, the customer must submit the damage report and any related claims with the carrier, not ILUMINARC®. The customer must submit the report upon reception of the damaged merchandise. Failure to do so in a timely manner may invalidate the customer's claim with the carrier.

For other issues such as missing components or parts, damage not related to shipping, or concealed damage, the customer must make claims to ILUMINARC® within seven (7) days of receiving the merchandise.



Always keep the original box and all packaging material as you

will need those to ship the unit back to ILUMINARC®

Contact Us

World Wide

General Information

ILUMINARC®
 5200 NW 108th Avenue
 Sunrise, FL 33351
 Voice: (954) 923-3680
 Fax: (954) 929-5571
 Email: info@iluminarc.com

Customer Support

Voice: (954) 923-3680 (ext. 4000)
 Fax: (954) 756-8015
 Email: tech@iluminarc.com

World Wide Web

www.iluminarc.com

Technical Specifications

Ilumiline 21 IP Optic RGB

<i>Dimensions and Weight</i>	Length	Width	Height	Weight
	15 in (383 mm)	4.3 in (110 mm)	3.3 in (82 mm)	6.60 lbs (3.0 kg)

Note: Dimensions in inches rounded to the nearest decimal digit.

<i>Electrical</i>	Power Supply Type	Range	Voltage Selection
	Switching (internal)	100~240 V, 50/60 Hz	Auto-ranging

Parameter	120 V, 60 Hz	230 V, 50 Hz
Consumption	24.5 W (05b)	28 W (0.2 A)
Inrush current	0.3 A	0.3 A

Power I/O	Input	Output
Connectors	Open Wires	N/A
Cord plug	Open Wires	N/A

<i>Light Source</i>	Type	Power	Lifespan
	LED	1 W	50,000 hours

Color	Quantity	Current
Red	7	350 mA
Green	7	350 mA
Blue	7	350 mA

<i>Photo Optic</i>	Parameter	25x6° Optics	15° Optics	30° Optics °
	Illuminance @ 5 m	99 lux	500 lux	109 lux
	Beam angle	38.9° x 14.2°	11.3°	27.1°
	Field angle	63.5° x 31.8°	23.2°	50.25°

<i>Thermal</i>	Max. External Temperature	Cooling System
	104° F (40° C)	Convection

<i>DMX</i>	I/O Connectors	Connector Type	Channel Range
	Open Wires	Sockets	1,3,4, or 7

<i>Ordering</i>	Ilumiline 21 IP Optic 15 RGB	Ilumiline 21 IP Optic 30 RGB	Ilumiline 21 IP Optic 25 x 6 RGB
	12021002	12021001	12021003



Technical Specifications

Illumiline 21 IP Optic VW

Dimensions and Weight	Length	Width	Height	Weight
	15 in (383 mm)	4.3 in (110 mm)	3.3 in (82 mm)	6.60 lbs (3.0 kg)

Note: Dimensions in inches rounded to the nearest decimal digit.

Electrical	Power Supply Type	Range	Voltage Selection
	Switching (internal)	100~240 V, 50/60 Hz	Auto-ranging

Parameter	120 V, 60 Hz	230 V, 50 Hz
Consumption	30 W (05b)	28 W (0.2 A)
Inrush current	0.3 A	0.3 A

Power I/O	Input	Output
Connectors	Open Wires	N/A
Cord plug	Open Wires	N/A

Light Source	Type	Power	Lifespan
	LED	1 W	50,000 hours

Color	Quantity	Current
Cool White	7	350 mA
Warm White	14	350 mA

Photo Optic	Parameter	25x6° Optics	15° Optics °	30° Optics °
	Illuminance @ 5 m	118 lux	280 lux	98 lux
	Beam angle	38.2° x 16.2°	16.05°	29.9°
	Field angle	64° x 34.6°	33.2°	56.8°

Thermal	Max. External Temperature	Cooling System
	104° F (40° C)	Convection

DMX	I/O Connectors	Connector Type	Channel Range
	Open Wires	Sockets	1,2, or 3

Ordering	Illumiline 21 IP Optic 15 VW	Illumiline 21 IP Optic 30 VW	Illumiline 21 IP Optic 25 x 6 VW
	12021005	12021004	12021006



ILUMINARC®
 5200 NW 108th Avenue
 Sunrise, FL 33351 U.S.A.
 Tel.: (954) 923-3680
 www.iluminarc.com
 July 2011

ILUMINARC®