



TE400 Series
TE420B / TE420 / 412P
410P / 407P / 405P



User Manual



Digium, Inc.
445 Jan Davis Drive NW
Huntsville, AL 35806
United States
Main Number: 1.256.428.6000
Tech Support: 1.256.428.6161
U.S. Toll Free: 1.877.344.4861
Sales: 1.256.428.6262
www.digium.com
www.asterisk.org
www.asterisknow.org

© Digium, Inc. 2013
All rights reserved.

No part of this publication may be copied, distributed, transmitted, transcribed, stored in a retrieval system, or translated into any human or computer language without the prior written permission of Digium, Inc.

Digium, Inc. has made every effort to ensure that the instructions contained in this document are adequate and error free. The manufacturer will, if necessary, explain issues which may not be covered by this documentation. The manufacturer's liability for any errors in the documents is limited to the correction of errors and the aforementioned advisory services.

This document has been prepared for use by professional and properly trained personnel, and the customer assumes full responsibility when using it.

Adobe and Acrobat are registered trademarks, and Acrobat Reader is a trademark of Adobe Systems Incorporated.

Asterisk, Digium, Switchvox, and AsteriskNOW are registered trademarks and Asterisk Business Edition, AsteriskGUI, and Asterisk Appliance are trademarks of Digium, Inc.

Any other trademarks mentioned in the document are the property of their respective owners.

Compliance Information

Compliance information for this product is available at <http://www.digium.com/ccs-compliance>.

Introduction to TE400 Series Documentation

This manual is a user guide for Digium's TE400 Series cards. The Digium TE400 Series cards are a T1/E1 capable card series created for voice. The cards in this series are as follows:

Table 1: TE400 Series Cards

Model	Features	Type
TE420B	3.3 volt, 4 Ports, Echo Cancellation	PCI Express
TE420	3.3 volt, 4 Ports	PCI Express
TE412P	3.3 volt, 4 Ports, Echo Cancellation	PCI 2.2
TE410P	3.3 volt, 4 Ports	PCI 2.2
TE407P	5.0 volt, 4 Ports, Echo Cancellation	PCI 2.2
TE405P	5.0 volt, 4 Ports	PCI 2.2

Document Organization

The TE400 Series user's guide is organized in the following manner:

Chapter/ Appendix	Title	Description
1	Overview	Identifies the features of the card you received. This chapter covers applications and uses of the TE400 Series cards in the real world.
2	Card Installation	Provides instructions for installing the card in your PC, acquiring correct drivers, and checking device compatibility.
3	Configuration	Provides examples for configuring dial plan options.
4	Troubleshooting	Explains resolutions to common problems and frequently asked questions pertaining to card installation and usage.
A	Pin Assignments	Lists the connectors and pin assignments.
B	Specifications	Details card specifications.
C	Glossary and Acronyms	Defines terms related to this product.

Symbol Definitions



Caution statements indicate a condition where damage to the unit or its configuration could occur if operational procedures are not followed. To reduce the risk of damage or injury, follow all steps or procedures as instructed.



The ESD symbol indicates electrostatic sensitive devices. Observe precautions for handling devices. Wear a properly grounded electrostatic discharge (ESD) wrist strap while handling the device.



The Electrical Hazard Symbol indicates a possibility of electrical shock when operating this unit in certain situations. To reduce the risk of damage or injury, follow all steps or procedures as instructed.

Important Safety Instructions

User Cautions



Servicing.

Do not attempt to service this card unless specifically instructed to do so. Do not attempt to remove the card from your equipment while power is present. Refer servicing to qualified service personnel.



Water and Moisture.

Do not spill liquids on this unit. Do not operate this equipment in a wet environment.



Heat.

Do not operate or store this product near heat sources such as radiators, air ducts, areas subject to direct, intense sunlight, or other products that produce heat.



Static Electricity.

To reduce the risk of damaging the unit or your equipment, do not attempt to open the enclosure or gain access to areas where you are not instructed to do so. Refer servicing to qualified service personnel.

Save these instructions for future reference.

TABLE OF CONTENTS

Chapter 1

Overview	12
Echo-Cancellation	17
What is Asterisk®?	18
Asterisk as a Phone Switch (PBX)	18
Asterisk as a Gateway	18
Asterisk in the Call Center	19
Asterisk in the Network	19
Asterisk Everywhere	20

Chapter 2

Card Installation	21
Unpacking the Card	22
Shipment Inspection	22
Identifying Communication Ports	23
T1/E1 Selection	25
Identifying Multiple Cards	25
Connecting Timing Cables	26
Slot Compatibility	28
Hardware Installation	30
Software Installation	31
Installing Asterisk	37

Chapter 3

Configuration39
 Configuring Card Features40
 Configuring T1/E1 Lines43
 Testing Your Configuration51

Chapter 4
Troubleshooting52

Appendix A
Pin Assignments58

Appendix B
Specifications59

Appendix C
Glossary and Acronyms61

Figure 1: Sample Legacy Phone Application14

Figure 2: Sample Channel Bank Application15

Figure 3: Sample IP Phone Application16

Figure 4: TE405P Card23

Figure 5: TE420 Card24

Figure 6: T1/E1 Jumpers25

Figure 7: Ident Wheel26

Figure 8: Timing Ports Example27

Figure 9: Motherboard Slots28

Figure 10: Insert the Card30

Table 1:	TE400 Series Cards	4
Table 1:	Card Identifiers	34
Table A-1:	RJ45 Telco Port Connector	58
Table B-2:	Maximum Power Consumption	60

Chapter 1

Overview

The Digium TE400 Series cards are a T1/E1 capable card series created for voice. They support industry standard protocols, including Robbed Bit Signaling (also known as CAS or Channel Associated Signaling), CCS (Common Channel Signaling), E&M, and Primary Rate ISDN (PRI). The TE400 Series cards are capable of running in E1, T1, or J1 modes. They are also capable of DACSing channels from one span to another. The TE400 Series are ideal for connecting phones to a channel bank, connecting to your T1/E1 switch, or connecting to a legacy PBX.

This manual is for use with the TE420/TE420B PCI Express card, as well as the 5 volt TE405P/407P and the 3.3 volt TE410P/412P Quad T1/E1 PCI cards. These cards are identified collectively as the TE400 Series cards throughout this manual.

Designed to be fully compatible with existing software applications and integrate fully with the Asterisk platform, the TE400 Series cards allow many advanced call features.

Voice Modes:

- PRI CPE and PRI NET
 - NI1
 - NI2
 - EuroISDN
 - 4ESS (AT&T)
 - 5ESS (Lucent)
 - DMS100
 - Q.SIG

- E&M
 - Wink
 - Feature Group B
 - Feature Group D

- FXO and FXS
 - Ground Start
 - Loop Start
 - Loop Start with Disconnect Detect

The TE400 Series cards can be used to connect your Asterisk machine to the PSTN world, your channel bank, or even another PBX. This is accomplished via a T1/E1 interface. The cards allow Asterisk software to connect to your network, creating a professional telephony environment. Figure 2 shows an example of the card's primary application.

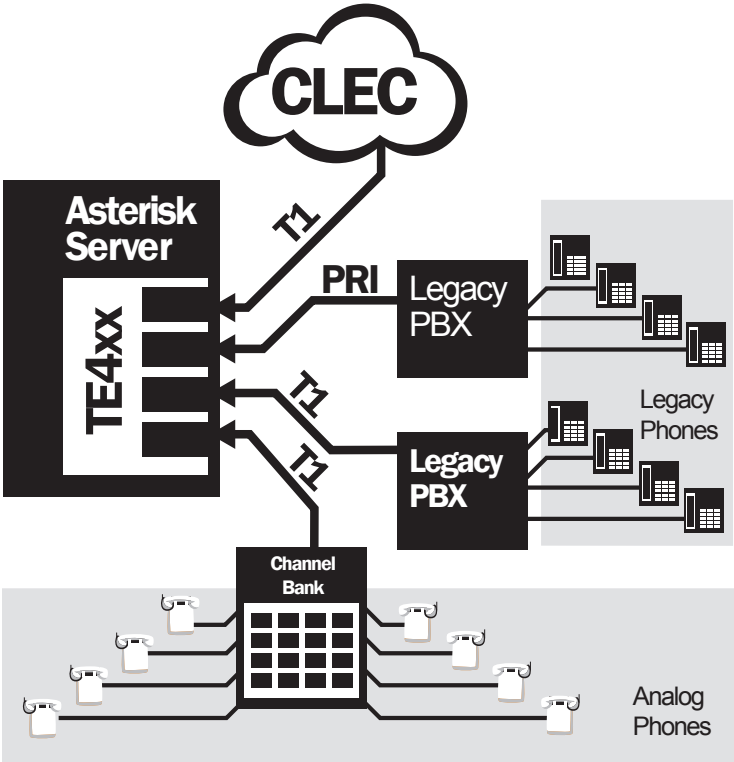

Figure 1: Sample Legacy Phone Application

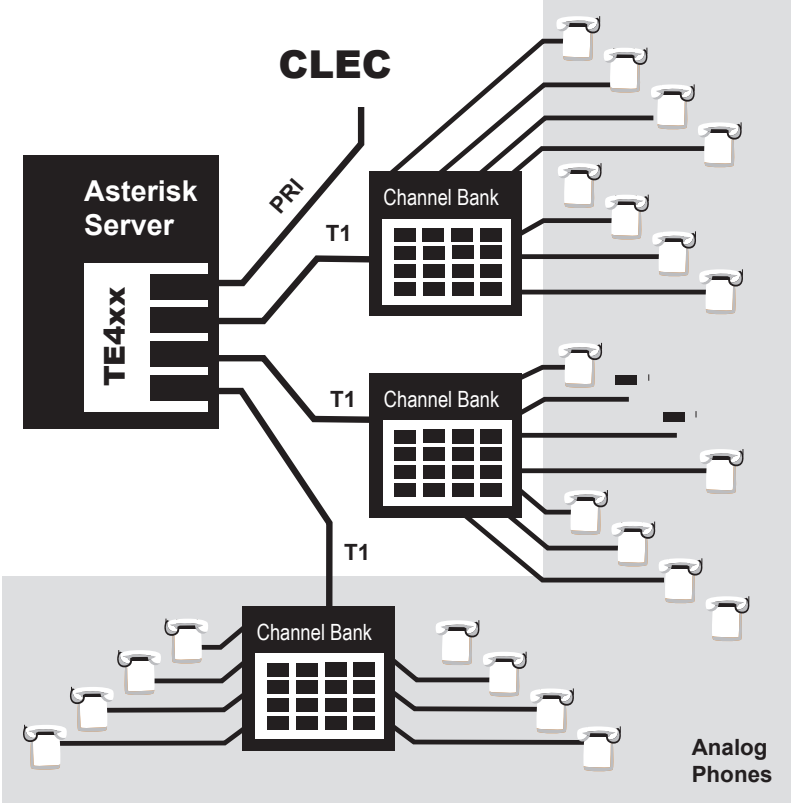

Figure 2: Sample Channel Bank Application

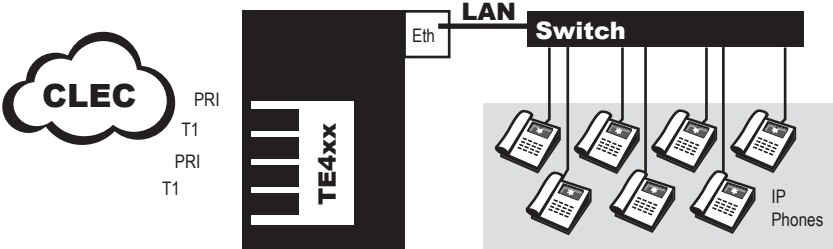

Figure 3: Sample IP Phone Application

Echo-Cancellation

Users connecting their TE400 Series cards to the PSTN or other devices are likely to be placing calls that will result, at some point, in an unbalanced 4-wire/2-wire hybrid. The result of this hybrid is the reflection of a near-end echo to the calling party. Elimination of this echo is the responsibility of echo cancellation.

The TE400 Series cards, unless otherwise equipped, utilize Asterisk to perform software-based echo cancellation. Asterisk maintains a number of open source echo cancelers. These open source echo cancelers provide a moderate level of echo cancellation, but are not capable of dealing with higher levels of, or more advanced, echoes.

Digium recommends that those users concerned about echo cancellation purchase the VPMOCT128 hardware echo cancellation module. The VPMOCT128 may be combined with either the TE405P (as TE407P), TE410P (as TE412P), or TE420 (as TE420B) cards.

The VPMOCT128 is designed to handle up to 128ms of echo cancellation across all channels and provides a G.168 compliant echo cancellation solution.

If equipped and not explicitly disabled in `chan_dahdi.conf`, the VPMOCT128 will automatically operate and cancel all network echo within its tail range (1024 taps). Users may also purchase Digium's commercial HPEC software:

<http://www.digium.com/en/products/software/hpec.php>

What is Asterisk®?

Asterisk is the world's leading open source telephony engine and tool kit. Offering flexibility unheard of in the world of proprietary communications, Asterisk empowers developers and integrators to create advanced communication solutions...for free. Asterisk is released as open source under the GNU General Public License (GPL), and it is available for download free of charge. Asterisk is the most popular open source telephony software available, with the Asterisk Community being the top influencer in VoIP.

Asterisk as a Phone Switch (PBX)

Asterisk can be configured as the core of an IP or hybrid PBX, switching calls, managing routes, enabling features, and connecting callers with the outside world over IP, analog (POTS), and digital (T1/E1/J1/BRI) connections.

Asterisk runs on a wide variety of operating systems including Linux, Mac OS X, OpenBSD, FreeBSD, and Sun Solaris. It provides all of the features you would expect from a PBX including many advanced features that are often associated with high end (and high cost) proprietary PBXs. Asterisk's architecture is designed for maximum flexibility and supports Voice over IP in many protocols, and can interoperate with almost all standards-based telephony equipment using relatively inexpensive hardware.

Asterisk as a Gateway

It can also be built out as the heart of a media gateway, bridging the legacy PSTN to the expanding world of IP telephony. Asterisk's modular

architecture allows it to convert between a wide range of communications protocols and media codecs.

Asterisk as a Feature/Media Server

Need an IVR? Asterisk's got you covered. How about a conference bridge? Yep. It's in there. What about an automated attendant? Asterisk does that too. How about a replacement for your aging legacy voicemail system? Can do. Unified messaging? No problem. Need a telephony interface for your web site? Okay.

Asterisk in the Call Center

Asterisk has been adopted by call centers around the world based on its flexibility. Call center and contact center developers have built complete ACD systems based on Asterisk. Asterisk has also added new life to existing call center solutions by adding remote IP agent capabilities, advanced skills-based routing, predictive and bulk dialing, and more.

Asterisk in the Network

Internet Telephony Service Providers (ITSPs), Competitive Local Exchange Carriers (CLECs) and even first-tier incumbents have discovered the power of open source communications with Asterisk. Feature servers, hosted services clusters, voicemail systems, and pre-paid calling solutions, all based on Asterisk have helped reduce costs and enabled flexibility.

Asterisk Everywhere

Asterisk has become the basis for thousands of communications solutions. If you need to communicate, Asterisk is your answer. For more information on Asterisk, visit <http://www.asterisk.org> or <http://www.digium.com>.

Chapter 2

Card Installation

This chapter provides the following information:

- **Unpacking the Card** on page 22
- **Shipment Inspection** on page 22
- **Identifying Communication Ports** on page 23
- **T1/E1 Selection** on page 25
- **Identifying Multiple Cards** on page 25
- **Connecting Timing Cables** on page 26
- **Slot Compatibility** on page 28
- **Hardware Installation** on page 30
- **Software Installation** on page 31

Note: The TE400 Series card installation instructions are written so that they will apply to any card in the series. Examples and card specific information are included as needed.

Unpacking the Card

When you unpack your card, carefully inspect it for any damage that may have occurred in shipment. If damage is suspected, file a claim with the carrier and contact your reseller from which the card was purchased, or contact Digium Technical Support (+1.256.428.6161). Keep the original shipping container to use for future shipment or proof of damage during shipment.

Note: Only qualified service personnel should install the card. Users should not attempt to perform this function themselves. The installer must ensure that the equipment is permanently connected equipment, pluggable type B or connected to a socket-outlet that has been checked to ensure that it is reliably earthed in accordance with the National Electrical Code.

Shipment Inspection

The following items are included in shipment of the TE400 Series:

- TE400 Series card (TE405P / 407P / 410P / 412P / 420 / 420B)

Identifying Communication Ports

The TE400 Series cards consists of four RJ45 ports and four status LEDs. The ports are used for connecting T1, E1, or J1 cables. Refer to Figure 4 on page 23 or Figure 5 on page 24 to locate the ports and LEDs.

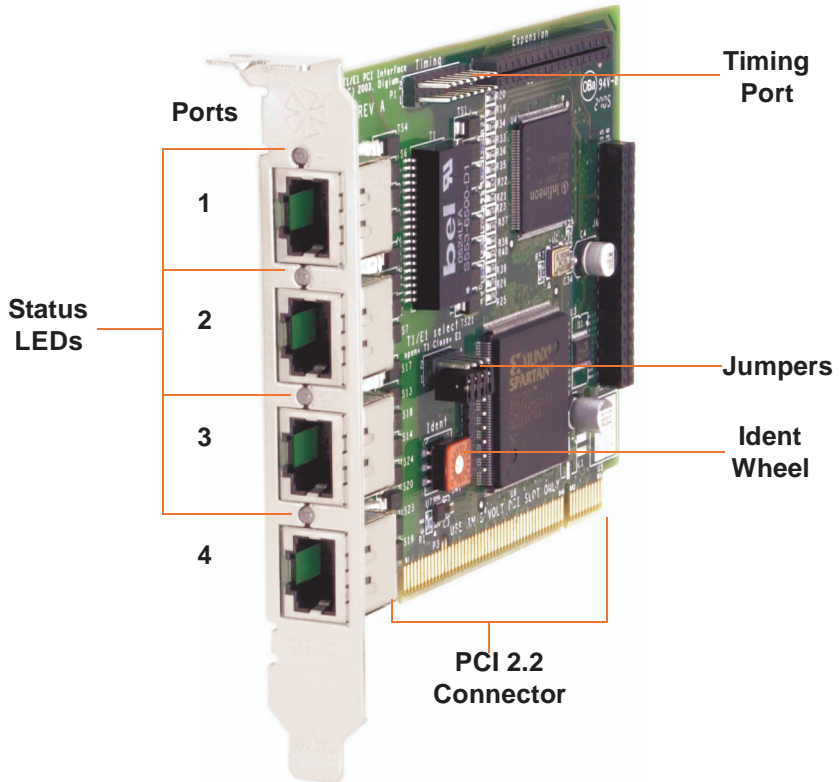

Figure 4: TE405P Card

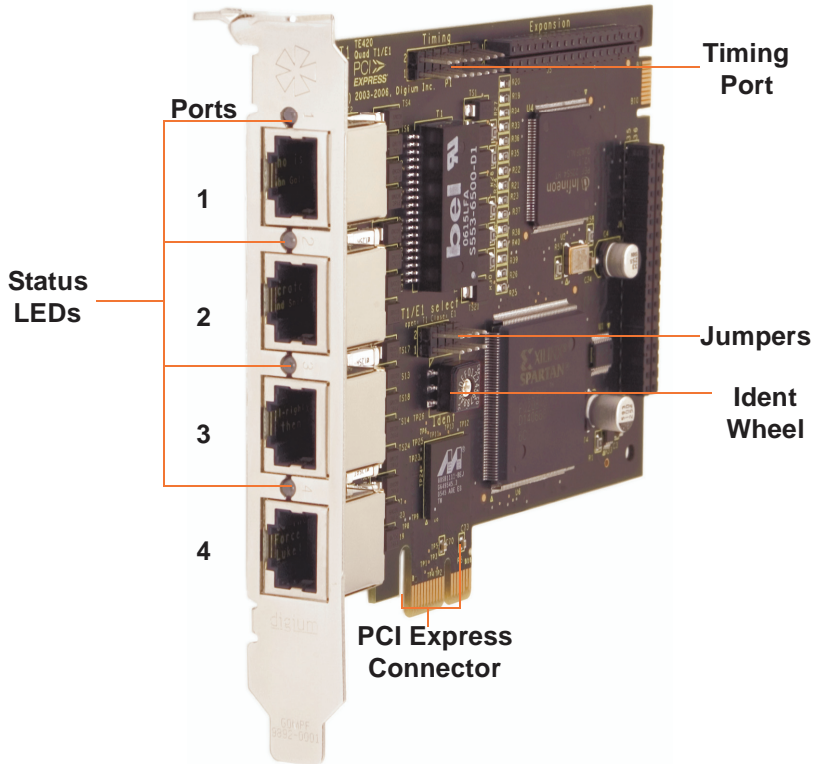

Figure 5: TE420 Card

T1/E1 Selection

The card includes a row of jumpers to select either T1 or E1 mode for the spans. An example of the jumpers from the TE405 card is shown in Figure 6. The T1/E1 mode, in most cases, is set at the distributor before shipment. You may want to check the setting to be certain they are set for your specific use. With the jumper **off**, the span is ready for T1 mode, and with the jumper **on**, the span is ready for E1 mode.

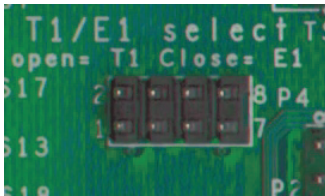

Figure 6: T1/E1 Jumpers

Identifying Multiple Cards

If multiple TE400 Series cards are installed in the same machine, then the **Ident** wheel can be used to control the order the cards are recognized. The click wheel switch with the word **Ident** printed above it can be set to a different number for each installed card. This number adjusts the order in which the driver recognizes the card. For example: set the first card **Ident** wheel to 0, set the second card **Ident** wheel to 1, and so on. The **Ident** wheel is shown in Figure 7.



Figure 7: Ident Wheel

Connecting Timing Cables

The timing port allows up to four TE400 Series cards to share the same sync (timing) source from the T1 line provider, or provide a consistent sync source across multiple cards. This is a useful feature for fax modes and some voice applications to prevent corruption due to timing slips on the second, third or fourth TE400 Series cards.

To utilize this feature, daisy-chain the P1 connector between each TE400 Series card using the Digium 4-position timing cable. See Figure 8 on page 27 for an example. Enable this feature in the drivers using the **timingcable=1** switch when the drivers are loaded:

```
# modprobe wct4xxp timingcable=1
```

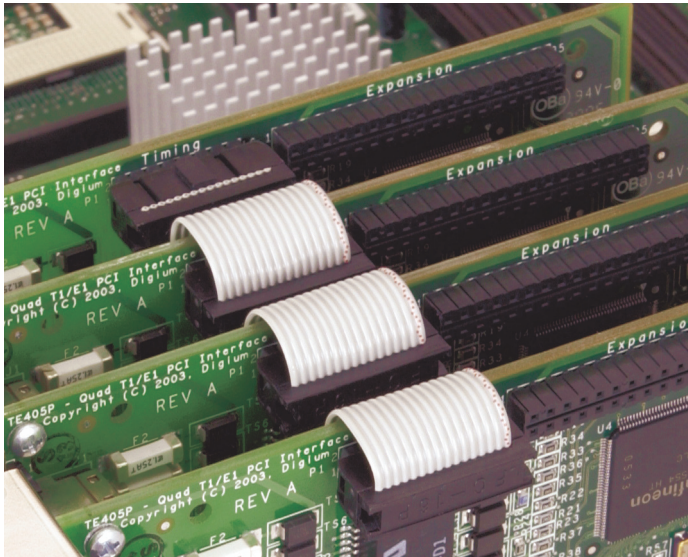

Figure 8: Timing Ports Example



Caution.

Only qualified service personnel should continue with hardware installation and configuration of the TE400 Series card. Non-qualified personnel should not attempt to perform these functions themselves.

Slot Compatibility

Check the type of card you received to be sure it is compatible with your PCI slot. To determine which slot you have, identify it by comparing it to those shown in Figure 9 on page 28.

Slot Number:

- 0: AGP Pro Slot
- 1: 64-bit 5.0 volt PCI Slot
- 2: 64-bit 3.3 volt PCI Slot
- 3: 32-bit 5.0 volt PCI Slot
- 4: PCI Express X1 Slot

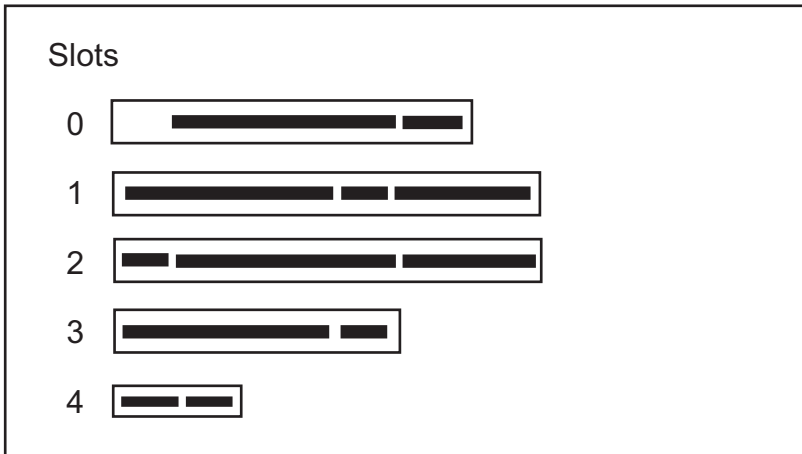

Figure 9: Motherboard Slots

The TE405P/407P card is a 32-bit 33MHz card keyed for 5.0 volt operation and works in any PCI 2.2 (or higher) compliant slot which supports 5.0 volts. This means that in the motherboard shown in Figure 9, the TE405P/407P card will fit into Slots 1 and 3. The TE405P/407P **will not** fit into Slot 0 (AGP slot) or Slot 2.

The TE410P/412P card is a 32-bit 33MHz card keyed for 3.3 volt operation and works in any PCI 2.2 (or higher) compliant slot which supports 3.3 volts. This means that in the motherboard shown in Figure 9, the TE410P/412P card will only fit into Slot 2. The TE410P/412P **will not** fit into Slots 1 or 3.

The TE420/TE420B card is a PCI Express card. Slot 4, illustrated above, is a 1 lane (X1) PCI Express compliant slot. The TE420/TE420B will work in any PCI Express compliant slot, including lane lengths X4, X8, and X16. This means that in the motherboard shown in Figure 9, the TE420/TE420B will only fit into Slot 4. The TE420/TE420B **can not** be used in Slots 1 through 3.

Hardware Installation

1. Now that you are acquainted with the cards, power down your computer and unplug it from its power source.
2. Attach a static strap to your wrist and open the case.
3. Check the jumper setting to ensure it matches your equipment configuration. Setting the jumper with the jumper strap **on** enables the ports for E1. Setting the jumper with the jumper strap **off** enables the ports for T1.
4. Remove the bracket place holder and insert the card into a PCI or PCI Express slot. See Figure 10 for an example of card installation.

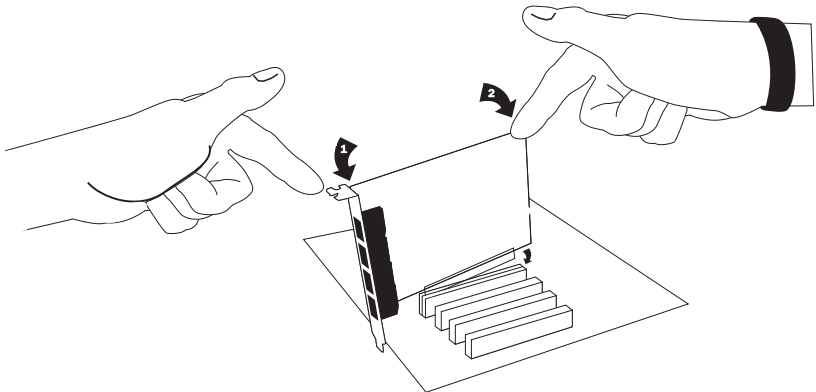

Figure 10: Insert the Card

5. Replace the cover to your computer.
6. Plug all T1 or E1 equipment cables into the RJ45 ports as needed.

Note: Use only shielded cables to ensure compliance with the international EMC standards.

**Caution.**

This unit must be connected to the Telecommunications Network in your country using an approved line cord (e.g. for Australia use only line cords complying with AS/CA S008:2010).

**Caution.**

This unit must be connected only to the appropriate Telecommunications Network port (as approved for use in your specific country).

Software Installation

Digium hardware requires drivers and libraries that are not integrated with the Linux kernel. Digium hardware is only supported under Linux. Digium recommends CentOS, Debian, Red Hat, and Ubuntu distributions of Linux. However, many other distributions are supported by Digium Technical Support.

Digium's software, including drivers and application software, may be obtained from Digium's download server at:

<http://downloads.digium.com>

For an introduction to Asterisk, Digium's telephony software, including additional information on its configuration, setup, and features, please refer to:

<http://www.asterisk.org>

For the latest information on setting up and configuring DAHDI drivers for your Digium hardware product, please refer to the latest release of this manual which is available from the product-specific documentation section at:

<http://www.digium.com>

To install your TE400 Series card, you will need:

- Linux 2.6 kernel headers
- Development libraries and headers for ncurses
- Development libraries and headers for zlib and openssl
- Development libraries and headers for newt
- GCC and standard software build tools

It is recommended that you use the most recent version of the Asterisk, DAHDI, and libpri software for the best results. If you have previously installed any of these, Digium recommends that you upgrade to the latest “-current” version of each.

Note: If you are using the 1.4.x series of Asterisk, you will need Asterisk 1.4.22 or newer.

1. After the machine has booted to Linux, log in and execute the following command to list the devices detected by the PCI bus:

```
# lspci -n
```

Confirm that the output from **lspci** lists a device with Digium's PCI vendor ID which is "d161". The screen output should be similar to the following:

```
0000:01:0e.0 ISDN controller: Unknown device
d161:<card identifier>
```

Note: The output from **lspci** may or may not state "Unknown device". If it does, this does not indicate a problem.

In the PCI device listing shown above, <card identifier> will be populated with one of the identifiers listed in the table below.

Table 1: Card Identifiers

Model	Identifier
TE420B	0420
TE420	0420
TE420	1420
TE412P	0410
TE410P	0410
TE407P	0405
TE405P	0405

A Digium TE400 Series (TE420B / TE420 / 412P / 410P / 407P / 405P) card identifier should be listed. If a matching card identifier is not listed, then your machine is not PCI 2.2 (or higher) or PCI Express compatible, and the card will not work with your motherboard.

2. Download the latest version of libpri. Substitute the version of libpri for the X.X in the command line below. libpri is available for download from:

<http://downloads.digium.com/pub/telephony/libpri>

```
# wget http://downloads.digium.com/pub/telephony/  
libpri/libpri-X.X.current.tar.gz
```

Note: There is no correlation between the versioning of libpri and Asterisk. The libpri 1.4 branch will function with the Asterisk 1.6

branch.

3. Expand the downloaded file, compile its contents, and install the libraries. Substitute the version of libpri for the X.X and X.X.X in the command lines below.

```
# tar -zxvf libpri-X.X-current.tar.gz
# cd libpri-X.X.X/
# make
# make install
```

4. Download the latest DAHDI drivers with tools. DAHDI is available for download from:

<http://downloads.digium.com/pub/telephony/dahdi-linux-complete>

```
# wget http://downloads.digium.com/pub/telephony/
dahdi-linux-complete/dahdi-linux-complete-
current.tar.gz
```

5. Expand the downloaded file, compile its contents, and install the drivers and tools. Substitute the version of DAHDI for the X.X.X in the command lines below.

```
# tar -zxvf dahdi-linux-complete-current.tar.gz
# cd dahdi-linux-complete-X.X.X+X.X.X
# make
# make install
# make config
```

Note: Executing ‘make config’ will install an init script and symlinks which will allow you to start and stop DAHDI as a service.

Installing Asterisk

If you wish to use Asterisk with your new hardware, you can follow the instructions below.

1. Download the latest release version of Asterisk, either 1.4.22 (or later), 1.6.0.1 (or later), or 1.8.0 (or later). Substitute the version of Asterisk for the X.X in the command below. Asterisk is available for download from:

<http://downloads.digium.com/pub/telephony/asterisk>

```
# wget http://downloads.digium.com/pub/telephony/  
asterisk/asterisk-X.X-current.tar.gz
```

2. Expand the downloaded file, compile its contents, and install the application. Substitute the version of Asterisk for the the X.X and X.X.X in the command lines below.

```
# tar -zxvf asterisk-X.X-current.tar.gz  
# cd asterisk-X.X.X/  
# ./configure  
# make menuselect  
# make  
# make install
```

3. If this is the first Asterisk installation on this system, you should install the sample configuration files. To do this, run:

```
# make samples
```

Note: Running this command will overwrite, after making a backup copy, any older Asterisk configuration files that you have in the `/etc/asterisk` directory.

If your installation has failed, it may be because you are missing one or more of the build dependencies, the kernel headers, or the development tools. Please contact your reseller where the card was purchased, or call Digium Technical Support (+1.256.428.6161) for assistance.

Complete instructions for installing Asterisk are available at www.asterisk.org.

Chapter 3

Configuration

The TE400 Series cards have a variety of configuration options. This chapter provides configurations for PRI, channel bank, and E&M wink. These sample configurations are provided to assist you in familiarizing yourself with the flexibility of editing the configuration files to meet your specific needs. The list of possible configurations is too expansive to cover in this user manual.

Configuring Card Features

You will need to modify the **chan_dahdi.conf** file which is located in the `/etc/asterisk` directory in order to configure the essential features of your card. This file is the configuration layer between DAHDI and Asterisk.

Switchtype:

```
national:    National ISDN 2 (default)
dms100:     Nortel DMS100
4ess:      AT&T 4ESS
5ess:      Lucent 5ESS
euroisdn:  EuroISDN
nil:       Old National ISDN 1
qsig:      Q.SIG
```

Echocancel:

Echo Cancellation is enabled in `chan_dahdi.conf` by preceding the channel variable with a variable called `echocancel` and its length in taps (# of milliseconds multiplied by 8); for example:

```
echocancel = yes

channel => 1-23
```

By default, and when setting to "yes," echo cancellation is enabled and set to 16 ms (128 taps). Echo cancellation is explicitly disabled by setting:

```
echocancel = no
```

Digium does not recommend that users set echo cancellation to "no."

Users of open source Asterisk-based echo cancelers also have the following options:

```
echocancel = 128 (this sets 128 taps or 16ms)
```

or

```
echocancel = 256 (this sets 256 taps or 32ms)
```

Users of Digium's HPEC software have the following additional options:

```
echocancel = 512 (this sets 512 taps or 64ms)
```

or

```
echocancel = 1024 (this sets 1024 taps or 128ms)
```

Please note that HPEC consumes extremely high amounts of CPU MIPS that increase as the number of taps are increased. Audio quality issues may result from choosing a taps length greater than the server's ability to process the echo in real-time. If audio quality is affected, reduce the taps length or combine your TE400 Series card with Digium's VPMOCT128.

Users of Digium's VPMOCT128 hardware echo cancellation module will have 128ms of echo cancellation performed at all times unless explicitly disabled by setting the echocancel variable equal to "no."

Signalling:

```
    pri_cpe for CPE side
    pri_net for NET side
```

If you have a T1 PRI, add these lines to the following lines of the sample file.

```
signalling = pri_cpe
switchtype = national
group = 1
context = incoming
channel => 1-23
```

E1 PRI

```
signalling = pri_cpe
switchtype = euroisdn
context = incoming
channel => 1-15,17-31
```

You can also configure a T1 channel bank of phones

```
signalling = fxo_ks
group = 1
context = phones
channel => 1-24
```

E1 channel bank

```
signalling = fxo_ks
group = 1
context = phones
channel => 1-15,17-31
```

Note: More detailed troubleshooting information is provided on <http://www.asterisk.org>.

Configuring T1/E1 Lines

1. Begin by opening the **system.conf** file from the **/etc/dahdi** directory.
2. Specify the two letter country code for your loadzone and defaultzone. This will preload tone zone data and specify a default tone zone for your interfaces.

The following is a typical setup for a telco in the US:

```
loadzone = us
defaultzone = us
```

3. Configure the SPAN Map.

For each T1/E1 you are using, you will need to define a span. The SPAN map includes defining the SPAN number, timing, line build out, framing, and coding. Configuration details for each of these items is explained in this section.

```
span => <Number>,<Timing>,<Line Build
Out>,<Framing>,<Coding>[,Yellow]
```

Number:

This is the port the T1/E1 line is plugged into. Port 1 being the furthest span from the PCI bus. The port numbers are noted on the PCI bracket.

Timing:

This determines how timing is handled by the card.

0 - This span is not used to determine timing. If all spans on the card are set to 0, the card will use its internal clock as the timing source.

1, 2, 3, ... - A value greater than 0 will cause the span to attempt to recover a clock source from the line for the entire card to use as timing. Since only one source of timing is valid per card, this value defines a priority that determines which span recovers a clock in the case that multiple are defined. 1 is the highest priority span, followed by 2, 3, and so on.

Only one span can be defined to take timing, and it defines timing for the rest of the card's spans.

Line Build Out:

For most setups the line build out is 0.

0: 0 db (CSU) / 0-133 feet (DSX-1)

1: 133-266 feet (DSX-1)

2: 266-399 feet (DSX-1)

3: 399-533 feet (DSX-1)

4: 533-655 feet (DSX-1)

5: -7.5db (CSU)

6: -15db (CSU)

7: -22.5db (CSU)

Framing:

T1 utilizes framing set for D4 (SF) or ESF. E1 utilizes CAS or CCS.

Coding:

T1 coding can be AMI or B8ZS. E1 coding can be AMI or HDB3. E1 can also have the extra flag CRC4 at the end for CRC4 checking.

Yellow:

The optional yellow flag can be added at the end for transmitting a yellow alarm when no channels are open.

The following is a typical setup for a telco in the US:

```
span => 1,1,0,esf,b8zs
```

In Europe:

```
span => 1,1,0,ccs,hdb3
```

4. Specify the channel definitions. The format is:

```
<device> = <channel list>
```

A list of valid devices are specified in the sample system.conf file.

The following is a typical setup for a T1 PRI in the US:

```
bchan = 1-23
```

```
dchan = 24
```

5. DAHDI uses modular echo cancellers that are configured per channel. The echo cancellers are compiled and installed as part of the dahdi-

linux package. You can specify the echo canceller to be used for each channel. The default behavior is for there to be no echo canceller on any channel. So, it is very important that you specify one in the system.conf file if you do not have hardware echo cancellers and need echo cancellation. The format is:

```
echocanceller = <echocanceller name>,<channel(s)>
```

A list of valid echo cancellers are specified in the sample system.conf file.

The following is a typical setup for a T1 PRI in the US using software-based echo cancellation:

```
echocanceller = mg2,1-23
```

First Example: Channel Bank

The Channel Bank in this example has 24 FXS ports. In this configuration, the **system.conf** is set for the card to provide timing to the channel bank and **fxoks** is set for 24 stations.

Set **chan_dahdi.conf** to mirror the configuration with **signalling = fxo_ks** and define it for channels 1-24.

```
/etc/dahdi/system.conf:  
loadzone = us  
defaultzone = us  
span = 1,0,0,esf,b8zs  
fxoks = 1-24  
echocanceller = mg2,1-24
```

```
/etc/asterisk/chan_dahdi.conf:  
group = 1  
echocancel = yes  
context = channelbank  
signalling = fxo_ks  
channel = 1-24
```

Second Example: E&M Line

In the E&M Line configuration, the **system.conf** is set for the card to take timing from the telco on E&M with wink while **chan_dahdi.conf** mirrors the configuration. Feat_D is a type of E&M with wink that accepts DID, but there are many other E&M options; E&M_W, E&M, Feat_B, etc.

```
/etc/dahdi/system.conf:  
loadzone = us  
defaultzone = us  
span = 1,1,0,esf,b8zs  
e&m = 1-24  
echocanceller = mg2,1-24
```

```
/etc/asterisk/chan_dahdi.conf:  
group = 1  
echocancel = yes  
context = incoming  
signalling = feat_d  
channel = 1-24
```

Third Example: PRI

By configuring the card for a T1 PRI line in **system.conf**, you acquire 23 bearer (B) channels for voice on the first 23 channels, and 1 delta (D) channel for signalling information on the 24th channel. In the **chan_dahdi.conf** file, define **pri_cpe** as the signalling type to act as the client side. Define the switch type you are connecting to as **national**. You will then have 23 voice channels for Asterisk.

PRI T1:

```
/etc/dahdi/system.conf:
loadzone = us
defaultzone = us
span = 1,1,0,esf,b8zs
bchan = 1-23
dchan = 24
echocanceller = mg2,1-23

/etc/asterisk/chan_dahdi.conf:
group = 1
echocancel = yes
signalling = pri_cpe
switchtype = national
context = incoming
channel = 1-23
```

PRI E1:

```
/etc/dahdi/system.conf:  
loadzone = es  
defaultzone = es  
span = 1,1,0,ccs,hdb  
bchan = 1-15,17-31  
dchan = 16  
echocanceller = mg2,1-15,17-31
```

```
/etc/asterisk/chan_dahdi.conf:  
group = 1  
echocancel = yes  
signalling = pri_cpe  
switchtype = euroisdn  
context = incoming  
channel = 1-15,17-31
```

Testing Your Configuration

1. Load DAHDI drivers into the kernel using the **modprobe** utility. The appropriate driver for the TE400 Series cards is **wct4xxp**. Users in all countries except Australia should use the following modprobe command:

```
# modprobe wct4xxp
# dahdi_cfg -vv
```

2. Run **dahdi_tool** from the command line and see if the span turns green for each span you have connected.

```
# dahdi_tool
```

3. Execute the following Asterisk command to see if the span came up successfully.

```
# asterisk
# asterisk -vvvr
```

Chapter 4

Troubleshooting

This chapter provides frequently asked questions as identified from Digium Technical Support and possible resolutions. Multiple resources are available to obtain more information about Asterisk and Digium products. These resources are listed on page 57.

What do the Status LED colors indicate?

- Green - Card is in-sync with the far end.
- Yellow - Card is synchronizing or is receiving a red alarm from the far end. Use a software tool such as dahdi_tool to get a textual description of the state of the card.
- Red - Card is not seeing far end, circuit is not up, or cable is bad.

I can't receive DID calls even though I have it enabled in extensions.conf.

Your telco might be sending calls with a method you are not expecting.

1. Check the method being used by attempting the following in your line context:

```
_X.,1,NoOp(My DID matches as ${EXTEN})
```

2. Then type `reload` in the Asterisk console and call in. You should see the DID come in on your T1/E1 line.

My D Channel seems to go up and down.

Check to be sure you have set your timing parameters correctly. Also, check the common causes of problems for a T1. See the **Common Fixes for all cards**, page 56.

I have trouble dialing out. It seems that one type of dialing works (local, long distance, international), but another does not.

Check your `pridialplan` variable and verify that you are dialing using the method your telco is expecting.

I am having trouble receiving DID information over E&M.

Try the other types of E&M (featd, featb, etc.) to match the method your telco is using to stream information.

I am having issues with my PRI. How can I see the messages coming across my D channel?

Enter the following command:

```
*CLI> PRI debug span X
```

where `X` is the port from which you are connected. This command will show you the PRI messages coming across your D channel for that span.

I am still having problems and the telco tells me it is my equipment.

The first thing to do in this situation is to test your equipment.

1. Plug in a loopback cable. (A loopback cable is a cable that has pin 1 going to pin 4 and pin 2 going to pin 5.) Plug the cable into the span and wait for its LED to turn green.
2. Stop Asterisk and edit **system.conf** by removing the lines defined for your card and replacing them with the following:

```
span => 1,0,0,esf,b8zs  
clear = 1-24
```

Or if you have an E1 span:

```
span => 1,0,0,ccs,hdb3  
clear = 1-31
```

3. Navigate to the `tools/` directory in your DAHDI complete source directory and type:

```
# make tests
```

Followed by:

```
# ./patlooptest /dev/dahdi/1 60
```

The first argument in the `patlooptest` command is the device for the channel number you want to test. You should always test the first channel of a span. The second argument is the duration in seconds to run the test.

This runs a pattern looptest for 60 seconds. If you receive any failures, it is possible you have a bad card and will need to call Digium Technical Support (+1.256.428.6161)

How can I enable more features?

To view all of the options available to add to your dial plan, type the following commands from within Asterisk:

```
*CLI> core show applications
```

```
*CLI> core show functions
```

Digium also offers services to help configure and add features you might need. Contact Digium Technical Support (+1.256.428.6161) for more information.

Common Fixes for all cards

1. Check to see if the X Window System (e.g. X.Org Server) is running by entering the following:

```
# ps aux | grep X
```

If the X Window System is running, stop the application since it may cause a conflict with Asterisk.

2. Check to see if your PATA IDE hard drives are running with DMA levels set. Advance user can perform an **hdparm** on your hard drive interface.



Use hdparm with caution as the man page states that hard drive corruption can occur when using incorrect settings. Please review the man page for hdparm and make sure you understand the risks before using this tool.

Check the current mode using this command:

```
hdparm -vi /dev/[IDE Device]
```

Use this command to set the drives into UDMA2 mode:

```
hdparm -d 1 -X udma2 -c 3 /dev/[IDE Device]
```

If you are still having problems, contact your reseller from which the card was purchased, or Digium Technical Support (+1.256.428.6161).

Where can I find answers to additional questions?

There are several places to inquire for more information about Asterisk Digium products:

1. Digium Technical Support (+1.256.428.6161), or Toll Free in the U.S. (1.877.344.4861), is available 7am-8pm Central Time (GMT -6), Monday - Friday.
2. Asterisk users mailing list (asterisk.org/lists.digium.com).
3. IRC channel **#asterisk** on (irc.freenode.net).

Subscription Services Program

Digium is dedicated to supporting your Asterisk system by offering full technical support through our Subscription Services Program. Through this program, you can be at ease knowing that your business will always have access to the Asterisk experts. Pricing on Subscription Services may be obtained from your nearest reseller or you may call Digium Sales for referral to your nearest reseller at +1.256.428.6000 or e-mail sales@digium.com.

Appendix A

Pin Assignments

All four ports on the TE400 Series card bracket are 8-pin RJ45 ports. The pin assignments are identified in Table A-1.

Table A-1: RJ45 Telco Port Connector

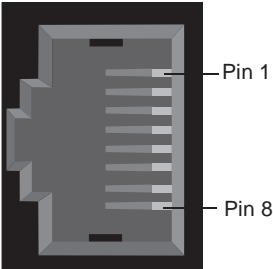
	Pin	Description
	1	Rx
	2	Rx
	3	Not used
	4	Tx
	5	Tx
	6	Not used
	7	Not used
	8	Not used

Appendix B

Specifications

This appendix provides specifications, required environmental conditions, and maximum power consumption for the TE400 Series cards.

Physical (All Cards).

Size: 5" × 3.75" × 0.63" (12.7 x 9.53 x 1.6 cm)
PCB size, does not include the PCI bracket

Weight: 3.5 oz (100gm) - Without Echo Cancellation Module

Interfaces.

Local Loop Access: E1, T1, J1, PRI; RJ45
(TE405P/407P/410P/412P) - PCI Bus: 3.3V or 5V bus slot, half-length slot minimum size, 33MHz minimum bus speed, compliant with PCI 2.2 or greater.
(TE420) - PCI-E X1, compliant with PCI-E X1 1.0 or greater.

Environment.

Temperature: 0 to 50° C (32 to 122° F) operation
-20 to 65° C (4 to 149° F) storage

Humidity: 10 to 90% non-condensing

Hardware and Software Requirements.

800-Mhz Pentium III or better

64MB RAM

Available PCI (TE405P/407P/410P/412P) or PCI-E (TE420) Slot

Table B-2: Maximum Power Consumption

Model	Power
TE420B 3.3V	5 Watts
TE420 3.3V	2.5 Watts
TE412 3.3V 5V	3.0 Watts 0.5 Watts
TE410 3.3V 5V	2.0 Watts 0 Watts
TE407 3.3V 5V	3.0 Watts 0.5 Watts
TE405 3.3V 5V	2.0 Watts 0 Watts

Appendix C

Glossary and Acronyms

ACD *Automatic Call Distribution*

A technology that distributes incoming calls to a specific group of devices that are associated to agents. Asterisk's Queue application performs automatic call distribution.

ANSI *American National Standards Institute*

An organization which proposes and establishes standards for international communications.

asynchronous

Not synchronized; not timed to an outside clock source. Transmission is controlled by start bits at the beginning and stop bits at the end of each character. Asynchronous communications are often found in internet access and remote office applications.

attenuation

The dissipation of a transmitted signal's power as it travels over a wire.

bandwidth

The capacity to carry traffic. Higher bandwidth indicates the ability to transfer more data in a given time period.

bit

The smallest element of information in a digital system. A bit can be either a zero or a one.

bps *bits per second*

A measurement of transmission speed across a data connection.

BRI

Basic Rate ISDN

broadband

Broadband transmission shares the bandwidth of a particular medium (copper or fiber optic) to integrate multiple signals. The channels take up different frequencies on the cable, integrating voice, data, and video over one line.

channel

A generic term for an individual data stream. Service providers can use multiplexing techniques to transmit multiple channels over a common medium.

Cat5

Category of Performance for wiring and cabling. Cat 5 cabling support applications up to 100 MHz.

Cat5E

Category of Performance for wiring and cabling. Category 5 Enhanced wiring supports signal rates up to 100 MHz but adheres to stricter quality specifications.

CLEC *Competitive Local Exchange Carrier*

A term for telephone companies established after the Telecommunications Act of 1996 deregulated the LECs. CLECs compete with ILECs to offer local service. See also *LEC* and *ILEC*.

CO *Central Office*

The CO houses local switching equipment. All local access lines in a particular geographic area terminate at this facility (which is usually owned and operated by an ILEC).

CPE *Customer Premises Equipment*

Terminal equipment which is connected to the telecommunications network and which resides within the home or office of the customer. This includes telephones, modems, terminals, routers, and television set-top boxes.

DAHDI *Digium Asterisk Hardware Device Interface*

A telephony project dedicated to implementing a reasonable and affordable computer telephony platform into the world marketplace. In addition, the collective name for the Digium-provided drivers for Digium telephony interface products.

DS0 *Digital Signal, Level 0*

A voice grade channel of 64 kbps. The worldwide standard speed for digitizing voice conversation using PCM (Pulse Code Modulation).

DS1 *Digital Signal, Level 1*

1.544 Mbps in North America (T1) and Japan (J1) -up to 24 voice channels (DS0s), 2.048 Mbps in Europe (E1) - up to 32 voice channels (DS0s). DS1/T1/E1 lines are part of the PSTN.

DS3 *Digital Signal, Level 3*

T3 in North America and Japan, E3 in Europe. Up to 672 voice channels (DS0s). DS3/T3/E3 lines are not part of the PSTN.

DTMF *Dual Tone Multi-Frequency*

Push-button or touch tone dialing.

E1

The European equivalent of North American T1, transmits data at 2.048 Mbps, up to 32 channels (DS0s).

E3

The European equivalent of North American T3, transmits data at 34.368 Mbps, up to 512 channels (DS0s). Equivalent to 16 E1 lines.

EMI *Electromagnetic Interference*

Unwanted electrical noise.

full duplex

Data transmission in two directions simultaneously.

FXO *Foreign Exchange Office*

Receives the ringing voltage from an FXS device. Outside lines are connected to FXO ports.

FXS *Foreign Exchange Station*

Initiates and sends ringing voltage. Phones are connected to FXS ports.

G.711

A recommendation by the Telecommunication Standardization Sector (ITU-T) for an algorithm designed to transmit and receive mulaw PCM voice and A-law at a digital bit rate of 64 kbps.

G.723.1

A recommendation by the Telecommunication Standardization Sector (ITU-T) for an algorithm designed to transmit and receive audio at 6.3 kbps or 5.3 kbps.

G.729a

A recommendation by the Telecommunication Standardization Sector (ITU-T) for an algorithm designed to transmit and receive audio at 8 kbps.

H.323

A recommendation by the Telecommunication Standardization Sector (ITU-T) for multimedia communications over packet-based networks.

HDLC *High-Level Data Link Control*

A bit-oriented synchronous data link layer protocol developed by the International Organization for Standardization (ISO).

IAX *Inter-Asterisk eXchange*

The native VoIP protocol used by Asterisk. It is an IETF standard used to enable VoIP connections between Asterisk servers, and between servers and clients that also use the IAX protocol.

iLBC *internet Low Bitrate Codec*

A free speech codec used for voice over IP. It is designed for narrow band speech with a payload bitrate of 13.33 kbps (frame length = 30ms) and 15.2 kbps (frame length = 20ms).

ILEC *Incumbent Local Exchange Carrier*

The LECs that were the original carriers in the market prior to the entry of competition and therefore have the dominant position in the market.

interface

A point of contact between two systems, networks, or devices.

ISO *International Standards Organization*

IVR *Interactive Voice Menu*

An interactive technology that allows a telephone system to detect voice and keypad input.

LED *Light-emitting Diode*

Linux

A robust, feature-packed open source operating system based on Unix that remains freely available on the internet. It boasts dependability and offers a wide range of compatibility with hardware and software. Asterisk is supported exclusively on Linux.

loopback

A state in which the transmit signal is reversed back as the receive signal, typically by a far end network element.

MGCP *Media Gateway Control Protocol*

multiplexing

Transmitting multiple signals over a single line or channel. FDM (frequency division multiplexing) and TDM (time division multiplexing) are the two most common methods. FDM separates signals by dividing the data onto different carrier frequencies, and TDM separates signals by interleaving bits one after the other.

mux *multiplexer*

A device which transmits multiple signals over a single communications line or channel. See multiplexing.

node

A terminal in a computer network.

NT *Network Termination*

A device connecting the customer's telephone or data equipment to the local ISDN exchange carrier's line. NT devices are connected to TE devices.

PBX *Private Branch Exchange*

A smaller version of a phone company's large central switching office. Example: Asterisk.

PCI *peripheral component interconnect*

A standard bus used in most computers to connect peripheral devices.

POP *Point of Presence*

The physical connection point between a network and a telephone network. A POP is usually a network node serving as the equivalent of a CO to a network service provider or an interexchange carrier.

POTS *Plain Old Telephone Service*

The public switched telephone network (PSTN) is the network of the world's public circuit-switched telephone networks. Originally a network of fixed-line analog telephone systems, the PSTN is now almost entirely digital, and now includes mobile as well as fixed telephones.

PPP *Point-to-Point Protocol*

Type of communications link that connects a single device to another single device, such as a remote terminal to a host computer.

PRI

Primary Rate ISDN

PSTN *Public Switched Telephone Network*

A communications network which uses telephones to establish connections between two points. Also referred to as the dial network.

PTMP *Point-to-Multipoint*

A connection where data is broadcast between more than two endpoints.

PTP *Point-to-Point*

A connection restricted to two endpoints.

PTT *Post, Telegraph, and Telephone*

The government agencies in many countries that traditionally operated and monopolized the public postal, telegraph, and telephone services.

QoS *Quality of Service*

A set of quality requirements for telephone service.

RBOC *Regional Bell Operating Companies*

The creation of Regional Bell Operating Companies were a result of AT&T's telephone monopoly being broken up in 1983.

REN *Ringer Equivalence Number*

An arbitrary value which denotes the electrical load a telephone ringer has on a line.

RJ11

A six-pin jack typically used for connecting telephones, modems, and fax machines in residential and business settings to PBX or the local telephone CO.

SIP *Session Initiation Protocol*

An IETF standard for setting up sessions between one or more clients. It is currently the leading signaling protocol for Voice over IP, gradually replacing H.323.

T1

A dedicated digital carrier facility which transmits up to 24 voice channels (DS0s) and transmits data at 1.544 Mbps. Commonly used to carry traffic to and from private business networks and ISPs.

T3

A dedicated digital carrier facility which consists of 28 T1 lines and transmits data at 44.736 Mbps. Equivalent to 672 voice channels (DS0s).

TDM *Time Division Multiplexer*

A device that supports simultaneous transmission of multiple data streams into a single high-speed data stream. TDM combines signals by interleaving bits one after the other.

TE *Terminal Equipment*

A device that is established as a point of termination of a communications circuit or channel. Terminal equipment comprises all customer premises equipment (CPE). TE devices are connected to NT devices.

telco

A generic name which refers to the telephone companies throughout the world, including RBOCs, LECs, and PTTs.

tip and ring

The standard termination on the two conductors of a telephone circuit; named after the physical appearance of the contact areas on the jack plug.

twisted pair

Two copper wires commonly used for telephony and data communications. The wires are wrapped loosely around each other to minimize radio frequency interference or interference from other pairs in the same bundle.

V *Volts*

VoIP *Voice over Internet Protocol*

Technology used for transmitting voice traffic over a data network using the Internet Protocol.