

Item
Model
ProjectName



## MMG

The Dito Electrolux meat mincer/graters are ideal for mincing meat for ragout, hamburgers, meat balls, sausages as well as for grating bread, cheese and nuts. Their versatility makes them an essential appliance for kitchens of any size.

603539

## FEATURES

- Constructed in polished aluminum and steel with AISI 304 stainless steel mincing unit, plate, self sharpening knife, funnel and connection container.
- Micro switch positioned on the handle prevents accidental contact.
- Easy to use control panel.
- Protection grill is positioned beneath the grating cylinder to avoid accidental contact.
- Provided with a helical (ventilated) oil bath gear motor. The motor is protected by a thermal fuse.
- The grinding unit can be easily removed for simple cleaning.

# Meat Mincer/Grater



**DITO****Electrolux**

- Model 603539 has a grater motor that may run at up to 900 rpm and a meat mincer motor may run at up to 140 rpm. Model 603540 has a grater motor that may run at up to 1.400 rpm and a meat mincer motor may run at up to 210 rpm.
- Plate diameters of 70 mm for model 603539 and of 82 mm for model 603540.

- Stainless steel meat mincer loading hopper and stainless steel collecting tray included.
- Stainless steel perforated grating cylinder (75 x 140 mm).

## Specifications

MODEL	MMG12 603539	MMG22 603540
External dimensions - mm		
width	270	280
depth	600	620
height	400	430
Electrical power - kW	0.75	1.1
Net weight - kg.	21	22
Supply voltage	400 V, 3N, 50	400 V, 3N, 50
Meat mincer		
Productivity kg/h	150-200	250-300
Loading hopper dimensions mm	275 x 200 x 50	370 x 245 x 50
Collecting tray dimensions mm	235 x 196 x 50	310 x 235 x 50
Grater		
Productivity kg/h - cheese	50	130
Productivity kg/h - bread	100	150
Collecting tray dimensions mm	Ø 230 x h 100	Ø 230 x h 100
Outlet dimensions mm	95 x 145 x 75	95 x 145 x 75



**DITO**

**Electrolux**

## Installation drawings

**603539**

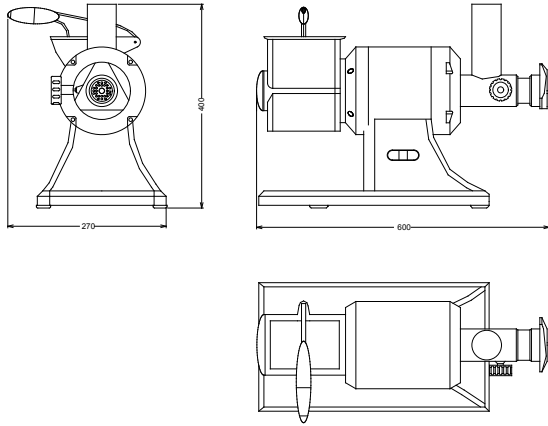

**603540**

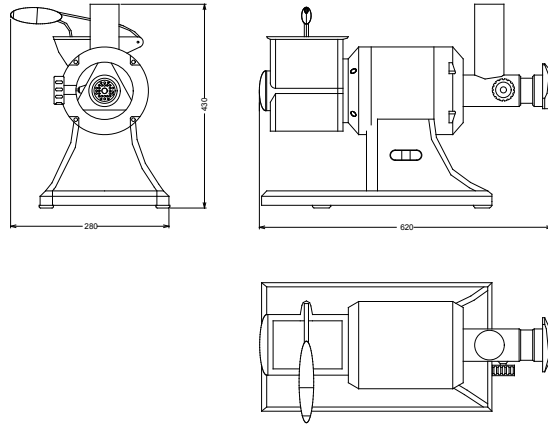

**MODEL**

I - Electrical connection

**MMG12**  
**603539**

400 V, 3N, 50

**MMG22**  
**603540**

400 V, 3N, 50

The manufacturer reserves the right to modify and make improvements to the products without giving prior warning. Dimensions, illustrations, technical data, weights, etc. are given as an indication only.



[www.dito-electrolux.com](http://www.dito-electrolux.com)

# Meat Mincer/Grater

AEBA010

