

*Bridge Navigational Watch Alarm System
acc. MSC .128/75*

*le guardian 2025
user manual*



*operating device
LOD 210.24.0.0
with display, key switch & rotary
encoder w. push button*



*connecting module
LCM 210.24.0.0*

contents

- 1 instruction for use
- 2 installation
- 3 commissioning
- 4 test mode (maintenance & service)
- 5 trouble shooting
- 6 centralized dimmer
- 7 adjust time period of alarm stage 2 (alarm in officer's area)
- 8 adjust buzzer characteristics & volume
- 9 technical data & schematics
- 10 user manual short version (for users only)

1 instruction for use

le guardian 2025 and its extension devices (time period reset units, alarm devices) must only be installed by trained electricians or other persons who are familiar with installation of electric equipment.

Parts of the system can be damaged and persons put at risk if system is connected incorrectly.

Connecting module (LCM 210.24.0.0) is designed to be installed in an enclosure switch cabinet or control console. For service and commissioning work connecting module should be installed in such manner, service personnel is able to see state LEDs on module.

Operating device (LOD 210.24.0.0) is designed to be installed on control console.

Operating device and all time period reset units have to be installed only at locations on bridge or bridge wings where OOW has a proper look out.

Installation must conform to regulations for electromagnetic compatibility (EMC). (see chapter technical data & schematics)

2 installation

Connecting module (LCM 210.24.0.0) and its extension devices (time period reset units, alarm devices) have to be connected according to corresponding wiring diagrams.

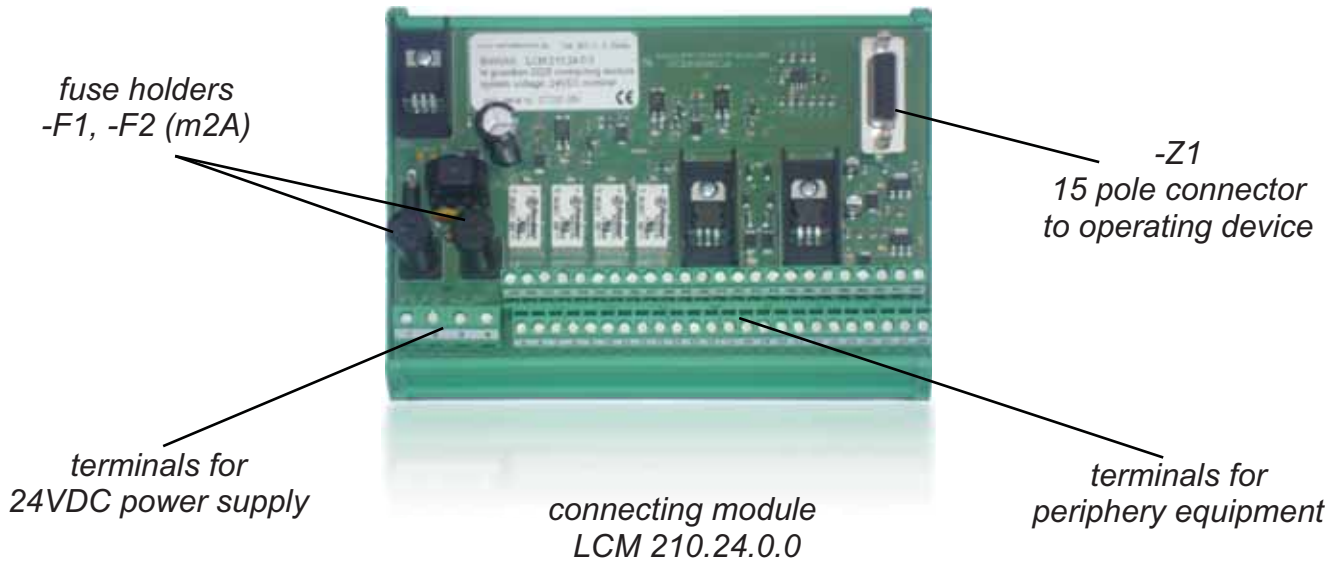

description

connecting module (LCM 210.24.0.0)

Module has been designed to click on terminal rail TS 35 inside electric cabinet or control console. All periphery equipment (time period reset units, alarm panels, power supply) is to be connected directly on connecting module without any additional terminal board or distribution boxes according to wiring diagram which is part of working drawings. Sample system wiring diagram is shown in chapter “technical data & schematics”.

Outputs for “power on” indication and time period reset push button illumination are short-cut protected. Maximum loads of outputs and output contacts see chapter “technical data & schematics”.



operating device (LOD 210.24.0.0)

Before mounting operating device into cut-out, plug on 15-pole system cable on device's rear side and tighten it properly. Use device clamps to fix device in proper manner.

Do not use longer system cable as standard length: l=3m!

Plug on 15-pole system cable on connecting module LCM 210.24.0.0 (-Z1) and tighten it properly.

After connecting all additional equipment (time period reset units, alarm devices) according to corresponding wiring diagram, system is ready for operating.

3 commissioning

Before switching on 24VDC (nominal) power supply to connecting module LCM 210.24.0.0 terminal board –X1: 1,2 (+) & 3,4 (-) make sure power supply, time period reset units and external alarm devices have been connected correctly according to wiring diagram.

Diode on LCM 210.24.0.0 connecting module secures system against wrong power supply polarity.

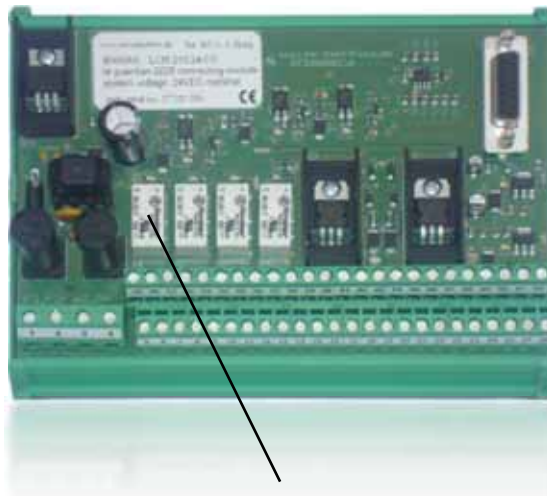

*system fail relay
K1 with control LED 1*

After switching on 24VDC power supply (generally from 24VDC Emergency Distribution Board) system fail relay K1 is activated and display on operating device LOD 210.24.0.0 shows “text 1” after a short intro procedure.

In case of system fail, relay K1 is not activated (control LED 1 is switched off). When system is running properly, relay K1 is triggered and its potential free contact is closed (-X1: 5, 6)

Make sure that up to now no external “power on” contact (steady contact: - X1:29, 30 and pulsed contact: -X1: 26, 27 & 50, 51) is active.

display „text 1“

**READY FOR
POWER ON / AUTO**

System is running now and is waiting for user’s operation on operating device LOD 210.24.0.0 or for an external “power on” command. Display shows “text1”.

Switch on system by turning key switch S1 on operating device LOD 210.24.0.0 one time to position "ON/OFF"

After system is switched on default dormant period (3:00min) is counting down and display shows current state of count-down (display "text 3").



display „text 2“



Test of external illuminated time period reset unit:

In this "count-down mode" all illuminated time period reset units are activated. Illumination of display and of reset units is adjustable by turning rotary encoder. Minimum illumination is fixed.

Now push external reset units (one by one) and check 2nd line of display (current value). Every reset should restart count-down (2:59).

Test of external “power on” devices: (optional)

In case external “power on” devices are involved, activate these devices (one by one). Make sure before, display “text 1” is shown. Only in this “auto mode” an external “power on” is possible.

display „text 1“

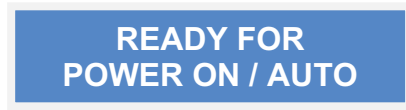

notice:

Every switching on (from operating device LOD 210.24.0.0 or from external devices) restarts count-down!

Test of external alarm devices and links

For checking alarm devices (external buzzers on bridge or bridge wing area, alarm panels in officer’s area, link to general alarm system, link to VDR system and system failure contact see chapter 4 “test mode” (maintenance & service)

For finishing commissioning procedure “switch off” system by turning key switch S1 on operating device LOD 210.24.0.0 to position “ON/OFF” for longer than 2 sec.

Display shuts down and system ignores all external inputs now.

*system is
shut down*



4 test mode (maintenance & service)

The guardian 2025 Bridge Navigational Watch Alarm System owns a test mode procedure to check all output relevant devices (alarm panels, external buzzers, links to alarm devices, links to VDR and system failure contact) in a very comfortable manner.

To reach this “*service mode*” an authorized person has to “switch off” system by turning key switch S1 on operating device LOD 210.24.0.0 to position “ON/OFF” for longer than 2 sec. System shuts down. After that authorized person has to keep pushing rotary encoder push button S2 and after a period between 2 and 3 sec he has to “switch on” system by turning key switch S1 on operating device LOD 210.24.0.0 one time to position “ON/OFF”



System starts in “*service mode*” and display is showing “text 4”

display „text 4“

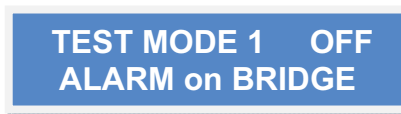

By pushing rotary encoder’s push button S2 for one time, all internal and external bridge area alarm devices (alarm stage 1) are activated as long as push button S2 is pushed again. During this manual alarm activation, display is showing “text 5”.

display „text 5“

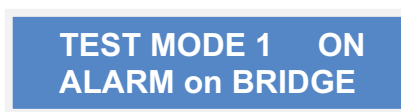

After a.m. test in “test mode 1” is done, user has to turn rotary encoder clockwise to reach “test mode 2”.

display „text 6“

**TEST MODE 2 OFF
OFFICERs ALARM**

Display is showing “text 6” and after pushing rotary encoder’s push button S2 for one time, all alarm devices in officer’s area (alarm stage 2) and link to VDR system (optional) are activated as long as push button is pushed again.

During this manual alarm activation, display is showing “text 7”.

display „text 7“

**TEST MODE 2 ON
OFFICERs ALARM**

After a.m. test in “test mode 2” is done, user has to turn rotary encoder clockwise to reach “test mode 3”.

display „text 8“

**TEST MODE 3 OFF
ALARM STAGE 3**

Display is showing “text 8” and after pushing rotary encoder’s push button S2 for one time, system’s contact is activating very loud alarm devices in officer’s area (alarm stage 3) and link to VDR system (optional) as long as push button is pushed again.

During this manual alarm activation, display is showing “text 9”.

display „text 9“

**TEST MODE 3 ON
ALARM STAGE 3**

After a.m. test in “test mode 3” is done, user has to turn rotary encoder clockwise to reach “test mode 4”.

display „text 10“

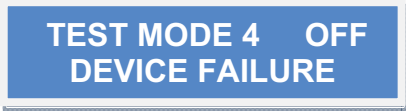

Display is showing “text 10” and after pushing rotary encoder’s push button S2 for one time, device’s failure contact opens and activate linked alarm system as long as push button S2 is pushed again.

Consider possible alarm delay period created by linked alarm system!

During this manual alarm activation, display is showing “text 11”.

display „text 11“



State of all output relays is shown by corresponding control LEDs. Consider reversed relay logic of system failure relay K1!

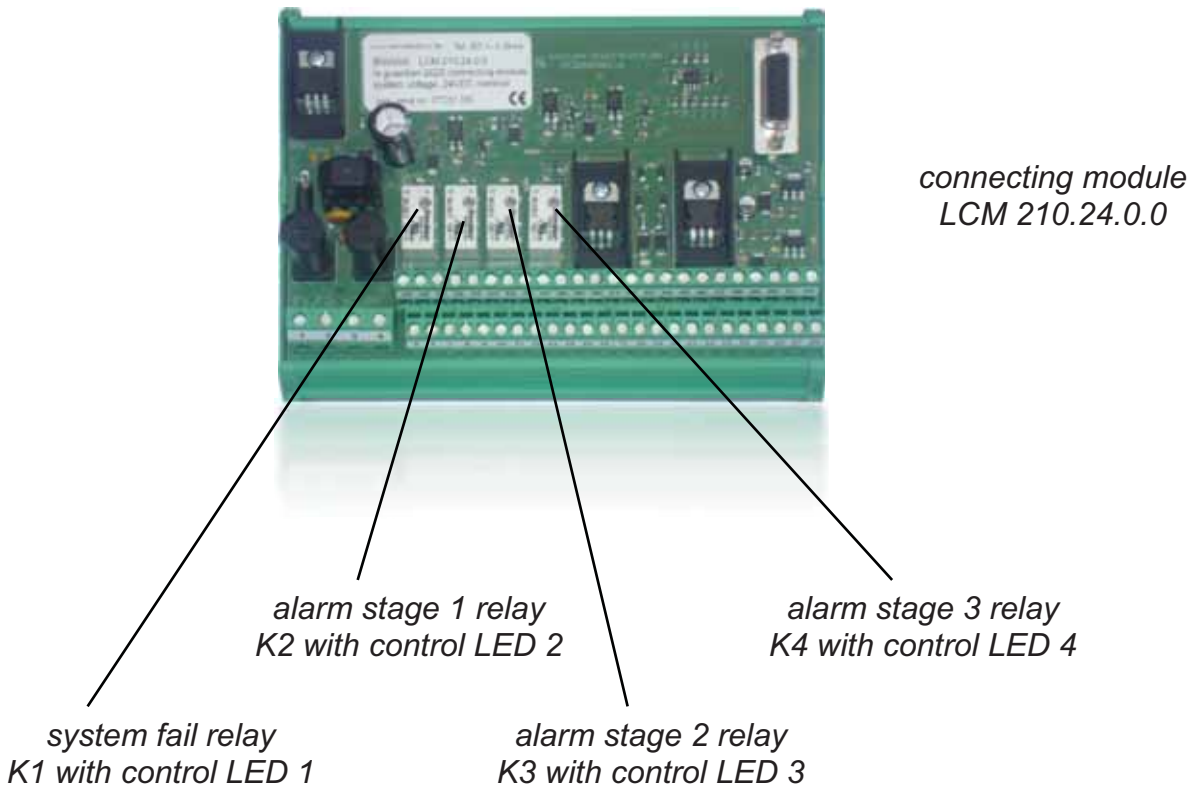

For finishing “test mode” procedure “switch off” system by turning key switch S1 on operating device LOD 210.24.0.0 to position “ON/OFF”.



5 trouble shooting

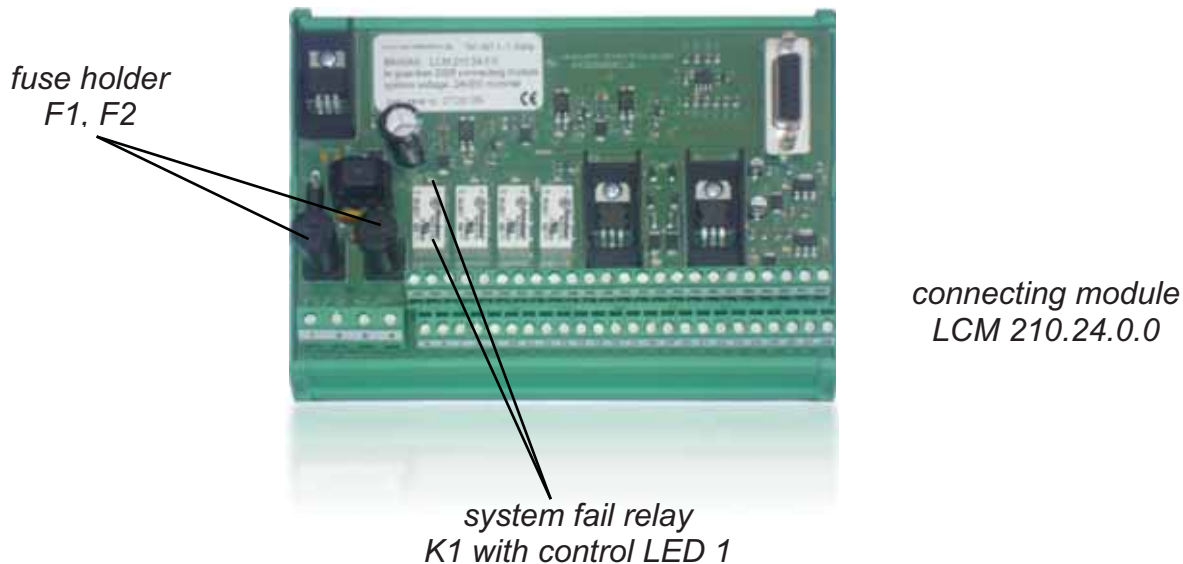

system fail criteria

In following cases potential free (dry) n/o contact on connecting module LCM 210.24.0.0

–X1: 5,6 opens (system fail state):

- a) power supply failed (or main power supply voltage is lower than 13,2V)**
- b) program cycle interrupted (risc controller has been stopped)**
- c) link with 15 pole system cable Z1 between operating device and connecting module is interrupted**

- a) check supply voltage by comparing it with other systems fed from same distribution source.
- b) Switch off system's power supply for minimum 10 sec by opening fuse holder F1 or F2 on connecting module LCM 210.24.0.0. After switching on power supply, program will start automatically after 2 sec. in "normal mode".
- c) check system cable between connecting module LCM 210.24.0.0 and operating device LOD 210.24.0.0, especially system plug on operating device's rear side. Cable might be damaged.

System fail state is indicated when system fail relay K1 is not triggered (control LED D9 is off).

Notice:

In case that during watch operations system's power supply fails temporary (e.g. black-out situation) watch operations restart automatically with old settings (settings before power fail).

time period cannot reset, emergency call cannot reset

check all reset units if reset contact is closed permanently by switch's malfunction or accidental use.

No indication light is active (reset units & external "power on" devices)

Check if system is might be "switched off" by external system. Use key switch S1 on operating device LOD 210.24.0.0.

Notice:

time period reset unit illumination and external "power on" indication are active only, when count-down sequence is started.

If system works properly but without any indication, one bulb or LED in time period reset units or external "power on" devices might be blown in that way, causing a short-circuit. Replace damaged bulb / LED. Short-circuit does not damage system due to short-circuit protected transistor outputs.

6 centralized dimmer

le guardian 2025 BNWAS is designed with a centralized dimmer function. That means all relevant illuminated time period reset units on bridge and bridge wing area as well as blue display on operating device LOD 210.24.0.0 are adjustable by turning rotary encoder S2 on operating device LOD 210.24.0.0. Minimum illumination is limited. Display's illumination and time period reset unit's illumination are synchronized.



By turning rotary encoder S2 on operating device LOD 210.24.0.0 in counter clock wise direction, illumination is decreasing. By turning rotary encoder S2 on operating device LOD 210.24.0.0 in clockwise direction, illumination is increasing.

Notice:

dimmer function is suppressed during any kind of settings changing procedure by using rotary encoder!

7 adjust time period of alarm stage 2 (alarm in officer's area) (for authorized persons only)

IMO regulations allow (MSC 75/24/Add.1 ANNEX 11, 4.1.2.7) to increase standard setting of 90 sec of alarm stage 2 (alarm in officer's area). Compare with chapter 9 technical data and schematics (see watch alarm time table). Adjustment could be necessary due to large vessel. Period can be adjusted to max. 180sec (default value is 90sec), to allow sufficient time for back-up officer and/or Master to reach bridge area before watch alarm system is triggering alarm stage 3.

Write down decided new value here:

new time period of alarm stage 2
[90sec.... 180sec]

date & sign

To adjust a.m. time period turn key switch S1 on operating device LOD 210.24.0.0 to position "SELECT".



After turning key switch S1 to position “SELECT” display is showing “text 3”.

display „text 3“

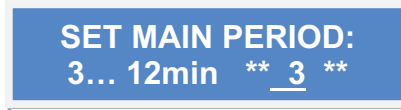

Now push rotary encoder’s push button S2 on operating device LOD 210.24.0.0 so often as display is showing “text 24”.

display „text 24“



Now turn rotary encoder in clockwise direction to increase time period value or in counter-clock wise direction to decrease time period value. System allows only values between 90 and 180sec. By pushing rotary encoder’s push button S2 on operating device LOD 210.24.0.0 display is changing and system accepts adjusted value.

8 adjust buzzer characteristics & volume

le guardian 2025 system is designed with adjust mode to be able to change steady internal and external alert tone into 7 additional individual buzzer characteristics in case other systems on bridge area are generating a similar alert tone.

Adjust buzzer's characteristic

To adjust buzzer's characteristic turn key switch S1 on operating device LOD 210.24.0.0 to position "SELECT".



After turning key switch S1 to position "SELECT" display is showing "text 3".

display „text 3“

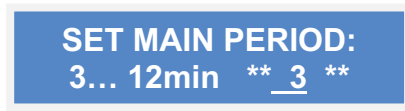

Now push rotary encoder's push button S2 on operating device LOD 210.24.0.0 so often as display is showing "text 22".

display „text 22“

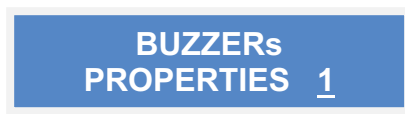

Now turn rotary encoder to choose an adequate buzzer characteristic. By pushing rotary encoder's push button S2 display is changing and system accepts adjusted value.

**Do not accept offered buzzer characteristics during buzzer is activated
(Wait for the brake!)**

Adjust internal buzzer's volume

To adjust internal buzzer's volume turn key switch S1 on operating device LOD 210.24.0.0 to position "SELECT". Minimum sound volume is limited to 65dB(A)



After turning key switch S1 to position "SELECT" display is showing "text 3".

display „text 3“

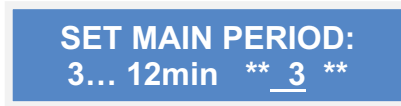

Now push rotary encoder's push button S2 on operating device LOD 210.24.0.0 so often as display is showing "text 23".

display „text 23“



Now turn rotary encoder in counter clock wise direction to decrease buzzer's sound volume or in clock wise direction to increase sound volume. By pushing rotary encoder's push button S2 display is changing and system accepts adjusted value.

Notice:

During alarm stage 1 (alarm on bridge & bridge wing area) internal buzzer's sound volume can be adjusted by turning rotary encoder on operating device!

9 technical data and schematics

generals

description: le guardian 2025 BNOWS
 power supply: 24VDC (nominal), 18,0... 31,2VDC, nominal feeding value: B4A
 power consumption: min. 60mA, max. 400mA, nominal value: 120mA
 internal fuses: 2x m2,0A, 5x20mm
 degree of enclosure: acc. EN 60529 see table
 weight: connecting module: 330g, operating device: 200g
 approbation: design & manufacturing acc. IEC 60945, type approvals: GL,
 transistor outputs: "power on" indication: max. 400mA, reset pb illumination: 2x 180mA
 max. load of relay contacts: 30VDC, 2A
 sound pressure level: internal buzzer 65...80dB(A) adjustable

no.:	type:	description:	weight: [kg]	degree of enclosure	safety distance to magnetic compass [m]:	cable cross-sections:	spare parts:
1	operating device LOD 210.24.0.0	console mounted operating device with blue illuminated display, key switch and rotary encoder with integrated push button, w 144 x h 72 x d 75mm	device: 0,200 cable: 0,300	front: IP22 back: IP00	0,5	/	-
2	connecting module LCM 210.24.0.0	terminal board module, to be mounted on terminal rail TS35, w 162 x h 127 x d 68mm	0,330	IP20	0,5	0,2...1,5mm ²	2x micro fuse, m2,0A, 5x20mm part no.: 097109
3	WAP 220.2.0.0	watch alarm panel for officer's cabin, 80 dB(A) flush mounting	0,150	front: IP23 back: IP00	/	0,2... 2,5mm ²	1x bulb, mg28V, 40mA part no.: 099081
4	WAP 220.4.0.0	watch alarm panel for officer's area (corridor), 64-111dB(A) bulkhead or flush mounting	0,870	IP65	/	0,2... 2,5mm ²	1x bulb, E14, 24V, 4W part no.: 099141
5	WAR 220.1.0.0	watch alarm reset push button, illuminated, connecting type: welding	0,045	IP67	/	0,2... 0,75mm ²	1x bulb, T5,5, 28V, 40mA part no.: 099076
6	WAR 220.1.0.1	watch alarm reset push button, illuminated, connecting type: screws	0,080	IP65	/	0,2... 2,5mm ²	1x bulb, Ba9s, 28V, 45mA part no.: 099083
7	WAB 220.1.0.0	watch alarm wall box with buzzer, 85 dB(A)	0,750	IP65	/	0,2... 2,5mm ²	/
8	WAB 220.2.0.0	external watch alarm buzzer, 85 dB(A) one whole installation, 22,5mm	0,030	IP65	/	0,2... 2,5mm ²	/
9	WAR 220.2.0.0	watch alarm wall box for reset, illuminated	0,750	IP65	/	0,2... 2,5mm ²	1x bulb, T5,5, 28V, 40mA part no.: 099076
10	WAR 220.2.1.0	watch alarm wall box for reset, illuminated with buzzer, 85 dB(A)	0,850	IP65	/	0,2... 2,5mm ²	1x bulb, T5,5, 28V, 40mA part no.: 099076

Bridge Navigational Watch Alarm System sample system

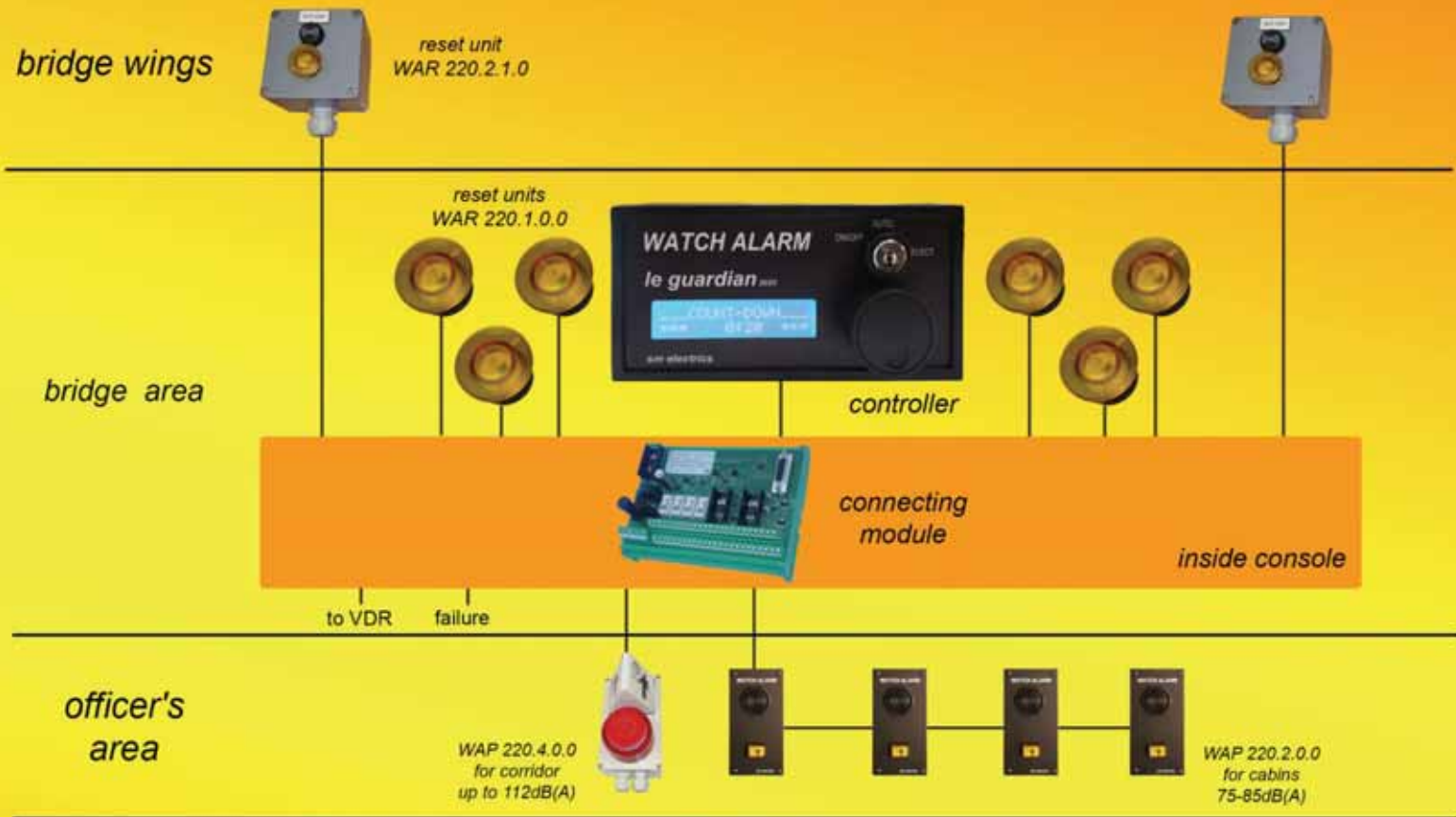

time table

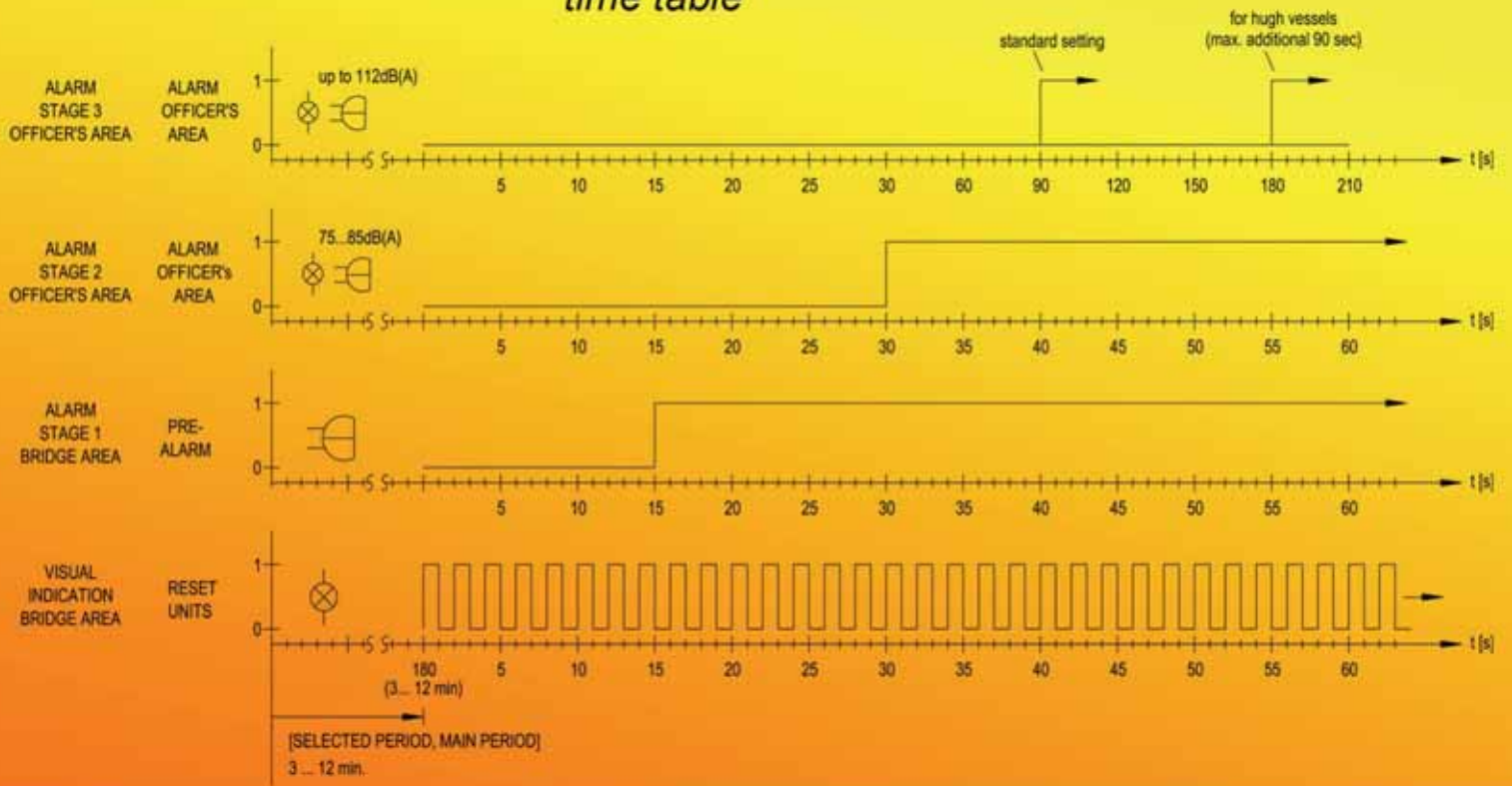

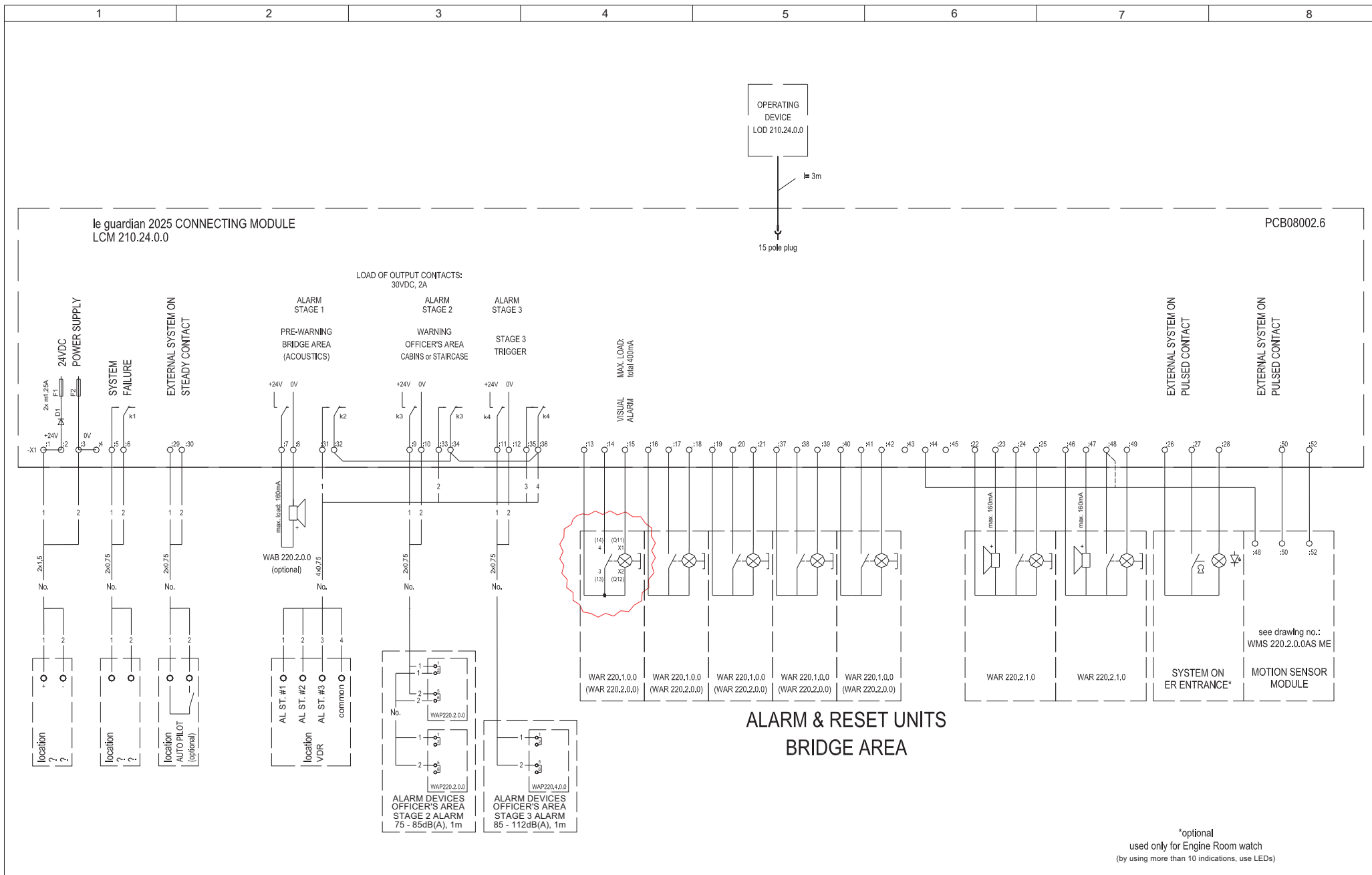

G	power supply qualified	23.3.10	T. Streit	date	23.10.2008	Shipyard	customer	Scale A4	Title: BRIDGE NAVIGATIONAL WATCH ALARM SYSTEM	HULL		-				
F	LINK TO MOTION SENSOR ADDED	18.3.10	T. Streit	former	T. Streit					-						
D	VDR link added	4.3.10	T. Streit	contr.		modification	mess.no	date	name	norm	spare of:	department:	sme	class GL	Drawing No. LCM 210.24.0.0 AS RevG	sh. 1

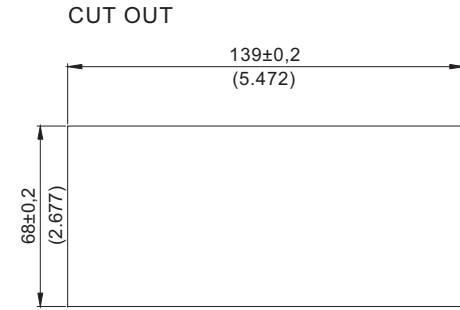
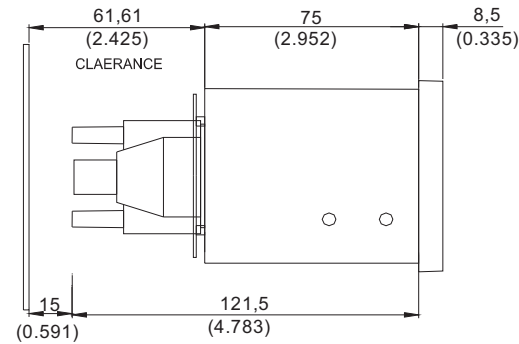
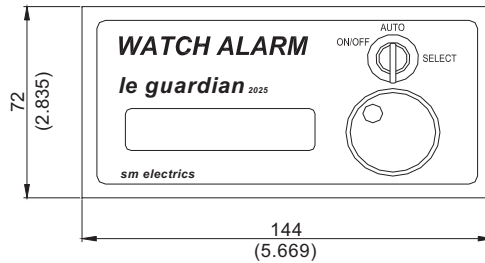

CONSOLE MATERIAL: max. t=8,0mm (0.315)

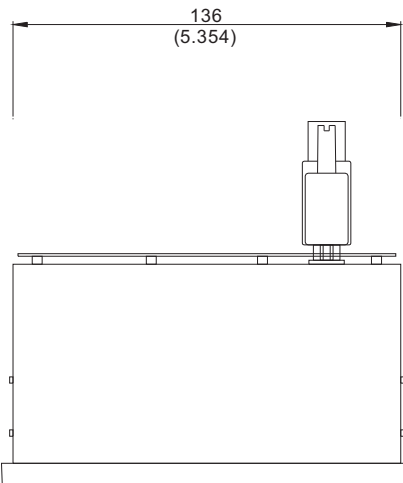

panel surface: black polycarbonat
print: RAL 9010
degree of enclosure, EN 60529: IP22 front sided
evenness of mounting surface < 0,1mm (to keep degree of enclosure)
weight: 0,200kg
power supply: 18,0... 31,2V
power consumption: max. 8,2W, nominal 4,0W

2008	DATUM	NAME	BNWAS OPERATING DEVICE DIMENSIONAL DRAWING	PART No.: -----
BEARB.	22.10.	Streit		mm
GEZ.				(INCH)
GEPRÜFT				
			BNWAS LOD 210 24 0 0 ME AUFTRAG-NR TYP-A/STAND-E ART 2ND	
le guardian 2025 controller DIMENSIONAL				sheet: 1 of: 2

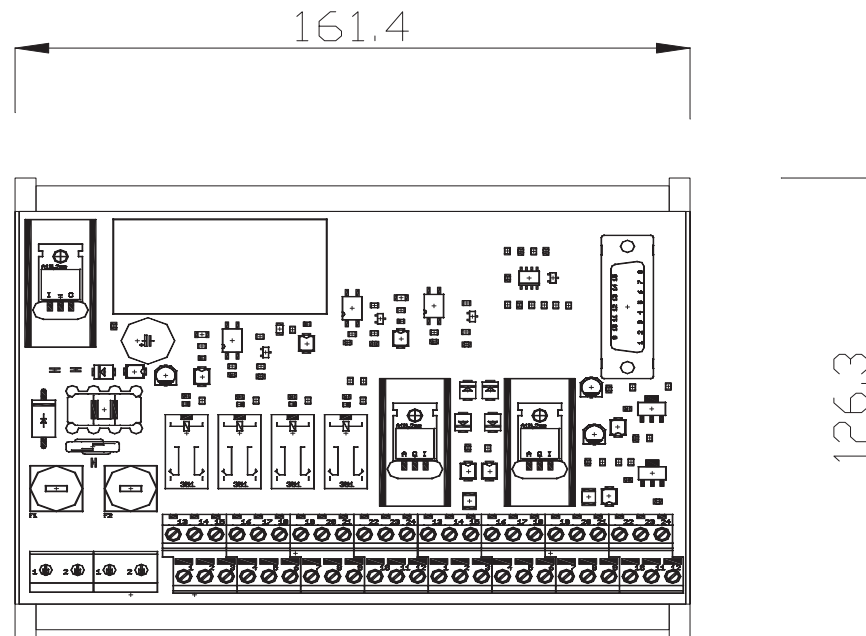

to be mounted on terminal rail TS35
 system voltage: 18,0...31,2VDC, power consumption: 20W
 core size: max 0,2.... 1,5mm, power supply: 0,2.....2,5mm
 degree of enclosure: IP 20
 max. depth: 70mm
 weight: 0,35kg
 safety distance to magnetic compass: 0.5m

				part no.: PCB08002.1		
INDEX	FELD	ÄNDERUNG		ÄND.-MITT.	DATUM	NAME
2008	TAG	NAME				
BEARB.	28.9.	Streit	le guardian 2025 connecting module			
GEPR.						
NORM						
sm electrics & services		BNWAS LCM 210 24 0 0 ME				
		AUFTRAG-NR	TYP-/A/STAND-E	ART	ZND	
				BLATT: 2	VON: 2	

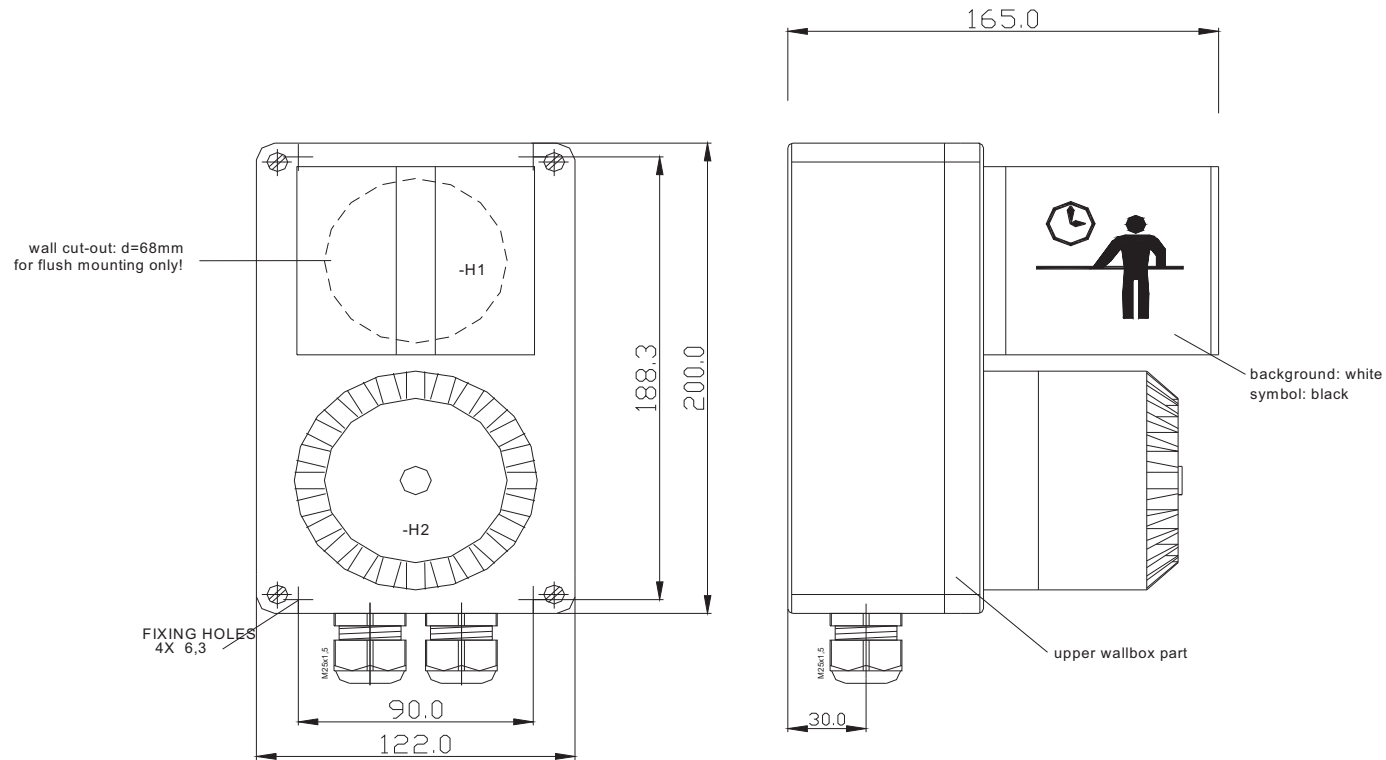

wallbox surface: RAL 7035
nominal values: 24VDC, 350mA
sound pressure level: 64 - 111 db(A) (adjustable)
sound characteristic: 2850 Hz continuous
cable diameter: 8,0 - 16,0mm
core size: max 2,5mm
degree of enclosure: IP 65
depth without lower wall box part: 30mm
bulbs: max. 2x5W
weight: 0,870kg

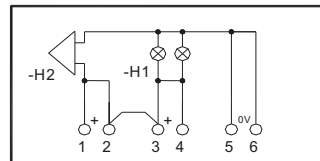

sound code: 11100

2005	DATUM	NAME	PART No.: ?
BEARB.	31.1.	Streit	
GEZ.			
GEPRÜFT			
sm electrics & more			SIGNAL DEVICE WITH SOUNDER & TRIANGLE LIGHT FOR WATCH ALARM
A040080		WAP 220, 4, 0, 0, 0	ME
AUFTRAG-NR		TYP-A/STAND-E	ART AND
BLATT:		VON:	

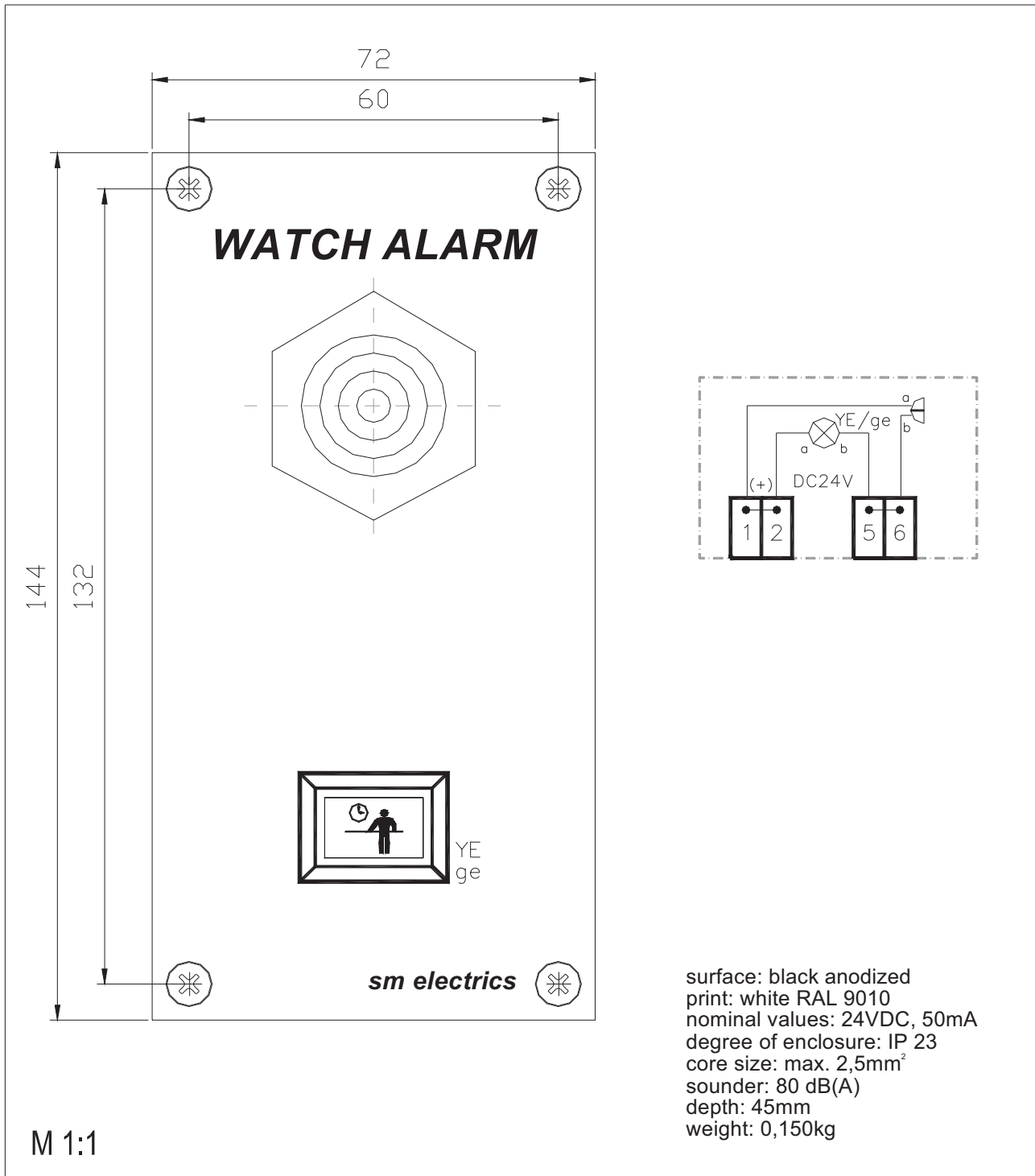

			Teile-Nr.: ?				
INDEX	FELD	ÄNDERUNG			ÄND.-MITT.	DATUM	NAME
2004	TAG	WATCH ALARM PANEL WAP 220.2.0.0					
BEARB	10.12.	for Officer's cabin					
GEPR.							
NORM							
		05AN0000			ME 10		
		AUFTRAG-NR	TYP-A/STAND-E		ART	ŽND	
		standard			BLATT:1	VON: 1	

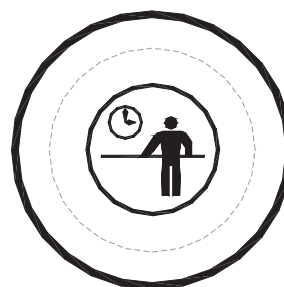
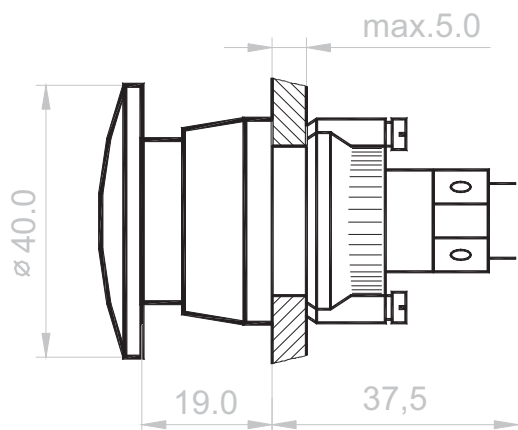

ILLUMINATED PUSH BUTTON

COLOURYELLOW
 ONE-HOLE INSTALLATION..... Ø 22,5mm
 DEGREE OF ENCLOSUREIP67/IEC529
 BULB T5,5-28V-1,2W
 CONTACTS 1NC+1NO-Contact
 CONNECTING TYPE WELDING
 WIRE TYPE 0,2 - 0,75 mm²
 WEIGHT 0,045kg

CONNECTION DIAGRAM

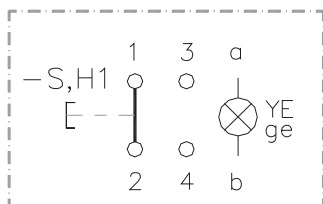

PART No.: 770040

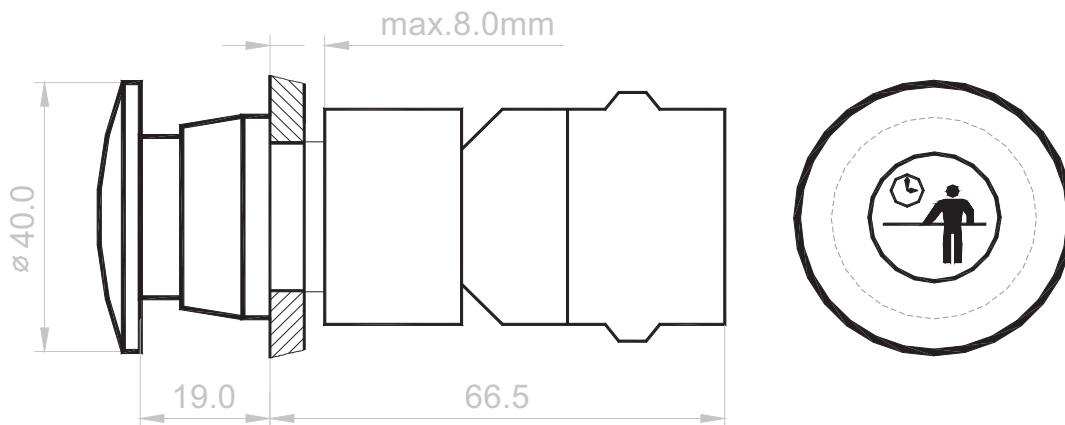

ILLUMINATED PUSH BUTTON

COLOURYELLOW
 ONE-HOLE INSTALLATION Ø 22,5mm
 DEGREE OF ENCLOSUREIP65/IEC529
 BULB Ba9s-28V-1,2W
 CONTACTS 1NO-Contact
 CONNECTING TYPE SCREWS
 WIRE TYPE 0,5 - 1,5 mm²
 WEIGHT 0,080kg

CONNECTION DIAGRAM

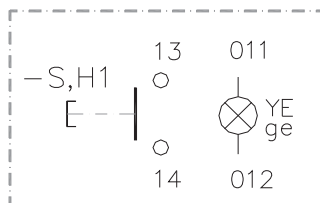

PART No.: 770119

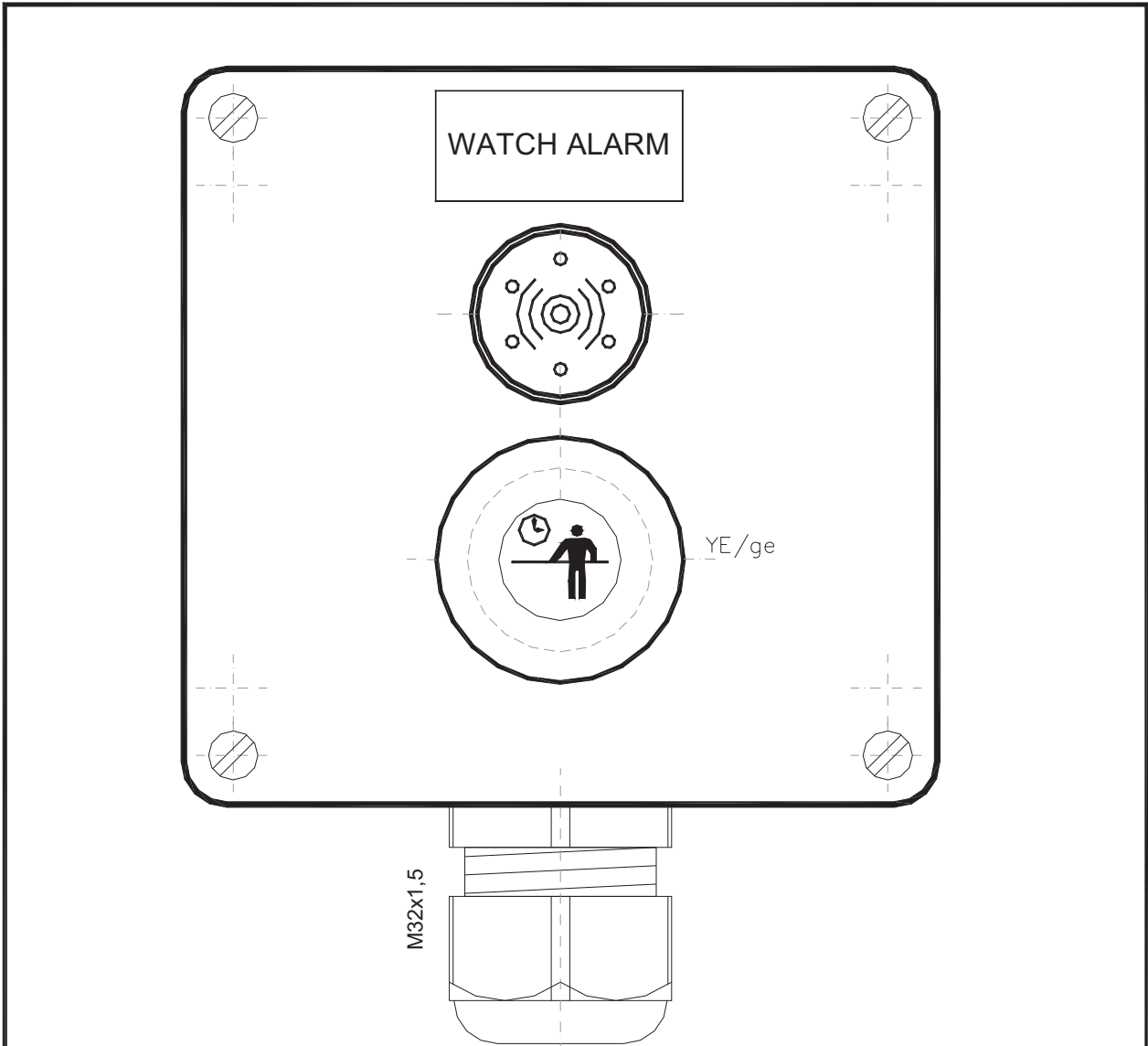

wallbox surface: RAL 7001, depth: 90mm
 nominal values: 24VDC, 50mA
 cable diameter: 9,5 -20,0mm
 core size: max 2,5mm
 degree of enclosure: IP 65
 weight: 0.850kg

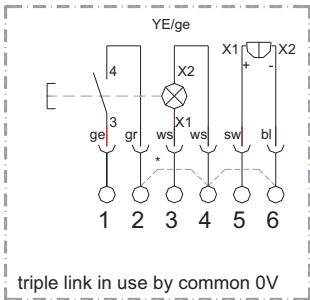

2003	DATUM	NAME	WALL BOX FOR RESET WATCH ALARM	PART No.: 770045	
BEARB.	7.12.	Streit			
GEZ.					
GEPRÜFT					
sm electrics services & more					
			Rev. A: triple link added, 31.7.2009	BLATT:	VON:

FIXING HOLES
4X $\varnothing 6,3$

WATCH ALARM

YE/ge

M32x1,5

106.0
122.0

50.0

82.0
120.0

wallbox surface: RAL 7001, depht: 90mm
nominal values: 24VDC, 40mA
cable diameter: 9,5 - 20,0mm
core size: max 2,5mm²
degree of enclosure: IP 65
weight: 0,750kg

24VDC

gr ge sw X1 X2 bl

1 2 3 4

* link in use by common 0V

2003	DATUM	NAME
BEARB.	7.12.	Streit
GEZ.		
GEPRÜFT		

WALL BOX FOR RESET
WATCH ALARM

PART No.: 770041

sm electrics
& more services

AUFTRAG-NR | WAR 220. 2. 0. 0 | ME | ART ÄND

TYP-A/STAND-E

BLATT: | VON:

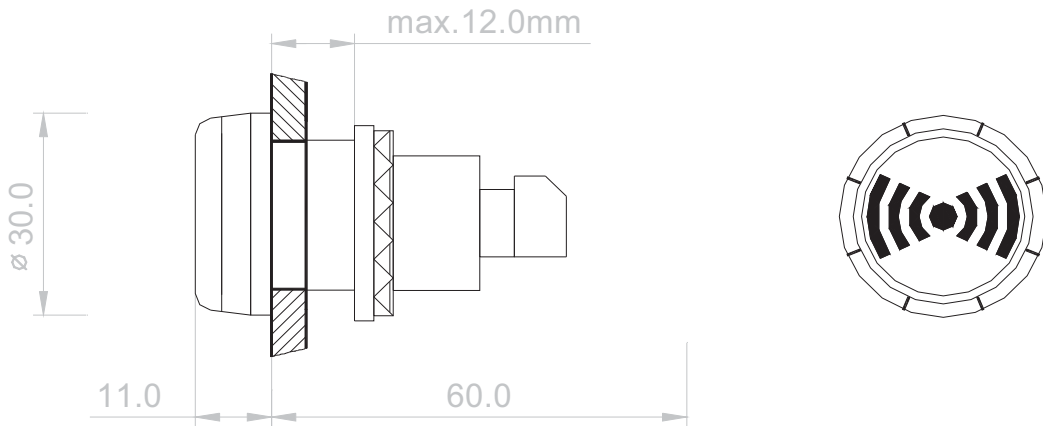

EXTERNAL BUZZER

COLOUR BLACK
 ONE-HOLE INSTALLATION Ø 22,5mm
 DEGREE OF ENCLOSURE IP65/IEC529
 SOUND PRESSURE 85 dB(A)
 CONNECTING TYPE SCREWS
 WIRE TYPE 0,5 – 1,5 mm²
 WEIGHT 0,030kg

CONNECTION DIAGRAM

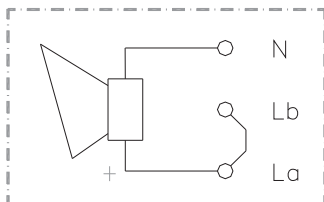

SYSTEM VOLTAGE: 24VDC

PART No.: 770117

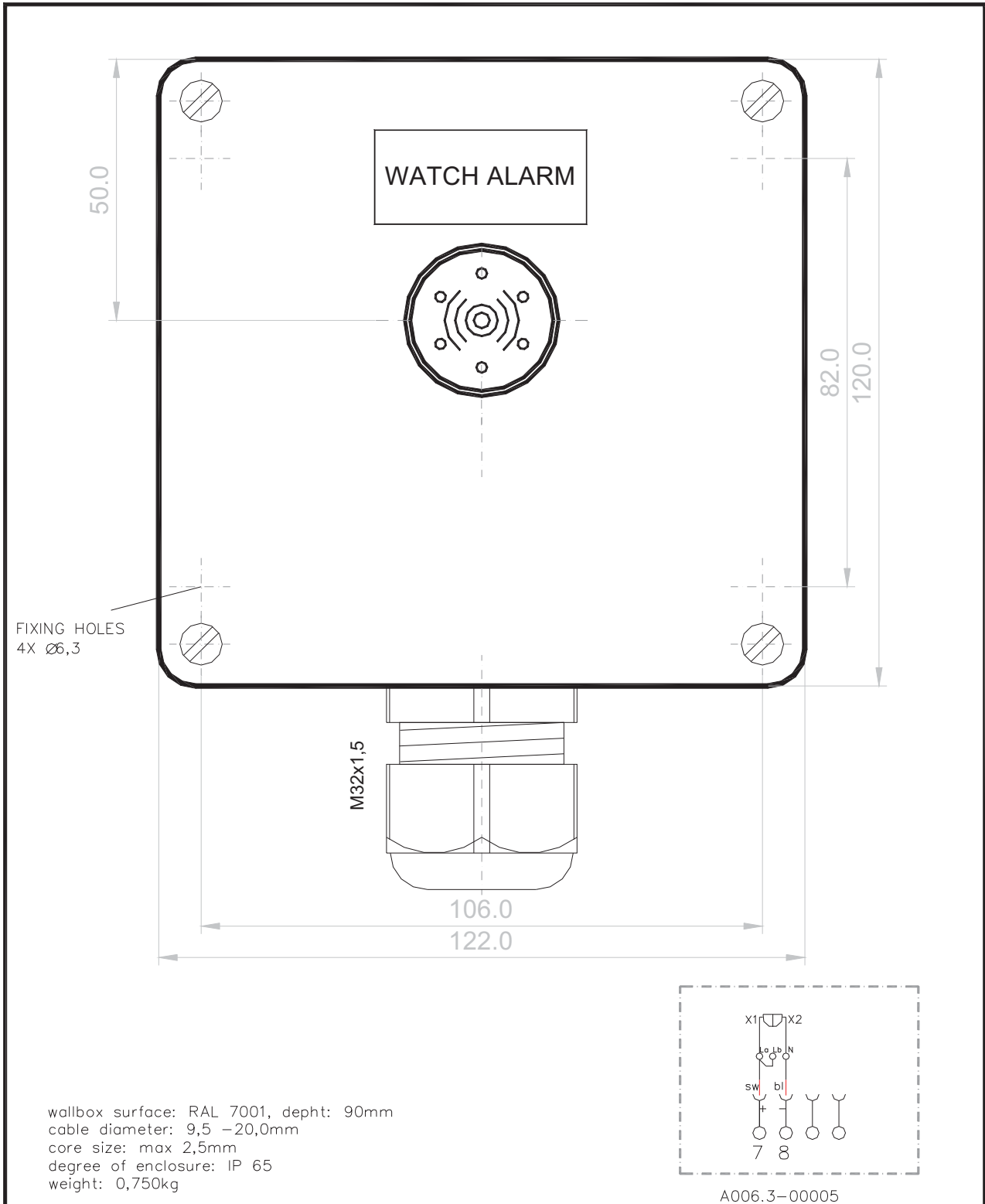

2004	DATUM	NAME	WALL BOX WITH BUZZER FOR WATCH ALARM	PART No.: 770051
BEARB.	1.3.	Streit		
GEZ.				
GEPRÜFT				
				BLATT: VON:

PERSONNEL ALARM
ON / OFF

SYSTEM ON GN/gn

M32x1,5

wallbox surface: RAL 7001, depht: 90mm
cable diameter: 9,5 – 20,0mm
core size: max 2,5mm²
degree of enclosure: IP 65

REV A: nc contact deleted, bulb changed inti LED gn11.5.2009

on / off gn
2 xl (+)
1 x2 (-)
gr ge sw bl
1 2 3 4

2005	DATUM	NAME	SWITCH ON/OFF WALL BOX WATCH ALARM ER (PERSONNEL ALARM)	PART No.: 770043
BEARB.	22.11.	Streit		
GEZ.				
GEPRÜFT				

sm electrics
services & more

AUFTRAG-NR | WAP 222.3.0.0 | ME | A |
TYP-A/STAND-E | ART | ÄND

WAP222.3.0.0 RevA.dwg | BLATT: | VON:

10 user manual short version (for users only)

le guardian 2025 Watch Alarm System acc. MSC .128/75 (Bridge Navigational Watch Alarm System, BNWAS)

- 1.0 Generals
- 1.1 Installation
- 2.1 Manual Switch On
- 2.2 Automatic Switch On
- 3.0 Select dormant (main) period
- 3.1 Reset of dormant (main) period
- 3.2 Alert sequences start automatically
 - 3.2.1 Visual indications
 - 3.2.2 Alarm stage 1
 - 3.2.3 Alarm stage 2
 - 3.2.4 Alarm Stage 3
- 4.1 Emergency Call
- 5.1 System shut-down

1.0 Generals

The purpose of a bridge navigational watch alarm system is to monitor bridge activity and detect operator disability which could lead to marine accidents. The system monitors awareness of the Officer of the Watch (OOW) and automatically alerts the Master or another qualified person if for any reason OOW becomes incapable of performing OOW's duties. This purpose is achieved by series of indications and alarm to alert first the OOW and, if he is not responding, then to alert Master or another qualified person. Additionally, the BNWAS provide the OOW with means of calling for immediate assistance if required.

This user manual (short version) is made for persons who know basic standards of watch alarm system. All time period reset inputs are protected against permanent reset.

1.1 Installation

After operating device LOD 210.24.0.0 and connecting module LCM 210.24.0.0 are installed according to technical documentation by authorized personnel, system has to be supplied by 24VDC battery power supply (terminal board -X1: 1, 3). Potential free n/o failure contact (connecting module -X1: 5, 6) closes and system is ready for switch on. After a short display intro display on operating device is showing "text 1".

display „text 1“

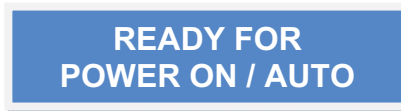

2.1 Manual switch on

Authorized person (Master) switches on system by single turning key switch –S1 on operating device to position "ON/OFF". System's running is indicated by activating last chosen *dormant* (main) period and count-down is active as shown on display "text 2".

display „text 2“



2x16 character
illuminated display



key switch
S1

rotary encodh incl.
push button S2

operating device
LOD 210.24.0.0

If *dormant* (main) period (3... 12 min) shall not be changed, authorized person (Master) pull off the key. *Dormant* period is counting down from the moment that system has been switched on.

Dormant period is period within OOW is monitored but no further alert is triggered.

2.2 Automatically switch on

System can be switched on by external systems via potential free steady n/o contact which has to be connected on connecting module LCM 210.24.0.0 –X1: 29 & 30.

Automatic switch on is possible only in automatic mode - when display is showing “text 1”.

display „text 1“



READY FOR
POWER ON / AUTO

In case automatic switch on shall not be possible, master has to shut-down system (see chapter 5.1 System shut-down)

3.0 Select dormant (main) period

In case that authorized person (Master) demands to select other dormant period, person has to turn key switch S1 on operating device to position “SELECT”. In this position only dormant period can be chosen by using rotary encoder S2 on operating device. Display is showing “text 3”.

display „text 3“



SET MAIN PERIOD:
3... 12min 3 **

By turning rotary encoder S2 in clock wise direction, value is increasing. By tuning rotary encoder S2 in counter clock wise direction, value is decreasing. Possible main period value is limited between 3 and 12 min. Step width is 1 min. By turning key switch S1 into centre position, system accepts new value and count-down starts from the moment the key has turned into centre position. Authorized person (Master) can pull off key only in centre position.

Dormant (main) period (3... 12 min) shows after which period automatically generated alert sequences will be triggered. (see user manual time table, page 20)

3.1 Reset of dormant (main) period

As a rule monitored person (OOW) resets dormant period by pushing illuminating push buttons or rotary encoder’s integrated push button S2 on operating device during his actual work on bridge area. Every reset is re-starting complete count-down independent of its

moment. To serve rules of ergonomics several reset units should be placed on strategic locations on bridge and bridge wing area. These reset units are maximum sized illuminated push buttons as well as loud electronic sounder which have been connected on connecting module LCM 210.24.0.0

3.2 Alert sequences start automatically

3.2.1 visual indications

If dormant (main) period is over without OOW's reset, system activates all illuminated reset units by 1Hz flash light. Display is showing in 1Hz toggle mode display "text 12" and "text 13".

display „text 12“

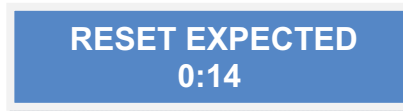

display „text 13“



All illuminated push buttons and display on operating device are centralized dimmable via rotary encoder S2 on operating device. Minimum illumination is fixed.

3.2.2 Alarm stage 1

If dormant (main) period and flash light period (4.2.1, 15 sec) are over without OOW's reset, system activates internal electronic buzzer as well as additional buzzers located on bridge or bridge wing area. Display is showing in 1 Hz toggle mode display "text 14" and "text 15".

display „text 14“

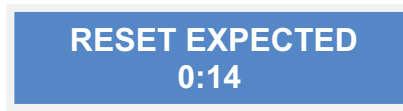

display „text 15“

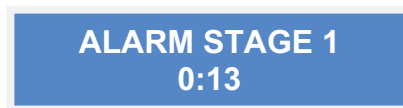

Alarm stage 1 is triggered to pay attention to monitored OOW. Sound characteristics and sound volume are adjustable (see user manual chapter 8). 1 additional potential free (dry) n/o contact is closed now for further use as well as for VDR link. (Additional buzzers or alarm devices can be connected directly on connecting module.)

3.2.3 Alarm stage 2

If dormant (main) period, flash light period (15 sec) and alarm stage 1 (15 sec) are over without OOW's reset, system activates alarm stage 2. Display on operating device is showing in toggle mode display "text 16" and "text 17".

display „text 16“



display „text 17“

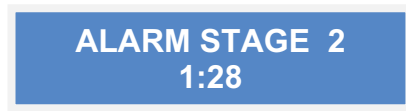

1 additional potential free (dry) n/o contact is closed now for further use as well as for VDR link. (Optic / acoustical alarm devices in officer's area (cabins or staircase) can be connected directly to connecting module.)

3.2.4 Alarm stage 3

If dormant (main) period, flash light period (15 sec), alarm stage 1 (15 sec) and alarm stage 2 (90 sec) are over without OOW's reset, system activates alarm stage 3. Display on operating device is showing in toggle mode display "text 18" and "text 19".

display „text 18“

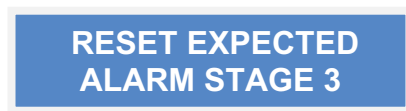

display „text 19“



Two potential free (dry) n/o contacts on connecting module are closed now for alarm stage 3 trigger (very loud alarm devices in officer's area) as well as for VDR link.

4.1 Emergency call

Monitored OOW is able to generate an emergency call...

...by pushing any reset unit longer than 5 sec.

That activates without delay alarm stage 2 and subsequently alarm stage 3 later on.

Display on operating device is showing in toggle mode display "text 20" and "text 21".

display „text 20“



display „text 21“



Notice! Emergency Call feature is not activated when system is shut-down!

see chapter 5.1 System shut-down.

Emergency Call reset is possible by pushing any reset unit longer than 2 sec.

5.1 System shut down

If system is not in operation and external automatic “system on” should not be possible, Master is able to shut down system by turning key switch S2 on operating device for longer than 2 sec to position “ON/OFF”.

Display shuts down and system ignores all external inputs now.

*system is
shut down*

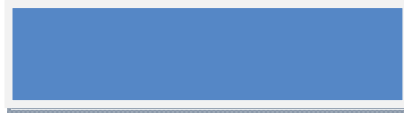

Notice! When system is shut-down no emergency call is possible!

