

Volume

1



User Manual



Flex II Series Controller

EFC202

EFC204

EFC206

EFC208

EVERFOCUS ELECTRONICS CORPORATION

EFC202

EFC204

EFC206

EFC208

Instruction Guide

© 2007~2010 EverFocus Electronics Corp
Room 609, KEMAO Building, Shangdi, Haidian, Beijing, China
Phone 86.10.62973336 • Fax 86.10.62971423

All rights reserved. No part of the contents of this manual may be reproduced or transmitted in any form or by any means without written permission of the EverFocus Electronics Corporation.

Table of Contents

1	Product Overview.....	1
1.1	Features.....	1
1.2	Specifications.....	2
1.3	Parts List.....	3
1.4	Controller Layout.....	4
1.5	Installation Review	5
1.6	Preparation for the Installations.....	6
1.6.1	Obtain a Floor Plan.....	7
1.6.2	Determine Hardware and Location	7
1.6.3	Determine System Structures, Number of Controllers and Modules.....	8
2	Hardware Installation	10
2.1	Mounting the Enclosure and Controller	10
2.2	Installing a Module to Controller	12
2.3	Reader/Door Index Conversion.....	13
2.4	Terminal / LED Definition	14
2.4.1	Main Module Terminal Definition	14
2.4.2	Main Module LED Definition	15
2.4.3	Door Module Terminal Definition	16
2.4.4	Door Module LED Definition	18
2.4.5	Alarm Module Terminal Definition.....	18
2.4.6	Alarm Module LED Definition.....	20

2.5	Install and Connecting the Readers.....	21
2.5.1	RS232 Format	22
2.5.2	Wiegand Format (Self-adaptive)	22
2.6	Connection to Door Lock.....	23
2.6.1	Connection to an Electric Strike.....	23
2.6.2	Connection to a Magnetic Lock.....	24
2.7	Connection to Door Sensor	25
2.8	Connection to Request-to-Exit.....	25
2.9	Connection to Fire & Alarm Input 0.....	26
2.10	Connection to Alarm Input	26
2.11	Connection to Alarm Output.....	27
3	Connecting Controller and Computer	29
3.1	Connection to Computer via RS232	29
3.2	Connection to Desktop Reader via RS485	30
3.3	RS485 Bus Based Networking System	31
3.4	RS485 Bus Extension	31
3.5	Connection to Multiple Controllers via RS485.....	33
3.6	TCP/IP Based System	33
4	Connecting Power.....	35
4.1	Connecting the Power Supply	35

4.2 Mount a Backup Battery (optional)	36
4.3 Connection to Backup Battery	36
4.4 Reset Controller	36
4.5 Cover Placement	37
4.6 Before First Use	37
5 Controller Functionality and Configuration.....	39
5.1 General Operation Guideline.....	39
5.2 Enter System Configuration	39
5.2.1 Display the hardware Version	41
5.2.2 Display the Number of Installed Modules	41
5.2.3 Display the Number of Cards and Events	41
5.3 Main Setting Items	41
5.4 System Setting.....	42
5.4.1 Enter System Setting Menu	42
5.4.2 Set Date Format	42
5.4.3 Set Date.....	43
5.4.4 Set Time	43
5.4.5 Auto Daylight Saving	44
5.4.6 Set System Password.....	44
5.4.7 Set ARM Password.....	45
5.4.8 Set Language	46
5.4.9 Time Server Setting.....	46
5.4.10 Backlight Setting	47
5.4.11 Erase All Events	47

5.4.12	Reset All Data and Setting	47
5.5	Card Setting	48
5.5.1	Enter Card Setting Menu	48
5.5.2	Add Cards	48
5.5.3	Delete Cards	49
5.5.4	Set Card Properties	50
5.5.5	Show Card Number	53
5.6	Door Setting	54
5.6.1	Enter Door Setting Menu	54
5.6.2	Time Zone Setting	54
5.6.3	Set Door Open Mode	55
5.6.4	Open Time Setting	56
5.6.5	Set Door Held Open Time	57
5.7	Reader Setting	57
5.7.1	Enter Reader Setting Menu	58
5.7.2	System Reader Setting	58
5.7.3	Keypad Setting	58
5.7.4	Reader to Door Allocation	59
5.7.5	Reader Input Time Setting	59
5.7.6	Reader Backlight Setting	60
5.7.7	Reader LED or LCD Setting	60
5.7.8	Card Format Setting	60
5.8	Alarm Setting	61
5.8.1	Components for Alarm	61
5.8.2	Alarm Configuration Basics	62
5.8.3	Enter Alarm Setting Menu	62
5.8.4	Alarm Setting Menu Structure	63

5.8.5 Alarm Input Setting	63
Alarm Act Setting on Door Module	65
5.8.6 Event Alarm Output Setting	66
5.9 Address Setting.....	74
5.10 Arm/Disarm	74
5.10.1 Arm the System	74
5.10.2 Disarm the System	75
5.10.3 Reset Alarm	75
5.10.4 Arm/Disarm the System using a Reader.....	76
5.10.5 Arm/Disarm the System using LCD keypad Reader	77
5.10.6 Open door with PIN using keypad Reader.....	77
6 Software Setup	79
6.1 Install the software in the Control Computer.....	79
6.2 Setup the User Accounts for the Software.....	80
6.3 Configure the Controller and All Other Hardware	80
6.3.1 Add a Controller to the System.....	80
6.3.2 Configure the door Settings	80
6.3.3 Configure the Reader Settings.....	81
6.3.4 Configure the Alarm Setting.....	81
6.4 Configure the Holidays, Access Group and Door Control Schedule... 81	
6.4.1 Configure the Holidays	82
6.4.2 Configure the Access Group.....	82
6.4.3 Configure the Door Control Schedule	82
6.5 Enroll Cards	82

1 Product Overview

EverAccess® Flex II Series controller incorporates state-of-the-art technology and modular design to provide reliable performance, user-friendly installation, expansion capabilities, and flexible but powerful configuration options. This controller is the ideal solution for any application that requires electronic access control.

- Powerful management: each controller can be expanded with additional door modules to support up to 8 readers.
- Stand alone or real time PC communication: the controller can operate standalone without a PC connection, or can be managed by the Flex Series software to communicate in real time, sending data to the PC once per second.
- Expandable network: up to 127 controllers can be connected via RS-485 bus or TCP/IP networking (requires additional LAN interface device).
- Easy-to-use: simple configuration operations can be performed at the controller using the integrated keypad.
- Extra alarm module: an additional alarm module can be added to the controller to offer up to 10 alarm inputs and 18 alarm outputs.

1.1 Features

- Modular design, easy-to-expand
- Up to 4 door modules and 8 readers are supported by each controller
- The additional alarm module provides up to 18 alarm signal output interfaces
- Large capacity: 50,000 cards and 170,000 events can be stored in the controller
- Flexible work mode: the controller can operate stand-alone without a PC connection, or can be managed by the Flex Series software to communicate in real time, sending data to the PC once per second via RS-485 or TCP/IP.

- Powerful management capabilities: access can be managed based on time and date, location, cardholder privileges, etc.
- Powerful alarm functions, ability to arm/disarm, specific fire alarm input with corresponding door control, easy connection to alarm panel
- Built-in LCD screen with backlight and keypad allow basic configuration changes at the controller
- Support multiple Wiegand format (self-adaptive) and EverAccess RS232 formats supported
- Built-in transient voltage suppressor (TVS) to protect controller from electric surge

1.2 Specifications

Items	Parameter
Maximum cards	50,000
Maximum records	170,000
Supported readers	2 (expandable up to 8)
Maximum controllers connected via RS485	127, unlimited extending capacity
Controlled Doors	2 (expandable up to 8)
Communication format	Self-adaptive Wiegand format or EverAccess RS-232 format
Cardholder PIN	8 digit
System PIN	8 digit
ARM PIN	8 digit
Alarm input	10 alarm input, each input may be fire alarm
Alarm output	2 alarm outputs on main module, 2 alarm outputs on each door module, 8 alarm outputs on alarm module; Maximum 18alarm outputs with 4 installed door module and 1 alarm module
Communication ports	RS232 or RS485
Band rate	9600 bps
Programmable duration	Maximum 10 per day with minimum duration of 1 min
Programmable date	3 types, up to 384 date in total
Access Schedule	2048
Access group	2048

Multi-Card Access Control	Yes
Card Expiration	Yes
Auto day-light saving	Yes
Anti-passback	Yes
Build-in keypad	4 ×4 keypad
LCD screen	Build-in backlight, support 2×9 Chinese, 2×18 English/Russia, backlight can be set ON or OFF
Real-time clock	Yes
Max current draw for door control relay	5A
Max current draw for alarm relay	2A
Supply voltage	DC 11~16V
Max current	Max 1.5A
Dimension	300mm×216mm×33mm (length×width×height)

1.3 Parts List

Please be careful when you unpack the box due to the electronics devices inside. Check and make sure that you have all the items listed below inside the original box

- 1 EverAccess Flex II Series controller
- 1 controller user manual
- supporting frames (left and right)
- (3mm*6mm) screws (to mount the controller to the frames)

Please Note: If an item appears to have been damaged in shipment, replace it properly in its carton and notify the shipper. If any items are missing, notify your Everfocus Electronics Corp. Sales Representative or Customer Service. The shipping carton is the safest container in which the unit may be transported. Save it for possible future use.

In addition, you may order the following EverAccess products which are recommended for use with the controller to achieve the best performance:

- EverAccess desktop reader (ERU-871)

- EverAccess proximity reader (ERR-871, ERK-871, ERM-871, ERL871)

1.4 Controller Layout

Figure 1.1 shows the layout of the EverAccess Flex Series Controller along with its main components and their functions.

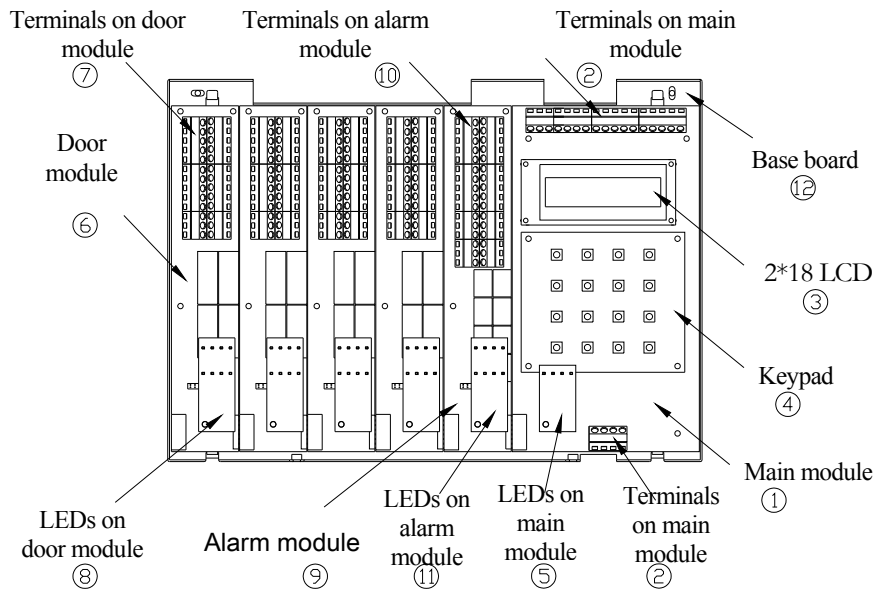

Fig. 1.1 Controller Layout

(1) Main module

The main module controls the fundamental functions of the controller, including the power supply, card and event records, communication via RS232 or RS485 port, 2 alarm input and two alarm outputs. The LCD 3 and keypad 4 provide an interface for the users to directly operate the controller. The main module also controls the door and alarm modules.

(2) Terminals on main module

Please refer to 2.4.1 Main Module Terminal Definition for the definitions and wiring directions.

(3) LCD screen

The LCD screen displays the current status of the controller and the menu. Please refer to Chapter 5 for more details

(4) The keypad

The keypad provides an interface to operate the controller

(5) LEDs on the main module

There are 4 indication LEDs on the controller. Please refer to 2.4.2 Main Module LED Definition for their definitions.

(6) Door module

Each door module controls up to 2 readers, 2 door control relay outputs, 2 alarm outputs, 2 request-to-exit devices and 2 door sensor inputs.

(7) Door module terminals

The door module terminals provide an interface to peripherals like door sensors, door locks, request-to-exit devices and alarm outputs. Please refer to Table 2.3 Door Module Terminal Definition for more details.

(8) Door module LEDs

The LED on the door module shows the status of the door module. Please refer to 2.4.4 Door Module LED Definition for more details.

(9) Alarm module

The alarm module is used to extend the controller's alarm function, adding up to 8 alarm signal inputs and 8 alarm signal outputs.

(10) Alarm module terminals

The alarm module terminals provide an interface to connect the alarm signal input and output devices. Please refer to 2.4.5 Alarm Module Definition for the terminal definitions.

(11) Alarm module LEDs

The LED indicates the alarm status. Please refer to 2.4.6 Alarm Module LED Definition for details.

1.5 Installation Review

This part is focused on the installation process, providing an overall installation plan to help users learn about the planning and final operation of the system. The installation is divided into three steps and detailed description will be covered in the following chapters.

Installation Steps:

The overall installation steps are shown in the following block diagram. The detailed descriptions are given in the subsection below:

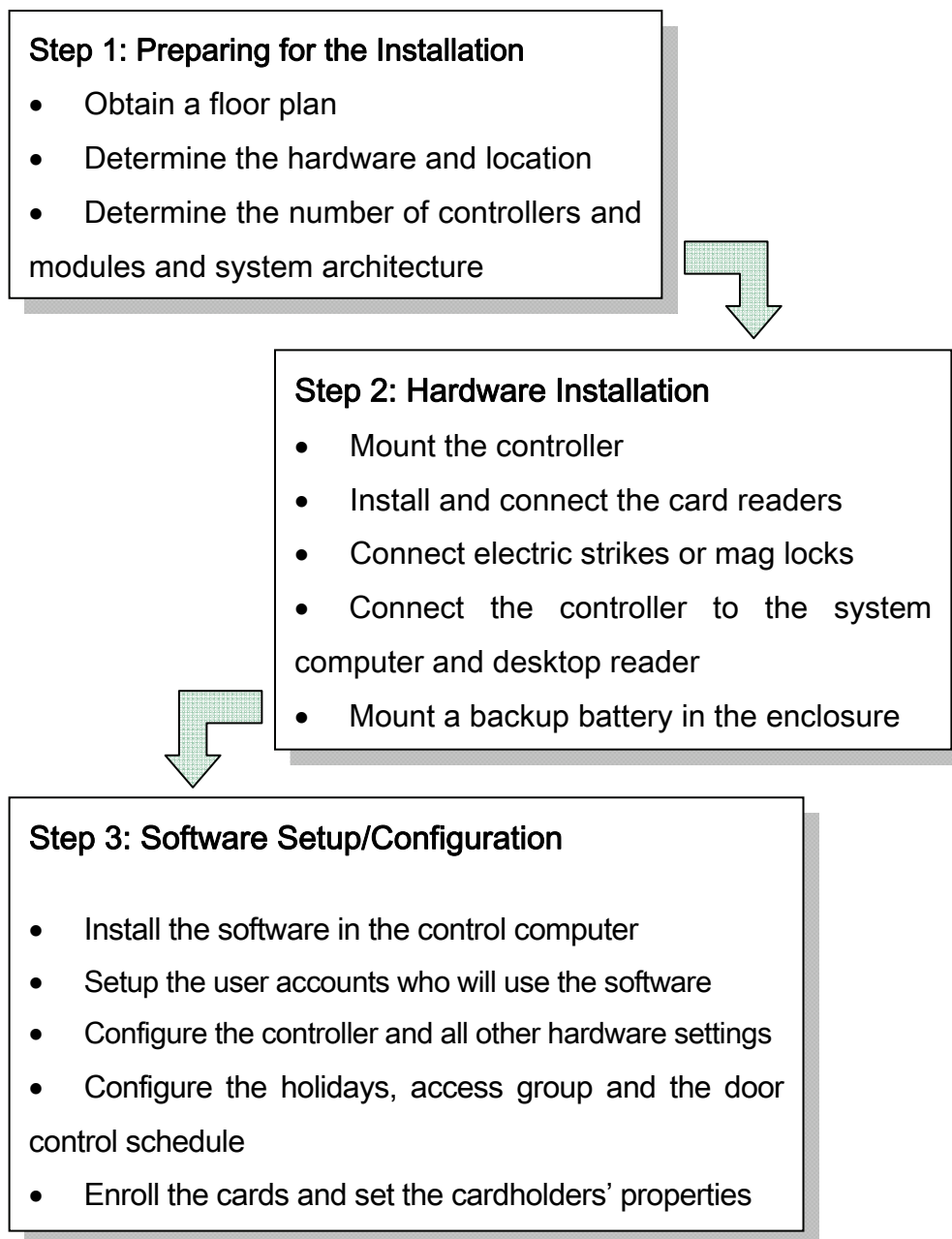

1.6 Preparation for the Installations

Before beginning the installation process, EverAccess recommends that the user properly prepare by gathering certain information. Proper

preparation will help ensure a smooth installation, and will save the installer time and hassle in the long run. The following information is essential for a professional installation:

1.6.1 Obtain a Floor Plan

Obtain a floor plan of the building in which the access control system is to be installed. Obtaining a floor plan helps the installer determine what components need to be installed, and where. It also is essential in determining the length of cable needed to connect readers to the controller. A floor plan can be a blue print of the building, a design, or simply a drawing of the facility. Any document showing the footprint of the building can be used. The dimensions are important to note, especially when determining cable lengths. A floor plan may be obtained from your local city hall.

1.6.2 Determine Hardware and Location

Determining which hardware to use and where it will be installed. This is the most crucial step in the preparation stage. First, determine how many access points, or doors, need to be managed by the access control system. These access points will control the security of the facility, and can limit the entry and exit to and from any given area of the building. After deciding which doors need to be controlled, the user must also determine the level of security needed at each door. There are many ways to manage each door, using different resources. These resources include, but are not limited to: proximal readers, magnetic stripe readers, relays, and request-to-exits. A few common door configurations are described below:

1) One reader, basic access control

The most basic configuration involves one card reader and an electric strike. In this configuration, a person presents a card to the reader, and is either granted or denied access. The electric strike unlocks if the system grants access. In addition, this scenario can monitor whether the door is open, which allows the system to protect against propped open doors, or doors being held open for too long.

2) One reader, with request to exit device

Adding a request to exit device to scenario 1 allows the system to control when to allow people to exit through a door. Request to exit devices include buttons that a person must press in order to exit, or a motion detector that automatically unlocks the door when a person approaches. These devices are always installed on the secure side of the door.

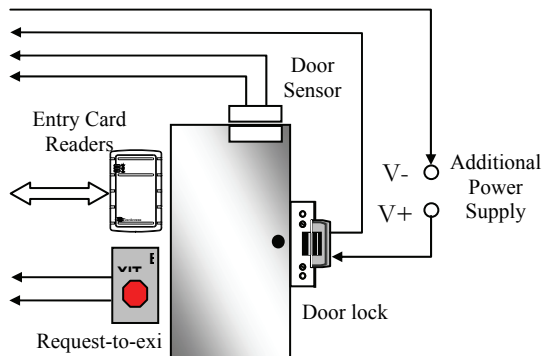

Fig. 1.2 A Common Door Configuration with Entry Reader

3) Two readers, entry and exit access control

If additional security is needed at a particular door, or if the administrator needs a record of the time and date that people enter AND exit a door. Adding a second reader on the secure side of the door will require people to present a card to exit as well as enter. This scenario provides the added security benefit of allowing the system to control who can enter, and who can exit. It also allows the administrator to control when people can enter and exit.

Scenario 1 and 2 require one reader. Scenario 3 requires two. Each door module on the EverAccess Flex II controller can control two readers. Therefore, scenarios 1 and 2 allow one door module to control two doors. Scenario 3 requires one door module for each door. This is important to consider when choosing the appropriate number of modules and readers.

1.6.3 Determine System Structures, Number of Controllers and Modules

User needs to determine how many controllers are needed, and whether an Ethernet interface is required. Each EverAccess Flex II controller can

accommodate up to 8 readers. If the system need to be installed requires more than 8 readers, additional controllers are necessary. These controllers can be connected to the system as described in chapter 3.

If one or more controller is to be installed at a different location than the system computer is to be installed, an Ethernet interface is required to connect over the internet. An Ethernet interface may also be used in locations at which the controllers are installed a long distance away from the system PC. Please refer to chapter 3 for more details on installing the Ethernet interface.

Chapter 2

2 Hardware Installation

In this chapter, after preparing for the installation, the user is ready to begin the install. This section will describe, in general terms, how to install the hardware. Here are the following 5 steps:

- 1) Mount the enclosure (enclosure optional) and controller
- 2) Install and connect the card readers
- 3) Connect the electric strikes or mag locks
- 4) Connect the controller to the system computer and system reader (system reader optional)
- 5) Mount a backup battery in the enclosure (optional)

2.1 Mounting the Enclosure and Controller

The controller is an essential part of the access control system. We recommend mounting it in an EverAccess EPN-871-B metal enclosure (also sometimes referred to as a panel or a can). The controller should be mounted in a location that is convenient and easily accessible, but also secure. The controller acts as the brain of the access control system and can be used to make changes to the database. When choosing a location to mount the controller, choose a clean, dry location that will allow the administrator easy access to make changes to the system, but that can be secured from the general public. The enclosure must be mounted on a sturdy wall using fasteners or anchors (to be provided by the installer). If you are using an EverAccess EPN-871-B metal enclosure there must be an AC power outlet for the enclosure in order to power the controller. (The EverAccess EPN-871-B metal enclosure uses a built in 15 V DC power supply with 110V AC input.) In addition, the system computer should be near the controller, so that the controller can be connected to the PC, allowing the administrator to utilize the Flex Series software. If the system requires additional door or alarm modules, install them in the controller before mounting the controller in the enclosure or on the wall.

Please Note: If the controller screw holes do not line up properly with the enclosure some filing may be needed for adjustment.

The EverAccess Controller package includes two support frames to elevate the controller in order to make wire connections more convenient. The installation is described in the steps below:

Step 1. Mount the two support frames on a wall or on the interior of the EverAccess enclosure. When mounting to a wall, use the mounting template included in the packaging to help position the holes to mount the controller on a wall. If using the EverAccess enclosure, use the four pre-drilled holes on the back wall of the enclosure.

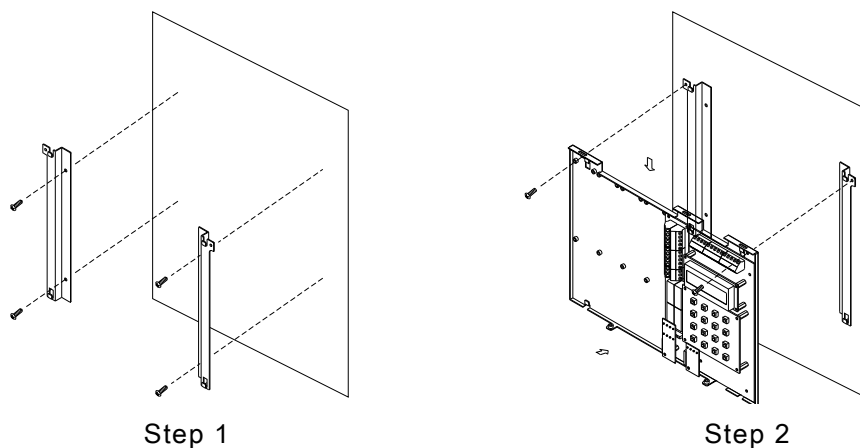

Fig. 2.1 Mounting the Controller Step1 and Step 2

Step 2. Mount the controller base board.

- 1) Place the controller base board on the support frames. Line up the four latches on the support frames with the holes on the controller base board. Once lined up, slide the controller base board down to secure it in place. At this point the two screw holes on the top two corners of the controller base board should be aligned with the corresponding holes on the support frame.
- 2) Secure the controller base board to the support frames with the two screws (provided in the controller package).

Step 3. Install and mount additional door modules or the alarm module

- 1) Connect the pins on the lower right corner of the new module to the connector on the bottom left corner of the installed module. Make sure that the pins fit snugly into the receiving module.
- 2) Secure the module to the controller base board using the three screws (provided in the module package)

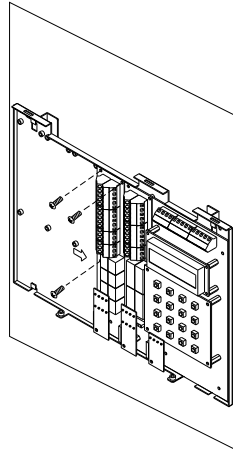

Fig 2.2 Mounting the Controller Step 3

2.2 Installing a Module to Controller

EverAccess Flex II series controller can hook up to 4 door modules and 1 alarm module. Please note only ONE alarm module can be installed to the controller. Each door module is cascaded to its left side module till the main module. The door modules and the alarm module can be placed in any sequence. The index will follow the same rules (refer to next subsection). The steps to install a new module are described below:

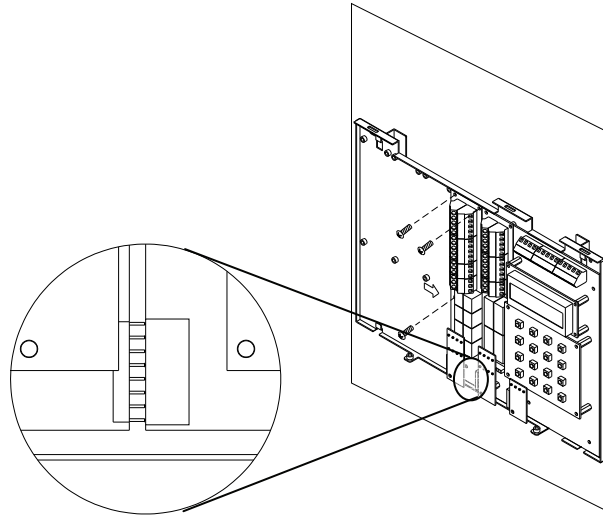

Fig. 2.3 Install a New Module to Controller

- 1) Connect the pins on the lower right corner of the new module to the connector on the bottom left corner of the installed module. Make sure that the pins fit snugly into the receiving module.
- 2) Secure the module to the controller base-board using the three screws (provided in the module package).

2.3 Reader/Door Index Conversion

One EverAccess Flex II Series controller can accommodate up to 4 door modules, each of which controls 2 readers. The index conversion of readers and is displayed below. The readers/doors are counted 1 to 8 from right to left.

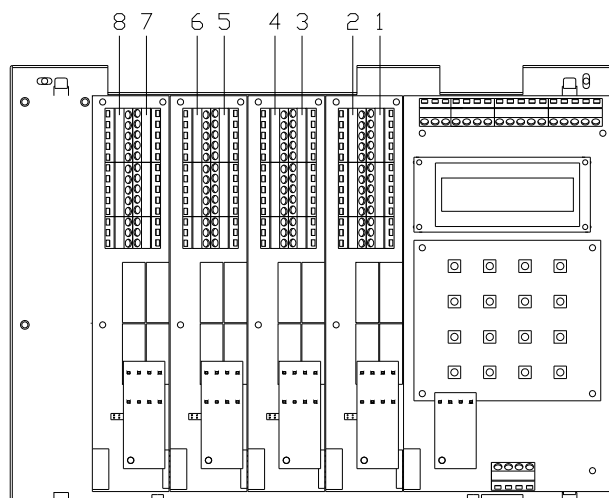

Fig. 2.4 Reader/Door Index Conversions

Please Note: Each card reader can be associated with any door index. Please refer to Chapter 5 for more details.

2.4 Terminal / LED Definition

2.4.1 Main Module Terminal Definition

There are 21 terminals are located on the main module, as shown in Fig. 2.5:

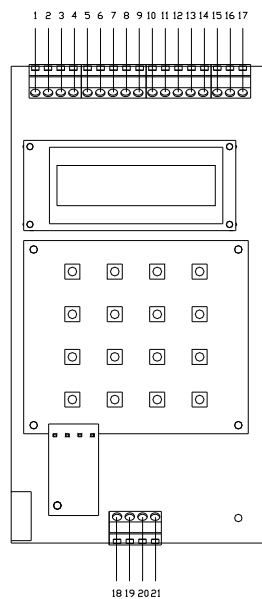

Fig. 2.5 Main module and its terminals

The terminal definitions are shown in the following table:

Table 2.1 The Definition of the Main Module Terminals

NO	Terminal name	Function
1	Alarm input 0	Alarm Input 0
2	GND	Alarm Input ground
3	Alarm input 1	Alarm Input 1
4	AUXAlarmOutNo	Normally open pin of auxiliary alarm output
5	AUXAlarmOutCom	Common pin of auxiliary alarm output
6	AUXAlarmOutNC	Normally close pin of auxiliary alarm output
7	MainAlarmOutNo	Normally open pin of main alarm output

8	MainAlarmOutCOM	Common pin of main alarm output
9	MainAlarmOutNC	Normally close pin of main alarm output
10	NC	No connection/reserved
11	NC	No connection/reserved
12	COMM_GND	GND of RS485 and RS323
13	RS232_RXD	RXD of RS323 (Receiving)
14	RS232_TXD	TXD of RS323 (Transmitting)
15	RS485_A	Signal A of RS485 bus
16	COMM_GND	GND of RS485 and RS323
17	RS485_B	Signal B of RS485 bus
18	Power	Power input
19	GND	Power ground
20	BATT+	Battery positive pin
21	BATT-	Battery negative pin

2.4.2 Main Module LED Definition

There are 4 LEDs on the main module. The position and index are defined in Fig. 2.6 and table 2.2. :

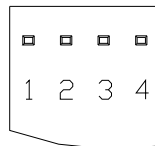

Fig. 2.6 Main Module LED Definition

Table 2.2 The definition of the LEDs on the main module

LED	Meaning
1	ON indicates the power is on
2	On indicates fire alarm armed, flash indicates fire alarm input
3	Flash indicates receiving
4	Flash indicates transmitting data

2.4.3 Door Module Terminal Definition

The terminals on the door modules are classified into two groups, each of which controls two doors and the corresponding readers. The right side terminals (indexed from #1~#16) control one reader, while the left side terminals (indexed from #17~#32) are responsible for the 2nd reader, as shown in Fig. 2.7. As described in the “reader/door index conversion” section of the manual, the reader’s index depends on the door module to which it is connected. For example, consider one door module where terminals #1 ~#16 control Reader 1, and #17~#32 control Reader 2. Table 2.3 shows the definition and wiring details for the door module terminals. The definitions of the door module terminals are defined in the table 2.3.

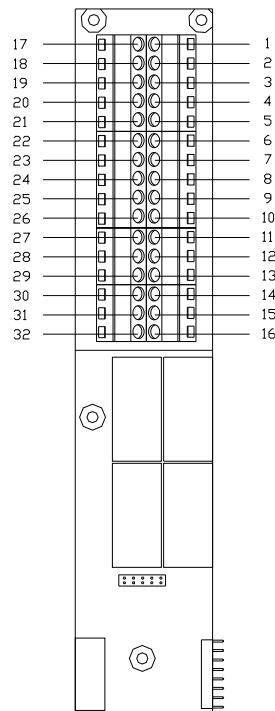

Fig. 2.7 Door Module Terminal Definition

Table 2.3 The Definitions of the Door Module Terminals

No.	Terminal name	Function
1	Reader1_Data0	Reader 1 Wiegand Data 0
2	Reader1_Data1	Reader 1 Wiegand Data 1
3	Reader1_DC	Power supply for reader 1. Output +12V voltage
4	Reader1_GND	Ground for reader 1
5	Reader1_Ctrl	Control line for reader 1
6	RX_1	Port to TX signal to reader 1
7	TX_1	Port to RX signal to reader 1
8	Door1_Button	The request-to-exit button for door 1
9	Door1_GND	Ground for terminal 8&10
10	Door1_Sensor	Door sensor input for door 1
11	Door1_NO	Normally open pin for door control relay 1
12	Door1_COM	Common pin for door control relay 1
13	Door1_NC	Normally close pin for door control relay 1
14	Alarm1_NO	Normally open pin for alarm output relay 1
15	Alarm1_COM	Common pin for alarm output relay 1
16	Alarm1_NC	Normally close pin for alarm output relay 1
17	Reader2_Data0	Reader 2 Wiegand data 0
18	Reader2_Data1	Reader 2 Wiegand data 1
19	Reader2_DC	Power supply for reader 2, output +12V voltage
20	Reader2_GND	Ground for reader 2
21	Reader2_Ctrl	Control line for reader 2
22	RX_2	Port to TX signal to reader 2
23	TX_2	Port to RX signal to reader 2
24	Door2_Button	The request-to-exit button for door 2
25	Door2_GND	Ground for terminal 24 & 26
26	Door2_Sensor	Door sensor input for door 2
27	Door2_NO	Normally open pin for door control relay 2
28	Door2_COM	Common pin for door control relay 2
29	Door2_NC	Normally close pin for door control relay 2
30	Alarm2_NO	Normally open pin for alarm output relay 2
31	Alarm2_COM	Common pin for alarm output relay 2
32	Alarm2_NC	Normally close pin for alarm output relay 2

2.4.4 Door Module LED Definition

There are 8 LED indicators on each door module. The positions and indexes are shown in Fig. 2.8. The definitions of these LED indicators are presented in Table 2.4

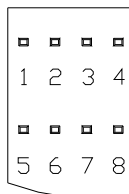

Fig. 2.8 Door Module LED Definition

The definitions of LEDs on the door module are defined in the following table:

Table 2.4 The Definition of LEDs on the Door Module

LED	Meaning
1	Flash indicates the alarm relay #2 is energized
2	On indicates reader #2 connected
3	On indicates the door sensor #2 is off (the door is open)
4	On indicates door control relay #2 energized
5	Flash indicates the alarm relay #1 is energized
6	On indicates reader #1 connected
7	On indicates the door sensor #1 is off (the door is open)
8	On indicates door control relay #1 energized

2.4.5 Alarm Module Terminal Definition

There are 36 terminals on the alarm module. The positions and indexes are described in Fig 2.9. The definitions are described in Table 2.5.

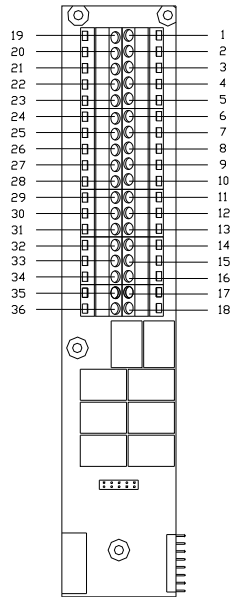

Fig. 2.9 Alarm Module Terminal Definition

Table 2.5 The Definition of Terminals on the Alarm Module

No.	Terminal name	Function
1	Alarm2_In	Alarm signal input 2
2	GND	Ground
3	Alarm3_In	Alarm signal input 3
4	Alarm4_In	Alarm signal input 4
5	GND	Ground
6	Alarm5_In	Alarm signal input 4
7	Alarm1_NO	Alarm 1 output for normally-open
8	Alarm1_COM	Alarm 1 output in common
9	Alarm1_NC	Alarm 1 output for normally-close
10	Alarm2_NO	Alarm 2 output for normally-open
11	Alarm2_COM	Alarm 2 output in common
12	Alarm2_NC	Alarm 2 output for normally-close
13	Alarm3_NO	Alarm 3 output for normally-open
14	Alarm3_COM	Alarm 3 output in common
15	Alarm3_NC	Alarm 3 output for normally-close
16	Alarm4_NO	Alarm 4 output for normally-open
17	Alarm4_COM	Alarm 4 output in common
18	Alarm4_NC	Alarm 4 output for normally-close

19	Alarm6_In	Alarm signal input 6
20	GND	Ground
21	Alarm7_In	Alarm signal input 7
22	Alarm8_In	Alarm signal input 8
23	GND	Ground
24	Alarm9_In	Alarm signal input 9
25	Alarm5_NO	Alarm 5 output for normally-open
26	Alarm5_COM	Alarm 5 output in common
27	Alarm5_NC	Alarm 5 output for normally-close
28	Alarm6_NO	Alarm 6 output for normally-open
29	Alarm6_COM	Alarm 6 output in common
30	Alarm6_NC	Alarm 6 output for normally-close
31	Alarm7_NO	Alarm 7 output for normally-open
32	Alarm7_COM	Alarm 7 output in common
33	Alarm7_NC	Alarm 7 output for normally-close
34	Alarm8_NO	Alarm 8 output for normally-open
35	Alarm8_COM	Alarm 8 output in common
36	Alarm8_NC	Alarm 8 output for normally-close

2.4.6 Alarm Module LED Definition

There are 8 LED indicators on each Alarm module. The positions and indexes are shown in Fig. 2.10. The definitions of the LED indicators are presented in Table 2.6.

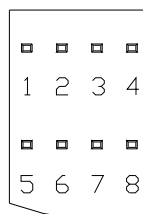

Fig. 2.10 Alarm Module LED Definition

Table 2.6 The Definition of the LED Indication on the Alarm Module

LED	Meaning	LED	Meaning
1	Alarm signal input 2	5	Alarm signal input 6

2	Alarm signal input 3	6	Alarm signal input 7
3	Alarm signal input 4	7	Alarm signal input 8
4	Alarm signal input 5	8	Alarm signal input 9

The alarm LED has four different indications:

Light flashes quickly: The alarmed zone is in danger; alarm signal is input:

- Light off: No alarm alert for the alarmed zone.
- Light flashes slowly: The alarmed zone is in the alert delay stage.
- Solid light on: The alarm alert is on for the alarmed zone
- Light flashes quickly: The armed zone is in danger; there is alarm signal input

2.5 Install and Connecting the Readers

The card readers chosen for the access control system must be mounted near each door and connected directly to the door module(s) in the controller. Each module can accommodate two readers. The general procedure is described below:

- 1) Mount each reader, following the instructions included with the reader. Typically, this will include drilling two holes in the mounting wall, and then using the reader mounting hardware to secure the reader to the mounting wall.
- 2) Once the readers are mounted, connect them to the door module. For wiring definitions, please see previous sections in this manual.

As mentioned before, every door module can control up to two card readers with the correct wiring. The supported reader formats are EverAccess RS232 and Wiegand format. For instructions on connecting each type, please refer to Fig. 2.11 for the RS232 reader connection and Fig 2.12 for the Wiegand reader connection. (The terminals for the 2nd side of the door module are given in brackets)

2.5.1 RS232 Format

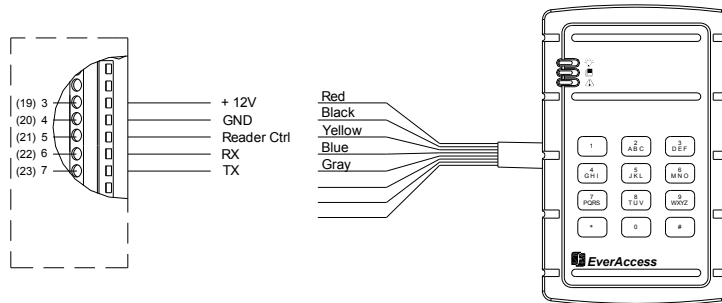

Fig. 2.11 Connection to the EverAccess Reader using RS232 Format

Numbers 19~23 signifies Reader 2 and 3~7 Signify Reader 1 Connections.

2.5.2 Wiegand Format (Self-adaptive)

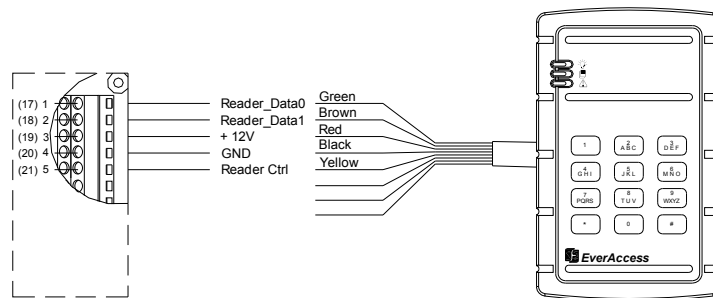

Fig. 2.12 Connection to the EverAccess Reader using Wiegand Format

Numbers 19~21 signifies Reader 2 and 1~5 Signify Reader 1 Connections. The controller will automatically adjust to the Wiegand format of the card reader.

Each door module can provide +12V voltage for two card readers. Twisted cable is recommended to connect the controller and card readers. The maximum transmission distance between the reader and controller depends on the gauge of the cable and the specification of the card reader. Please read the reader user manual carefully before installing the cable for the readers.

Please Note: When installing a multi-reader system, it is strongly recommended that all the card readers follow the same format, i.e. all of them are EverAccess RS232 or Wiegand. Multiple formats could present compatibility problems: a card may not be accepted by all the card readers in the system.

2.6 Connection to Door Lock

Electric strikes and magnetic locks are used to keep doors locked unless the system grants access or the user sets the doors to remain unlocked. The installer must supply the electric strikes and/or magnetic locks. It is recommended that the installer follow and keep the instructions for these locks. One strike or mag lock is required for each door. These locks must be powered separately from the readers. The mounting instructions for strikes and mag locks vary depending on the manufacturer and type of lock. Please consult the instructions included with the door hardware when installing. Once the locks are installed, follow the instructions below to connect them to the controller.

Each door module provides an interface to two door control relays. Terminals 11~13 are for door 1 connections and terminals 27~29 are for door 2 connections. Terminals 12 and 28 are named common terminals (COM). Terminals 13 and 29 are used for normally closed terminal (N.C.) locks. Terminals 11 and 27 are used for normally open terminal (N.O.) locks.

The electrical door lock must have a separate power supply. The power supply for the electrical door lock depends on the specification of the lock. Carefully choose the cable connecting the door locks to fit the current draw. Two common types of electrical door locks in the market are electric strike locks and magnetic locks. The connection methods for these examples are shown in Fig. 2.13 and 2.14 respectively.

2.6.1 Connection to an Electric Strike

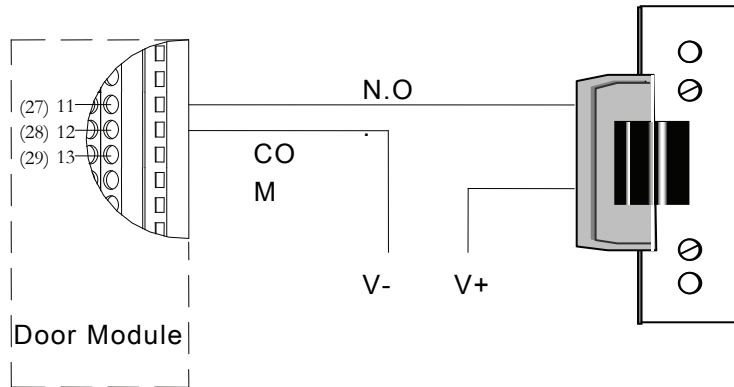

Fig.2.13 Example for Connecting an Electric Strike

Terminals 11~13 are for Door 1 and terminals 27~29 are for Door 2 connections.

2.6.2 Connection to a Magnetic Lock

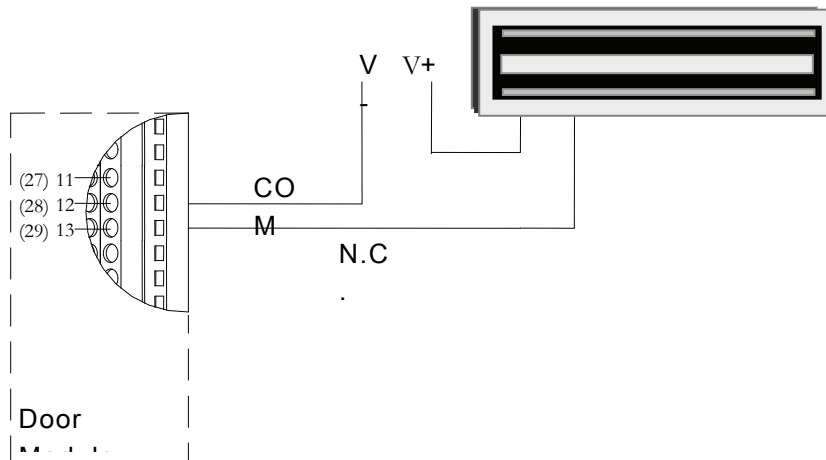

Fig. 2.14 Example for Connecting a Magnetic Lock

Terminals 11 ~13 are for Door 1 and terminals 27~29 are for Door 2 connections.

Please NOTE: The maximum current outputted by the door lock relay on the door module is less than 5A. If the current for door lock exceeds the capacity, an external power relay is needed.

V+ in the figures represents one lead of power from an external power source. When using DC Voltage for the lock, put the positive lead here. When using AC the leads are interchangeable.

2.7 Connection to Door Sensor

The interface to the door sensor is also provided by the door module: door sensor 1 corresponds to terminal 9-10 and corresponds to 25-26 on the door module.

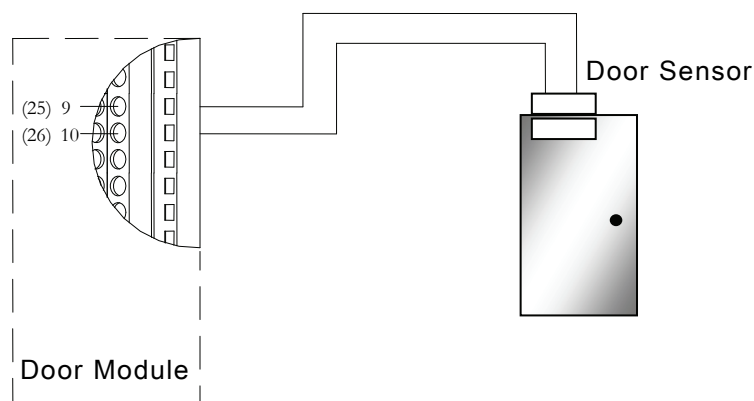

Fig. 2.15 Example for Connecting Door Sensor to Controller

Terminals 9 ~10 are for Door 1 and terminals 25~26 are for Door 2 connections.

NOTE: Among these four terminals, terminal 9 and 25 are GND, shared by the door sensor and request-to exit.

2.8 Connection to Request-to-Exit

The door module also provides an interface to the request-to-exit button or sensor: door 1 is connected to terminals 8-9 and door 2 is connected to terminals 24-25 respectively.

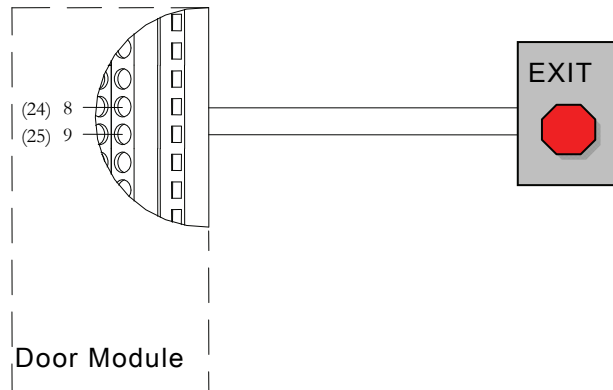

Fig. 2.16 Connecting Request-to-Exit to Controller

Terminals 8 ~9 are for Door 1 and terminals 24~25 are for Door 2 connections.

NOTE: Among these four terminals, terminal 9 and 25 are GND, shared by the door sensor and request-to exit (8 and 24 are your input signals).

2.9 Connection to Fire & Alarm Input 0

The main module provides fire alarm input and one general alarm input (alarm input 1), connecting to terminal 2, 3 and 1, 2 respectively. The GND (terminal 2) is shared by these two input signals.

2.10 Connection to Alarm Input

The alarm signals other than the fire alarm and alarm input 1 are controlled by the alarm module, which contains 8 alarm inputs and 8 alarm outputs. Using the 6th channel alarm signal input as an example, the method to connect the alarm module to the alarm sensor is shown in Fig. 2.17:

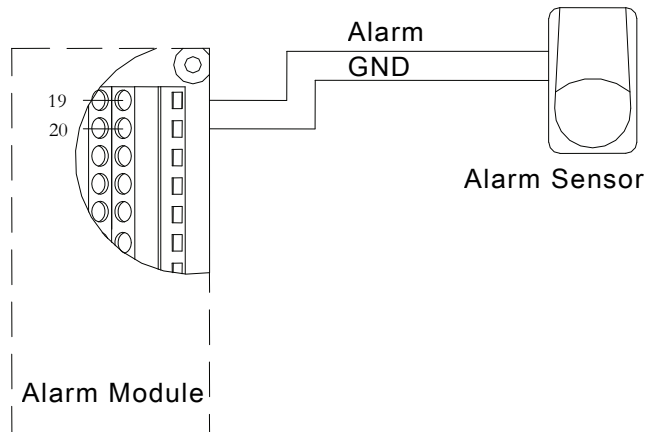

Fig.2.17 Connecting Alarm-sensor to Controller

2.11 Connection to Alarm Output

The alarm module provides 8 alarm inputs and 8 alarm outputs. The user can assign the corresponding relay status to the different events. There are three terminals: COM, N.O and N.C. The wiring depends on the alarm device. Please read the user manual of the external alarm devices before wiring. Using the 5th channel alarm signal output as an example, the wiring is shown in Fig. 2.18 and Fig.2.19.

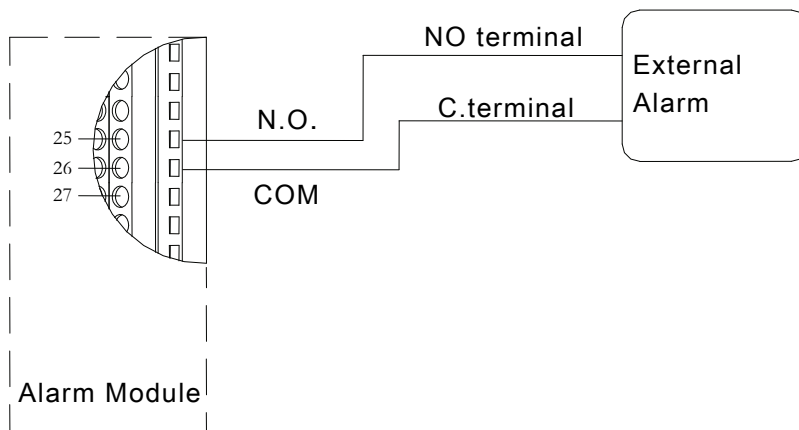

Fig. 2.18 Normally Open Connection for Alarm Output 5

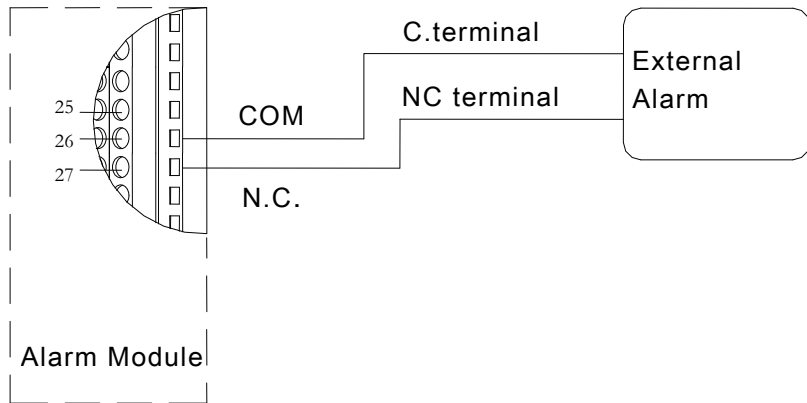

Fig. 2.19 Normally Closed Connection for Alarm Output 5

3 Connecting Controller and Computer

3.1 Connection to Computer via RS232

The EverAccess Flex II controller is able to operate as a stand-alone device or as a networked device, connected directly to a PC via serial port.

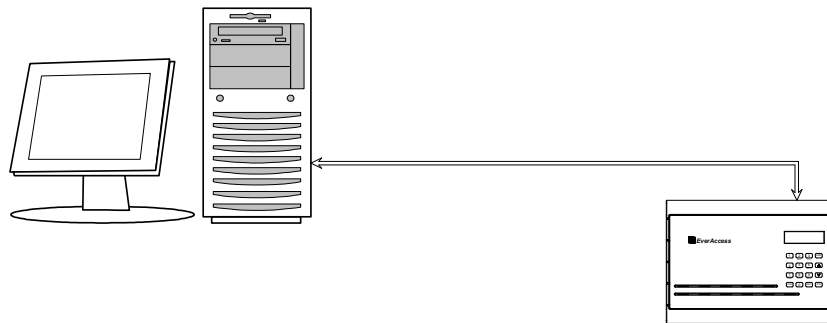

Fig. 3.1 Connecting the Controller to a PC

To connect the controller to the computer via RS232, the communication terminals should be wired to the computer serial port as follows: the RS232 TX terminal of the controller is linked to the RS232 RX of the serial port and the RS232 RX terminal is linked to the TX terminal of the computer; The ground terminal GND-S is linked to the computer ground terminal.

If the controller is installed in the EverAccess enclosure, the DB9 serial port interface makes the connection even easier. Fig. 3.2 describes how to connect the DB9 port to the computer serial port. If a self-made cable and interface is used for connection, then a DB9 female connector is required. The terminal 12, 13 and 14 on the main module should be linked to the pin 5, 3 and 2 respectively, which are GND, TXD and RX.D.

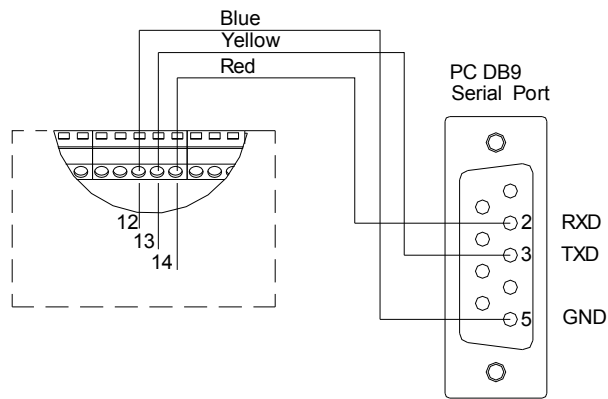

Fig. 3.2 Connection to Computer via RS232

3.2 Connection to Desktop Reader via RS485

To connect the EverAccess Flex Series controller to the desktop reader via RS485 bus, terminal 15, 16 and 17 on the main module should be wired to the line 2, 3 and 1 in RJ45 head respectively (i.e. terminal 17 is wired to line 1, terminal 15 is wired to line 2 and terminal 16 is wired to line3), as Fig. 3.3 shows.

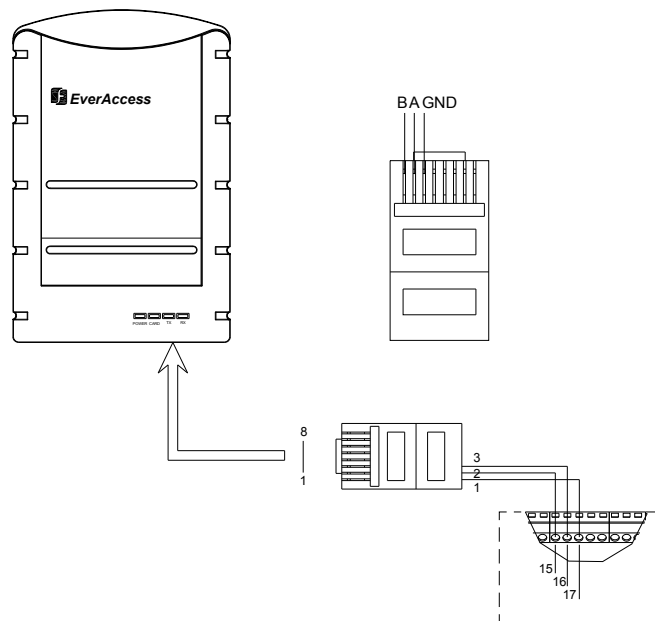

Fig. 3.3 Connection to Desktop Reader via RS485

3.3 RS485 Bus Based Networking System

Multiple EverAccess Flex II controllers can be connected to accommodate larger access control systems. The controllers are connected via RS485, as shown in Fig. 3.4. The desktop reader (Part#: ERS-871) is a critical component of an RS485 bus based system: it allows simple card enrollment and acts as the interface between multiple controllers and the PC.

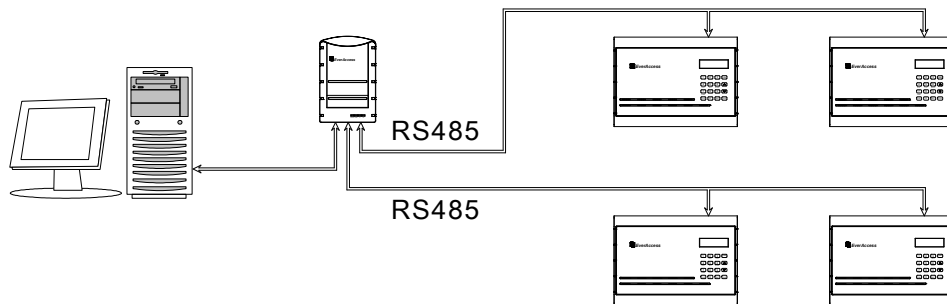

Fig. 3.4 Connections of Multiple Controllers

A brief overview of the installation:

- 1) Connect the EverAccess desktop reader to the computer via USB port.
- 2) Connect one or two controllers to the desktop reader via RJ45 port.
- 3) More controllers can be connected to each controller by RS485 bus.

3.4 RS485 Bus Extension

You can connect the controllers to each other using an RJ45 network cable. Simply use wires 3, 2, and 1 as shown in Fig. 3.5.

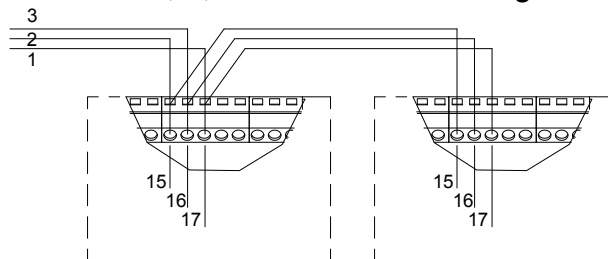

Fig. 3.5 Connection to Multiple Controllers via RS485

In order to correctly transfer data, the controllers on the RS485 bus must be connected in a daisy chain format, as shown in Fig. 3.6.

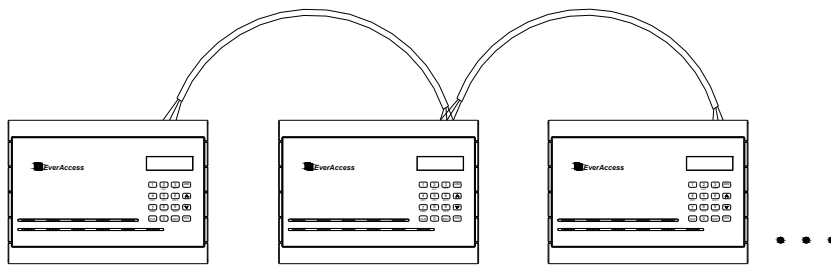

Fig. 3.6 The Daisy Chain Connection Controller to Controller

Two common INCORRECT connection methods are displayed in Fig.3.7:

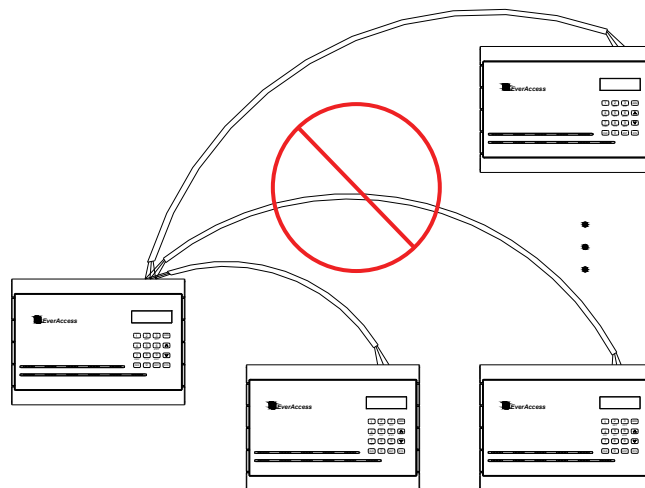
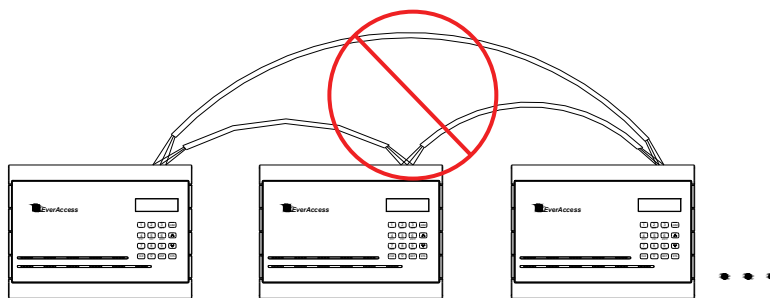

Fig. 3.7 Two INCORRECT Connections

3.5 Connection to Multiple Controllers via RS485

Up to 127 controllers can be connected to each desktop reader via RS485 bus. The correct RS485 connection method has been briefly introduced in the section “RS485 Bus Extension”. Here are the details to connect multiple controllers via RS485, shown as Fig. 3.8. The terminal 15, 16 and 17 on the main module should be connected to the upper level controller’s terminal 15, 16 and 17.

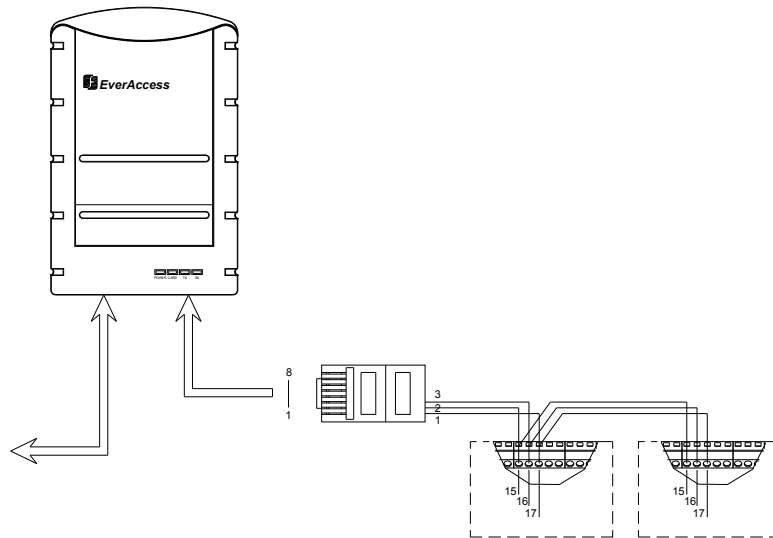

Fig. 3.8 Connection to Multiple Controllers via RS485

3.6 TCP/IP Based System

It is also possible to network the controller via TCP/IP in order to remotely manage the controller over internet or intranet. This is accomplished using the EverAccess LAN adaptor (part number EA-LAN1) to convert RS232 /RS485 signals to TCP/IP. Fig. 3.9 diagrams this type of installation.

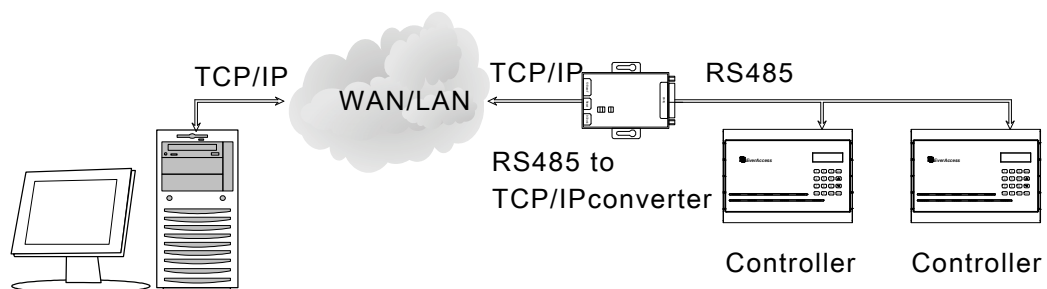

Fig. 3.9 Diagram for TCP/IP based System

The following is a step-by-step guide to setting up an EA-LAN1 network adaptor:

Step 1: Install the EA-LAN1 software on the Installation PC using the CD included with the EA-LAN1. Make sure that the installation PC is connected to the network that will be used to manage the controller.

Step 2: Connect the EA-LAN1 to the local area network using a LAN cable, and power up the EA-LAN1.

Step 3: Using the software that you installed in Step 1 on the Installation PC, locate the EA-LAN1 on the local area network and change the IP address on the EALAN1.

Step 4: Configure the EA-LAN1. Please refer to the EA-LAN1 user manual for details.

Step 5: Connect the EA-LAN1 to the controller. (Note: Perform this step only after successfully completing steps 1-4)

Step 6: Install the "COM Port Simulator" driver on the Admin PC using the CD included with the EA-LAN1, and map the COM Port to be used.

Step 7: Confirm that the controller is now available on the network. At the Admin PC, start the EverAccess Flex Software and connect to the controller using the COM Port mapped in Step 6.

Chapter 4

4 Connecting Power

4.1 Connecting the Power Supply

Connect the positive end to the terminal 18 on the main module and the GND to terminal 19 on the main module, as shown in Fig. 4.1.

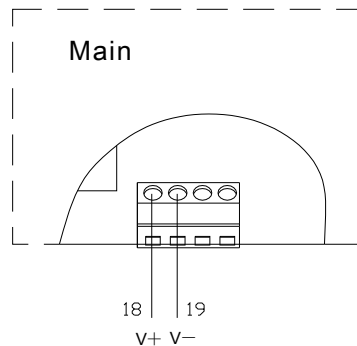

Fig. 4.1 Connection to Power Supply

The voltage supply for EverAccess Flex II controller can handle a range of DC 11V ~16V. The maximum current draw of the controller is 500 mA. If the backup battery is connected to the controller, a power supply with DC15V output is required. The power supply in the EverAccess enclosure is DC15V. In addition, the controller provides a 12V power supply for the card readers. It should be noted that if a controller powers multiple card readers, the current draw will be increased. The total current draw can be calculated as below:

$$Current_{controller} = 500 + current_{reader} \times number_{readers\ connected\ to\ controller}$$

Important Tips: The voltage supply should be located no more than 2 meters from the controller. Also, electric locks and alarm devices **MUST** be powered separately. The controller's power supply can power the controller and modules, and the card readers, but **NOT** the locking hardware or alarm.

4.2 Mount a Backup Battery (optional)

If the installer chooses, a backup battery may be mounted in the EverAccess enclosure and connected to the controller to provide backup power in the event of external power loss. Once the battery is installed, it will charge off the external power until it is needed, at which time it will automatically be used to power the system.

4.3 Connection to Backup Battery

Connect the positive end of the backup battery to terminal 20 and the negative end of the backup battery to terminal 21, as shown in Fig. 4.2:

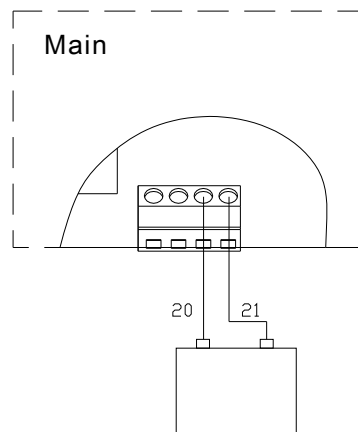

Fig. 4.2 Connection to Backup Battery

If a backup battery is connected, the controller will automatically switch to backup power in the event that the external power is lost. The backup battery will charge while external power is being supplied. In general, the larger the battery capacity is, the longer it can support the controller. Roughly speaking, a 12AH battery can provide 4 hours of energy for a controller containing 4 door modules, 1 alarm modules and 8 card readers.

4.4 Reset Controller

Before turning the power on, please double check to ensure that all the wiring and connections are correct. In order to restore factory default settings, switch the power on while holding down the RESET switch. The RESET switch is shown in Fig 4.3:

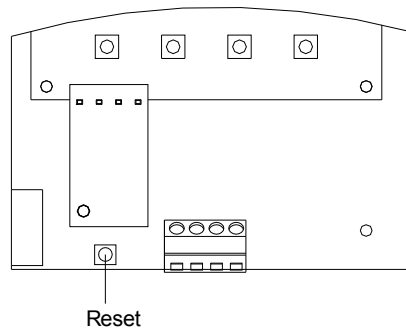

Fig. 4.3 Reset switch

4.5 Cover Placement

- The cover has two latches on the interior of the top horizontal edge. Place these latches in the corresponding holes on the top horizontal edge of the controller base-board.
- Once the latches are in place, the bottom portion of the cover will fit easily over the rest of the controller base-board.
- Using the screws (provided in the controller package) to secure the cover to the controller base-board along the exterior of the horizontal bottom edge.

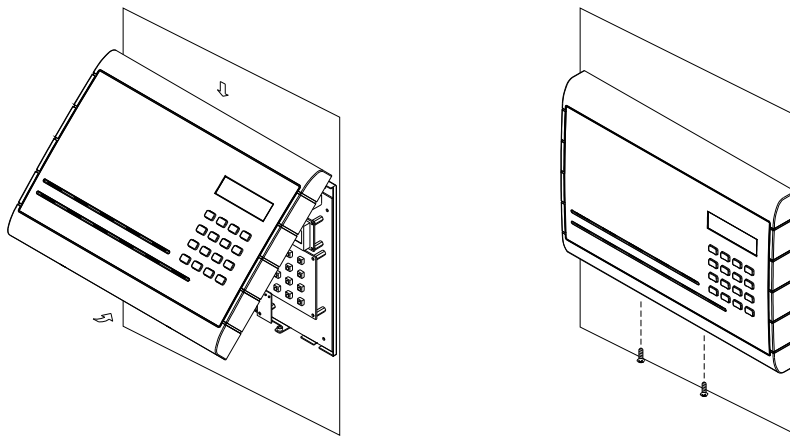

Fig. 4.4 Cover Placement

4.6 Before First Use

The operations must be performed in preparation before the first use:

- Set the date and time for the controller

- 2) Set the controller address
- 3) Configure reader properties
- 4) Configure alarm settings
- 5) Configure door setting
- 6) Configure the holidays and schedules

Chapter 5

5 Controller Functionality and Configuration

This chapter introduces system functions and their corresponding operations. Most basic operations can be performed on the controller keypad. Some advanced functions require the EverAccess Flex Series software. Please refer to the software manual for more details.

5.1 General Operation Guideline



The controller's 4x4 keypad is shown above:

- SYS** Enters the system menu
- ARM** Arms or disarms the system
- ^** and **v** Toggle between the same level menus
- ^** Moves back one space when typing in numbers
- CLR** Cancels or exits back to the higher-level menu
- ENT** Confirms the operation

5.2 Enter System Configuration

After the system installation is completed, the controller LCD will display the current date and time. This display is the default screen, and will be displayed until the user logs in to the system configuration by entering a password. After logging in to the system administration, pressing **CLR** key to return to the previous menu. In addition, after one minute of

inactivity or holding down **CLR**, the controller will automatically return to the main menu.

2009-06-29 MON
09:38

Under the main menu, pressing **SYS** on the keypad will bring up a prompt to enter system password, as shown below:

Input SYS Password

Enter the system password and press **ENT** to enter system setting menu. The password is present to 00000000 at the factory. In order to secure the controller, change the password after the first login and keep the password in a safe place. If an incorrect password is entered three times consecutively, the system will alarm automatically and lock the keypad for a period of one minute. Press any key during this time period; the system will display the following message:

Input Password err
Keypad is Locked!

Under the main menu, pressing **ARM** on the keypad will bring up a prompt to enter ARM password, as shown below:

Input ARM Passwrod

Enter the ARM password and press **ENT** to enter ARM setting menu. The password is present to 00000000 at the factory. In order to secure the controller, change the password after the first login and keep the password in a safe place. If an incorrect password is entered three times consecutively, the system will alarm automatically and lock the keypad for a period of one minute. Press any key during this time period; the system will display the following message:

Input Password err
Keypad is Locked!

5.2.1 Display the hardware Version

Under the main menu, press **0** to show the version information of the currently installed hardware. An example is shown below:



Version: 2 . 0 . 0 . 0

5.2.2 Display the Number of Installed Modules

Under the main menu, press **1** to show the number of installed door modules and alarm modules. An example is shown in the following figure. In this example, 4 door modules and 1 alarm module are installed in the controller, as shown below:

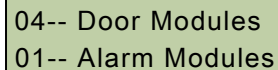

04-- Door Modules
01-- Alarm Modules

5.2.3 Display the Number of Cards and Events

Under the main menu, press **2** to show the total number of cards enrolled in the controller and recorded offline events. An example is shown in the following figure. In this example, there are total 100 cards enrolled and 36555 recorded offline events, as shown below:

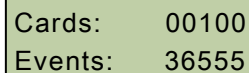

Cards: 00100
Events: 36555

5.3 Main Setting Items

The first level menus are displayed after entering the system menu. Use **▲** and **▼** to toggle between menu options and press **ENT** to enter the selected option. The first level menu items are shown below:

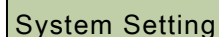

System Setting

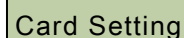

Card Setting

Door setting

Reader Setting

Alarm Setting

Address Setting

5.4 System Setting

Under the System Setting menu, user can configure: date format, date, time, auto daylight saving, SYS password, ARM password, language, time server, backlight, erase all records and restore factory setting.

5.4.1 Enter System Setting Menu

In the first level menu, select “System Setting” as shown below:

System Setting

Press **ENT** to enter System Setting menu. Use **▲** and **▼** to choose from different menu options. All menu options in the System Setting Menu are introduced below:

5.4.2 Set Date Format

Under the System Setting menu, select “Set Date Format” as shown below:

Set Date Format

User can choose between two date formats: ‘MM-DD-YYYY’ or ‘YYYY-MM-DD’. To change this option, use **▲** and **▼** keys to select “Set Date Format”, and press **ENT**, the following window will be displayed:

MM-DD-YYYY
[ENT] to toggle

YYYY-MM-DD
[ENT] to toggle

The current date format used will appear on the LCD screen. Press **[ENT]** to toggle between the two formats. Press **[CLR]** to exit without changing the setting.

5.4.3 Set Date

Under the System Setting Menu, select “Set Date” and press **[ENT]** to enter.

Set Date

The LCD will display the following menu. Use the numerical keys to enter the current date as a six-digit number: (YY: MM: DD). The year must be in the range of 2000-2099. When finish, Press **[ENT]** to confirm the new date.

Set Date(YY-MM-DD)
20__--__--__

The date and time can be set at the controller. However, if the controller is connected to a PC with EverAccess Flex Series software installed, the software will automatically modify the controller date and time to match the time on the PC. If the controller date and time are found to be incorrect, check the date and time on the management PC.

5.4.4 Set Time

Under the System Setting Menu, select “Set Time” and press **[ENT]** to enter

Set Time

The LCD will display the following menu. Use the numerical keys to enter the current time as a six-digit number (HH:MM:SS). The time must

be in the range 00:00:00--23:59:59. After entering the time, press **ENT** to confirm.

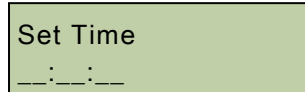

5.4.5 Auto Daylight Saving

Under the System Setting Menu, select "Auto Daylight Saving" and press **ENT** to enter the menu, as shown below:

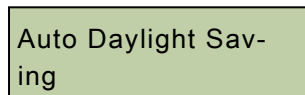

Press **ENT** to toggle the setting between Enabled/Disabled, Press **CLR** to exit without changing the current setting

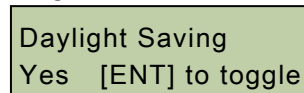
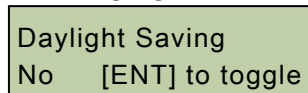

When Auto Daylight Saving (DST) is enabled, user can define the start and end dates of DST by using the EverAccess Flex series Software. If the start of DST is setting the clock forward one hour at 01:59:59am of the first Sunday in April, and the end of DST setting the clock backward one hour at 01:59:59am of the last Sunday in October, the controller will automatically adjust DST one hour forward from 1:59:59am to 3:00:00am on the first Sunday in April, and adjust it back one hour from 2:59:59am to 2:00:00am on the last Sunday in October.

5.4.6 Set System Password

A System password must be entered before the user can make management changes via the controller keypad. The factory default System password is 00000000. It is recommended that the password be changed after the initial login for maximum security. Be sure to keep the new password; if lost, the system can only be accessed after purging all stored data by resetting from the keypad.

Under the System Setting Menu, press **ENT** to enter the menu to set system PIN.

Set SYS Password

The system will prompt user to enter a new 8-digit password. When finish, press **ENT** to confirm and the user will be asked to reenter the password. The two entries must be the same. Pressing **CLR** at any time will exit the menu without changing the system PIN.

Input SYS Password

Repeat:

Setting updated
successfully

If the two passwords are not the same, the system will display an error message and exit to the previous menu.

Passwords mismatch
Please retry

5.4.7 Set ARM Password

ARM password must be entered before the controller can be armed or disarmed via the controller keypad. The factory default ARM password is 00000000. It is recommended that the password be changed after the initial login for maximum security. Be sure to keep the new password.

Under the System Setting Menu, select “Set ARM Password” and press **ENT** to enter the menu to Set ARM Password.

Set ARM Password

The system will prompt user to enter a new 8-digit password. When finish, press **ENT** to confirm and the user will be asked to reenter the password. The two entries must be the same. Pressing **CLR** at any time will exit the menu without changing the ARM PIN.

Input ARM Password

Repeat:

Setting updated
successfully

If the two passwords are not the same, the system will display an error message and exit to the previous menu.

Passwords mismatch
Please retry

5.4.8 Set Language

Under the System Setting Menu, select “Set Language” and press **ENT** to enter

Set Language

Press **ENT** to toggle among Chinese, English and Russia, press **CLR** to exit without changing the current setting.

简体中文
按 [ENT] 切换

English
[ENT] to toggle

А н г л и й с к и й
[ENT]- ИЗМЕНИТЬ

5.4.9 Time Server Setting

Under the System Setting Menu, select “Time Server Setting” and press **ENT** to enter.

Time Server
Setting

Press **ENT** to toggle between time sever enabled/disabled, press **CLR** to exit without changing the current setting.

Time server EN
[ENT] to toggle

Time server DisEN
[ENT] to toggle

5.4.10 Backlight Setting

Under the System Setting Menu, select “Backlight Setting” and press **[ENT]** to enter.

Backlight
Setting

Press **[ENT]** to toggle between backlight enabled/disabled, press **[CLR]** to exit without changing the current setting. If the backlight is enabled, the LCD screen on the controller will be turned on.

Backlight OFF
[ENT] to toggle

Backlight ON
[ENT] to toggle

5.4.11 Erase All Events

The controller will record all events that occur, beginning immediately upon powering on. The recorded events can be erased by following the instructions below. If the controller is never connected to a PC, then old records will be automatically overwritten when storage space is full (170,000 events max.).

Under the System Setting Menu, select “Erase All Events” and press **[ENT]** to enter.

Erase All Events

LCD will prompt the user to confirm the action:

Are you sure?
[ENT] to continue

Press **[ENT]** to erase all recorded events.

5.4.12 Reset All Data and Setting

This function is used to reset all settings to factory set default values.

Under the System Setting Menu, select “Rest ”and press **[ENT]** to enter

Restore Factory
Setting

LCD will prompt the user to confirm the action:

Are you sure?
[ENT] to continue

Press **[ENT]** to reset all data and setting.

5.5 Card Setting

Card setting can be configured using either the controller or the EverAccess Flex Series software. Using the Flex Series software is the easiest way to enroll cards. However, enrolling at the controller can be useful if the controller is offline. The process is described below.

5.5.1 Enter Card Setting Menu

Under the System Menu, press **[V]** once to bring up the following window:

Card setting

Press **[ENT]** to enter the Card Setting menu. Use **[^]** and **[v]** to choose from different menu options. All menu options under the Card Setting menu are introduced below:

5.5.2 Add Cards

When a new card is added, the controller will automatically assign an index number in the order of enrollment. The index number here is not related to the card number in the EverAccess Flex Series software. Users do not need to take care of this number.

Under the Card Setting menu, press **[ENT]** at the window below to add a card.

Add Cards

Press **ENT** to enter the interface to enter card number, as shown below:

Input Card Serial
card#:_____

By either entering a card number or swiping the card through the system reader, the system will automatically acquire the index number of the new card and add it to the controller. Card number must be bigger than 0.

Input Card Serial
card#:000000000001

Press **ENT** to confirm and the system will add the card to the controller database.

5.5.3 Delete Cards

The user can directly delete an individual card with a specific index or serial number from the controller, or delete all cards at once. Under the Card Setting menu, press **V** once to bring up the following window:

Delete Cards

Press **ENT** to enter the sub-menu of the two options to delete cards.

5.5.3.1 Delete a Card by Serial Number

The controller can delete a card according to its serial number, which is printed on the face of each card. At the following window:

Delete a Card

Press **ENT** and the system will prompt the user to enter a serial number, as shown below:

Input Card Serial
card#: _____

After entering the serial number, press **[ENT]** and the system will prompt to confirm the deletion

Are you sure to de
lete 000009251887

Press **[ENT]** to delete.

5.5.3.2 Delete All Cards

All cards can be deleted at once. At the following window:

Delete All Cards

Press **[ENT]** and system will prompt the user to confirm deletion:

Are you sure?
[ENT] to continue

Press **[ENT]** to delete all cards.

Caution: this operation will permanently delete ALL cards from the controller database.

5.5.4 Set Card Properties

Under the Card Setting menu, press **[V]** twice to bring up the following window:

Set Card
Properties

Press **[ENT]** and system will prompt the user to enter serial number, as shown below:

Input Card Serial
card#: _ _ _ _ _

After entering the serial number, press **[ENT]** to enter the submenu for setting card properties. Each card has 6 properties that can be edited. Use **[^]** and **[v]** to choose desired properties.

5.5.4.1 Status Setting

A card can be set as enabled or disabled at the following submenu:

Status Setting

Press **[ENT]** and system will show the status of current card as the figure below. Press **[ENT]** to toggle between the two statuses. Press **[CLR]** to exit without affecting any change.

Card enabled
[ENT] to toggle

Card disabled
[ENT] to toggle

5.5.4.2 First Card setting

A card can be set as first card at the following submenu:

1st-person-in

Press **[ENT]** and system will show whether the first card function is enabled or disabled for the current card. Press **[ENT]** to toggle between the two statuses. Press **[CLR]** to exit without affecting any change.

1st-person enabled
[ENT] to toggle

1st-person disable
[ENT] to toggle

5.5.4.3 Anti Passback (APB) Setting

At the following submenu, press **[ENT]** to enter Anti-Passback setting:

APB Setting

Press **[ENT]** and system will show whether Anti-Passback setting is enabled or disabled for the current card. Press **[ENT]** to toggle between the two statuses. Press **[CLR]** to exit without affecting any change.



5.5.4.4 Set Card PIN Setting

Each card in the EverAccess access control system is associated with an 8-digit PIN. The PIN status can be set as enabled or disabled and if enabled, and the door open mode is set to be “card plus PIN” or “PIN only”, user is required to enter the PIN every time he enters/exit the door. The reader must be a keypad reader to enable this function.

At the following submenu, press **[ENT]** to enter PIN setting:

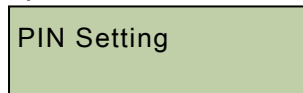

The PIN status of the current card i.e. enabled or disabled will be displayed as shown below. Press **[ENT]** to toggle between the two statuses. Press **[CLR]** to exit without affecting any change .



5.5.4.5 Modify Card number

Each card in the EverAccess access control system has a unique serial number, which can be modified in the following menu, press **[ENT]** to enter:

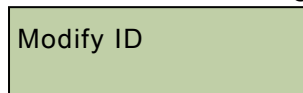

Following the instruction to enter the new serial number. User can swipe the card through the system reader and the serial number will be automatically displayed in the screen, or user can enter the new serial number manually. When finish, press **[ENT]** to confirm. If the number already exists in the database, the system will display an error message:

Card already exist
ed

If the modification succeeds, the system will display:

Card properties
updated successfully

5.5.4.6 Modify Card PIN

Each card in the EverAccess access control system has a 8-digit PIN, which can be modified in the following menu, press **ENT** to enter :

Modify PIN

Following the instruction to enter the new PIN, press **ENT** to confirm. The system will prompt to enter the PIN a second time,

Input New PIN:
_ _ _ _ _

Repeat New PIN:
_ _ _ _ _

If the two entries are different, they system will display

Passwords mismatch
Please retry

If the modification succeeds, the system will display:

Card properties
updated successfully

5.5.5 Show Card Number

This function can be used to show the serial number of a card when it is swiped on the system reader. Under Card Setting menu, press **▼** three times to bring up the following window:

Show Card Number

Press **[ENT]** and swipe the card on the system reader. The serial number of the card will be displayed as shown below. Press **[CLR]** to exit.

Registered:_____
Card#:_____

5.6 Door Setting

Every door module controls two door relays. Flex II controller can control up to 8 doors in total, defined as door 1 to 8 from left to right. According to card reader setting above, users can allocate multiple readers to one single door. User can directly set door open time, door held open time and door open mode.

5.6.1 Enter Door Setting Menu

Under System menu, select “Door Setting” as shown below:

Door Setting

Press **[ENT]** to enter Door Setting menu. Use **[^]** and **[v]** to choose from different menu options. All menu options under Door Setting are introduced below:

5.6.2 Time Zone Setting

Schedule Switch
Setting

Time zone setting means whether the current door open mode is controlled by the controller or by the rules defined in the Flex Series Software in PC. The door open mode is controlled by Software when Time Zone is enabled, and controlled by the controller when Time Zone is disabled.

Schedule Disabled
[ENT] to toggle

Follow controller setting

Schedule Enabled
[ENT] to toggle

Follow Software setting

5.6.3 Set Door Open Mode

Door Access Mode

Each door can be controlled by one of 13 door open modes, including normally open, card only, fingerprint only etc. To start, enter the door number

Input Door
Index: _

After entering the door number, press **[ENT]** to confirm. Select the desired mode from the list below and press **[ENT]** to confirm. The selected mode will be labeled as “*current”. The system default mode is “card only”:

Card Only
* Yes

Fingerprint Only

Card + PIN

Card + Fingerprint

Fingerprint + PIN

Card + PIN +
Fingerprint

Card or PIN or
Fingerprint

Fingerprint or
Card

(Card + PIN) or
Fingerprint

(Fingerprint or
PIN) + Card

(Card or PIN) +
Fingerprint

(Fingerprint or
Card) + PIN

Always Unlocked

Forbid Access

5.6.4 Open Time Setting

This function sets the door open time when the card is swiped or open door button is pushed. The default time is 3 seconds. The maximal door open time supported by the controller is 999 minutes and 59 seconds. The door remains open as long as the open door button is pushed down. The door open time does not count until the button is released. At the following submenu:

Open Time Setting

Press **ENT** to enter Open Time setting. In the menu shown below, press numeric key 1~8 to enter the desired door number in the Door field. (The max number depends on the actual door modules installed in the controller) Enter the desired door open time in the Open Time field: enter

minutes as a 3-digit number 0~999, and enter seconds as a 2-digit number 0~59. Press **ENT** to confirm. Press **CLR** to exit without affecting any change.

```
Door--1  Open Time
___Min __ Sec
```

5.6.5 Set Door Held Open Time

Door sensor monitors the open/close status of a door. If normally open is not set by the system (door is normally considered closed), then door should close after opening for a while. It is considered abnormal if controller does not receive the door close signal from door sensor a reasonable amount of time after the door is opened. This time period is call door held open time or door over time. According to this setting, EverAccess controller will determine whether to generate an alarm or not after the door sensor timeouts. The default value of door hold open time is 5 seconds. The maximal door hold open time supported by the controller is 999 minutes and 59 seconds. At the following submenu:

```
Over Time Setting
```

Press **ENT** to enter Door Held Open Time setting. In the menu shown below, press numeric key 1~8 to enter the desired door number in the Door field (The max number depends on the actual door modules installed in the controller). Enter the desired door held open time in the Open Time field: enter minutes as a 3-digit number 0~999, and enter seconds as a 2-digit number 0~59. Press **ENT** to confirm. Press **CLR** to exit without affecting any change.

```
Door—1  Over Time
___Min __ Sec
```

5.7 Reader Setting

Card reader properties can be directly set on the controller, including system reader, keypad reader and the allocation of readers to doors etc.

5.7.1 Enter Reader Setting Menu

Under System menu, select “Reader Setting” as shown below:

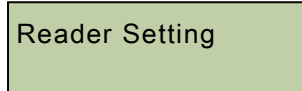

Press **ENT** to enter Reader Setting menu. Use **^** and **v** to choose from different menu options. All menu options under Reader Setting are introduced below:

5.7.2 System Reader Setting

System reader can be used to acquire the card's serial number when controller configures the card. User can set any reader that connects to the controller as the system reader. At the following submenu

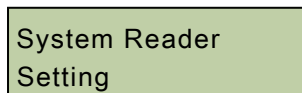

Press **ENT** to enter System Reader setting. System will show current status of all readers as shown below. Y means the reader is the system reader, N means it's not. By default, there is no system reader and user needs to set the system reader.

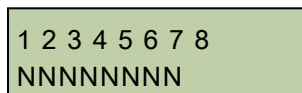

Press any of the 1-8 numeric keys to change the system reader setting of the corresponding readers. Press **CLR** to exit.

5.7.3 Keypad Setting

Keypad Setting defines whether the reader is a keypad reader. For a keypad reader, if the password property of the card is set as enabled, and the access right of the door is set as card plus password, then user is asked to enter password when the card is swiped on the keypad reader. At the following submenu:

Keypad Setting

Press **ENT** to enter keypad setting. System will show keypad setting status of all installed readers. “Y” means the reader is a keypad reader, and “N” means the reader is a non-keypad reader. By default, every reader is set as a non-keypad reader. Flex controller will display the door number according to the number of installed door modules. In the following example, 4 door modules (8 readers) have been installed on the controller.

1 2 3 4 5 6 7 8
NNNNNNNN

Press numeric keys to toggle the keypad setting of corresponding reader. Press **ENT** to confirm. Press **CLR** to exit without affecting any change.

5.7.4 Reader to Door Allocation

EverAccess Flex II controller can be flexibly configured. Readers can be allocated to different doors, and can be set as ENTER only or EXIT only. By default, each reader is allocated as ENTER only to the door with the reader’s number. At the following submenu:

Reader to Door
Allocation

Press **ENT** to enter Reader to Door Allocation setting. System will show the allocation of the first reader to door as follows :

Reader-1
Door-1-IN

Press any of the 1-8 numeric keys to allocate the current reader to corresponding doors (This depends on the actual door modules installed on the controller). Press the same numeric key to toggle between ENTER only (IN) and EXIT only (OUT). Press **▲** or **▼** to select other reader. Press **CLR** to exit.

5.7.5 Reader Input Time Setting

When open door mode need card holder input his password, there is period to him, he must be input his password within the time, this time called "Reader input time".

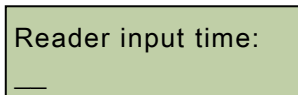

Reader input time:
—

At here, this time max is 60 seconds, default is 10 seconds. All readers use same input time.

5.7.6 Reader Backlight Setting

Press **ENT** to enter Reader Backlight Setting. System will show the current status of backlight setting of all readers, as shown below. Y means enabled and N means disabled. By default, all reader backlight is disabled.

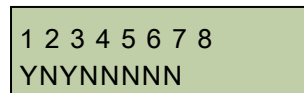

1 2 3 4 5 6 7 8
YNYNNNNN

Press any of the 1-8 numeric keys to change the backlight setting of the corresponding doors. Press **CLR** to exit.

5.7.7 Set Reader LED or LCD Format

There are 2 display mode reader in our company, LED mode and LCD mode, LED reader display use 4bits digitrons, this setting is adapted to LED reader.

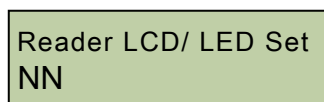

Reader LCD/ LED Set
NN

N indicate LCD display, Y indicate LED display.

5.7.8 Card Format Setting

Press **ENT** to enter card format Setting. System will show the current status of card format setting of all readers, as shown below. Y means the

card from this reader will be revert(for example: card serial is :0x12 34 56 78, if the option is set to Y, the card serial from this reader will be: 0x78 56 34 12) and N means don't revert. By default, all reader for this is disabled.

1	2	3	4	5	6	7	8
Y	N	N	N	N	N	N	N

Press any of the 1-8 numeric keys to change the backlight setting of the corresponding doors. Press  to exit.

5.8 Alarm Setting

EverAccess Flex II controller is equipped with powerful alarm functions. With alarm modules and door modules fully installed, the controller can accommodate up to 10 alarm inputs and 18 alarm outputs. At the meantime, EverAccess Flex II controller also provide very flexible configuration. Any event can be arbitrarily allocated to single or multiple alarm outputs. Alarm components, configuration basics, and menu settings are introduced below.

5.8.1 Components for Alarm

EverAccess Flex II controller consists of two basic components: the main module and the door module. User can install up to 4 door modules and 1 alarm module.

These three types of module are all equipped with alarm function. The main module has 2 alarm inputs and 2 alarm outputs. Each door module has 2 alarm outputs, which usually react to alarm events on the corresponding door. However, it can be set to react to other alarm events as well. Alarm outputs on the door module can connect up to 5A external alarm devices.

Alarm module has 8 alarm inputs and 8 alarm outputs. 8 alarm inputs can connect to external alarm input devices, such as PIR motion sensor, glass sensor and etc. 8 alarm outputs can connect up to 2A external alarm devices.

The above mentioned are physical devices providing alarm function. User can freely define the allocation of any input to any output. The following section outlines basic concepts for events, alarm and configuration.

5.8.2 Alarm Configuration Basics

EverAccess Flex II controller keeps tracking all events in the access control system, either legal or illegal, either normal or abnormal, for example, the granted access, the denied access and so on.

Some events are critical which must trigger the alarm output, like the fire alarm input, the zone alarm input and etc. But some events are not so important to trigger the alarm output, like the denied access due to the invalid time. These settings all depend on the users' requirements. EFC202 controller collects all events that might trigger the alarm output and provides the full capacity to enable or disable the alarm output on these events.

Sometimes user wishes to allocate a particular event to a particular alarm output, or allocate alarm inputs in certain area to multiple alarm outputs. EFC202 controller delivers all the function and flexibility user need. User can define whether certain event will trigger an alarm, and can further specify to which alarm output that event is allocated.

An alarm can be triggered by events such as fire alarm, zone alarm 1~9, unknown card, expired card, invalid card, invalid door, invalid time, card anti-pass back fail, card PIN fail, SYS PIN fail, ARM PIN fail, door forced open, door held open, reader lost and remote alarm. All these events can be allocated to any alarm relay output on main module, door module and alarm module. The detailed configuration method is introduced in the following section.

5.8.3 Enter Alarm Setting Menu

Under System menu, select "Alarm Setting" as shown below:

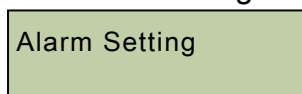

Press **ENT** to enter Alarm Setting menu. Use **▲** and **▼** to choose from different menu options. All menu options under Alarm Setting are introduced below:

5.8.4 Alarm Setting Menu Structure

There are three submenus under Alarm Setting, as shown below:

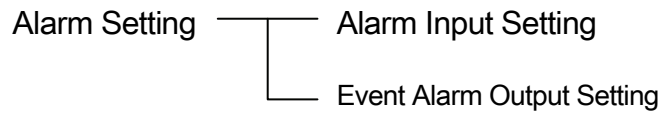

Alarm Input Setting menu is used to configure alarm inputs on main module and door module. The setting includes alarm input mode, output mode, whether fire alarm or other type, alarm output action, door behavior in fire alarm, arm delay time and alarm output time etc.

Event Alarm Output Setting menu consists of event alarm output time setting and event alarm action setting.

5.8.5 Alarm Input Setting

Under Alarm Setting menu, select “Alarm Input Setting” as shown below:

Alarm Input
Setting

Press **ENT** to enter Alarm Input Setting. The system will prompt user to choose the alarm input channel that needs to be configured, as shown below. There are total 10 alarm input channels.

Alarm input----1
setting

Enter the channel number “1” and then Press **ENT** to enter the Alarm Input Setting menu for channel 1. The first submenu is Alarm Input mode, use **▲** and **▼** to choose different options for different event.

Alarm Input Mode
Setting

There are three Alarm Input Mode: Normally Open, Normally Close and Invalid. Press **ENT** to choose from the three options.

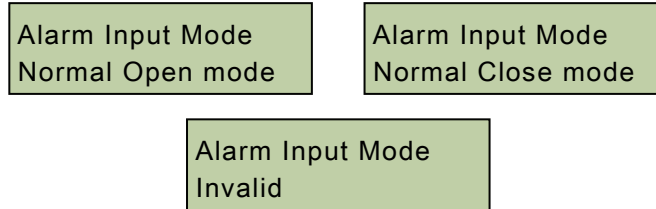

Normally Open means the circuit disconnects in the normal condition (i.e. without input) and connects with activated inputs. Normally Close is the opposite: the circuit connects in the normal condition (i.e. without input) and disconnects with activated inputs. Invalid means the current alarm zone is disabled.

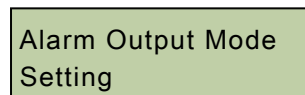

There are two types of output mode: Lock and Sync. Press **ENT** to toggle between the two options.



Sync mode means the alarm output is directly synchronized with the alarm input. Specifically, there will be an alarm output once an input signal is triggered and the alarm outputs stops when the input signal stops. The sync mode is not affected by alarm delay time; Lock mode means, there will be an alarm output only after the arm delay time when an input signal is triggered. Once triggered, the alarm output remains until alarm time is reached even if the input signal stops during this time period.

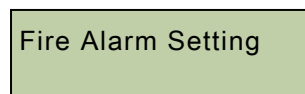

Fire Alarm Setting is used to indicate whether the current alarm is a fire alarm or not. a fire alarm has the highest priority and cannot be disarmed. In addition, there is no arm delay time for fire alarm. All 10 alarm input channels can be set as fire alarm.



EverAccess Flex II controller can connect up to 18 alarm outputs, including 2 from the main module, 8 from door module and 8 from extendable module. Alarm Output Action Setting consists of 3 sub-menus accordingly, as shown below:

Alarm Act Setting
on Main Module

Alarm Act Setting
on Door Module

Alarm Act Setting
on Extern Module

The first sub-menu is “Alarm Setting on main module”, press **ENT** to enter the sub-menu. The LCD will show the current output status of alarms on the main module. Y means there is an alarm output and N means no alarm output.

Alarm act on main
YN

As there are 2 alarm outputs from the main module, there are 2 items on this menu corresponding to the 2 outputs. Press number key “1” or “2” to toggle the selection between Y and N of the corresponding channel.

The second sub-menu is “Alarm Setting on Door Module”: The controller can connect up to 4 door modules and there are 2 alarm outputs from each door module. When all 4 door modules are installed, there will be total 8 alarm outputs on this sub-menu. Y means there is an alarm output and N means no alarm output. Press number key “1”~ “8” to toggle the selection between Y and N of the corresponding channel.

Alarm act on door
NNNNNNNN

The last sub-menu is “Alarm Setting on extendable module”: The controller can also connect to 1 alarm module besides 4 door modules. There are 8 alarm inputs and 8 alarm outputs on the alarm module. If an alarm module is installed, user can configure the alarm setting here. The 8 alarm inputs correspond to alarm input 2~9. Their output status will be shown in the LCD display as below:

```
Alarm act on alarm
NNNNNNNN
```

All 10 alarm inputs can be set as fire alarm. Fire alarm has the highest priority. User can configure the door behavior in the event of fire alarm. Y means door open and N means door close.

```
Door act on fire
YYYYYYYY
```

When an alarm input is set as arm zone alarm input (not fire alarm), one property is Arm Delay Time. When an arm operation is executed, all active arm zones will enter ARM enabled status only after a certain time delay, which is called ARM delay time. EverAccess Flex II controller supports configuring ARM delay time for each individual alarm input.

```
ArmDelay Time
Setting
```

Press **ENT** to enter ARM delay Time setting:

```
arm delay time
__Min __Sec
```

The default ARM delay Time is 30 seconds. When an alarm is triggered, the alarm output will remain active for a certain period of time called alarm output time. The alarm output will be cleared when alarm output time has elapsed (Except for fire alarm). Fire alarm can only be reset manually. The default alarm output time is 60 seconds.

```
alarm time
__Min __Sec
```

5.8.6 Event Alarm Output Setting

In Alarm Setting, besides physical alarm inputs, user can configure illegitimate events such as unknown card, invalid card, expired card, invalid time, and invalid door and so on. There are two options in alarm

event setting: alarm event action and alarm event time. Alarm event action set the output terminal of the event.

Alarm Event
ActionSetting

Event Alarm Output Setting consists of two items: event alarm output time setting and event alarm action setting:

Event Alarm Time
Setting

EventAlarm action
Setting

Event alarm action is to set the alarm output terminal of the event. The 18 alarm outputs from the main module, door module and extendable module can be set in the corresponding sub-menus, as shown below:

Event Alarm Action
On Main Module

Event Alarm Action
On Door Module

Event Alarm Action
On Alarm Module

Select “Event Alarm Setting on main module” and press **ENT** to enter the alarm output setting for illegitimate event on the main module. The LCD will show system PIN fail first, the default setting is no output from the main module. Keep pressing **▼**, and the system will list all of the illegitimate events. Y means there is an alarm output and N means no alarm output. Press number key **1** and **2** to toggle between Y and N.

- System Password Fail: User is required to enter system password to enter the system setting menu. EFC202 controller supports an 8-digit system password. The default system password is “00000000”. Please change the system password after installation and keep it in a safe place. If a wrong system password is entered

three times consecutively, the system will generate a “system password fail” alarm and lock the keypad for a period of 1 minute. The default setting is that there will be no alarm output from the main module terminal for system password fail.

SYS Password Fail
NN

- ARM Password Fail: User is required to enter ARM password when press  to arm/disarm the system. The default ARM password is “00000000”. Please change the ARM password after installation and keep it in a safe place. If a wrong ARM password is entered three times consecutively, the system will generate an “ARM password fail” alarm and lock the keypad for a period of 1 minute. The default setting is that there will be no alarm output from the main module terminal for ARM password fail.

ARM Password Fail
NN

- Remote Alarm: System administrator can directly generate alarm signal using control software when he observes abnormal condition through surveillance system such as CCTV. This is defined as a Remote Alarm event. The default setting is that there will be no alarm output from the main module terminal for remote alarm.

Remote Alarm
NN

- Unknown card: unknown card refers to a card that is never registrated in the system. An Unknown Card event will be generated when an unknown card is swiped on the reader. The default setting is that there will be no alarm output from the main module terminal for remote alarm.

Unknown Card
NN

- Expired Card: any card in the system is usually assigned a valid date. After the valid date is passed, the controller will automatically set the card as an expired card. An expired card cannot gain access to the system. At the same time, an Expired Card event will be generated

when an expired card is swiped on the reader. The default setting is that there will be no alarm output from the main module terminal for expired card.

Expired Card
NN

- Invalid Card: User can directly set a card as invalid card to disable the card. An invalid card cannot gain access to the system. At the same time, an Invalid Card event will be generated an invalid card is swiped on the reader. The default setting is that there will be no alarm output from the main module terminal for invalid card.

Invalid Card
NN

- Invalid Door: Each card belongs to an access group. For each group, the system can assign access rights for certain doors and certain time zones. In other words, cards in an access group have rights to pass only defined doors at defined time zones. An Invalid Door event will be generated when a card is swiped at any door it does not have right to pass. The default setting is that there will be no alarm output from the main module terminal for invalid door.

Invalid Door
NN

- Invalid Time Zone: The system can define up to 10 date types and each day of the year is assigned to one of the 10 date types. Each date type can be divided to 10 time zones, with a minimum time period of 1 minutes in each time zone. Each card belongs to an access group. For each group, the system can assign access rights for certain doors and certain time zones. In other words, cards in an access group have rights to pass only defined doors at defined time zones. An Invalid Time Zone event will be generated when a card is swiped at any time it does not have right to pass. The default setting is that there will be no alarm output from the main module terminal for invalid time zone.

Invalid Time
NN

- Card Anti-Passback Fail: When the controller is fully installed with 4 door module, it can connect to 8 card readers. Each reader has a source zone and a target zone, so there will be total 16 zones in the system. If both the system anti-passback function and the card anti-passback property are enabled, a card must be used in the current reader's source zone; otherwise, it will lead to anti-passback fail. After passing the door, the card will be in the reader's target zone. A card anti-passback fail will generate an event alarm. The default setting is that there will be no alarm output from the main module terminal for card anti-passback fail.

APB Failed
NN

- Card PIN Fail: every card in the system has a card PIN. When a card is swiped at the reader where "Card Plus PIN" is set as the door open mode, the user will be asked to enter the card PIN. If wrong PIN is entered, the user will be asked to reenter the PIN. If wrong PIN is entered three times consecutively, a Card PIN Fail event will be generated. The default setting is that there will be no alarm output from the main module terminal for card PIN fail.

Card PIN Failed
NN

- Door Forced Open: each door module on the controller can control 2 doors, each of which equipped with a door sensor. A door forced open event will be generated when controller detects that a door is opened from the door sensor without any legitimate door open command (either swiping card or door open button operation). The default setting is that there will be no alarm output from the main module terminal for door forced open.

Door Forced Open
NN

- Door Held Open: the system keeps tracking of the door status after a door open action takes place. A Door Held Open event will be generated when a door is still open after the "door held open time" in

door setting has elapsed. The default setting is that there will be no alarm output from the main module terminal for door held open.

Door Held Open
NN

- Reader Lost: the system keeps tracking of the reader status (online vs. offline) in real time. A Reader Lost event will be generated when controller detects no signal from card reader. The default setting is that there will be no alarm output from the main module terminal for reader lost.

Reader Lost
NN

- Duress Door Open: Duress Door Open means when entering card PIN, the first 6 digits of the card PIN plus a 2-digit duress code is used. If the first 6 digits of the card PIN and the 2-digit duress code are correct, the system will open the door, and at the same time, generate a “duress door open” alarm. The default setting is that there will be no alarm output from the main module terminal for duress door open.

Panic Open
NN

Event Alarm setting on door module and extendable module is similar to those on the main module:

SYS Password Fail
NNNNNNNN

ARM Password Fail
NNNNNNNN

Remote Alarm
NNNNNNNN

Unknown Card
NNNNNNNN

Expired Card
NNNNNNNN

Invalid Card
NNNNNNNN

Invalid Door
NNNNNNNN

Invalid Time
NNNNNNNN

APB Failed
NNNNNNNN

Card PIN Failed
NNNNNNNN

Door Forced Open
NNNNNNNN

Door Held Open
NNNNNNNN

Reader Lost
NNNNNNNN

Panic Open
NNNNNNNN

Event Alarm output time setting: the system will generate an alarm output in the corresponding terminal when an illegitimate event has been detected. User can set the time period that an output remains active, called alarm output time. The output terminal will reset automatically when the alarm output time has elapsed. The system default value for alarm output time is 1 minute.

SYS Password Fail
001 Min 00 Sec

ARM Password Fail
001 Min 00 Sec

Remote Alarm
001 Min 00 Sec

Unknown Card
001 Min 00 Sec

Expired Card
001 Min 00 Sec

Invalid Card
001 Min 00 Sec

Invalid Door
001 Min 00 Sec

Invalid Time
001 Min 00 Sec

APB Failed
001 Min 00 Sec

Card PIN Failed
001 Min 00 Sec

Door Forced Open
001 Min 00 Sec

Door Held Open
001 Min 00 Sec

Reader Lost
001 Min 00 Sec

Panic Open
001 Min 00 Sec

5.9 Address Setting

Each device connected to the same RS485 bus must have a unique address for the purpose of communications and control. When multiple controllers connect to PC via an RS485 bus, each controller must be assigned a distinct address. Procedures to set controller address are as follows:

Under System menu, press  six times to bring up the following window:



Address Setting

Press  to enter address setting menu:



Address:
0000

Enter the desired address, which must be in the range 0000~9999. Press  to confirm and press  to exit without saving.

5.10 Arm/Disarm

After an alarm module is installed, the controller defines up to 10 arm zones. EverAccess Flex II Controller can treat alarm inputs in 10 arm zones in a very flexible manner. These 10 arm zones can be armed or disarmed on the controller as described below.

5.10.1 Arm the System

User must have the ARM PIN in order to utilize this function. Please refer to the section “Set ARM Password” in this chapter for instructions on how to Set ARM Password. After system installation, the date and time information will be displayed on the LCD, as shown below:

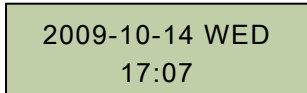

2009-10-14 WED
17:07

Press  and the system will prompt user to enter password:



Input ARM Passwrod

After entering the password, press **[ENT]** to confirm. The default password is 00000000. The LCD will display the current arm status after verification of the password.

System disarmed
[ENT] to toggle

Press **[ENT]** to arm all valid arm zones:

System armed
[ENT] to toggle

Press **[CLR]** to exit. The system enters arm state after arm delay time.

5.10.2 Disarm the System

User must have the ARM PIN in order to utilize this function. The process is similar as to Arm the system. Press **[ARM]** on the keypad and the system will prompt user to enter ARM PIN. After entering ARM PIN, press **[ENT]** to confirm and the system enters ARM/disarm interface:

System armed
[ENT] to toggle

Press **[ENT]** to disarm all the arm zones, as shown below:

System disarmed
[ENT] to toggle

Press **[CLR]** to exit.

5.10.3 Reset Alarm

When system is generating an active, ongoing alarm output, follow the procedure below to clear the alarm.

At the window showing system time, press **[ARM]** on the keypad. Enter the ARM password and press **[ENT]** to confirm. After password is verified the following menu window appears:

Reset Alarm?
[ENT] to reset

Press  to reset alarm.

5.10.4 Arm/Disarm the System using a Reader

The whole system can also be armed and disarmed using a keypad reader. (The reader must have an integrated keypad, and the keypad and system reader settings must be enabled on the controller in order to utilize this feature. Please refer to subsection “Reader Setting” for instructions on enabling these features.) The process is illustrated below using EverAccess keypad reader ERK-871 as an example.

The user must first enter a command to get into the arm operation mode. (The command is introduced in step 1 below.) In the arm operation mode, the yellow LED on the ERK-871 will show the four different system modes outlined below:

Yellow LED	System ARM Status
OFF	Indicate that the system is disarmed
ON	Indicate that the system is armed
Flash Slowly	Indicate that the system is in arm delay period
Flash Quickly	Indicate that the system is armed and some alarm input has triggered the alarm output

“ON” and “OFF” indicates the operation status when entering the ARM/DISARM menu.

The steps to arm or disarm the system at a keypad reader are as follows:

- 1) Press “*” followed by the 8-digit ARM PIN. Press “#” to enter ARM/DisARM interface;
- 2) The system will arm/disarm all enabled arm zones;
- 3) If the system is in disarmed mode (the yellow LED is OFF), press “#” to arm the system. The system will enter the arm delay period (the yellow LED will slowly flash); If the system is in armed mode, press “#” to disarm the system.

5.10.5 Arm/Disarm the System using LCD keypad Reader

User can also Arm/Disarm the system using EverAccess ERL871 LCD keypad reader, which offers a simple and straightforward interface

The steps to arm/disarm the system:

- 1) Press "*" followed by the 8-digit ARM PIN. Press "#" to enter Arm/Disarm interface;

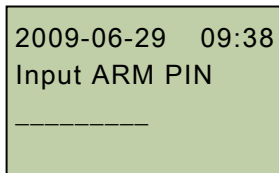

2009-06-29 09:38
Input ARM PIN

- 2) Press "#" to arm/disarm the system and press "*" to exit without affecting the current setting;

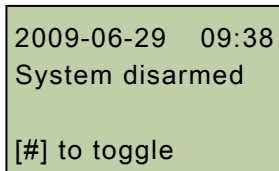

2009-06-29 09:38
System disarmed
[#] to toggle

- 3) If the system is in disarmed mode, press "#" to arm the system. The system will enter the arm delay period; If the system is in armed mode, press "#" to disarm the system.

5.10.6 Open door with PIN using keypad Reader

If the door open mode is set to "Card or PIN", directly entering card PIN on keypad reader and press "#" will open the door, after the system verifies that the PIN is correct.

The steps to open door with PIN on ERL871 LCD keypad reader is as follows:

- 1) Directly entering card PIN on keypad reader to enter "Enter card PIN" interface, as shown below:

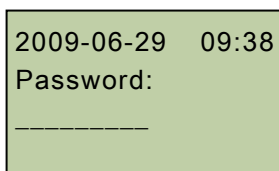

2009-06-29 09:38
Password:

- 2) After entering the PIN, press “#” to confirm. If the PIN is correct, the door will open with message “Verification Successful” showing on the LCD; If a wrong PIN is entered 3 times consecutively, an error message “ERR” will be shown and the system will exit to the main menu.

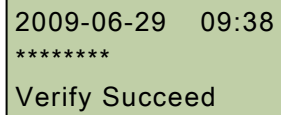
A rectangular LCD display with a light green background and a black border. The text is centered and reads: 2009-06-29 09:38, followed by a line of seven asterisks, and then "Verify Succeed".

2009-06-29 09:38

Verify Succeed

6 Software Setup

This is a brief instruction on EverAccess Flex Series Software. For a more detailed instruction guide, please refer to the EverAccess Flex Series Software Manual.

The next step after hardware installation is to configure the whole access control system. EverAccess Flex II controller has the ability to allow users configure the basic setting through the keypad on the controller. But for the detailed, complicated settings, we recommend to use the management software. To configure the system in software, several major steps that you need to follow are shown as below:

- 1) Install the software in the control computer
- 2) Setup the user accounts who will use the software
- 3) Configure the controller and all other hardware settings
- 4) Configure the holidays, access group and the door control schedule
- 5) Enroll cards and set the cardholders' properties

6.1 Install the software in the Control Computer

Just like installing any other software in the computer, inserts the software installation CD into the CDRom, and run the setup program. Choose a special installation folder if needed, otherwise just follow the setup wizard and choose the default selection.

To run the software, you need the administrator privilege and the basic computer requirement is as follows:

- 1) Pentium 4 CPU
- 2) Windows 2000, XP
- 3) 100M bytes free space in hard drive
- 4) 512M Memory
- 5) For the details of the software installation and the minimum computer requirement, please refer to the software manual.

6.2 Setup the User Accounts for the Software

A *User* of Flex series access control software is a person who operates the software at any user interface. Each user belongs to a certain authority group. The authority group defines the authority level of users over the operations in the software. Different authority groups have the different access to the operations in the software.

The first step to use the software is to setup a user list that defines who will be able to use the software, and assign the authority group to each user. User name and password will be required to login the software.

Please note that a user in admin group is required to configure all the other settings. For the details to setup a user account, please refer to the software manual.

6.3 Configure the Controller and All Other Hardware

In this step, user needs to set all the configurations for the controllers, doors, readers and alarms. All these configurations are closely related to the hardware. A brief introduction is described as below.

6.3.1 Add a Controller to the System

Go to the controller configuration dialog box in the software. Click the 'add' button, give the RS485 address for the controller, set the serial port for the controller and click the submit button to connect a controller.

If the wiring is correct and the address of the controller is valid, the software should be able to find the controller and show the status of the controller as 'online'. This indicates that the controller has been added to the system.

6.3.2 Configure the door Settings

This step configures door name, door open time and door-held-open time.

Door name is used to help users remember the door location and help make the configuration process easier.

Door open time defines the amount of time that the door can remain open after the door is unlocked, before an alarm is generated by the controller.

For more detailed information on door settings, please refer to the chapter in this manual entitled “Door Setting”.

6.3.3 Configure the Reader Settings

Users can configure the following properties of the readers: the reader-to-door allocation, the keypad reader and the system reader. For the more details about the reader settings, please refer to chapter 5.

On the EverAccess Flex II single-door controller, readers can set to enter or exit the door. Set these properties following the system access control plan.

Keypad Settings define whether the reader is a keypad reader. The System Reader can be used to enroll card easily.

6.3.4 Configure the Alarm Setting

All of the alarm inputs can be assigned to the different alarm outputs. Also users can set the events that can trigger alarm outputs.

6.4 Configure the Holidays, Access Group and Door Control Schedule

At this step, users will configure the holidays, access groups and the door control schedule.

6.4.1 Configure the Holidays

Users can add or delete holidays in the software. Beside holidays, two additional types of dates are supplied in the system. Different access rules can be applied to different dates.

6.4.2 Configure the Access Group

An access group defines a group of cardholders who share the same access rules at the associated access points and at specified times. Set the access rules for the access group first and then assign the cardholder to a certain access group.

6.4.3 Configure the Door Control Schedule

On the Flex II series controller, the door can be configured as normally open, card, card or PIN, card and PIN and normally closed which means, respectively, the door will remain open, a valid card has to be presented, a card or PIN has to be presented, both a valid card and a PIN have to be presented, and the door will remain closed. Please refer to the software manual for details.

6.5 Enroll Cards

There are two ways to enroll a card:

- 1) Enter the card number manually
- 2) Present a card at the desktop reader and the card number will be added into the system automatically

The properties for each card should be defined at this time. The primary properties are cardholder name, PIN, forced PIN, and access group. Users can configure the cardholders individually or can do batch configurations if a group of cardholders share common properties.

EverFocus Electronics Corp.

Head Office

12F, No.79 Sec.1 Shin-Tai Wu
Road,
Hsi-Chi, Taipei, Taiwan
Tel : + 886-2-2698-2334
Fax : + 886-2-2698-2380

USA Office

1801 Highland Ave, Duarte,
Building
CA 91010 ,U.S.A
Tel : + 1-626-844-8888
Fax : + 1-626-844-8838

Japan Office

1809 WBG Marive East 18F,
2-6 Nakase, Mihama-ku,
Chiba city 261-7118, Japan
Tel : + 81-43-212-8188
Fax : + 81-43-297-0081

European Office

Albert-Einstein-Strasse 1,
D-46446 Emmerich, German
Tel : + 49-2822-9394-0
Fax : + 49-2822-939495

Beijing Office

Room 609, KEMAO Building,
Shangdi, Haidian, Beijing, China
Tel : + 86-10-6297-3336
Fax : + 86-10-6297-1423

 **EverAccess®**
4605XFC202002AR

V 1.0
