

# ZK-S12-A

## Starter Kit for Freescale HCS12(X) Family (112-Pin LQFP ZIF Socket)

## User's Manual

---

### 1. Introduction

---

#### Overview

The ZK-S12-A Starter Kit has been designed for the evaluation of the 112-pin LQFP Freescale HCS12(X) family and the debugging of user applications. The ZK-S12-A Starter Kit can be used as a standalone application, via its built-in USB to BDM interface, or together with an external debugger through a BDM-compatible connection.

#### Starter Kit Features

The ZK-S12-A Starter Kit features the following sections.

1. An "MCU" section containing:
  - An MC9S12DP256B microcontroller (in 112-pin LQFP package, already programmed with a demo application—in addition, you can also use any other pin-to-pin-compatible device);
  - ZIF socket for the microcontroller;



Copyright © 2005 SofTec Microsystems®  
DC01132

#### SofTec Microsystems

E-mail (general information): [info@softecmicro.com](mailto:info@softecmicro.com)

E-mail (marketing department): [marketing@softecmicro.com](mailto:marketing@softecmicro.com)

E-mail (technical support): [support@softecmicro.com](mailto:support@softecmicro.com)

Web: <http://www.softecmicro.com>

#### Important

SofTec Microsystems reserves the right to make improvements to its products, their documentation and software routines, without notice. Information in this manual is intended to be accurate and reliable. However, SofTec Microsystems assumes no responsibility for its use; nor for any infringements of rights of third parties which may result from its use.

SOFTEC MICROSYSTEMS WILL NOT BE LIABLE FOR DAMAGES RESULTING FROM LOSS OF DATA, PROFITS, USE OF PRODUCTS, OR INCIDENTAL OR CONSEQUENTIAL DAMAGES, EVEN IF ADVISED OF THE POSSIBILITY THEREOF.

#### Trademarks

Freescale™ and the Freescale logo are trademarks of Freescale Semiconductor, Inc.

Metrowerks and CodeWarrior are trademarks or registered trademarks of Metrowerks Corp.

Metrowerks is a wholly-owned subsidiary of Freescale Semiconductor.

Microsoft and Windows are trademarks or registered trademarks of Microsoft Corporation.

PC is a registered trademark of International Business Machines Corporation.

Other products and company names listed are trademarks or trade names of their respective companies.

- A connector area to access the I/O pins of the microcontroller for expansion prototyping;
  - Three clock sources: a provision for a clock module, a 16 MHz crystal in Pierce configuration and a 16 MHz crystal in Colpitts configuration, selectable via the “**OSC SEL**” and “**XLCK#=0**” jumpers;
  - A jumper (“**XFC SEL**”) allowing either the provided RC loop filter (needed for the microcontroller’s internal PLL) or a user-made RC loop filter to be enabled;
  - Two jumpers (“**VRH SEL**” and “**VRL SEL**”) which allow the high and low voltage reference for the MCU internal A/D converter to be defined;
  - A “**VREGEN**” jumper allowing the on-chip voltage regulator to be enabled or disabled;
  - Two jumpers (“**MODA=1**” and “**MODB=1**”) which allow the MCU operating mode upon reset to be defined.
2. A “POWER SUPPLY” section which accepts a 12 V DC voltage (used for the LIN and CAN transceivers) and, thanks to the built-in switching power supply, provides a regulated VDD voltage for the rest of the board. A jumper (“**VDD SEL**”) allows two different microcontroller VDD voltages (3.3 V or 5.0 V) to be selected. An additional linear power supply regulator provides the 5.0 V voltage required by the “USB TO BDM INTERFACE” section.
  3. A built-in “USB TO BDM INTERFACE” section which allows the host PC to communicate with the microcontroller through a standard USB interface. USB 2.0 is fully supported. When using an external in-circuit debugger (via the BDM connector), the “USB TO BDM INTERFACE” circuitry must be bypassed by removing the “**RESET ENA**” and “**BKGD ENA**” jumpers.
  4. A standard BDM connector for in-circuit debugging/programming;
  5. A “RESET” section containing the reset supervisor circuitry and a push-button connected to the MCU Reset pin. The reset supervisor circuitry (enabled by default) can be disabled by removing the “**LVD ENA**” jumper.
  6. An “INPUTS” section containing:
    - Four push-buttons, connected to PP0, PP1, PP2 and PP3;
    - Eight general-purpose DIP-switches connected to Port T;
    - A potentiometer, together with a jumper to connect/disconnect to/from PAD00.
  7. An “OUTPUTS” section containing eight high-efficiency (low-current) LEDs connected to Port B, together with eight jumpers to connect/disconnect each of the eight LEDs to/from their respective Port B pins.
  8. A “RS-232” section providing two RS-232 channels connected to the microcontroller’s SCI0 and SCI1 serial communication interfaces. Each RS-232 channel can be configured as DTE (Data Transmission Equipment) or DCE (Data Communication Equipment) via the relative jumper (“**RS-232 x DTE/DCE SEL**”). The microcontroller’s RX and TX lines used by the RS-232 transceivers are shared with the LIN transceivers’ RX and TX lines, respectively. Use the “**RXDx SEL**” and “**TXDx SEL**” jumpers in the “SERIAL

- SETTINGS” section of the board to select whether to use the RS-232, LIN, or to free the microcontroller’s RX and TX lines. Two 9-pin, D-Sub female connectors are provided for each RS-232 channel.
9. The “LIN” section contains two LIN transceivers, each capable of a speed of up to 100 Kbps in fast mode. Every LIN node can be configured as a master node via its respective “**MASTER NODEx ENA**” jumper, which inserts a 900 Ohm resistor between the LIN bus line and the LIN transceiver power supply line. The LIN transceivers can be powered either by the Starter Kit’s internal 12 V DC reference, or by the LIN network itself, via the “**TRANSCIEVER SUPPLY SEL**” jumper. Analogously, the LIN network can be supplied by the Starter Kit’s internal 12 V DC reference via the “**LIN SUPPLY ENA**” jumper. The microcontroller’s RX and TX lines used by the LIN transceivers are shared with the RS-232 transceivers’ RX and TX lines, respectively. Use the “**RxDx SEL**” and “**TxDx SEL**” jumpers in the “SERIAL SETTINGS” section of the board to select whether to use the RS-232, LIN, or to free the microcontroller’s RX and TX lines associated with these nodes. Two 3x1 male header connectors are provided to interface to an external LIN bus.
  10. The “SERIAL SETTINGS” section has four jumpers that allow the uses of the SCI0 and SCI1 peripherals of the microcontroller to be chosen. The SCI0 peripheral can be connected to the LIN0 node or to the RS-232 channel 0, or can be freed by removing all jumpers. The SCI1 peripheral can be connected to the LIN1 node or to the RS-232 channel 1, or can be freed by removing all jumpers.
  11. The “CAN” section contains two fault-tolerant (up to 125 Kbaud) CAN transceivers. The TX and RX signals of CAN nodes CAN0 and CAN4 can be disconnected (by removing the respective “**CANx TX ENA**” and “**CANx RX ENA**” jumpers) from the microcontroller’s respective pins. Two 3x1 male header connectors are provided to interface to an external CAN bus.
  12. A prototype area features both a standard, thru-hole area (for mounting traditional components) and a SMD area (for soldering SMD components). Additionally, all of the board’s supply lines (12 V, 5 V, VDD and GND lines) are provided.

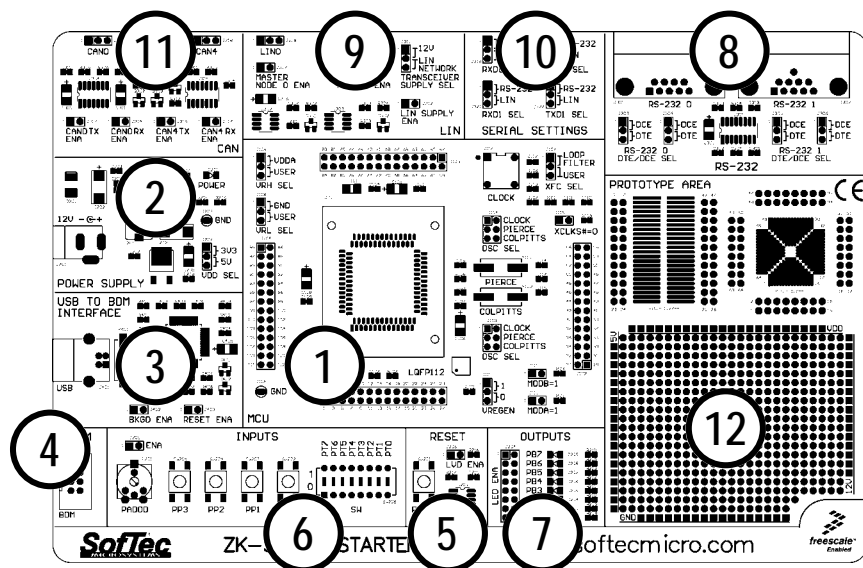

The ZK-S12-A Starter Kit

## Supported Devices

The ZK-S12-A Starter Kit supports the following devices:

- MC9S12A family;
- MC9S12B family;
- MC9S12D family;
- MC9S12DB/DG/DJ/DP/DT family;
- MC9S12KC/KG/KL/KT family;
- MC9S12XDP/DT family (S12X core);
- And any future pin-to-pin compatible device.

**Note:** *the MC9S12XDP/DT family (S12X core) requires a special version of CodeWarrior Development Studio (CodeWarrior Development Studio for HC9S12X/XGATE).*

## Recommended Reading

- Freescale HCS12 microcontroller-specific datasheets;
- SK-S12(X) and ZK-S12(X) Series Starter Kit User's Manual;
- ZK-S12-A Schematic.

## 2. Device Configuration

### Oscillator Configuration

Thanks to the 112-pin LQFP ZIF socket, the ZK-S12-A Starter Kit can support different devices, as detailed in the table below.

All of the jumpers in the "MCU" section of the board must be set according to the specific microcontroller installed. Particular care must be taken in order to correctly set the oscillator configuration.

Device	Pierce Configuration		Colpitts Configuration		Clock	
	"OSC SEL" Jumpers	"XCLKS#=0" Jumper	"OSC SEL" Jumpers	"XCLKS#=0" Jumper	"OSC SEL" Jumpers	"XCLKS#=0" Jumper
MC9S12A64	"PIERCE"	Installed	"COLPITTS"	Not Installed	"CLOCK"	Installed
MC9S12A128	"PIERCE"	Installed	"COLPITTS"	Not Installed	"CLOCK"	Installed
MC9S12A256	-	-	"COLPITTS"	Not Installed	"CLOCK"	Installed
MC9S12A512	"PIERCE"	Installed	"COLPITTS"	Not Installed	"CLOCK"	Installed
MC9S12B64	"PIERCE"	Installed	"COLPITTS"	Not Installed	"CLOCK"	Installed
MC9S12B128	"PIERCE"	Installed	"COLPITTS"	Not Installed	"CLOCK"	Installed
MC9S12D64	"PIERCE"	Installed	"COLPITTS"	Not Installed	"CLOCK"	Installed
MC9S12DB128	"PIERCE"	Installed	"COLPITTS"	Not Installed	"CLOCK"	Installed
MC9S12DG128	"PIERCE"	Installed	"COLPITTS"	Not Installed	"CLOCK"	Installed
MC9S12DG256	-	-	"COLPITTS"	Not Installed	"CLOCK"	Installed
MC9S12DJ64	"PIERCE"	Installed	"COLPITTS"	Not Installed	"CLOCK"	Installed
MC9S12DJ128	"PIERCE"	Installed	"COLPITTS"	Not Installed	"CLOCK"	Installed
MC9S12DJ256	-	-	"COLPITTS"	Not Installed	"CLOCK"	Installed
MC9S12DJ512	"PIERCE"	Installed	"COLPITTS"	Not Installed	"CLOCK"	Installed
MC9S12DP256	-	-	"COLPITTS"	Not Installed	"CLOCK"	Installed
MC9S12DP512	"PIERCE"	Installed	"COLPITTS"	Not Installed	"CLOCK"	Installed
MC9S12DT128	"PIERCE"	Installed	"COLPITTS"	Not Installed	"CLOCK"	Installed
MC9S12DT256	-	-	"COLPITTS"	Not Installed	"CLOCK"	Installed
MC9S12DT512	"PIERCE"	Installed	"COLPITTS"	Not Installed	"CLOCK"	Installed
MC9S12KG128	"PIERCE"	Installed	-	-	"CLOCK"	Installed

Device	Pierce Configuration		Colpitts Configuration		Clock	
	"OSC SEL" Jumpers	"XCLKS#=0" Jumper	"OSC SEL" Jumpers	"XCLKS#=0" Jumper	"OSC SEL" Jumpers	"XCLKS#=0" Jumper
MC9S12KT256	"PIERCE"	Installed	-	-	"CLOCK"	Installed
MC9S12XDP512	"PIERCE"	Installed	-	-	"CLOCK"	Installed



### Peripherals







Some devices do not feature the same number of CAN and SCI peripherals. Please refer to the table below for details.

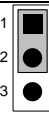

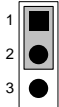

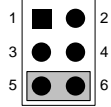
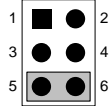
Device	CAN0	CAN1	CAN2	CAN3	CAN4	SCI0	SCI1
MC9S12A64						✓	✓
MC9S12A128						✓	✓
MC9S12A256						✓	✓
MC9S12A512						✓	✓
MC9S12B64	✓					✓	✓
MC9S12B128	✓					✓	✓
MC9S12D64	✓					✓	✓
MC9S12DB128	✓				✓	✓	✓
MC9S12DG128	✓				✓	✓	✓
MC9S12DG256	✓				✓	✓	✓
MC9S12DJ64	✓					✓	✓
MC9S12DJ128	✓				✓	✓	✓
MC9S12DJ256	✓				✓	✓	✓
MC9S12DJ512	✓				✓	✓	✓
MC9S12DP256	✓	✓	✓	✓	✓	✓	✓
MC9S12DP512	✓	✓	✓	✓	✓	✓	✓
MC9S12DT128	✓	✓			✓	✓	✓
MC9S12DT256	✓	✓			✓	✓	✓
MC9S12DT512	✓	✓			✓	✓	✓
MC9S12KG128	✓				✓	✓	✓
MC9S12KT256	✓	✓			✓	✓	✓
MC9S12XDP512	✓	✓	✓	✓	✓	✓	✓

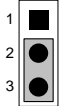
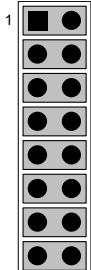

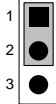
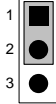
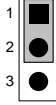
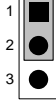

## 3. Summary of Jumper and Connector Settings

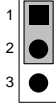
### Jumpers Summary

Name	Reference	Description/Pinout
J105		<b>VRH SELECTION</b>  <b>1-2 (VDDA)</b> <b>VRH tied to VDDA (default)</b> <b>2-3 (USER)</b> VRH connected to the J103 connector
J106		<b>VRL SELECTION</b>  <b>1-2 (GND)</b> <b>VRL tied to ground (default)</b> <b>2-3 (USER)</b> VRL connected to the J104 connector
J107		<b>XFC SELECTION</b>  <b>1-2 (LOOP FILTER)</b> <b>The on-board RC PLL loop filter is selected (default)</b>  <b>2-3 (USER)</b> The XFC PLL loop filter pin is connected to signal pin connector



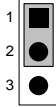
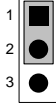
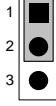
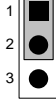



Name	Reference	Description/Pinout
J109		<b>VOLTAGE REGULATOR ENABLE</b>  1-2 (1) <b>Microcontroller internal voltage regulator enabled (default)</b> 2-3 (0)      Microcontroller internal voltage regulator disabled. VDD1, VDD2 and VDDPLL must be supplied externally.
J110		<b>MODA=1</b>  Installed      MODA line pulled to VDD Not Installed <b>MODA line tied to ground by internal pull down (default)</b>
J111		<b>MODB=1</b>  Installed      MODB line pulled to VDD Not Installed <b>MODB line tied to ground by internal pull down (default)</b>
J113		<b>OSCILLATOR SELECTION</b>  1-2 (CLOCK)      Clock selected 3-4 (PIERCE)      Pierce crystal configuration selected <b>5-6 (COLPITTS) Colpitts crystal configuration selected (default)</b>
J114		<b>OSCILLATOR SELECTION</b>  1-2 (CLOCK)      Clock selected 3-4 (PIERCE)      Pierce crystal configuration selected <b>5-6 (COLPITTS) Colpitts crystal configuration selected (default)</b>
J115		<b>XCLKS#=0</b>  Installed      XCLKS# pin pushed to ground. Full-swing Pierce crystal configuration or clock selected. Not Installed <b>XCLKS# pulled to VDD. Loop controlled Colpitts crystal configuration selected. (default)</b>
J202		<b>VDD SELECTION</b>  1-2 (3V3)      VDD = 3.3 V 2-3 (5V) <b>VDD = 5 V (default)</b>
J204		<b>LED ENABLE</b>  Installed <b>The LEDs are connected to the PB[7..0] port of the microcontroller (default)</b> Not Installed      The LEDs are not connected to the microcontroller.
J205		<b>POTENTIOMETER ENABLE</b>  Installed: <b>The potentiometer is connected to the microcontroller's AN00 pin (default)</b> Not Installed:      The potentiometer is not connected to the microcontroller

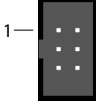

Name	Reference	Description/Pinout
J206		<b>LVD ENABLE</b>  <b>Installed:</b> <b>The LVD circuit is connected to microcontroller's RESET line (default)</b> <b>Not Installed:</b> The LVD circuit is not connected to RESET line of the microcontroller
J303		<b>RS-232 0 DTE/DCE SELECTION</b>  <b>1-2 (DCE)</b> <b>The RS-232 channel 0 is configured as DCE (default)</b> <b>2-3 (DTE)</b> The RS-232 channel 0 is configured as DTE
J304		<b>RS-232 0 DTE/DCE SELECTION</b>  <b>1-2 (DCE)</b> <b>The RS-232 channel 0 is configured as DCE (default)</b> <b>2-3 (DTE)</b> The RS-232 channel 0 is configured as DTE
J305		<b>RS-232 1 DTE/DCE SELECTION</b>  <b>1-2 (DCE)</b> <b>The RS-232 channel 1 is configured as DCE (default)</b> <b>2-3 (DTE)</b> The RS-232 channel 1 is configured as DTE
J306		<b>RS-232 1 DTE/DCE SELECTION</b>  <b>1-2 (DCE)</b> <b>The RS-232 channel 1 is configured as DCE (default)</b> <b>2-3 (DTE)</b> The RS-232 channel 1 is configured as DTE
J307		<b>MASTER NODE 0 ENABLE</b>  <b>Installed</b> <b>LIN0 master node (default)</b> <b>Not Installed</b> LIN0 slave node
J309		<b>MASTER NODE 1 ENABLE</b>  <b>Installed</b> <b>LIN1 master node (default)</b> <b>Not Installed</b> LIN1 slave node
J311		<b>LIN TRANSCEIVER SUPPLY SELECTION</b>  <b>1-2 (12V)</b> <b>LIN transceivers are supplied by the Starter Kit's internal 12 V DC voltage (default)</b> <b>2-3 (LIN NETWORK)</b> LIN transceivers supplied by the LIN bus' VBAT line
J312		<b>LIN SUPPLY ENABLE</b>  <b>Installed</b> <b>LIN bus is powered by the Starter Kit's internal 12 V DC voltage (default)</b> <b>Not Installed</b> LIN bus is self-powered
J313		<b>CAN0 TX ENABLE</b>  <b>Installed</b> <b>Microcontroller's PM1/TXCAN0 pin connected to CAN0 transceiver (default)</b> <b>Not Installed</b> Microcontroller's PM1/TXCAN0 pin floating

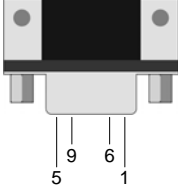
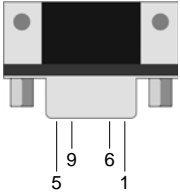
Name	Reference	Description/Pinout
J314		<b>CAN0 RX ENABLE</b>  <b>Installed</b> <b>Microcontroller's PM0/RXCAN0 pin connected to CAN0 transceiver (default)</b> <b>Not Installed</b> Microcontroller's PM0/RXCAN0 pin floating
J316		<b>CAN4 TX ENABLE</b>  <b>Installed</b> <b>Microcontroller's PJ7/TXCAN4 pin connected to CAN4 transceiver (default)</b> <b>Not Installed</b> Microcontroller's PJ7/TXCAN4 pin floating
J317		<b>CAN4 RX ENABLE</b>  <b>Installed</b> <b>Microcontroller's PJ6/RXCAN4 pin connected to CAN4 transceiver (default)</b> <b>Not Installed</b> Microcontroller's PJ6/RXCAN4 pin floating
J319		<b>RXD0 SELECTION</b>  <b>1-2 (RS-232)</b> <b>Microcontroller's PS0/RXD0 pin connected to RS-232 0 transceiver (default)</b> <b>2-3 (LIN)</b> Microcontroller's PS0/RXD0 pin connected to LIN0 transceiver
J320		<b>TXD0 SELECTION</b>  <b>1-2 (RS-232)</b> <b>Microcontroller's PS1/TXD0 pin connected to RS-232 0 transceiver (default)</b> <b>2-3 (LIN)</b> Microcontroller's PS1/TXD0 pin connected to LIN0 transceiver
J321		<b>RXD1 SELECTION</b>  <b>1-2 (RS-232)</b> <b>Microcontroller's PS2/RXD1 pin connected to RS-232 1 transceiver (default)</b> <b>2-3 (LIN)</b> Microcontroller's PS2/RXD1 pin connected to LIN1 transceiver
J322		<b>TXD1 SELECTION</b>  <b>1-2 (RS-232)</b> <b>Microcontroller's PS3/TXD1 pin connected to RS-232 1 transceiver (default)</b> <b>2-3 (LIN)</b> Microcontroller's PS3/TXD1 pin connected to LIN1 transceiver
J402		<b>BKGD ENABLE</b>  <b>Installed</b> <b>Microcontroller's BKGD line connected to the "USB TO BDM INTERFACE" (default)</b> <b>Not Installed</b> Microcontroller's BKGD line not connected to the "USB TO BDM INTERFACE"
J403		<b>RESET ENABLE</b>  <b>Installed</b> <b>Microcontroller's RESET# line connected to the "USB TO BDM INTERFACE" (default)</b> <b>Not Installed</b> Microcontroller's RESET# line not connected to the "USB TO BDM INTERFACE"



## Connectors Summary/Pinout

Name	Reference	Description/Pinout
J101, J102, J103, J104		<b>MCU I/O Connectors</b>  See schematic for pin explanation
J108		<b>Ground Test Point</b>
J112		<b>BDM Connector</b>  <ol style="list-style-type: none"> <li>1. BKGD</li> <li>2. GND</li> <li>3. N.C.</li> <li>4. RESET#</li> <li>5. N.C.</li> <li>6. VDD</li> </ol>
J201		<b>12 V DC Power Supply Input Connector</b>  <ol style="list-style-type: none"> <li>1. 12 V DC</li> <li>2. GND</li> </ol>
J203		<b>Ground Test Point</b>
J301		<b>RS-232 0 Connector</b>  <ol style="list-style-type: none"> <li>1. N.C.</li> <li>2. TX or RX (see J303/J304 jumpers)</li> <li>3. RX or TX (see J303/J304 jumpers)</li> <li>4. N.C.</li> <li>5. GND</li> <li>6. N.C.</li> <li>7. N.C.</li> <li>8. N.C.</li> <li>9. N.C.</li> </ol>
J302		<b>RS-232 1 Connector</b>  <ol style="list-style-type: none"> <li>1. N.C.</li> <li>2. TX or RX (see J305/J306 jumpers)</li> <li>3. RX or TX (see J305/J306 jumpers)</li> <li>4. N.C.</li> <li>5. GND</li> <li>6. N.C.</li> <li>7. N.C.</li> <li>8. N.C.</li> <li>9. N.C.</li> </ol>
J308		<b>LIN0 Connector</b>  <ol style="list-style-type: none"> <li>1. VBAT – LIN Bus Power Supply</li> <li>2. LIN – LIN Signal</li> <li>3. GND</li> </ol>
J310		<b>LIN1 Connector</b>  <ol style="list-style-type: none"> <li>1. VBAT – LIN Bus Power Supply</li> <li>2. LIN – LIN Signal</li> <li>3. GND</li> </ol>
J315		<b>CAN0 Connector</b>  <ol style="list-style-type: none"> <li>1. CANH – CAN Differential Bus Line</li> <li>2. GND</li> <li>3. CANL – CAN Differential Bus Line</li> </ol>

Name	Reference	Description/Pinout
J318		<b>CAN4 Connector</b> <ol style="list-style-type: none"><li>1. CANH – CAN Differential Bus Line</li><li>2. GND</li><li>3. CANL – CAN Differential Bus Line</li></ol>
J401		<b>USB Connector</b> <ol style="list-style-type: none"><li>1. 5 V DC USB Bus Power Supply Line</li><li>2. USB D-</li><li>3. USB D+</li><li>4. GND</li></ol>