

1 YEAR
WARRANTY

CAUTION! – This product
is not intended for medical
use or use on humans

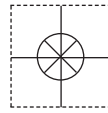

Ω OMEGA[®] **User's Guide**



***Shop online at
omega.com[®]***

e-mail: info@omega.com
***For latest product manuals:
omegamanual.info***

ISO 9001
CERTIFIED
CORPORATE QUALITY
STAMFORD, CT

ISO 9001
CERTIFIED
CORPORATE QUALITY
MANCHESTER, UK

OS136 SERIES **Miniature Low-Cost** **Non-Contact Infrared** **Temperature Sensor/Transmitter**



OMEGAnet® Online Service
omega.com

Internet e-mail
info@omega.com

Servicing North America:

U.S.A.:
ISO 9001 Certified

Omega Engineering, Inc., One Omega Drive, P.O. Box 4047
Stamford, CT 06907-0047 USA

Toll Free: 1-800-826-6342
FAX: (203) 359-7700

TEL: (203) 359-1660
e-mail: info@omega.com

Canada:

976 Bergar
Laval (Quebec), H7L 5A1 Canada

Toll-Free: 1-800-826-6342
FAX: (514) 856-6886

TEL: (514) 856-6928
e-mail: info@omega.ca

For immediate technical or application assistance:

U.S.A. and Canada: Sales Service: 1-800-826-6342/1-800-TC-OMEGA®
Customer Service: 1-800-622-2378/1-800-622-BEST®
Engineering Service: 1-800-872-9436/1-800-USA-WHEN®

**Mexico/
Latin America:**

En Español: 001 (203) 359-7803
info@omega.com.mx

FAX: 001 (203) 359-7807
e-mail: espanol@omega.com

Servicing Europe:

Benelux:

Managed by the United Kingdom Office
Toll-Free: 0800 099 3344
FAX: +31 20 643 46 43

TEL: +31 20 347 21 21
e-mail: sales@omegaeng.nl

Czech Republic:

Frystatska 184
733 01 Karviná, Czech Republic
Toll-Free: 0800-1-66342
FAX: +420-59-6311114

TEL: +420-59-6311899
e-mail: info@omegashop.cz

France:

Managed by the United Kingdom Office
Toll-Free: 0800 466 342
FAX: +33 (0) 130 57 54 27

TEL: +33 (0) 161 37 29 00
e-mail: sales@omega.fr

Germany/Austria:

Daimlerstrasse 26
D-75392 Deckenpfronn, Germany
Toll-Free: 0800 6397678
FAX: +49 (0) 7056 9398-29

TEL: +49 (0) 7056 9398-0
e-mail: info@omega.de

United Kingdom:
ISO 9001 Certified

OMEGA Engineering Ltd.
One Omega Drive, River Bend Technology Centre, Northbank
Irlam, Manchester M44 5BD United Kingdom
Toll-Free: 0800-488-488
FAX: +44 (0) 161 777-6622

TEL: +44 (0) 161 777-6611
e-mail: sales@omega.co.uk

It is the policy of OMEGA Engineering, Inc. to comply with all worldwide safety and EMC/EMI regulations that apply. OMEGA is constantly pursuing certification of its products to the European New Approach Directives. OMEGA will add the CE mark to every appropriate device upon certification.

The information contained in this document is believed to be correct, but OMEGA accepts no liability for any errors it contains, and reserves the right to alter specifications without notice.

WARNING: These products are not designed for use in, and should not be used for, human applications.



Table of Contents

Section	Page
Caution and Safety Information	iii
Safety Warnings and IEC Symbols	iii
Section 1 Introduction	1
Section 2 Installation	1
2.1 Unpacking	1
2.2 Electrical Connection	2
Section 3 Operation	3
3.1 Measuring Temperature	3
3.2 Ambient Temperature	3
3.3 Atmospheric Quality	4
Section 4 Laser Sight Accessory	6
4.1 Warnings and Caution	6
4.2 Operating the Laser Sight Accessory	6
Section 5 Specifications	8
5.1 General	8
5.2 Laser Sight Accessory	9



List of Figures

Figure	Description	Page
2-1	General Wiring Diagram	2
3-1	Optical Field of View	3
3-2	Mounting Bracket, OS100-MB	4
3-3	Air Purge Collar, OS100-AP	4
3-4	Stainless Steel Housing	5
3-5	Water/Air Cool Jacket, OS136-WC	5
3-6	Water/Air Cool Jacket Assembly	5
4-1	Laser Sighting Accessory, OS100-LS	7
4-2	Laser Warning Label.....	7

CAUTION & SAFETY INFORMATION

If the equipment is used in a manner not specified in this manual, the protection provided by the equipment may be impaired.

The Installation category is one (1).

There is no user replaceable fuse in this product.

The output terminals of this product are for use with equipment (Digital meters, chart recorders, etc.) which have no accessible live parts. Such equipment should comply with all the applicable safety requirements.

Do not operate the equipment in flammable or explosive environments.

The unit comes with a 1.82 m (6') shielded cable for power and output connections. The cable is a multi-conductor, 24 AWG stranded wire with the rating of 600 VDC, 205°C, (401°F) Teflon® insulation.

Power must be disconnected before making any electrical connections.

The recommended power supply should be VDE or UL approved. Rating:12-24 VDC @ 50 mA min. power with overload protection.

The supply voltage to the transmitter should not exceed 24 VDC.

SAFETY WARNINGS AND IEC SYMBOLS

This device is marked with international safety and hazardous symbols in accordance with IEC1010. It is important to read and follow all the precautions and instructions in this manual before operating or commissioning this device as it contains important information relating to safety and EMC. Failure to follow all the safety precautions may result in injury and/or damage to your equipment.

IEC Symbol

Description



Caution - Refer to the accompanying document(s).



Direct Current



Laser Symbol

SECTION 1 - INTRODUCTION

The model OS136 series is a very low-cost, super-compact infrared transmitter. It measures temperature via non-contact, and provides an analog output proportional to the measured temperature. The OS136 series is offered in two temperature ranges: -18 to 204°C (0 to 400°F) and 149 to 538°C (300 to 1000°F). The analog output is offered as 4 to 20 mA, 0 to 5 Vdc, 0 to 10 Vdc, 10 mV/Degree C or F, or K type thermocouple.

The unit has a fixed Emissivity of 0.95 which makes it easy to measure temperature, requiring no adjustments during installation and use.

The super-compact design, 19 mm OD x 89 mm Length (0.75" OD x 3.5" L) is ideal to measure temperature in confined, and hard to reach places. The Stainless Steel housing is NEMA-4 rated. The unit comes with a 1.82 m (6') shielded cable as standard.

SECTION 2 – INSTALLATION

2.1 – Unpacking

Remove the packing list and verify that you have received all your equipment. If you have any questions about the shipment, please call the Customer Service at:

1-800-622-2378 or 203-359-2208. We can also be reached on the internet at

omega.com

email: cservice@omega.com

When you receive the shipment, inspect the container and the equipment for any signs of damage. Note any evidence of rough handling in transit. Immediately report any damage to the shipping agent.

NOTE:

The carrier will not honor any damage claims unless all the shipping materials are saved for inspection. After examination and removing contents, save packing material and carton in the event reshipment is necessary.

The following items are supplied in the box:

- The infrared transmitter, OS136 with the 1.82 m (6') shielded cable.
- Two Mounting Nuts
- User's Guide

The following describes the ordering information:

OS136 - * - ** , where

- * means:

-1 : -18 to 204°C (0 to 400°F) Temperature range

-2 : 149 to 538°C (300 to 1000°F) Temperature range

- ** means:

-MA : 4 to 20 mA current output

-V1 : 0 to 5 Vdc output

-V2 : 0 to 10 Vdc output

-K : K type thermocouple output

-MVC : 10 mV/°C output

-MVF : 10 mV/°F output

The following table lists the optional accessories:

Accessories	
Model No.	Description
OS100-MB	Mounting Bracket
OS136-WC	Water/Air Cooling Jacket
OS100-AP	Air Purge Collar
OS100-LS	Laser Sighting
PSU-93	Unregulated 16-24 VDC Power Supply
CAL-3-IR	NIST Traceable Calibration

2.2 – Electrical Connection

The shielded cable provides the power and output connections. Fig 2-1 shows the wiring diagram for different analog outputs.

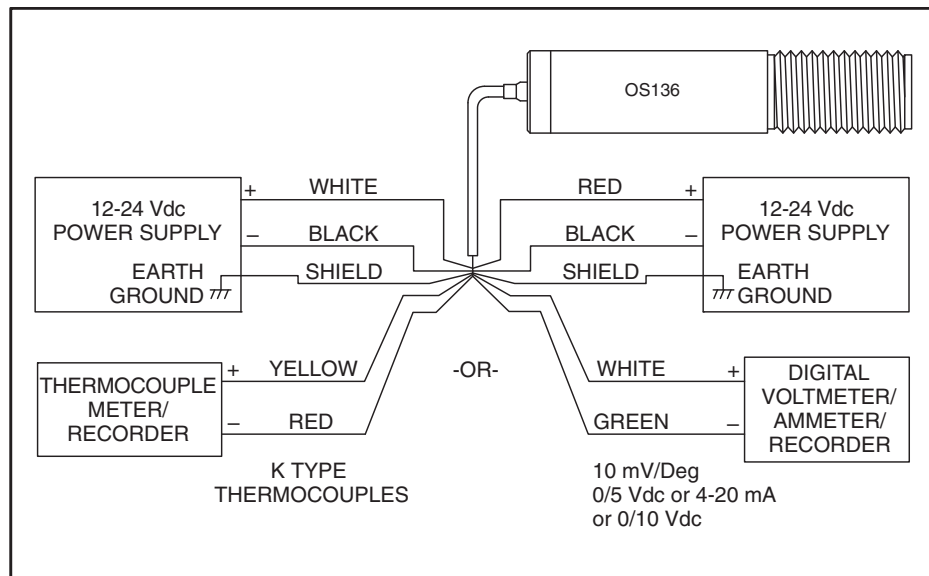

Figure 2-1. General Wiring Diagram

SECTION 3 – OPERATION

3.1 – Measuring Temperature

Before starting to measure temperature, make sure the following check list is met:

- ✓ The Power and output connections are made (Fig 2-1)
- ✓ The target is larger than the optical field of view of the transmitter (Fig 3-1)
- ✓ Use the Laser Sighting accessory (Optional), to align the transmitter to the center of the target area.
- ✓ The Emissivity is fixed at 0.95. No adjustment is necessary. If the target Emissivity is less than 0.95, you can place a masking tape or paint the target area with flat black paint to raise the surface Emissivity to 0.95.
- ✓ Make sure the output load is within the product specification.

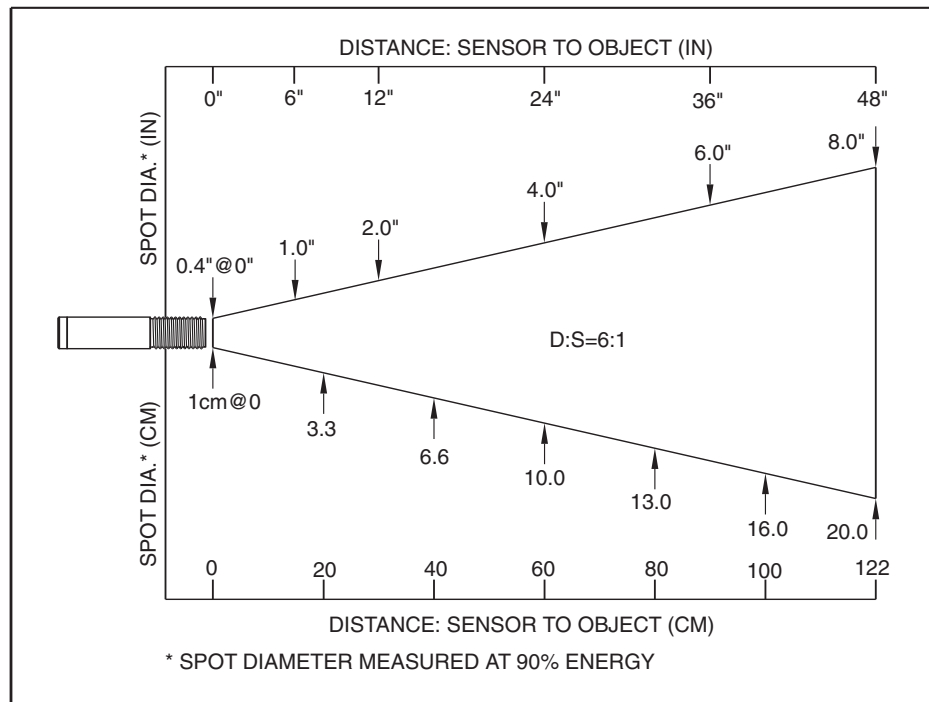

Figure 3-1. Optical Field of View

3.2 – Ambient Temperature

The transmitter can operate in an ambient temperature of 0 to 70°C (32 to 158°F) without any water cool jacket. It can operate from 0 to 200°C (32 to 392°F) with the water cool jacket accessory, OS136-WC (Fig 3-5 & 3-6). It can operate up to 110°C (230°F) with air cooling.

There is a warm up period of 1 to 2 minutes after power up. After the warm up period, temperature measurement can be made.

When the ambient temperature around the transmitter changes abruptly, the sensor head goes through a thermal shock. It takes a certain amount of time for the sensor head to get stabilized to the new ambient temperature. For example, it takes about 30 minutes for the transmitter to stabilize from 25°C to 50°C ambient temperature.

3.3 - Atmospheric Quality

Environments with smoke, dust, and fume dirty up the optical lens, and cause erroneous temperature readings. To keep the surface of the optical lens clean, the air purge collar accessory is recommended, OS136-AP (Fig 3-3).

The following figures show the Mounting Bracket (OS136-MB), Air Purge Collar (OS136-AP), Stainless Steel Housing, Water/Air Cool Jacket (OS136-WC), and the Water/Air Cool Jacket Assembly.

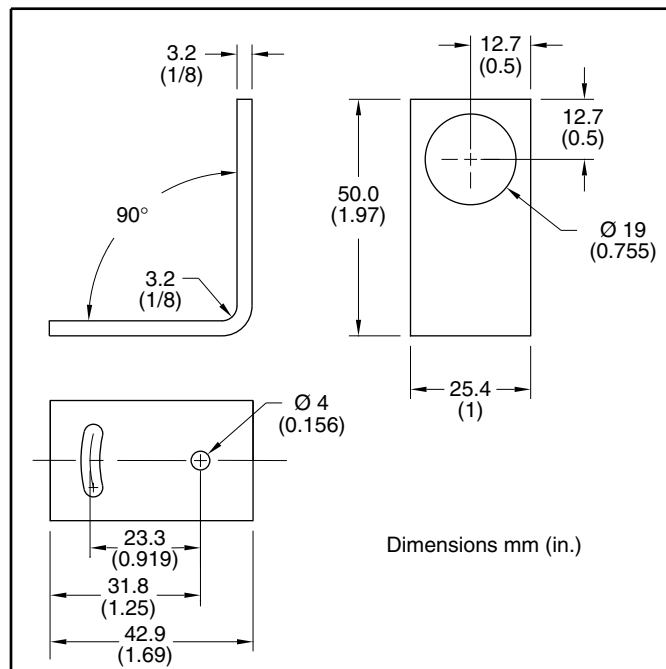

Figure 3-2. Mounting Bracket, OS100-MB

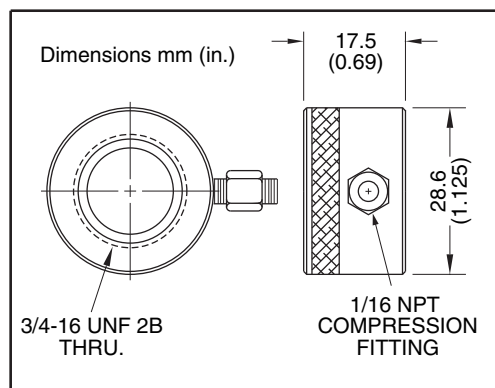

Figure 3-3. Air Purge Collar, OS100-AP

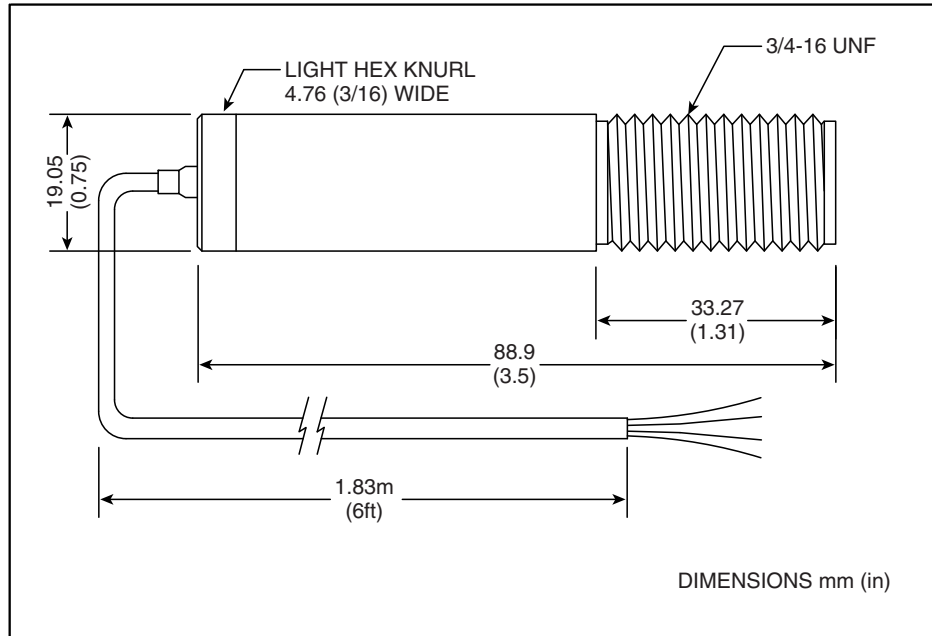

Figure 3-4. Stainless Steel Housing

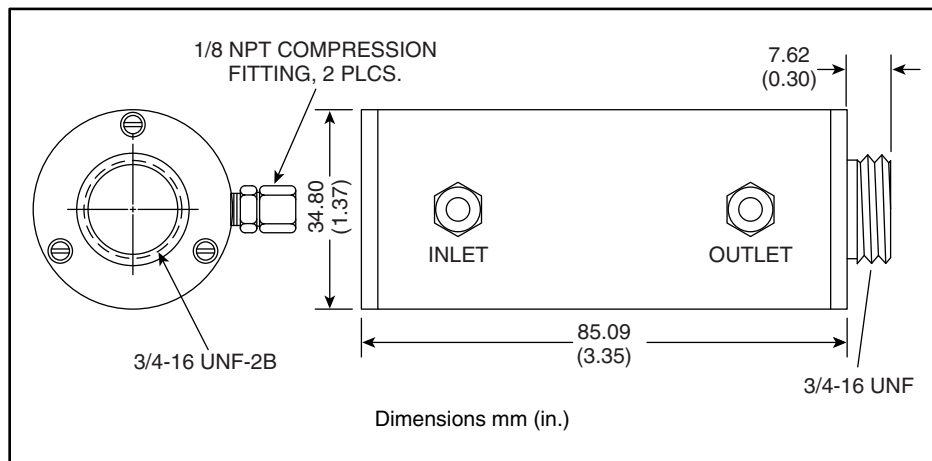

Figure 3-5. Water/Air Cool Jacket, OS136-WC

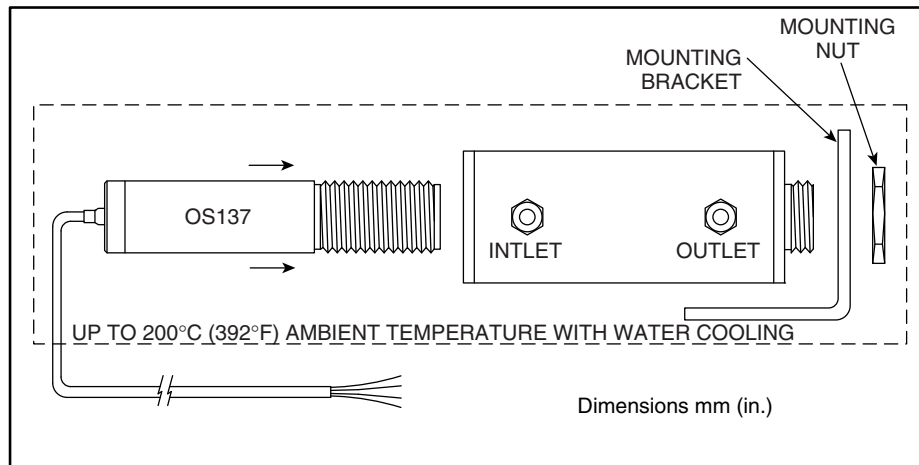

Figure 3-6. Water/Air Cool Jacket Assembly

SECTION 4 - LASER SIGHT ACCESSORY

4.1 – Warning and Caution

CAUTION:

You may receive harmful laser radiation exposure if you do not adhere to the warnings listed below:

- USE OF CONTROLS OR ADJUSTMENTS OR PERFORMANCE OF PROCEDURES OTHER THAN THOSE SPECIFIED HERE MAY RESULT IN HAZARDOUS RADIATION EXPOSURE.
- DO NOT LOOK AT THE LASER BEAM COMING OUT OF THE LENS OR VIEW DIRECTLY WITH OPTICAL INSTRUMENTS – EYE DAMAGE CAN RESULT.
- USE EXTREME CAUTION WHEN OPERATING THE LASER SIGHT ACCESSORY
- NEVER POINT THE LASER ACCESSORY AT A PERSON
- KEEP OUT OF REACH OF ALL CHILDREN

WARNING:

Do not attempt to open the laser sight accessory. There are no user serviceable parts inside.

4.2 – Operating the Laser Sight Accessory

The Laser sight accessory screws onto the front of the transmitter sensor head. This accessory is only used for alignment of the transmitter head to the target area. After the alignment process, the accessory has to be removed from the front of the transmitter head before temperature measurement is made.

The laser sight accessory is powered from a small, compact battery pack (included with the accessory). Connect the battery pack to the accessory using the cable provided. Aim at the target, and turn on the battery power using the slide switch on the battery pack. Adjust the sensor head position such that the laser beam points to the center of the target area. Turn off the battery pack, and remove the laser sighting accessory from the sensor head (Fig 4-1).

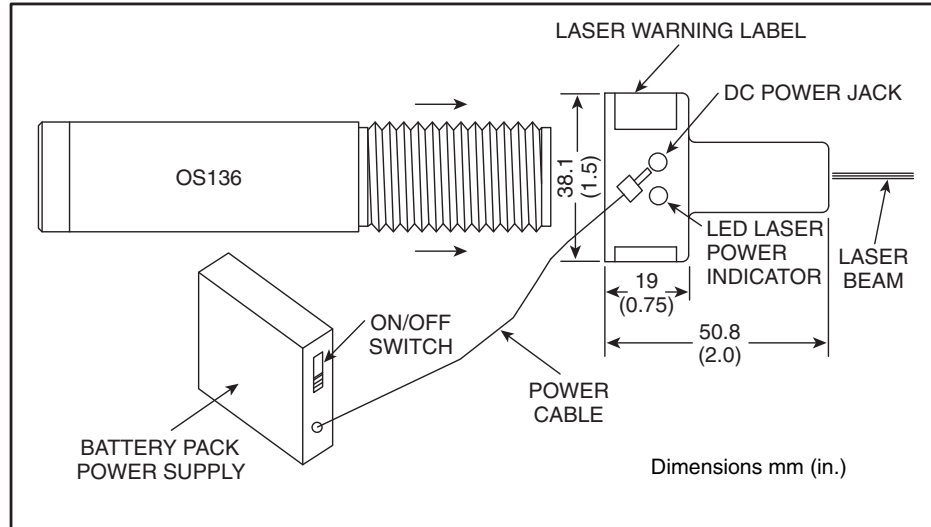

Figure 4-1. Laser Sighting Accessory, OS100-LS

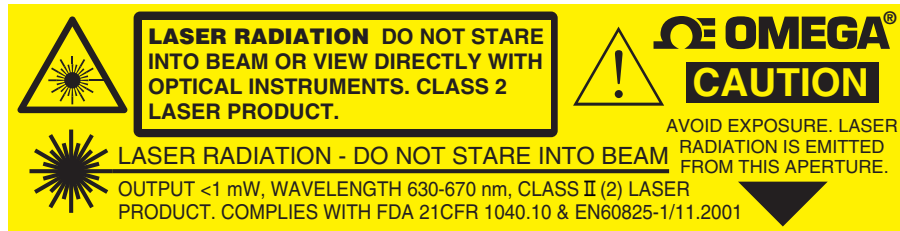

Figure 4-2. Laser Warning Label

SECTION 5 – SPECIFICATIONS

5.1 - General

Temperature Range:	
OS136-1	-18 to 204°C (0 to 400°F)
OS136-2	149 to 538°C (300 to 1000°F)
Accuracy: @22°C (72°F) ambient	
OS136-1	3% of Rdg or 4.4°C (8°F) whichever is greater
OS136-2	3% of Rdg or 5.5°C (10°F) whichever is greater From 185 to 510°C (365 to 950°F)
Repeatability:	1% of Rdg.
Optical Field of View:	6 to 1 (Distance to Spot Size)
Spectral Response:	5 to 14 microns
Response Time:	150 msec, 0 to 63% of final value
Emissivity:	Fixed at 0.95
Analog output:	
MA	4 to 20 mA
V1	0 to 5 Vdc
V2	0 to 10 Vdc
K	K type Thermocouple, compensated
MVC	10 mV/°C
MVF	10 mV/°F
Output Load Requirements:	
Min. Load (0 to 5 Vdc)	1 K-Ohms
Min. Load (0 to 10 Vdc)	2 K-Ohms
Max. Load (4 to 20 mA)	(Power Supply – 4) / 20 mA
Min. Load (10 mV/Deg)	10 K-Ohms
Min. Load (K T/C)	100 K-Ohms
Operating Ambient Temperature:	
No Water Cooling	0 to 70°C (32 to 158°F)
With Water Cooling (OS136-WC)	0 to 200°C (32 to 392°F)
With Air Cooling (OS136-WC)	0 to 110°C (32 to 230°F)
Operating Relative Humidity:	Less than 95% RH, non-condensing
Water Flow Rate for OS136-WC:	0.25 GPM, room temperature, minimum
Air Flow Rate for OS136-WC	5 CFM (2.4 liters/sec)
Warm up Period:	1 to 2 minutes
Thermal Shock:	About 30 minutes for 25°C abrupt ambient temperature change
Air Flow Rate for Air Purge Collar	1 CFM (0.5 liters/sec.)
Transmitter Housing:	Stainless Steel 316, NEMA-4 & IP65 rated
Power:	12 to 24 VDC @ 50 mA
Dimensions:	19 OD x 89 L mm (0.75" OD x 3.5" L)
Weight:	0.40 lb (181 g)

5.2 - Laser Sight Accessory

Laser Wavelength (Color):	630 - 670 nm (Red)
Operating Distance:	Up to 9.1 m (30 ft.)
Max. Laser Power Output:	Less than 1 mW @ 22°C ambient
European Classification:	Class 2, EN60825-1/11.2001
FDA Classification:	Class II Laser Product. Complies with 21 CFR 1040.10
Laser Beam Diameter:	Less than 5 mm
Beam Divergence:	Less than 2 mrad
Operating Temperature:	0 to 50°C (32 to 122°F)
Operating Relative Humidity:	Less than 95% RH, non-condensing
Power Switch:	ON/OFF, Slide switch on the Battery Pack
Power Indicator:	Red LED
Power:	Battery Pack, 3 VDC
Caution & Certification Label:	Located on the head sight circumference
Identification Label:	Located on the head sight circumference
Aperture Label:	Located on the head sight circumference
Dimensions:	38 OD x 50.8 L mm (1.5" OD x 2" L)

WARRANTY/DISCLAIMER

OMEGA ENGINEERING, INC. warrants this unit to be free of defects in materials and workmanship for a period of **13 months** from date of purchase. OMEGA's WARRANTY adds an additional one (1) month grace period to the normal **one (1) year product warranty** to cover handling and shipping time. This ensures that OMEGA's customers receive maximum coverage on each product.

If the unit malfunctions, it must be returned to the factory for evaluation. OMEGA's Customer Service Department will issue an Authorized Return (AR) number immediately upon phone or written request. Upon examination by OMEGA, if the unit is found to be defective, it will be repaired or replaced at no charge. OMEGA's WARRANTY does not apply to defects resulting from any action of the purchaser, including but not limited to mishandling, improper interfacing, operation outside of design limits, improper repair, or unauthorized modification. This WARRANTY is VOID if the unit shows evidence of having been tampered with or shows evidence of having been damaged as a result of excessive corrosion; or current, heat, moisture or vibration; improper specification; misapplication; misuse or other operating conditions outside of OMEGA's control. Components in which wear is not warranted, include but are not limited to contact points, fuses, and triacs.

OMEGA is pleased to offer suggestions on the use of its various products. However, OMEGA neither assumes responsibility for any omissions or errors nor assumes liability for any damages that result from the use of its products in accordance with information provided by OMEGA, either verbal or written. OMEGA warrants only that the parts manufactured by the company will be as specified and free of defects. OMEGA MAKES NO OTHER WARRANTIES OR REPRESENTATIONS OF ANY KIND WHATSOEVER, EXPRESSED OR IMPLIED, EXCEPT THAT OF TITLE, AND ALL IMPLIED WARRANTIES INCLUDING ANY WARRANTY OF MERCHANTABILITY AND FITNESS FOR A PARTICULAR PURPOSE ARE HEREBY DISCLAIMED. LIMITATION OF LIABILITY: The remedies of purchaser set forth herein are exclusive, and the total liability of OMEGA with respect to this order, whether based on contract, warranty, negligence, indemnification, strict liability or otherwise, shall not exceed the purchase price of the component upon which liability is based. In no event shall OMEGA be liable for consequential, incidental or special damages.

CONDITIONS: Equipment sold by OMEGA is not intended to be used, nor shall it be used: (1) as a "Basic Component" under 10 CFR 21 (NRC), used in or with any nuclear installation or activity; or (2) in medical applications or used on humans. Should any Product(s) be used in or with any nuclear installation or activity, medical application, used on humans, or misused in any way, OMEGA assumes no responsibility as set forth in our basic WARRANTY/DISCLAIMER language, and, additionally, purchaser will indemnify OMEGA and hold OMEGA harmless from any liability or damage whatsoever arising out of the use of the Product(s) in such a manner.

RETURN REQUESTS/INQUIRIES

Direct all warranty and repair requests/inquiries to the OMEGA Customer Service Department. BEFORE RETURNING ANY PRODUCT(S) TO OMEGA, PURCHASER MUST OBTAIN AN AUTHORIZED RETURN (AR) NUMBER FROM OMEGA'S CUSTOMER SERVICE DEPARTMENT (IN ORDER TO AVOID PROCESSING DELAYS). The assigned AR number should then be marked on the outside of the return package and on any correspondence.

The purchaser is responsible for shipping charges, freight, insurance and proper packaging to prevent breakage in transit.

FOR **WARRANTY** RETURNS, please have the following information available BEFORE contacting OMEGA:

1. Purchase Order number under which the product was PURCHASED,
2. Model and serial number of the product under warranty, and
3. Repair instructions and/or specific problems relative to the product.

FOR **NON-WARRANTY** REPAIRS, consult OMEGA for current repair charges. Have the following information available BEFORE contacting OMEGA:

1. Purchase Order number to cover the COST of the repair,
2. Model and serial number of the product, and
3. Repair instructions and/or specific problems relative to the product.

OMEGA's policy is to make running changes, not model changes, whenever an improvement is possible. This affords our customers the latest in technology and engineering.

OMEGA is a registered trademark of OMEGA ENGINEERING, INC.

© Copyright 2011 OMEGA ENGINEERING, INC. All rights reserved. This document may not be copied, photocopied, reproduced, translated, or reduced to any electronic medium or machine-readable form, in whole or in part, without the prior written consent of OMEGA ENGINEERING, INC.

Where Do I Find Everything I Need for Process Measurement and Control? **OMEGA...Of Course!** *Shop online at omega.comSM*

TEMPERATURE

- ☑ Thermocouple, RTD & Thermistor Probes, Connectors, Panels & Assemblies
- ☑ Wire: Thermocouple, RTD & Thermistor
- ☑ Calibrators & Ice Point References
- ☑ Recorders, Controllers & Process Monitors
- ☑ Infrared Pyrometers

PRESSURE, STRAIN AND FORCE

- ☑ Transducers & Strain Gages
- ☑ Load Cells & Pressure Gages
- ☑ Displacement Transducers
- ☑ Instrumentation & Accessories

FLOW/LEVEL

- ☑ Rotameters, Gas Mass Flowmeters & Flow Computers
- ☑ Air Velocity Indicators
- ☑ Turbine/Paddlewheel Systems
- ☑ Totalizers & Batch Controllers

pH/CONDUCTIVITY

- ☑ pH Electrodes, Testers & Accessories
- ☑ Benchtop/Laboratory Meters
- ☑ Controllers, Calibrators, Simulators & Pumps
- ☑ Industrial pH & Conductivity Equipment

DATA ACQUISITION

- ☑ Data Acquisition & Engineering Software
- ☑ Communications-Based Acquisition Systems
- ☑ Plug-in Cards for Apple, IBM & Compatibles
- ☑ Data Logging Systems
- ☑ Recorders, Printers & Plotters

HEATERS

- ☑ Heating Cable
- ☑ Cartridge & Strip Heaters
- ☑ Immersion & Band Heaters
- ☑ Flexible Heaters
- ☑ Laboratory Heaters

ENVIRONMENTAL MONITORING AND CONTROL

- ☑ Metering & Control Instrumentation
- ☑ Refractometers
- ☑ Pumps & Tubing
- ☑ Air, Soil & Water Monitors
- ☑ Industrial Water & Wastewater Treatment
- ☑ pH, Conductivity & Dissolved Oxygen Instruments