

GETTING STARTED



CHAPTER 1

In This Chapter:

Introduction	1-2
Conventions Used	1-3
DL05 Micro PLC Components	1-4
Programming Methods	1-4
I/O Selection Quick Chart	1-5
Quick Start for PLC Checkout and Programming	1-6
Steps to Designing a Successful System	1-10
Questions and Answers about DL05 Micro PLCs	1-12

1 Introduction

The Purpose of this Manual

Thank you for purchasing a DL05 Micro PLC. This manual shows you how to install, program, and maintain all the Micro PLCs in the DL05 family. It also helps you understand how to interface them to other devices in a control system. This manual contains important information for personnel who will install DL05 PLCs, and for the PLC programmer. If you understand PLC systems our manuals will provide all the information you need to get and keep your system up and running.

Where to Begin

If you already understand the DL05 Micro PLC please read Chapter 2, “Installation, Wiring, and Specifications”, and proceed on to other chapters as needed. Be sure to keep this manual handy for reference when you run into questions. If you are a new DL05 customer, we suggest you read this manual completely so you can understand the wide variety of features in the DL05 family of products. We believe you will be pleasantly surprised with how much you can accomplish with **AutomationDirect** products.

Supplemental Manuals

The *DO-OPTIONS-M* manual will be most helpful to select and use any of the optional modules that are available for the DL05 PLC which includes the analog I/O modules. If you have purchased operator interfaces or *DirectSOFT* programming software you will need to supplement this manual with the manuals that are written for these products.

Technical Support

We realize that even though we strive to be the best, we may have arranged our information in such a way you cannot find what you are looking for. First, check these resources for help in locating the information:

- **Table of Contents** – chapter and section listing of contents, in the front of this manual
- **Appendices** – reference material for key topics, near the end of this manual

You can also check our online resources for the latest product support information:

- **Internet** – the address of our website is: <http://www.automationdirect.com>

If you still need assistance, please call us at 770-844-4200. Our technical support team will be available to work with you in answering your questions. They are available Monday through Friday from 9:00 A.M. to 6:00 P.M. Eastern Standard Time.

Conventions Used



When you see the “notepad” icon in the left-hand margin, the paragraph to its immediate right will be a **special note**. Notes represent information that may make your work quicker or more efficient. The word **NOTE:** in boldface will mark the beginning of the text.



When you see the “exclamation point” icon in the left-hand margin, the paragraph to its immediate right will be a **warning**. This information could prevent injury, loss of property, or even death in extreme cases. Any warning in this manual should be regarded as critical information that should be read in its entirety. The word **WARNING** in boldface will mark the beginning of the text.

Key Topics for Each Chapter

The beginning of each chapter will list the key topics that can be found in that chapter.

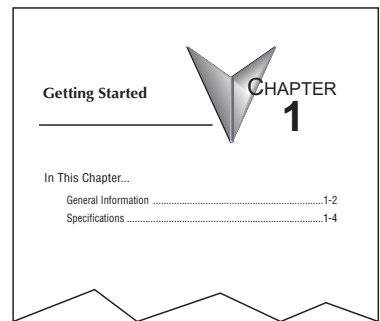

1 DL05 Micro PLC Components

The DL05 Micro PLC family is a versatile product line that provides a wide variety of features in a very compact footprint. The PLCs are small, yet offer many features usually found only in larger, more expensive systems. These include a removable connector, and two RS-232C communication ports.

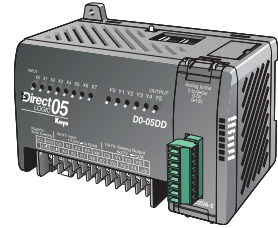

The DL05 Micro PLC Family

The DL05 Micro PLC family includes eight different versions. All have the same appearance and CPU performance. The CPU offers the same instruction set as our popular DL240 CPU, plus several more instructions specifically designed for machine control applications. All DL05 PLCs have two RS-232C communications ports. Units with DC inputs have selectable high-speed input features on three input points. Units with DC outputs offer selectable pulse output capability on the first and second output points. All DL05 Micro PLCs offer a large amount of program memory, a substantial instruction set and advanced diagnostics. Details of these features and more are covered in Chapter 3, CPU Specifications and Operation. The eight types of DL05 Micro PLCs provide a variety of Input/Output choices, listed in the following table.

DL05 Micro PLC Family					
DL05 Part Number	Discrete Input Type	Discrete Output Type	External Power	High-Speed Input	Pulse Output
DO-05AR	AC	Relay	95-240 VAC	No	No
DO-05DR	DC	Relay	95-240 VAC	Yes	No
DO-05AD	AC	DC	95-240 VAC	No	Yes
DO-05DD	DC	DC	95-240 VAC	Yes	Yes
DO-05AA	AC	AC	95-240 VAC	No	No
DO-05DA	DC	AC	95-240 VAC	Yes	No
DO-05DR-D	DC	Relay	12-24 VDC	Yes	No
DO-05DD-D	DC	DC	12-24 VDC	Yes	Yes

DirectSOFT 5 Programming for Windows™

The DL05 Micro PLC can be programmed with one of the most advanced programming packages in the industry — *DirectSOFT 5*, a Windows-based software package that supports familiar features such as cut-and-paste between applications, point-and-click editing, viewing and editing multiple application programs at the same time, etc.

DirectSOFT 5 universally supports the *DirectLOGIC* CPU families. This means you can use the full version of *DirectSOFT 5* to program DL05, DL06, DL105, DL205, DL305, DL405 CPUs. The *DirectSOFT 5* Programming Software User Manual discusses the programming language in depth. *DirectSOFT* version 2.4 or later is needed to program the DL05.

Handheld Programmer

All DL05 Micro PLCs have built-in programming ports for use with the handheld programmer (D2–HPP), the same programmer used with the DL06, DL105 and DL205 families. The handheld programmer can be used to create, modify and debug your application program. A separate manual discusses the Handheld Programmer. Only D2–HPPs with firmware version 1.09 or later will program the DL05.



NOTE: Not all program instructions are available to use with the HHP, such as the DRUM instruction. Use *DirectSOFT 5* for these instructions.

I/O Selection Quick Chart

The eight versions of the DL05 have Input/Output circuits which can interface to a wide variety of field devices. In several instances a particular Input or Output circuit can interface to either DC or AC voltages, or both sinking and sourcing circuit arrangements. Check this chart carefully to find the proper DL05 Micro PLC to interface to the field devices in your application.

I/O Selection Chart						
DL05 Part Number	INPUTS			OUTPUTS		
	I/O type/commons	Sink/Source	Voltage Ranges	I/O type/commons	Sink/Source	Voltage/ Current Ratings
D0–05AR	AC / 2	–	90 – 120 VAC	Relay / 2	Sink or Source	6 – 27VDC, 2A* 6 – 240 VAC, 2A *
D0–05DR	DC / 2	Sink or Source	12 – 24 VDC	Relay / 2	Sink or Source	6 – 27VDC, 2A* 6 – 240 VAC, 2A *
D0–05AD	AC / 2	–	90 – 120 VAC	DC / 1	Sink	6 – 27 VDC, 0.5A (Y0–Y2) 6 – 27 VDC, 1.0A (Y3–Y5)
D0–05DD	DC / 2	Sink or Source	12 – 24 VDC	DC / 1	Sink	6 – 27 VDC, 0.5A (Y0–Y2) 6 – 27 VDC, 1.0A (Y3–Y5)
D0–05AA	AC / 2	–	90 – 120 VAC	AC / 2	–	17 – 240 VAC, 47 – 63 Hz, 0.5A*
D0–05DA	DC / 2	Sink or Source	12 – 24 VDC	AC / 2	–	17 – 240 VAC, 47 – 63 Hz, 0.5A *
D0–05DR–D	DC / 2	Sink or Source	12 – 24 VDC	Relay / 2	Sink or Source	6 – 27 VDC, 2A 6 – 240 VAC, 2A *
D0–05DD–D	DC / 2	Sink or Source	12 – 24 VDC	DC / 1	Sink	6 – 27 VDC, 0.5A (Y0–Y2) 6 – 27 VDC, 1.0A (Y3–Y5)

* See Chapter 2 Specifications for your particular DL05 version.

1 Quick Start for PLC Checkout and Programming

This example is not intended to tell you everything you need to start-up your system, warnings and helpful tips are in the rest of the manual. It is only intended to give you a general picture of what you will need to do to get your system powered-up.

Step 1: Unpack the DL05 Equipment

Unpack the DL05 and gather the parts necessary to build this demonstration system. The recommended components are:

- DL05 Micro PLC
- AC power cord or DC power supply
- Toggle switches or simulator module, F0-08SIM(see Step 2 on next page).
- Hook-up wire, 16-22 AWG
- DL05 User Manual (this manual)
- A small screwdriver, 5/8" flat or #1 Philips type

You will need at least one of the following programming options:

- *DirectSOFT 5* Programming Software, *DirectSOFT 5* Manual, and a programming cable (connects the DL05 to a personal computer), or
- D2-HPP Handheld Programmer (comes with programming cable), and the Handheld Programmer Manual

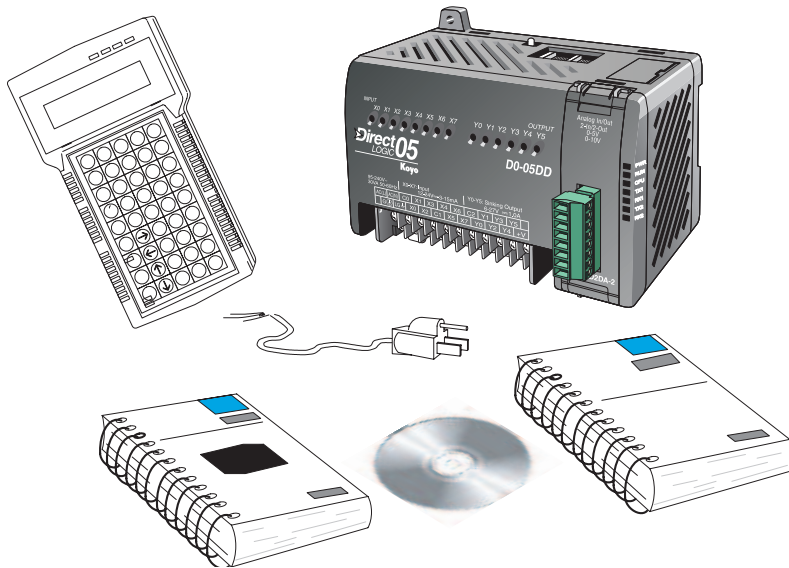

Step 2: Connect Switches to Input Terminals

To finish this quick-start exercise or study other examples in this manual, you'll need to either connect some input switches as shown below or install the F0-08SIM, simulator module, which needs no wiring, into the option slot. If you have DC inputs you will need to use the FA-24PS (24VDC) or another external 12-24VDC power supply. Be sure to follow the instructions in the accompanying *WARNING* note.

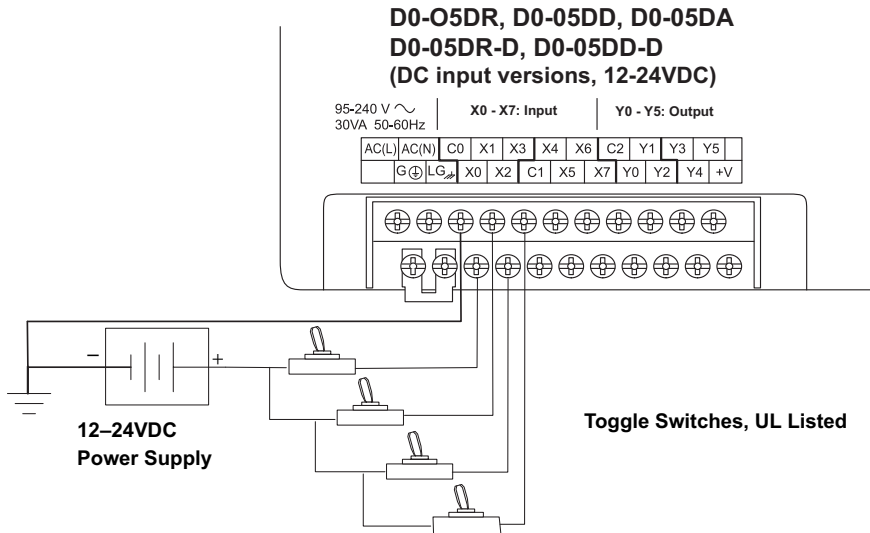

D0-05AR, D0-05AD, D0-05AA (AC input versions, 120V AC only)

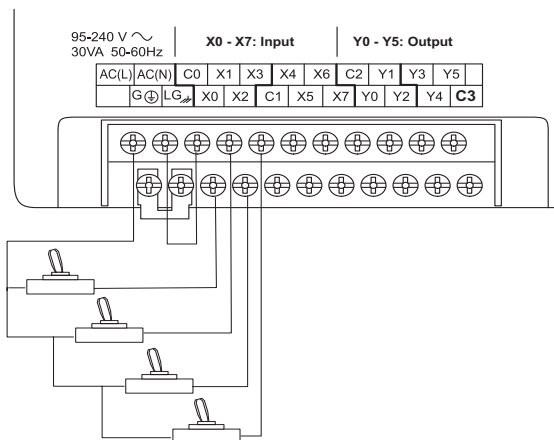

WARNING: DO NOT wire the toggle switches as shown to 240VAC-powered units. The discrete inputs will only accept 120VAC nominal. Also, remove power and unplug the DL05 when wiring the switches. Only use UL-approved switches rated for at least 250VAC, 1A for AC inputs. Firmly mount the switches before using.

Step 3: Connect the Power Wiring

Connect the power input wiring for the DL05. Observe all precautions stated earlier in this manual. For more details on wiring, see Chapter 2 on Installation, Wiring, and Specifications. When the wiring is complete, close the connector covers. Do not apply power at this time.

110/220 VAC Power Input

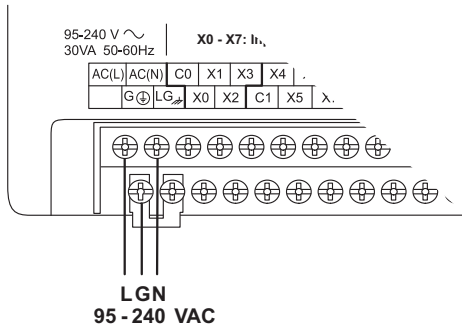

12/24 VDC Power Input

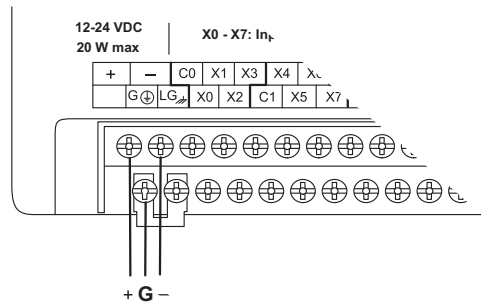

Step 4: Connect the Programming Device

Most programmers will use *DirectSOFT 5* programming software, installed on a personal computer. Or, you may need the portability of the Handheld Programmer. Both devices will connect to COM port 1 of the DL05 via the appropriate cable.

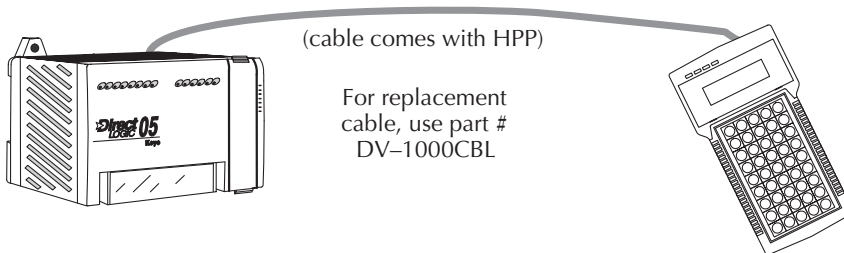
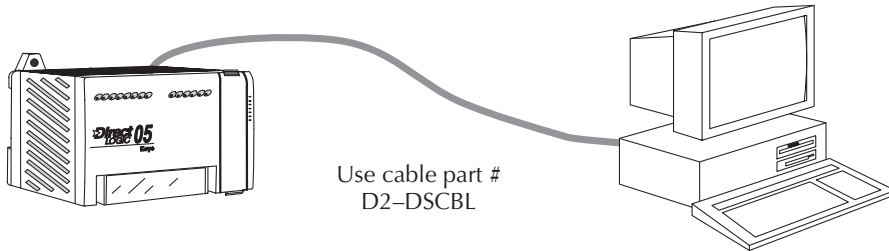

Step 5: Switch on the System Power

Apply power to the system and ensure the PWR indicator on the DL05 is on. If not, remove power from the system and check all wiring and refer to the troubleshooting section in Chapter 9 for assistance.

Step 6: Initialize Scratchpad Memory

It's a good precaution to always clear the system memory (scratchpad memory) on a new DL05. There are two ways to clear the system memory:

- In *DirectSOFT 5*, select the PLC menu, then Setup, then Initialize Scratchpad. For additional information, see the *DirectSOFT 5 Manual*.
- For the Handheld Programmer, use the AUX key and execute AUX 54.

See the Handheld Programmer Manual for additional information.

Step 7: Enter a Ladder Program

At this point, *DirectSOFT 5* programmers need to refer to the Quick Start Tutorial in the *DirectSOFT 5 Manual*. There you will learn how to establish a communications link with the DL05 PLC, change CPU modes to Run or Program, and enter a program. If you are learning how to program with the Handheld Programmer, make sure the CPU is in Program Mode (the RUN LED on the front of the DL05 should be off). If the RUN LED is on, use the MODE key on the Handheld Programmer to put the PLC in Program Mode. Enter the following keystrokes on the Handheld Programmer.

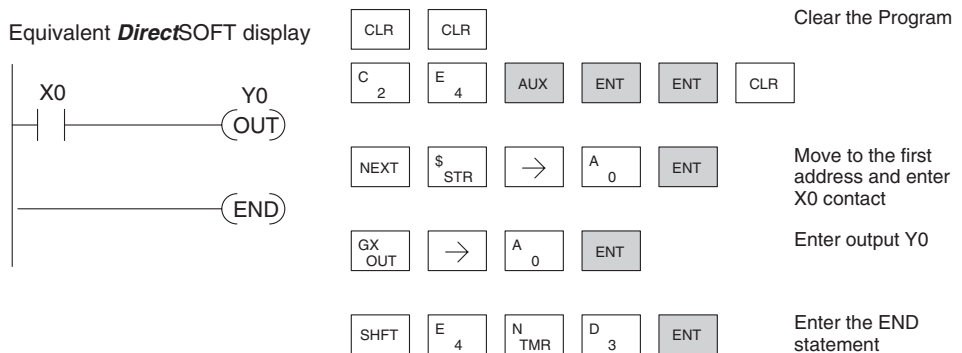

After entering the simple example program put the PLC in Run mode by using the Mode key on the Handheld Programmer.

The RUN indicator on the PLC will illuminate indicating the CPU has entered the Run mode. If not, repeat this step, ensuring the program is entered properly or refer to the troubleshooting guide in chapter 9.

After the CPU enters the run mode, the output status indicator for Y0 should follow the switch status on input channel X0. When the switch is on, the output will be on.

1 Steps to Designing a Successful System

Step 1: Review the Installation Guidelines

Always make safety the first priority in any system design. Chapter 2 provides several guidelines that will help you design a safer, more reliable system. This chapter also includes DL wiring guidelines for the various versions of the DL05 PLC.

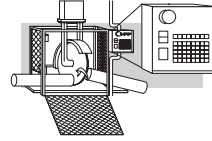

Step 2: Understand the PLC Setup Procedures

The PLC is the heart of your automation system. Make sure you take time to understand the various features and setup requirements.

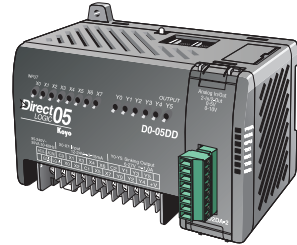

Step 3: Review the I/O Selection Criteria

There are many considerations involved when you select your I/O type and field devices. Take time to understand how the various types of sensors and loads can affect your choice of I/O type.

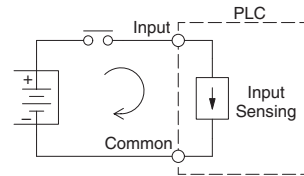

Step 4: Choose a System Wiring Strategy

It is important to understand the various system design options that are available before wiring field devices and field-side power supplies to the Micro PLC.

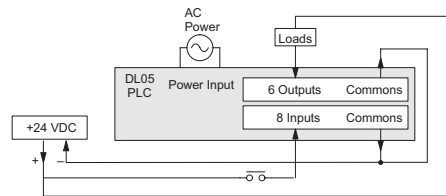

Step 5: Understand the System Operation

Before you begin to enter a program, it is very helpful to understand how the DL05 system processes information. This involves not only program execution steps, but also involves the various modes of operation and memory layout characteristics.

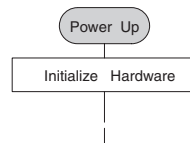

Step 6: Review the Programming Concepts

The DL05 PLC instruction set provides for three main approaches to solving the application program, depicted in the figure below.

- RLL diagram-style programming is the best tool for solving boolean logic and general CPU register/accumulator manipulation. It includes dozens of instructions, which will also be needed to augment drums and stages.
- The Timer/Event Drum Sequencer features up to 16 steps and offers both time and/or event-based step transitions. The DRUM instruction is best for a repetitive process based on a single series of steps.
- Stage programming (also called RLL^{PLUS}) is based on state-transition diagrams. Stages divide the ladder program into sections which correspond to the states in a flow chart you draw for your process.

Standard RLL Programming
(see Chapter 5)

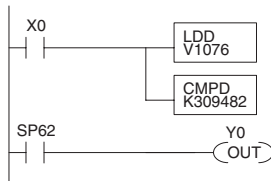

Timer/Event Drum Sequencer
(see Chapter 6)

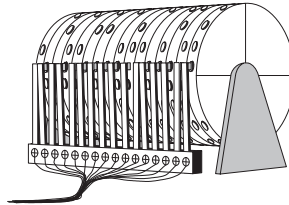

Stage Programming
(see Chapter 7)

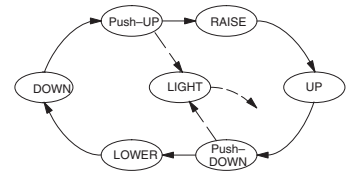

After reviewing the programming concepts above, you'll be equipped with a variety of tools to write your application program.

Step 7: Choose the Instructions

Once you have installed the Micro PLC and understand the main programming concepts, you can begin writing your application program. At that time you will begin to use one of the most powerful instruction sets available in a small PLC.

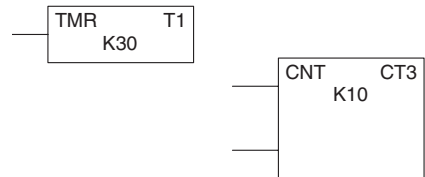

Step 8: Understand the Maintenance and Troubleshooting Procedures

Sometimes equipment failures occur when we least expect it. Switches fail, loads short and need to be replaced, etc. In most cases, the majority of the troubleshooting and maintenance time is spent trying to locate the problem. The DL05 Micro PLC has many built-in features such as error codes that can help you quickly identify problems.

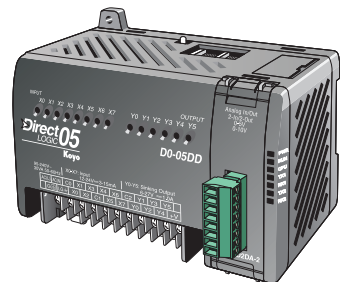

Questions and Answers about DL05 Micro PLCs

Q. What is the instruction set like?

A. The instruction set is very close to our popular DL240 CPU. However, there are significant additions, such as the drum instruction, networking, PID control and High-Speed I/O capabilities.

Q. Do I have to buy the full *DirectSOFT 5* programming package to program the DL05?

A. No, *DirectSOFT 5* programming software is available for programming *DirectLOGIC* PLCs for no additional charge; however, it will only allow 100 maximum words to be programmed. Go to AutomationDirect.com for more information.

Q. Is the DL05 expandable?

A. No, the DL05 series are stand-alone PLCs with one slot for the installation of an available option module. They do not have expansion bases, such as our DL205 system which has expansion bases, yet are very compact and affordable.

Q. Does the DL05 have motion control capability?

A. Yes. The units with DC I/O have selectable high-speed input features on three inputs. There is also an optional High-Speed Counter I/O module available with special utility software. Either can accept pulse-type input signals for high-speed counting or timing applications and provide high-speed pulse-type output signals for stepper/servo motor control, monitoring, alarm or other discrete control functions. Three types of motion profiles are available, which are explained in Chapter 3.

Q. Are the ladder programs stored in a removable EEPROM?

A. The DL05 contains a non-removable FLASH memory for program storage, which may be written and erased thousands of times. You may transfer programs to/from the DL05 using *DirectSOFT 5* on a PC, or the HPP (which does support a removable EEPROM). There is an optional CMOS RAM memory cartridge (MC) available (See Chapter 10).

Q. Does the DL05 contain fuses for its outputs?

A. There are no output circuit fuses. Therefore, we recommend fusing each channel, or fusing each common. See Chapter 2 for I/O wiring guidelines.

Q. Is the DL05 Micro PLC U.L. approved?

A. The Micro PLC has met the requirements of UL (Underwriters' Laboratories, Inc.), and CUL (Canadian Underwriters' Laboratories, Inc.).

Q. Does the DL05 Micro PLC comply with European Union (EU) Directives?

A. The Micro PLC has met the requirements of the European Union Directives (CE).

Q. Which devices can I connect to the communication ports of the DL05?

A. Port 1: The port is RS-232C, fixed at 9600 baud, and uses the proprietary K-sequence protocol. The DL05 can also connect to Modbus RTU and *DirectNET* networks as a slave device through port 1. The port communicates with the following devices:

- DV-1000 Data Access Unit or Optimization Operator interface panels
- *DirectSOFT 5* (running on a personal computer)
- D2-HPP handheld programmer
- Other devices which communicate via K-sequence protocol should work with the DL05 Micro PLC. Contact the vendor for details.

A. Port 2: The port is RS-232C, with selective baud rates (300-38,400bps), address and parity. It also supports the proprietary K-sequence protocol as well as *DirectNET* and Modbus RTU and non-sequence/print protocols.

Q. Can the DL05 accept 5VDC inputs?

A. No, 5 volts is lower than the DC input ON threshold. However, many TTL logic circuits can drive the inputs if they are wired as open collector (sinking) inputs. See Chapter 2 for I/O wiring guidelines.