

# VISION

# metron 81

USER'S MANUAL  
AND INSTRUCTIONS



[VISIONTECHUSA.COM](http://VISIONTECHUSA.COM)





Installation Instruction

Instrucciones de Instalación

Instructions de Montage

Istruzioni di Montaggio

Montageanleitung

安裝

取り付け方法説明

En

Sp

Fr

It

De

Ch

Ja



## User's Manual and Instructions

Installation instructions	02
Warranty	02
Wheels package	05
Wheelset installation	06
Wheel Preload Hub Adjustment	07
Technical specifications	09
Spoke replacement and lacing	10
Maintenance recommendations	12
Wheel replacement parts	14

## INSTALLATION INSTRUCTIONS

Congratulations on your Vision product. Please read these instructions and follow them for correct use. Failure to follow the warnings and instructions could result in damage to product which is not covered under warranty, damage to bicycle or cause an accident resulting in injury or death. Since specific tools and experience are necessary for proper installation, it is recommended that the product be installed by a qualified bicycle technician.

## WARRANTY

Full Speed Ahead (FSA) warrants all FSA, Gravity, Vision, Metropolis and RPM products to be free from defects in materials or workmanship for a period of two years after original purchase unless otherwise stated in the full warranty policy. The warranty is non-transferable and valid to the original purchaser of the product only. Full warranty policy is available at:

**FULLSPEEDAHEAD.COM**

**⚠ WARNING**

Regularly check the wheels to be certain they are fastened securely to the bicycle fork. If the Quick Release is not installed correctly, the wheel may become separated from the fork and result in an accident, personal injury or death.

**⚠ WARNING**

Tires mounted on clincher wheels should not be inflated above 125 psi. (8.5 bar). Tires mounted on tubular wheels should be inflated per tire manufacturer recommendations.

**⚠ WARNING**

Carbon fiber rims require special brake pads to guarantee proper braking performance. Use only Vision brake pads with Vision wheels. Using other brands of brake pads can damage the rim and cause an accident, personal injury or death. Using other brands of brake pads will void the Vision Warranty.

**⚠ WARNING**

Inspect the brake pads frequently for metal chips or other foreign debris. Metal debris and foreign objects in the brake pad will cause compromised braking performance and severe rim damage that may result in wheel failure and cause accident.

**⚠ WARNING**

Rims wear with use. Check the braking surface of rim frequently and replace if worn. Riding with a worn rim may cause wheel failure and serious accident resulting in injury.

## METRON 81 (VT-880 / VT-880CH)

PRODUCT	ITEM CODE
VISION METRON 81 Tubular VT-880 Wheelset Shimano Red Decal	710-0159
VISION METRON 81 Clincher VT-880CH Wheelset Shimano Red Decal	710-0158CH
VISION METRON 81 Tubular VT-880 Wheelset Shimano Grey Black Decal	710-0159BKG
VISION METRON 81 Clincher VT-880CH Wheelset Shimano Grey Black Decal	710-0158CHBKG
VISION METRON 81 Tubular VT-880 Wheelset Campagnolo Red Decal	710-0118
VISION METRON 81 Clincher VT-880CH Wheelset Campagnolo Red Decal	710-00020152031
VISION METRON 81 Tubular VT-880 Wheelset Campagnolo Grey Black Decal	710-0118GS
VISION METRON 81 Clincher VT-880CH Wheelset Campagnolo Grey Black Decal	710-00020152030
VISION METRON 81 Tubular VT-880 Front Wheel Red Decal	710-0347CH
VISION METRON 81 Clincher VT-880CH Front Wheel Red Decal	710-0347BKG
VISION METRON 81 Tubular VT-880 Front Wheel Grey Black Decal	710-00020152030
VISION METRON 81 Clincher VT-880CH Front Wheel Grey Black Decal	710-0347CHBKG
VISION METRON 81 Tubular VT-880 Rear Wheel Shimano Red Decal	710-0348
VISION METRON 81 Clincher VT-880CH Rear Wheel Shimano Red Decal	710-0348CH
VISION METRON 81 Tubular VT-880 Rear wheel Shimano Grey Black Decal	710-0348BKG
VISION METRON 81 Clincher VT-880CH Rear wheel Shimano Grey Black Decal	710-0348CHBKG
VISION METRON 81 Tubular VT-880 Rear wheel Campagnolo Red Decal	710-0349
VISION METRON 81 Clincher VT-880CH Rear wheel Campagnolo Red Decal	710-0349CH
VISION METRON 81 Tubular VT-880 Rear wheel Campagnolo Grey Black Decal	710-0349BKG
VISION METRON 81 Clincher VT-880CH Rear wheel Campagnolo Grey Black Decal	710-0349CHBKG



## WHEELS PACKAGE

- A. Wheels
- B. Wheels bag
- C. Accessories bag + Instructions
- D. Quick Release (QR)
- E. Brake Pads
- F. Valve Extensions (only VT-880)
- G. Spoke Protector

**⚠ WARNING** Vision Spoke Protector is intended to prevent the chain from falling down in the spokes. Please install it on the rear wheel before riding.

En

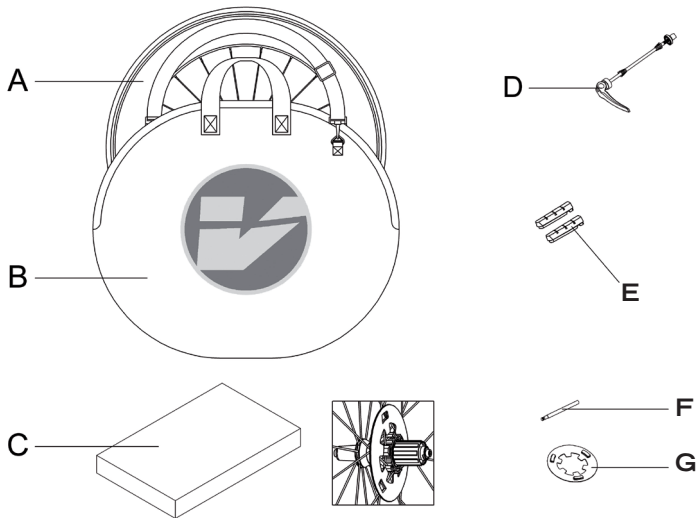

## WHEELSET INSTALLATION

1. For mounting tires, carefully follow the instructions provided by the tire manufacturer.

2. Apply light grease onto the Freehub Body. Install the cassette per manufacturer's recommendations. The Shimano freehub body is compatible with S11 cassette. A spacer (A) is required when mounting S9 & S10 cassette. The Campagnolo Freehub Body is compatible with C10 and C11 cassettes.

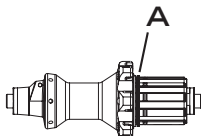

### ⚠ WARNING

Do not use Vision carbon specific pads with non carbon (alloy) rims.

3. Insert the Quick Releases into the wheel. The lever of the Quick Releases should go on the non-drive side. Thread the Quick Release nut, but do not tight.

**Note:** Front Quick Release is shorter than rear.

4. Install the Front and Rear Wheel into the drop-outs of the fork and frame. With the QR lever in the open position, tighten the QR until it is in contact with the frame or fork dropouts. Close the QR lever. The QR lever should require substantial effort to close the last 25-30 degrees. If it closes with only moderate hand pressure, the QR must be readjusted by opening the QR lever, then turning the QR nut clockwise until the closing action of the QR lever requires the recommended force.

### ⚠ WARNING

• If you are unfamiliar with Quick Release assembly it is recommended to ask for advice from your local bike shop. Riding with an improperly assembled Quick Release can cause the wheel to shift while in use resulting in accident and injury.

- Regularly check the QR adjustment. If the Quick Release is not installed correctly, the wheel may become separated from the fork and result in an accident, personal injury or death.
- Always close the skewer lever completely. Do not allow a frame or fork tube or any other member to inhibit full lever travel when closing. Failure to close the lever completely will limit cam engagement and the skewer's ability to hold the wheel in place.

**Note:** The QR must be periodically lubricated at the pivot points so it can exert maximum sideways force.



OK

OK

OK

NO!

# WHEEL PRELOAD HUB ADJUSTMENT

## Specification

Model Name Vision PRA Hubs

Model No. VT-880 VT-880CH PRA Hubs

### Front Hub ASM:

- |                    |                            |
|--------------------|----------------------------|
| 1. Front Hub Shell | 4. Threaded Preload Collar |
| 2. Front Hub Axle  | 5. M3 Pinch Bolt           |
| 3. Axle End Cap    | 6. Alignment Collar        |

### Front Hub Adjustment

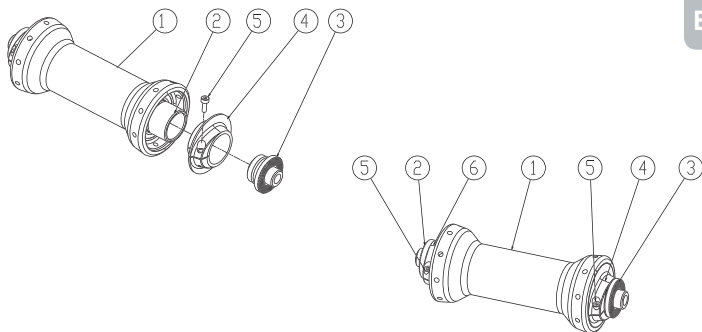

1. Unscrew the Pinch Bolt (5) in the Threaded Preload Collar (4) using a 2.5mm Allen Key.
2. Tighten the Threaded Preload Collar (4) by-hand until it stops, then back-off (loosen) by 1/8th turn.
3. Screw in the Pinch Bolt (5) and tighten with the Allen Key to 2Nm.
4. Install the wheel in the bike and ensure that there is no lateral (side-to-side) movement and that the wheel rotates freely.

**Rear Hub ASM:**

7. Rear Hub Shell

8. Axle End Nut

9. Threaded Preload Collar

10. Rear Axle

11. Freehub Preload Nut

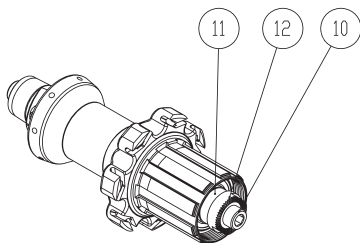
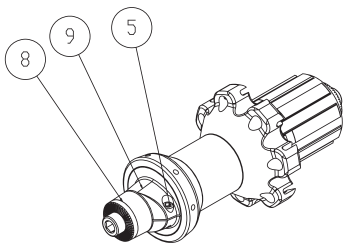

1. Unscrew the Pinch Bolt (5) in the Threaded Preload Collar (9) using a 2.5mm Allen Key.

2. Screw in Pinch Bolt (5) and tighten with Allen Key to 3Nm.

3. Install the wheel in the bike and ensure that there is no lateral (side-to-side) movement and that the wheel rotates freely.

## TECHNICAL SPECIFICATIONS

<b>Wheel Description</b>	Vision Metron 81
<b>Model number</b>	VT-880 / VT-880CH
<b>Rim size</b>	633x24 / 700x16C
<b>Rim width / height</b>	24mm x 81mm / 25mm x 81mm
<b>Tire type</b>	Tubular / Clincher
<b>Spokes Lengths / Number x Pattern</b>	Front 233 / 18x0 radial Rear Left 233 mm / 7x0 radial Rear Right 235 mm /14x2
<b>Spokes Gauge / End</b>	AE-14 / Direct Pull
<b>Nipples</b>	15mm ABS Alloy, external

**⚠ WARNING** Use original Vision spare parts only for your service. Use of incorrect spoke types and lengths may cause failure of the wheel resulting in accident and person injury.

## WHEEL TRUING

**⚠ CAUTION** Bicycle wheels are straight, round, and stable because of a balance of spoke tension. The rim's shape can be changed by tightening and loosening spoke's nipples. Wheel truing should be performed by persons with adequate wheel truing experience or training. If you do not have confidence or experience with wheel truing, take the wheels to a qualified technician for service.

## SPOKE REPLACEMENT AND LACING

### ⚠ CAUTION

Before replacing a spoke, please check the above technical specifications for the correct spoke length and type. Always use original Vision spare parts before proceeding with the replacement.

1. Remove the spoke and nipple to be replaced
2. **Front hub:** unscrew the axle end cap (3) using a 5mm Allen wrench and the Threaded Preload Collar (4) using a 2.5mm Allen wrench; and remove the axle end cap by hand (Fig.1)
3. Remove the Threaded Preload Collar (4) and the front axle (2)
4. Slide the new spoke in the flange hub hole and re-mount the hub internals following the sequence shown in Fig.1
5. **Rear hub - non drive side:** unscrew the Pinch Bolt (5) in the Threaded Preload Collar (9) using a 2.5 mm Allen Key (Fig.2) and then unscrew the Threaded Preload Collar (9)
6. Using a 5mm Allen wrench unscrew and remove the rear Axle End Nut (8) together with Threaded Preload Collar (9)
7. Slide the new spoke in the flange hub hole and re-mount the hub internals following the sequence shown in Fig.2
8. **Rear hub - drive side:** replace the spoke in accordance with the original position and install it with proper positioning to adjacent spokes.
9. Secure the spoke to the rim by tightening the nipple
10. Use a spoke tension measuring device to follow the recommended tension as in the chart below
11. After replacing the spoke, tensioned and centered the wheel, check that the flat spoke (aero) is oriented in an aerodynamic position.

### ⚠ WARNING

Maximum spoke tension must not exceed the tension specification (see chart below). Using tension above max recommended tension will void warranty and cause wheel failure resulting in serious accidents and injury. If tension above maximum is necessary to true the wheel, the rim may be damaged and should be replaced.

Always avoid the rotation of the spoke (spoke wind-up) when the nipple is tightened or loosened by using an anti-rotation spoke tool.

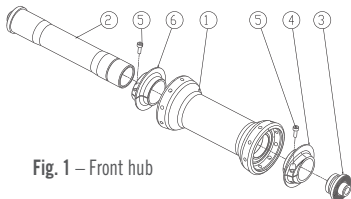

Fig. 1 – Front hub

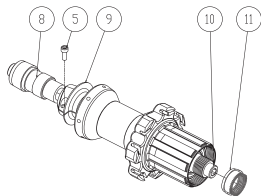
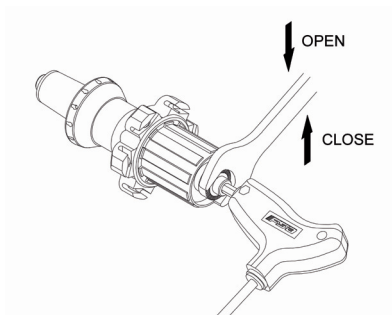

Fig. 2 – Rear hub

RECOMMENDED SPOKE TENSION		
Front Wheel	Rear Wheel	
Left&Right Side	Left Side	Right Side
90-110 Kgf	80-100 Kgf	100-120 Kgf

## REPLACEMENT OF THE FREEHUB BODY

1. Unscrew the fixing nut by turning it clockwise with a 17 mm wrench while holding the axle steady with by a 5 mm Allen key.
2. Remove the freehub body from the axle carefully to avoid damaging the spring or ratchet pawls.
3. Insert the new freehub body on the axle and turn the body till the all ratchet pawls are in line with the pawl seats in the hub, and then fully insert the freehub body.
4. If necessary, add low-friction grease to preserve the freehub body mechanism.
5. Holding the axle steady by 5 mm Allen key, tighten the fixing nut with a 17mm wrench to an approximate torque of 8 Nm.
6. It is recommended to apply a thin layer of medium strength thread locker on the axle then tighten the fixing nut that hold the freehub body.



**NOTE:** Vision Wheels can be changed from Shimano to Campagnolo compatible (and vice versa) by replacing the freehub body.

## WHEEL MAINTENANCE RECOMMENDATIONS

It is the user's responsibility to examine the product on a regular basis to determine the need for service or replacement. Cyclists should inspect their bicycle and parts on a regular basis in order to detect damage that may have occurred from normal use or for missing parts. Check all parts for damage and wear before every use. Should any problems or concerns arise, discontinue riding the bicycle and have it inspected by a qualified bicycle technician.

### **⚠ WARNING**

Using wheels that have not been installed or centered correctly, present broken, damaged, or has missing parts may fail or cause rider to lose control of bicycle leading to accident, resulting in personal injury or death.

## HUB MAINTENANCE

Vision hubs are equipped with high grade, precision, sealed cartridge bearings. Due to varying factors it is important to have the hub bearings inspected and maintained periodically. The recommended service intervals are:

- Inspection after each riding season, one calendar year, or 8,000 to 10,000 Km, whichever comes first.
- After use in rain, storm, muddy, and wet conditions
- Anytime rotational smoothness, signs of corrosion, damage to rubber seals and bearing covers is apparent.

### **Tech Tips:**

- Avoid getting solvents, aerosol lubricants (as for chain), and strong cleaning solutions on the hubs. The solvent can wick passed the seals and break down the bearing grease.
- When washing the bike, use only mild soap and a gentle stream of water for rinsing. Always avoid pressure washing. Such systems can direct super heated water with special wetting agents at 10X atmospheric pressure, forcing water passed the bearing seal and removing vital bearing grease.

### **⚠ CAUTION**

Since specific tools and experience are necessary for hub maintenance, it is recommended that the service should be done by a Vision Authorized Service Center.

Please contact the Authorized Vision Distributors and Warranty Service Centers closest to your country of residence. A list of Authorized is posted at [VISIONTECHUSA.COM](http://VISIONTECHUSA.COM).



## RIM MAINTENANCE

-When braking, especially during descents, use both front and rear brakes. Front and Rear brakes have different benefits and limitations, so use them according to instructions from an experienced rider. It is important that both rims are employed during descents to properly dissipate heat.

-When riding in wet or dirty conditions, listen for scraping sounds that might indicate soil or grit is trapped in the brake pad. If so, the pad will be less effective for stopping and extra abrasive against the rim. Stop, remove the wheel and inspect the pad surface. Remove any debris before it damages the rim brake surface.

-Water on the rim and brake pads will reduce brake effectiveness. In the wet, allow extra distance for stopping.

-Vigorous braking will cause brake pads to melt and mark the rim brake track. Do not allow melted pad material to accumulate on the rim surface. Pad deposits should be removed with care using a slightly abrasive pad and alcohol. Be careful to keep solvents from reaching the tire or the rim cement that securing the tire. Pad material on the rim brake track can interfere with brake response, cause vibration, and create hot spots that could damage the rim.

-If, during frequent inspections, noticeable impact damage or any other deformation of the rim is apparent, discontinue use and immediately seek advice from an experienced mechanic. If an experienced mechanic is unavailable, contact Vision directly at [VISIONTECHUSA.COM](http://VISIONTECHUSA.COM).

## TIRE GLUING

Before installing the tubular tire carefully read the instructions from the tire manufacturer. For proper glue bonding, clean the rim with acetone or denatured alcohol, and lightly scuff the gluing surface with 240-320 grit sandpaper.

To prevent damage to the tire and rim, do not use any tools to install or remove the tubular tire.

**⚠ WARNING** In the event of a bicycle accident, discontinue riding the bicycle until it has been thoroughly examined by a qualified bicycle mechanic, and any damaged parts replaced.

## WHEEL REPLACEMENT PARTS:

Replacement parts are available for purchase through all bicycle service and retail locations. If the bicycle shop does not stock the necessary parts, it can be ordered by the retail location from a VISION distributor or VISION directly. A list of distributors is available at [VISIONTECHUSA.COM](http://VISIONTECHUSA.COM).

## CONTACT

If you have questions, please visit our web site contact page at:  
[VISIONTECHUSA.COM](http://VISIONTECHUSA.COM).

**Notes:** Specifications of product may be changed or improved for performance. Please refer to website periodically for technical updates and revised instructions. Printed in Taiwan.