

JumpSport®



10ft x 17ft Safety Enclosure User's Manual

Assembly, Installation, Care, Maintenance, and Use
Instructions

WARNING

Read these materials prior to assembling and
using this Trampoline Enclosure



DO NOT attempt or allow somersaults. Landing on the head or neck can cause serious injury, paralysis or death, even when landing in the middle of the bed.



DO NOT allow more than one person inside the trampoline enclosure. Use by more than one person at the same time can result in serious injury.

Use trampoline only with mature, knowledgeable supervision.



DO NOT attempt to jump over the barrier.



DO NOT intentionally rebound off the barrier.

DO NOT hang from, kick, cut or climb on the barrier.

The maximum user weight is 230 pounds.

Retain address information for future use.

JumpSport, Inc.
2055 South 7th Street, Suite A
San Jose, CA 95112 U.S.A.

408-213-2551
www.jumpsport.com

Copyright Notice

This material is protected by United States copyright laws and is proprietary to JumpSport, Inc. Disclosure, reproduction, translation, modification, or use of this document by anyone other than authorized employees, authorized users, or licensees of JumpSport without the prior written consent of JumpSport, Inc. is prohibited.

The information in this document is subject to change without notice. JumpSport, Inc. shall not be liable for any damages resulting from technical errors or omissions, which may be present in this document, or from use of this document.

Copyright © 2005-2009, by JumpSport, Inc. All rights reserved.

Printed: 2009

Instruction Manual P/N: INS-P-10921B

JumpSport 10ft x 17ft Safety Enclosure P/N: SEJ-S-11345A

JumpSport 10ft x 17ft Trampoline with Safety Enclosure P/N: UNJ-U-11361A

Trademarks

JumpSport®, ProFlex™ Basketball Set, Game and Party Pak™, SureStep™ Trampoline Ladder, and BounceBoard Extreme™ are trademarks of JumpSport, Inc.

All other brand or product names are trademarks or registered trademarks of their respective companies or organizations.

Patents

This product includes technology associated with one or more of the following U.S. Patents:

No. 6,053,845

No. 6,261,207

No. 6,840,891

No. 6,846,271

No. 7,060,001

Additional Patents Pending.

How to Contact Customer Support

Should you require customer service or technical support for your JumpSport 10ft x 17ft Safety Enclosure, please contact JumpSport's Customer Service department at:

408-213-2551

8:00am – 5:00pm Monday through Friday, Pacific Time



Contents

Chapter 1	Introduction	5
	JumpSport ProFlex Basketball Set	6
	Game and Party Pak	6
Chapter 2	Assembly and Installation Instructions	7
	Preparation	7
	Trampoline Placement	7
	Tools	8
	Parts List	8
	Assembly	10
	Final Steps	21
	Disassembly	21
Chapter 3	Care and Maintenance Instructions	23
	Inspection	23
	Cold Weather Protection	23
	Replacement Parts	23
	Disassembly	23
	Care and Maintenance Safety Checklist	24
	Windy Conditions	25
	Moving the Trampoline	25
	Care	25
Chapter 4	Warning Information	27
	Points of Safety	27
	Before you Jump, Read this:	27
	Landing on Springs or Frame	28
	Bouncing off the Trampoline	28
	Landing Incorrectly on the Mat	28
Chapter 5	Use Instructions	29
	Safety Rules	29
	Basic Skills	30
	Bouncing	30
	Stop Bounce	30
	Arm Action	30
	Bounce Variations	31
	Basic Landing Positions	31
	Seat Drop	31
	Hands and Knees Drop	32
	Front Drop	32
	Series of Drops	33
	Twisting Moves	33
	Swivel Hips	33
	Turntable	34
	Twist Variations	34
	Warranty Information	Last Page

(This page left intentionally blank.)

Congratulations on purchasing a JumpSport 10ft x 17ft Safety Enclosure! We sincerely believe that you have purchased the finest safety enclosure on the market. It has been engineered with safety, durability, and performance in mind.

Safe use of a trampoline also requires adequate knowledge of technique, as well as what *not* to do. Please read this manual thoroughly for key points of safety.

Trampolines, being rebounding devices, propel the performer to unaccustomed heights and into a variety of body movements. Therefore, it is emphasized that all purchasers, and all persons using the trampoline, become familiar with the rules for safe use. Misuse and abuse of this trampoline is dangerous, and can cause serious injuries. The purchaser/user of this piece of equipment is assuming a degree of risk for which JumpSport cannot be responsible.

Read this information thoroughly before allowing the trampoline to be used. Keep this manual available for your review, and for review by all potential users. If there are questions please call JumpSport for further explanation.

Caution

Many users of our trampolines are children, and therefore need close supervision and rules to follow while playing on the trampoline. These rules must be enforced by whomever is responsible for the care of the children. It is strongly recommended that the buyer of this product go over the rules and recommendations in the packet of information supplied, including those in this manual. It is also strongly recommended that these rules and recommendations be supplemented with those of your own, for example: the time that jumping is allowed, when neighbors can visit, and so on. These rules and recommendations should be reviewed with anyone who is going to jump on the trampoline. If it is possible, review these rules with the parents or guardians of any visitors who may be jumping on the trampoline. See *Safety Rules* (under the *Use Instructions* section) for more information.

Introduction

JumpSport ProFlex Basketball Set

Let's face it, kids have to look up a lot: at parents, teachers, and bigger brothers/sisters. With the **JumpSport ProFlex Basketball Set**, look down for a change!

Whether you are into practicing your outside shot or improving your up-close game, the **ProFlex Basketball Set** is a fun way to avoid homework. Heck, athletic scholarships pay for college too!



- Our most popular accessory!
- Easily installed to your safety enclosure
- Set includes basketball

Don't miss out on these fun accessories and more at www.jumpsport.com !

Game & Party Pak

Bring the party to your trampoline! The **Game & Party Pak** is a great way to take turns and have fun participating in games while you are waiting.

Convince your parents that games provide the "structure" you need in your life, and that the **Game & Party Pak** is just the solution. Plus, you can tell them the Party Pak does big words like:

- Enhances Athletic Building Blocks
- Develops Agility, Stamina, Balance, Coordination
- Improves Spatial Awareness

(They won't be able to turn you down!)



Set Includes:

- Illustrated book of 20 games
- 3 soft balls
- 4 shock cords
- 1 box of sidewalk chalk
- Hours of fun!

Assembly and Installation Instructions

2

Preparation

Before you begin assembling your JumpSport 10ft x 17ft Safety Enclosure, make sure your trampoline is in a proper location.

Trampoline Placement



Caution: *When deciding on where to place your trampoline, consider the following:*

WARNING

Overhead Clearance	Adequate overhead clearance is essential. A minimum of 24 feet from ground level is recommended. Provide clearance for wires, tree limbs, and other possible hazards.
Lateral Clearance	Lateral clearance is essential. Place the trampoline and trampoline enclosure away from walls, structures, fences, and other play areas. Maintain a clear space on all sides of the trampoline and trampoline enclosure.
Level Surface	Place the trampoline and trampoline enclosure on a level surface before use.
Lighting	Use the trampoline and trampoline enclosure in a well-lighted area. Artificial illumination may be required for indoor or shady areas.
Security	Secure the trampoline and trampoline enclosure against unauthorized and unsupervised use.
Ground Clearance	Remove any obstructions from beneath the trampoline and trampoline enclosure.

Note: *The trampoline enclosure is only to be used as an enclosure for a trampoline and the trampoline must be of the appropriate size as covered by the specific enclosure.*

Note: *The owner and supervisors of the trampoline are responsible to make all users aware of practices specified in the Use Instructions.*

IMPORTANT: *The best surface on which to place your trampoline is dirt or grass. However, if you plan to install the trampoline on a very hard surface such as concrete or asphalt, a dense foam — similar to what can be found in public playgrounds — should be installed under each leg. Contact JumpSport Customer Service if you have any questions.*

It is the responsibility of the purchaser to become familiar with all of the information in this booklet, to convey the warnings to all users, and to enforce JumpSport's rules for safe use.

This unit is not intended for commercial or public use and is therefore strictly prohibited.

The maximum user weight is 230 pounds.

Assembly and Installation Instructions

Tools

Installation of the safety enclosure requires a 13mm hex wrench and a 5mm Allen wrench, both of which are included in the safety enclosure box (see Reference #8 and #9). An 8 foot A-Frame ladder will be useful for some steps (use care and follow procedures for use). Safety glasses and gloves are also recommended for safety.

Parts List

Your 10ft x 17ft Safety Enclosure is shipped with the parts shown below. Some parts will be located a smaller inner box. If any parts are missing, immediately call JumpSport Customer Service at 408-213-2551.

Note: Do NOT discard the foam tubing (Reference #3 and #4), as it is used as part of the pole assemblies. It is not just packing material. Not all poles will have foam around them. And do NOT remove any plugs from the ends of any of the support poles.

Reference #	Part #	Description	Quantity
1	POL-A-10918A	Lower support pole, with snap-button	8
2	POL-P-10915A	Upper support pole, notch at one end	8
3	FOA-P-10692A	Long foam tubing (1 tube packed over 1 pole)	8
4	FOA-P-10693A	Short foam tubing (2 tubes packed over 1 pole)	8
5	SLE-P-11581A	Pole sleeve, blue vinyl	8
6	CAP-P-10075A	Ball end cap	8
7a	BOL-P-10728A	M8 bolt, Allen head	16
7b	SPA-P-10083A	Pole spacer, black	16
7c	WAS-P-10082A	Washer	32
7d	NUT-P-10084A	M8 Nylock nut	16
7e	NUT-P-10622A	M8 acorn nut, capped end	16
8	TOO-P-10158A	Wrench, 13mm hex	1
9	TOO-P-10159A	Wrench, 5mm Allen	1
10	NET-P-10712A	48ft x 7ft heavy-duty net	1
11	BUN-P-10695A	7ft bungee, loop at one end, hook at other end	10
12	BUN-P-10696A	10ft bungee, loop at one end, hook at other end	2
13	STR-P-10697A	13ft pole strap, loop at one end	8

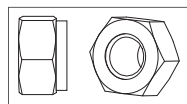

← Nylock nut (Ref. #7d)



← Acorn nut (Ref. #7e)

Assembly and Installation Instructions

The following pages contain diagrams, pictures, and written instructions for assembling your JumpSport Safety Enclosure. The “Ref. #” mentioned in many steps is referring to the “Reference #” column of the parts list on the previous pages.

Familiarize yourself with the Assembly and Installation Instructions before beginning installation.

For installation questions, please contact JumpSport’s Customer Service department at:

408-213-2551

8:00am – 5:00pm Monday through Friday, Pacific Time

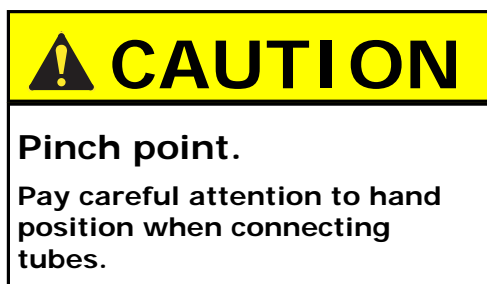

Assembly and Installation Instructions

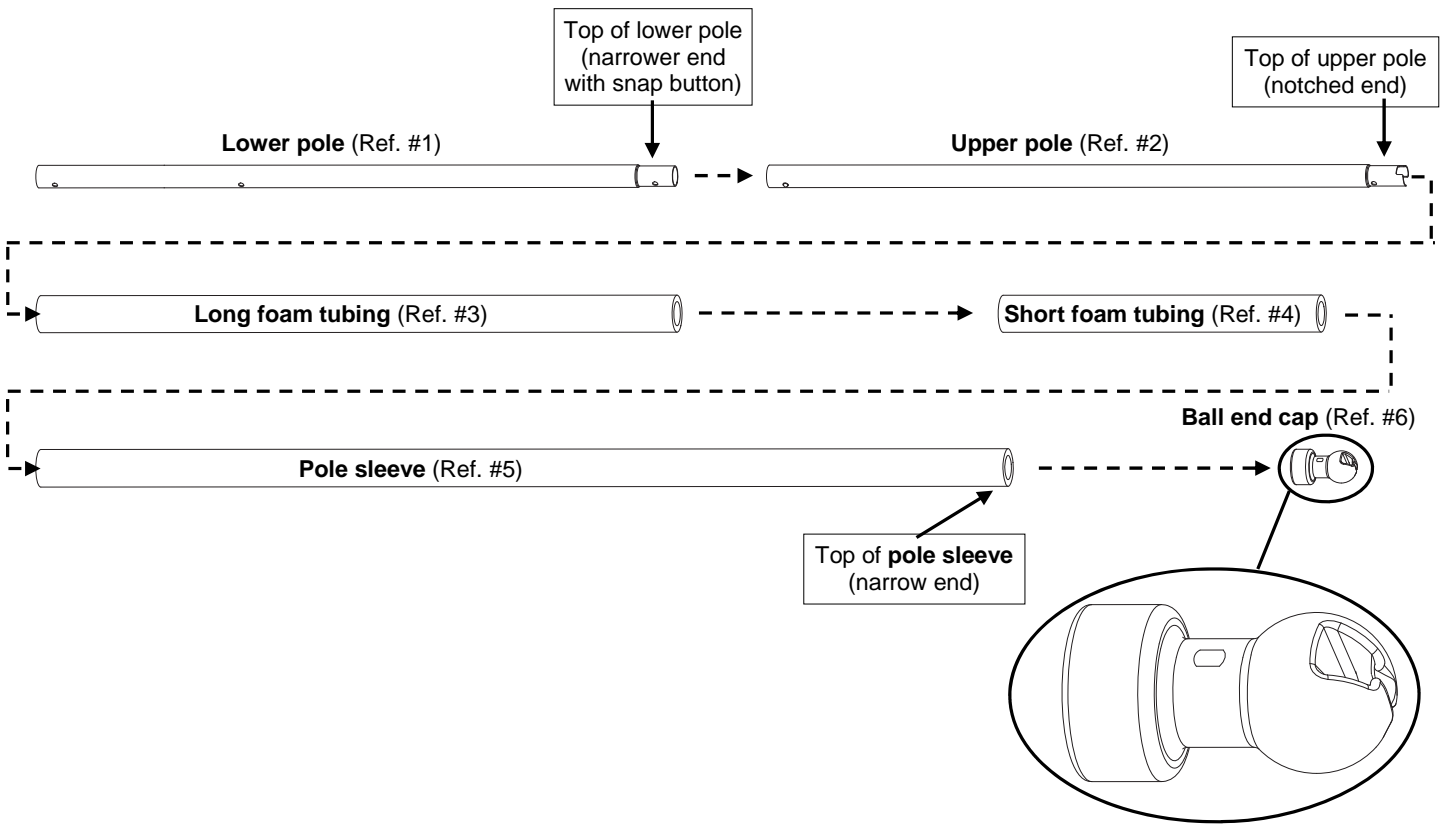

1) Build all pole assemblies as shown. (Pole sleeve and foam will fit up inside ball end cap.)

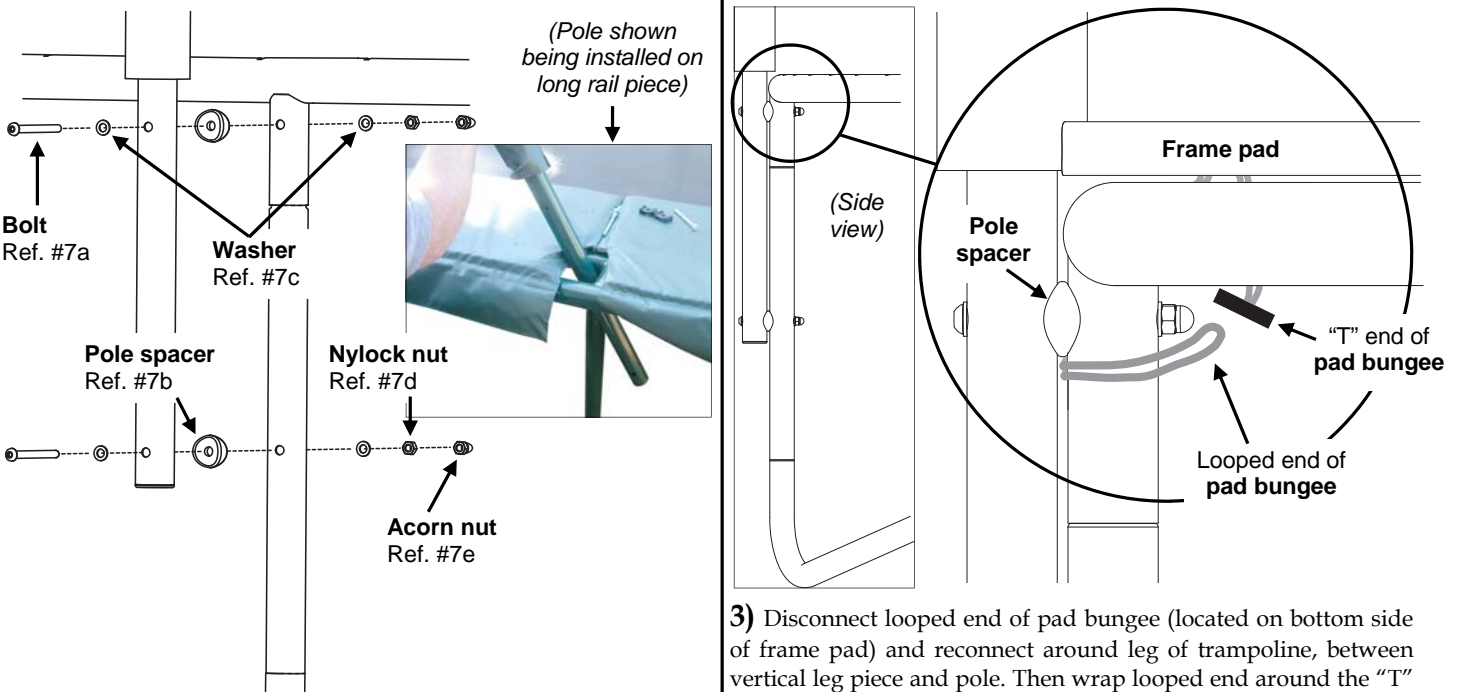

2) Using the tools and hardware provided, connect a pole to the outside of each trampoline leg. Holes on bottom of pole will have indentations on 1 side. Indentations must face in toward vertical leg. Snugly tighten bolts and Nylock nuts with wrenches. Hand-tighten acorn nuts.

3) Disconnect looped end of pad bungee (located on bottom side of frame pad) and reconnect around leg of trampoline, between vertical leg piece and pole. Then wrap looped end around the "T" on the opposite end of the bungee. Be sure the bungee wraps beneath the top pole spacer, as shown. Then at each corner of the trampoline, secure pad bungee around frame with looped end around "T" end.

Note: Be sure pad bungee can move freely after connecting around leg of trampoline.

Assembly and Installation Instructions

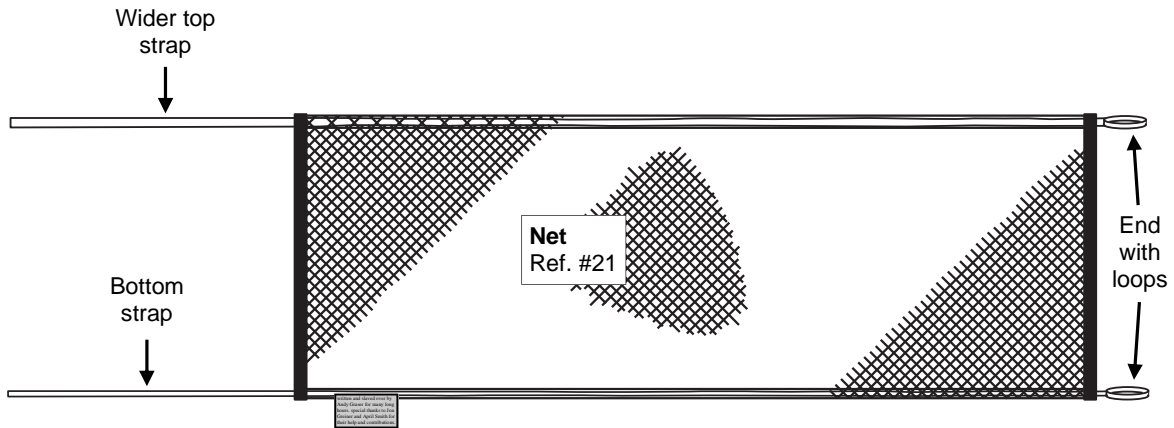

4) Familiarize yourself with the net. The net has a wider strap at the top of the net.

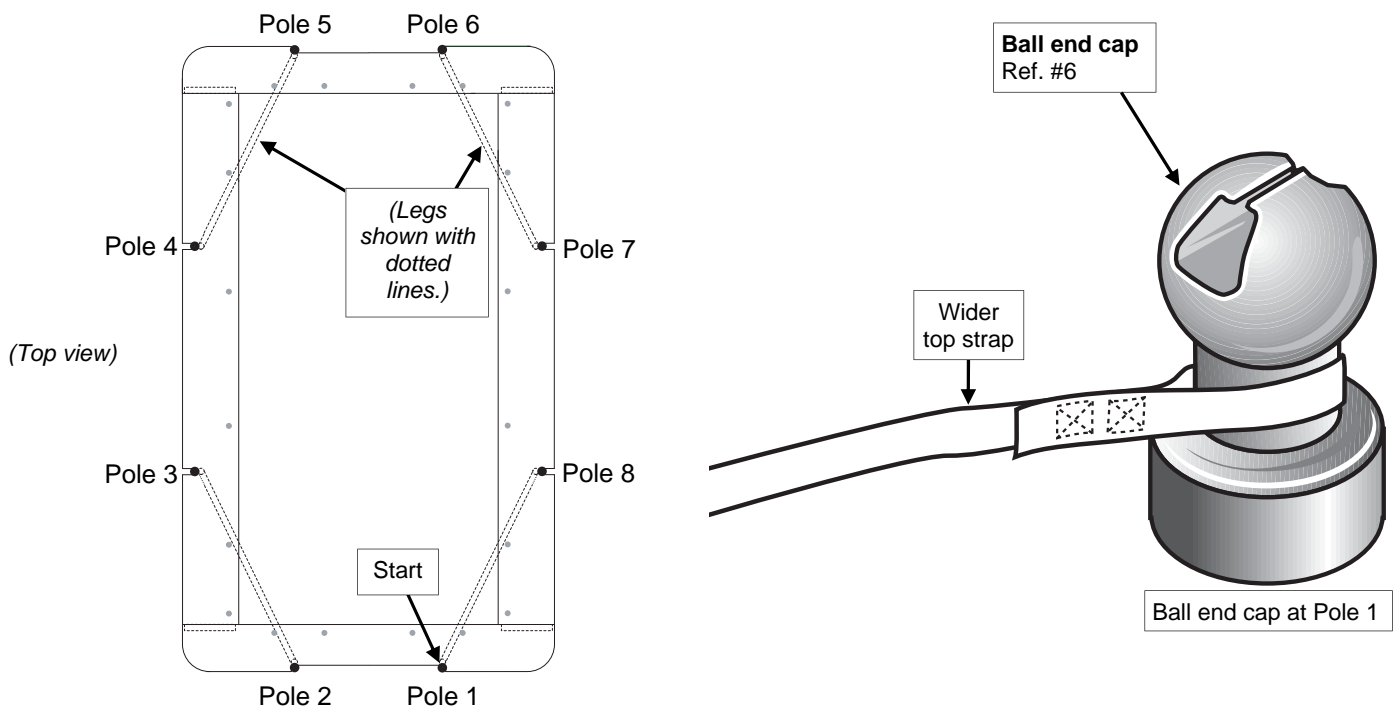

5) Top strap of net is slightly wider than bottom strap. Wider strap *must* be at top of net. Place looped end of top strap of net around ball end cap at pole 1.

Assembly and Installation Instructions

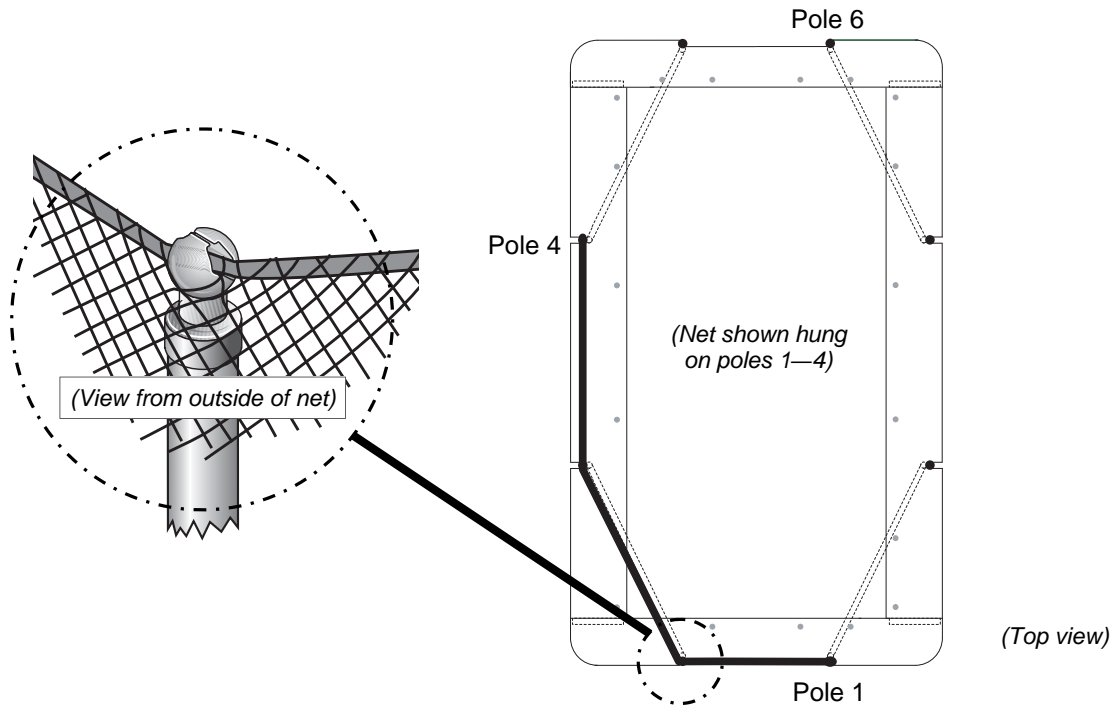

6) Hang net clockwise around outside of all poles. Top strap and 1 mesh of netting both rest in groove on top of ball end cap. Top strap should hang slightly curved between poles.

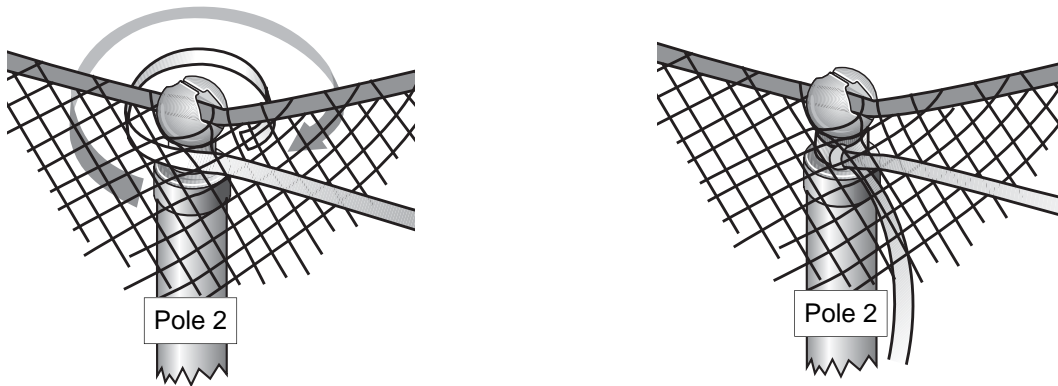

7) Continue back to pole 1. Hang net around outside of pole 1, with top strap and 1 mesh of netting resting in groove on top of ball end cap. Then pull net to pole 2. Feed top strap through top of net near pole 2. Wrap top strap around ball end cap to secure it. Then tie a double knot in the strap. Loosely wrap excess strap around pole 2, and tie off loose end toward bottom of pole.

Note: Bottom of net may not be touching trampoline at this time. This is normal.

Assembly and Installation Instructions

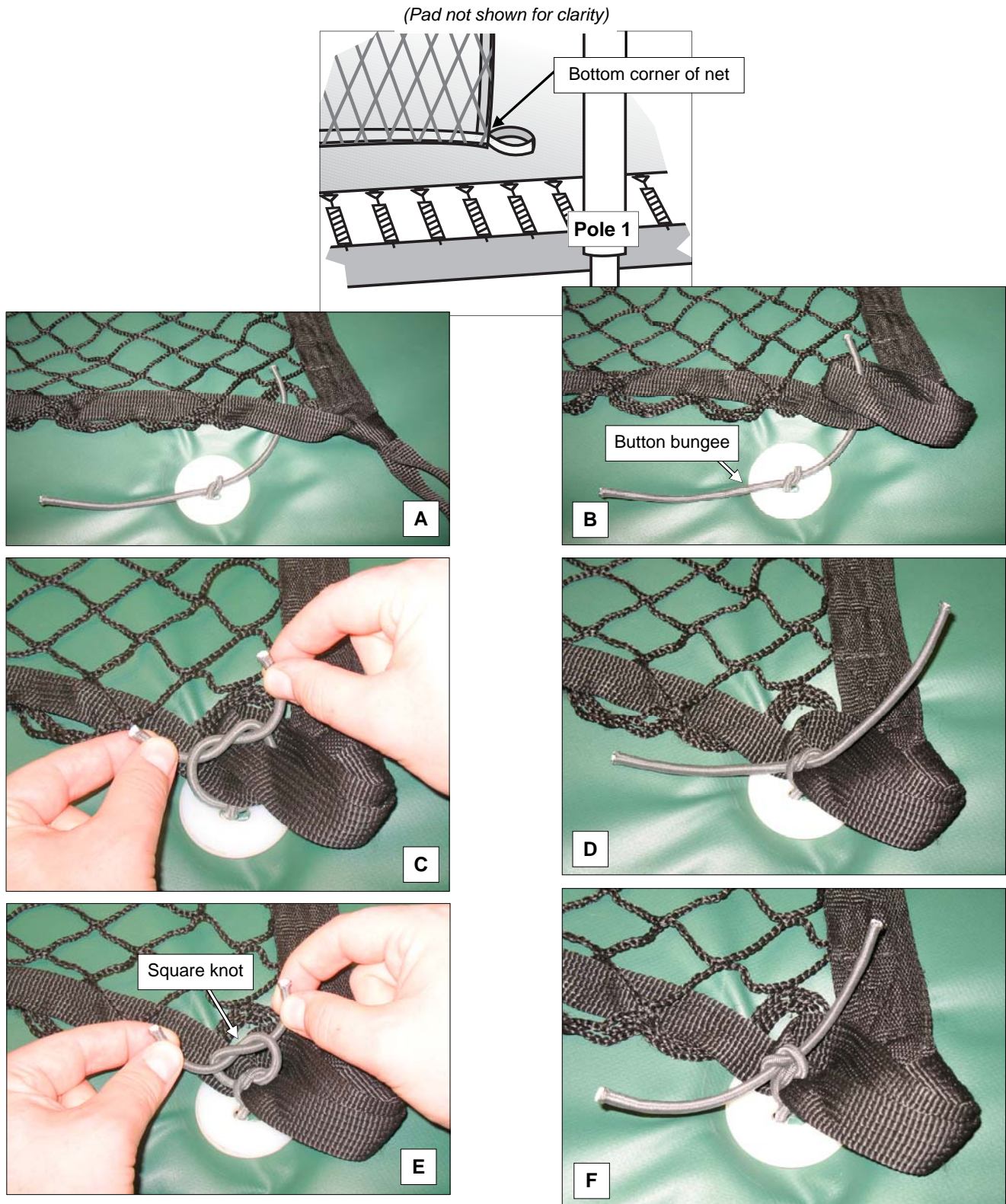

8) At starting edge of net (where you first hung the net on pole 1), find the bottom corner. Pull bottom corner toward pole 1. Attach bottom strap of net and looped end of net to frame pad using factory-installed button bungee, as shown. Secure button bungee to bottom strap with a square knot, as shown.

Note: Do not wrap bungee around net mesh, only around bottom strap of net.

Assembly and Installation Instructions



9) The skirt of the frame pad will be hanging down between the 2 poles on each side of the trampoline. Tuck pad skirt up underneath pad, so skirt is wedged between bottom of pad and rail of trampoline. Do this on all 4 sides of the trampoline.



10) At outer panel of net, pull the bottom strap so that bottom corner is approximately 18 inches from pole 2. Secure bottom strap around trampoline rail with a strong knot. There should now be an "hourglass" shape at the overlapping doorway.

Assembly and Installation Instructions

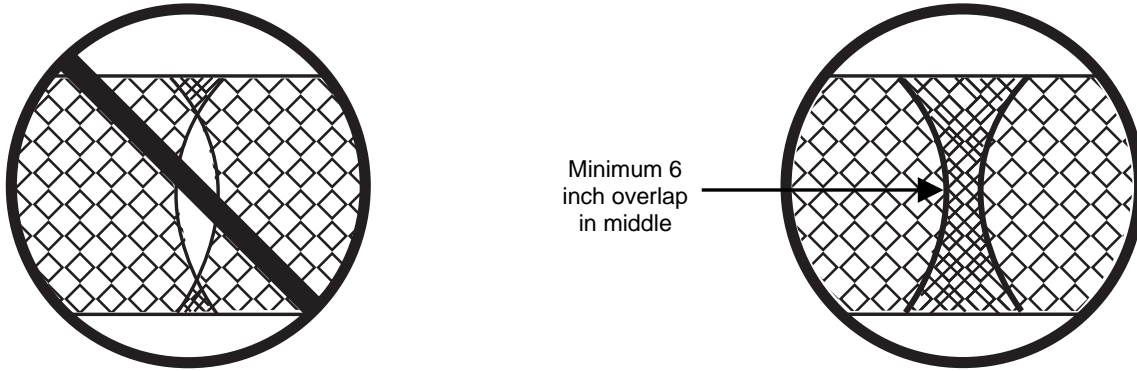

11) When hung correctly, the inner and outer panel of net should overlap by at least 6 inches in the middle. It can overlap by more, but should not be much closer than 8 inches to pole 2.

IMPORTANT: If the net does not overlap by at least 6 inches in the middle, STOP. Do NOT continue with the installation. Go back to Step 5. Rehang net, being sure to pull it snugly from one pole to the next.

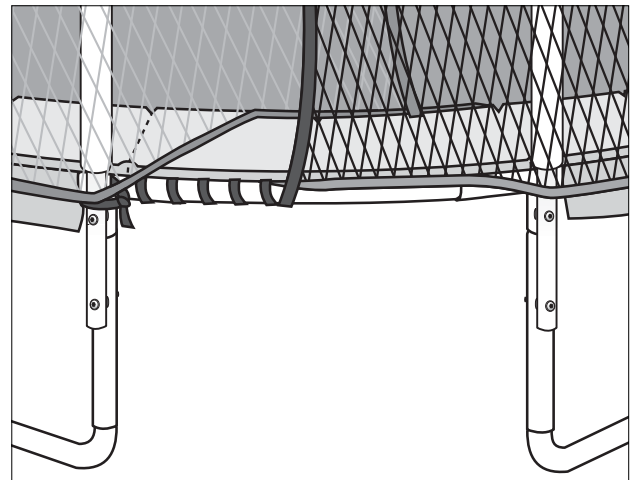
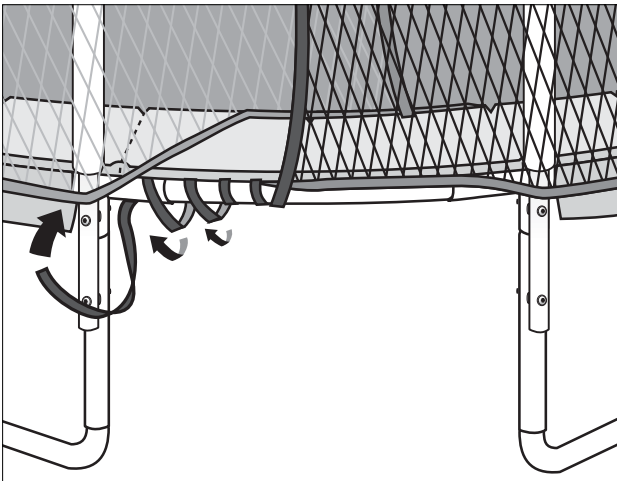

12) Securely wrap bottom strap around rail toward pole 2. Tie a knot around pole 2 to secure the strap to the rail. You should still have a minimum of 6 inches of overlap at the entryway.

Assembly and Installation Instructions

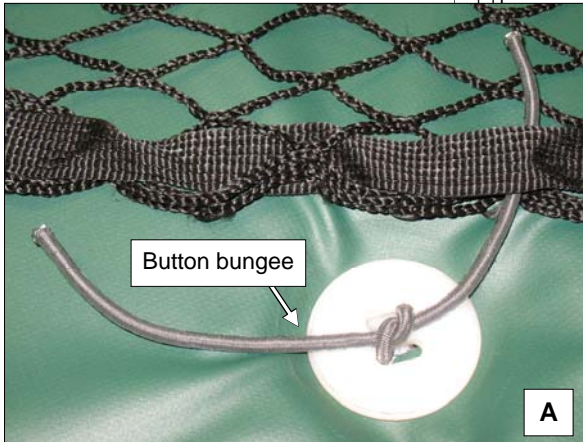
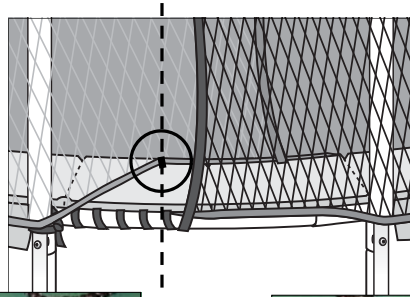

13) At overlapping doorway, find the 2 button bungees on top of frame pad. Secure bottom strap of inner panel of net at each button bungee with a square knot, as shown.

Note: Do not wrap bungee around net mesh, only around bottom strap of net.

Assembly and Installation Instructions

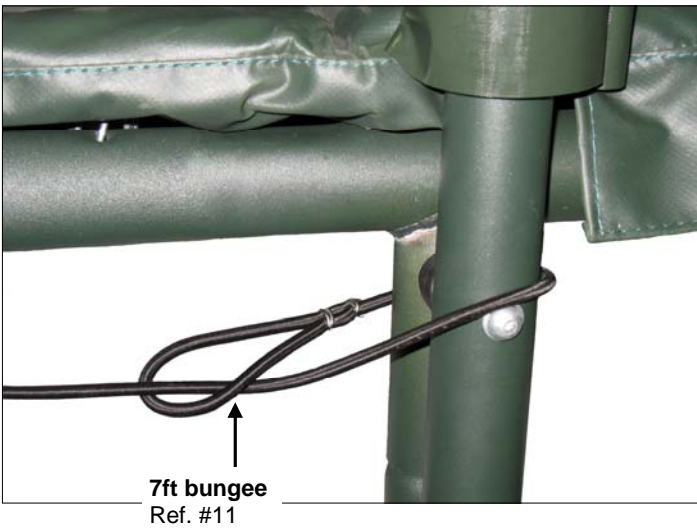

14) Wrap a 7ft bungee around pole 1 and vertical leg piece as shown. Bungee must wrap around pole and leg below the rail, and behind the 7ft bungee. Then pull end with hook all the way through looped end.

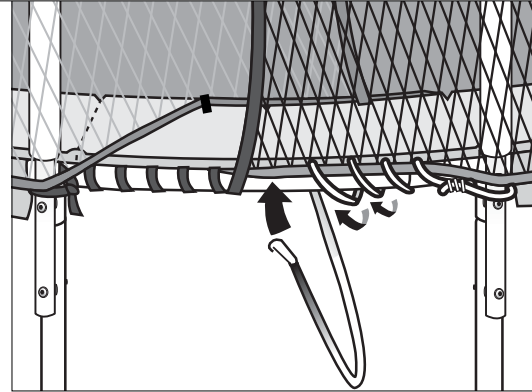
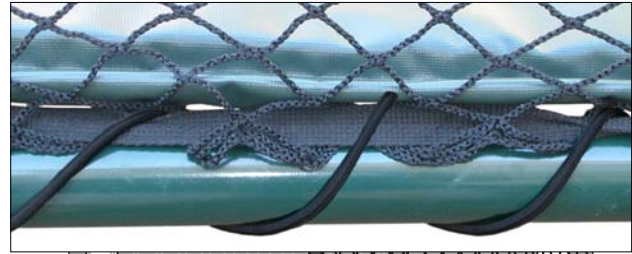

15) Wrap 7ft bungee around rail and through bottom strap of outer panel of net. Continue wrapping bungee around the rail and bottom strap until you get to the end of the net. Bungee should wrap once around rail between each spring before getting to end of net.

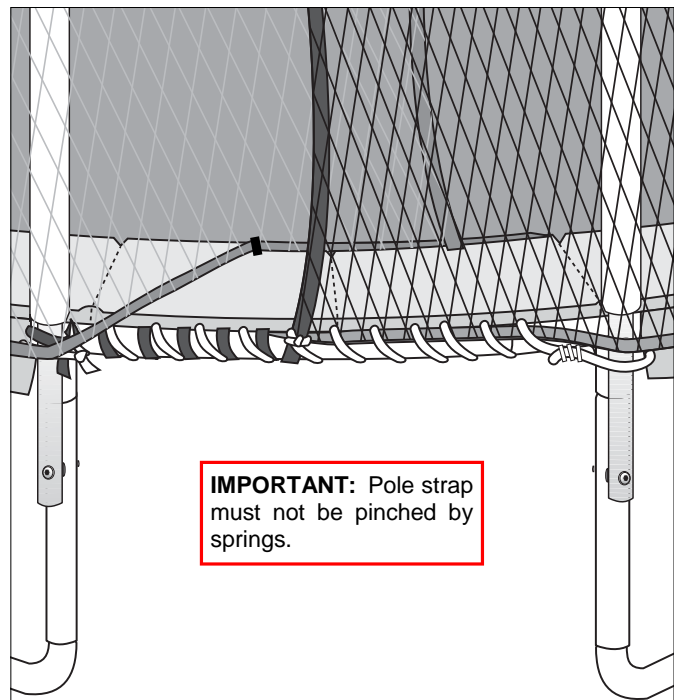

16) Continue wrapping 7ft bungee around rail toward pole 2. Secure bungee around pole 2 by connecting the end with hook back to bungee, as shown.

Assembly and Installation Instructions

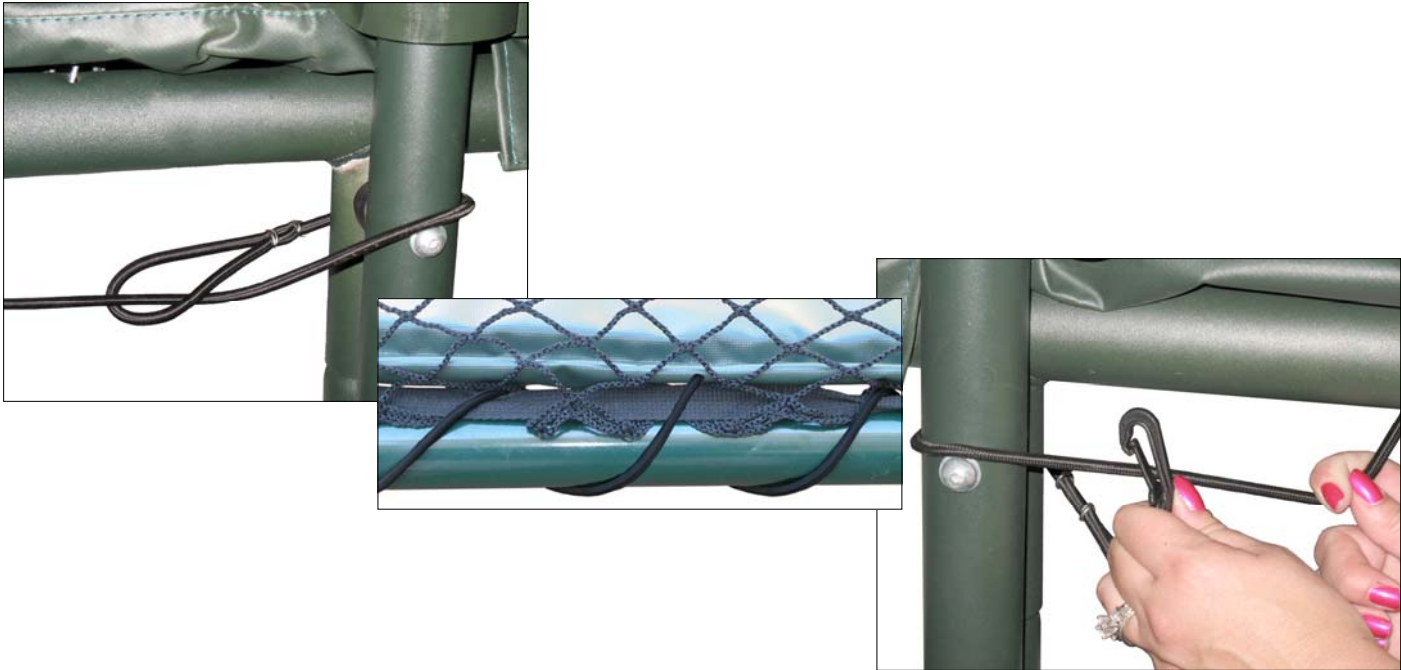

17) Using a 7ft bungee at the end opposite the overlapping doorway, and 10ft bungees on the long sides of the trampoline, connect bottom edge of net to frame:

- Connect looped end of bungee to trampoline as shown in Step 14.
- Wrap bungee around rail and through the bottom strap of net until you get to the next pole.
- Connect end with hook as shown in Step 16.

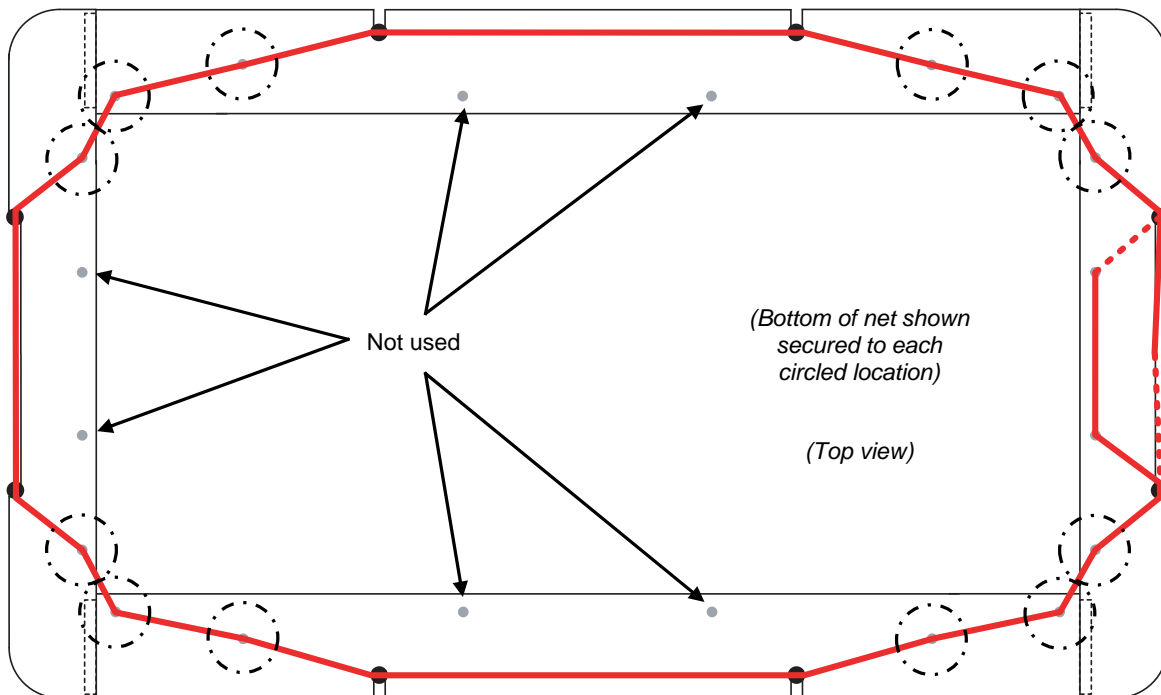

18) Secure bottom strap of net to each button bungee sticking out of top of frame pad, as circled above. Each bungee is sticking out of the top of the frame pad. Tie bungee to bottom strap of net as shown in Step 13.

Note: Do not wrap bungee around net mesh, only around bottom strap of net.

Assembly and Installation Instructions

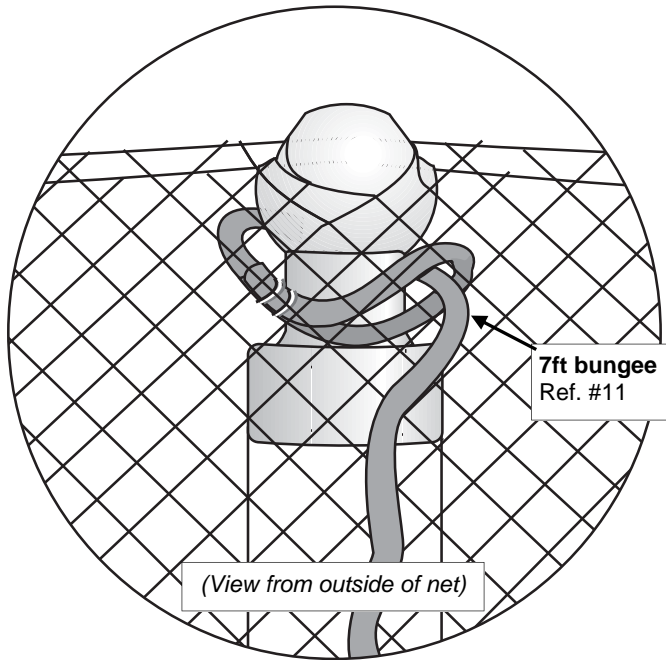

19) At top of net, wrap a 7ft bungee around ball end cap. Then pull hooked end of bungee all the way through looped end of bungee so that bungee is snug.

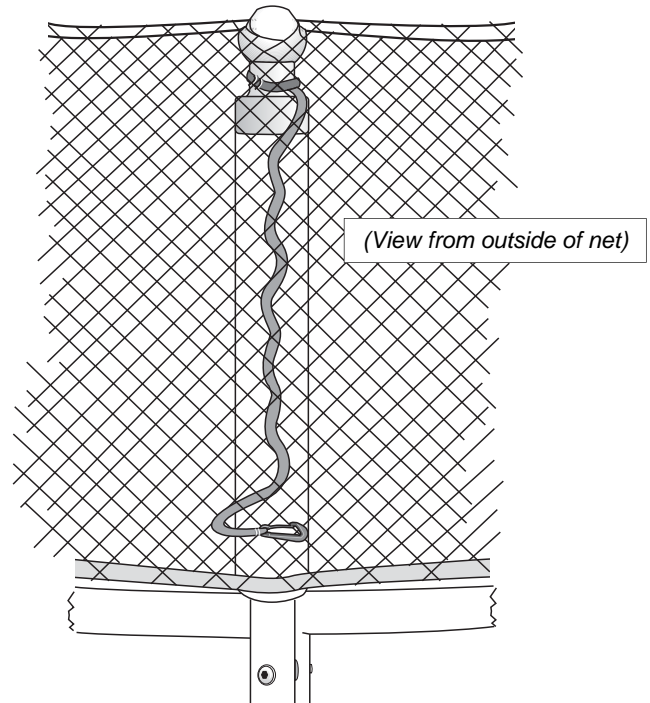

20) Weave 7ft bungee in and out of approximately every 3 squares of net, on outside of pole. Bungee will weave on inside of net for 3 squares, outside of net for 3 squares, inside of net for 3 squares, etc.

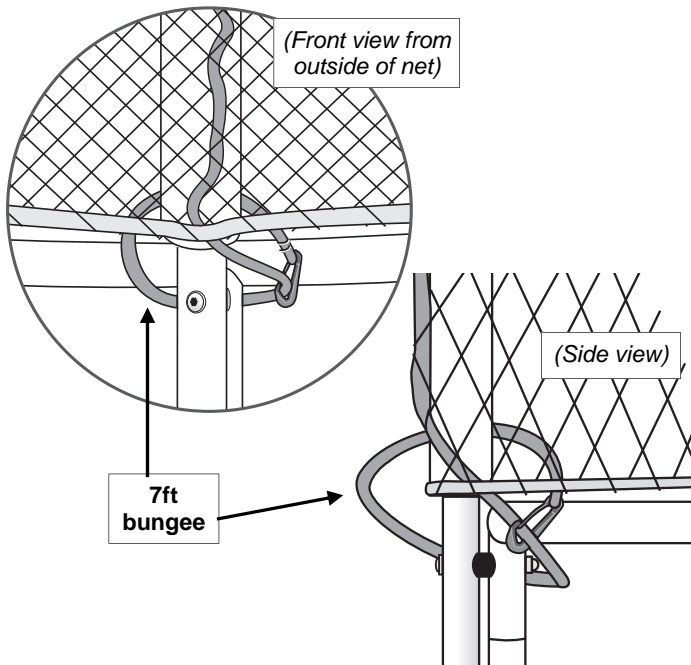

21) Wrap 7ft bungee around vertical leg piece, under trampoline rail. Secure hooked end of bungee to bungee, between pole and rail, as shown.

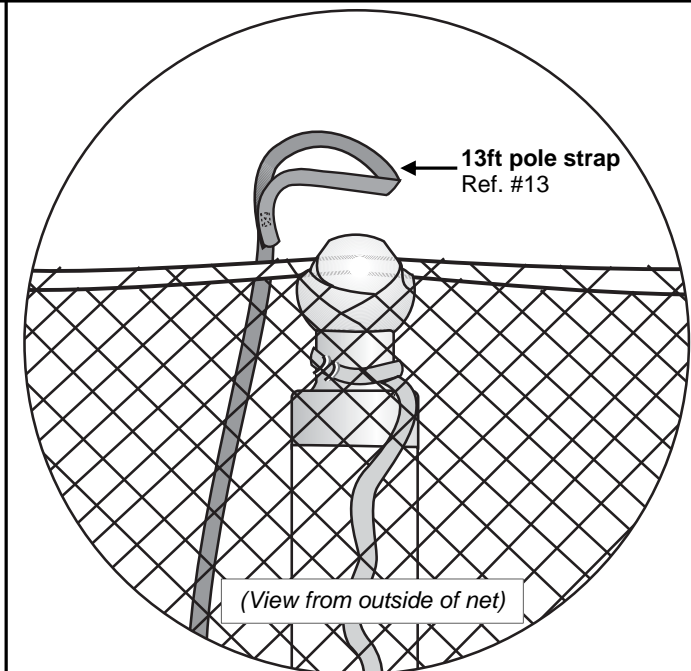

22) Place loop of 13ft pole strap in slot of ball end cap. 13ft pole strap should hang on *inside* of net.

>> Repeat Steps 19–21 at all remaining poles.

Assembly and Installation Instructions

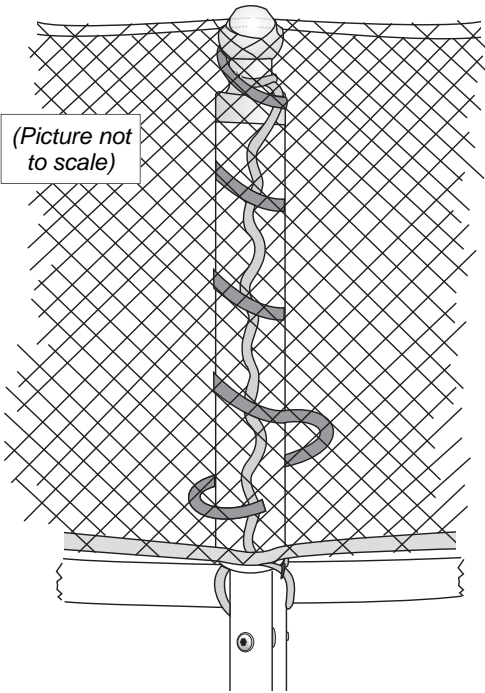

23) Wrap 13ft pole strap around pole and around 7ft bungee on inside of net. This will create approximately 5–8 wraps.

Note: Do not wrap 13ft pole strap through net mesh. Only wrap it around the 10ft bungee on the inside sections of the net.

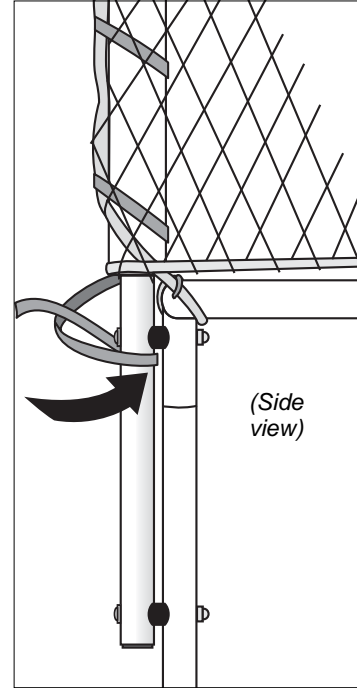

24) Tie end of 13ft pole strap off with a strong knot at bottom of pole, just below rail.

Note: When you are done, the strap should be wrapped and tied so that there is no excess hanging.

>> Repeat Steps 22–24 at all remaining poles.

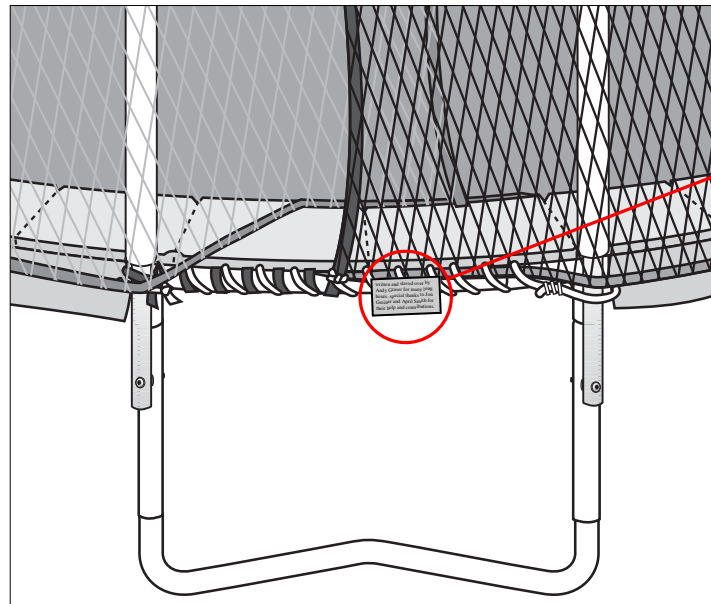

25) Be sure the warning placard attached to the bottom strap of net (at the doorway) is clearly visible at all times.

Final Steps

Assembly is now complete! Make sure all parts are securely assembled. Before using your JumpSport 10ft x 17ft Safety Enclosure, familiarize yourself and all users with the *Care and Maintenance Instructions, Warning Information, and Use Instructions* included in this manual. See Diagram 1, below, to see how to properly enter the safety enclosure.

To register your JumpSport 10ft x 17ft Safety Enclosure, visit our webpage at www.jumpsport.com and click on the [Product Registration](#) link.

Note: The upper and lower support straps may need periodic tightening. Check the knots and straps regularly. If the net sags due to extended use, we recommend repeating Steps 5 through 24.



WARNING: Trampoline use is not recommended without the frame pad installed. The frame pad is designed to reduce the possibility of injury by protecting the user from coming into contact with the frame and springs of the trampoline. It is very important that you properly attach the frame pad securely to the frame and in the correct position prior to using the trampoline.

Disassembly

To disassemble your JumpSport 10ft x 17ft Safety Enclosure, follow the assembly steps in reverse order.

Diagram 1
(Top view)

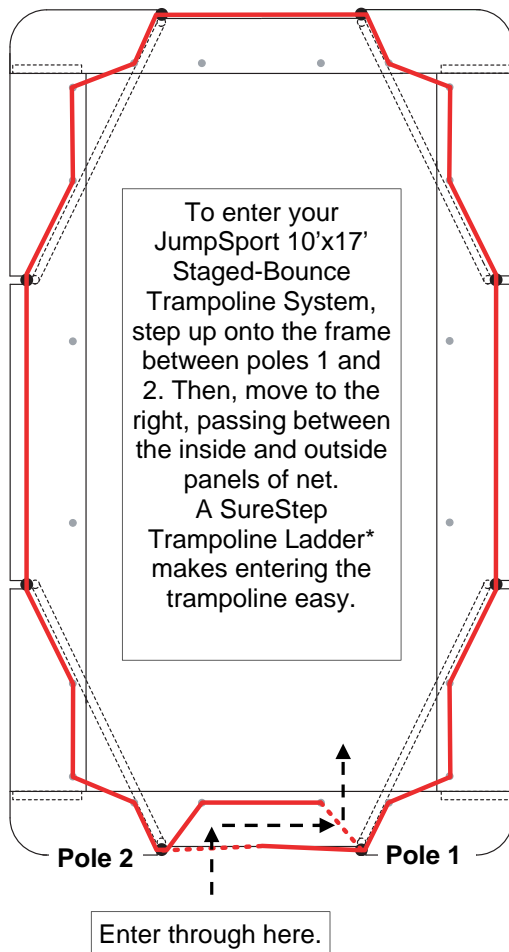

*For more information about the SureStep Trampoline Ladder, the ProFlex Basketball Set, the BounceBoard Extreme, and other great trampoline accessories, visit our website at www.jumpsport.com

Assembly and Installation Instructions

(This page left intentionally blank.)

Care and Maintenance Instructions

3

Your JumpSport 10ft x 17ft Safety Enclosure is made using quality materials and is finely-crafted to provide you and your family with many years of enjoyment and exercise. Proper maintenance and care will help to prolong the life of the trampoline and reduce the possibility of injury.

All trampolines require maintenance at some point. Springs may need to be replaced, rail pieces may become bent, stitching in the mat and frame pads may rot out. The following maintenance guidelines should always be observed.

Inspection

Inspect the trampoline enclosure before each use and replace any worn, defective, or missing parts. The following conditions could represent potential hazards:

- Missing, improperly positioned, or insecurely attached barrier or enclosure support system (frame) padding and pole caps
- Puncture, frays, tears, or holes worn in the barrier or support system (frame) padding
- Deterioration in the stitching or fabric of the barrier or support system (frame) padding
- Ruptured springs
- Bent or broken support system (frame)
- A sagging barrier
- Sharp protrusions on the support system (frame) or suspension system

Note: The “bed” mentioned above and elsewhere in this manual, refers to the jumping surface (generally referred to as the “mat”). The “barrier” mentioned above and elsewhere in this manual, refers to the safety enclosure netting. The “frame” mentioned refers to the rail assembly pieces of the trampoline.

If any of the above conditions exist, your JumpSport 10ft x 17ft Safety Enclosure must be disassembled or otherwise protected against use until the condition is remedied.

Cold Weather Protection

The JumpSport 10ft x 17ft Safety Enclosure is designed for year-round outdoor use. However, in climates of cold weather where snow and ice are common, we recommend the net be removed and stored in a dry area out of the sun. To remove the net, simply complete the instructions for installing it in reverse order.

Replacement Parts

All replacement parts should be ordered through JumpSport.

Call **JumpSport** at 408-213-2551 if you need replacement parts, or have any questions.

If any warning labels or signs become unreadable or missing, call JumpSport for free replacements.

Disassembly

To disassemble, follow the assembly steps in reverse order. See the Assembly Instructions beginning on page 10.

Care and Maintenance Instructions

Care and Maintenance Safety Checklist

Note: *Inspect the trampoline enclosure before each use and replace any worn, defective, or missing parts.*

Pole Foam The pole foam and vinyl pole sleeve life expectancy is two to five years. To increase the life of your pole foam and sleeves, do not allow people to grab them in order to pull themselves onto the trampoline.

Check for...	Necessary Action	Safety Check	
		Safe	Unsafe
Vinyl sleeve deterioration	Replace	_____	_____
Foam missing or deteriorating	Replace	_____	_____

Net The net, support straps, and bungee cords will require frequent inspection for deterioration or fraying. Life expectancy is three to five years for the net, and one to three years for the straps and bungees.

Check for...	Necessary Action	Safety Check	
		Safe	Unsafe
Faded and breaking top or bottom net strap	Replace straps	_____	_____
Brittle and tearing net	Replace	_____	_____
Cuts, tears, or holes in net or net straps	Replace	_____	_____
Missing warning labels	Call JumpSport for replacement	_____	_____

Steel Poles The pole life expectancy is for many years. To increase the life of your poles, do not allow people to grab them in order to pull themselves onto the trampoline.

Check for...	Necessary Action	Safety Check	
		Safe	Unsafe
Rust	Clean and paint	_____	_____
Structural failure	Replace	_____	_____
Bent frame	Repair or replace part	_____	_____
Sharp protrusions	Repair	_____	_____
Missing pole warning label	Replace	_____	_____

Safety Rules Review this manual with all jumpers. Maintain all warning labels and signs. If labels or signs become lost or unreadable, write or call JumpSport for free replacements.

Windy Conditions

It is possible for the trampoline to be blown about by a high wind. If you anticipate high winds, the frame should be secured to the ground with the use of an JumpSport Trampoline Anchor Kit. If you anticipate severe winds, the trampoline should be moved to a sheltered location or completely disassembled. Our anchor kit can be found in the **Accessories** section at www.jumpsport.com.

Diagram 2 JumpSport Trampoline Anchor Kit



Use a JumpSport Trampoline Anchor Kit to tie down the trampoline that your JumpSport 10ft x 17ft Safety Enclosure is attached to.

Moving the Trampoline

If you need to move your trampoline periodically, it should be moved by at least two people, and kept horizontal during the move. Both people should stand next to each other on one of the short ends of the trampoline, and lift that end of the trampoline. Rotate that end of the trampoline about five feet, then go to the opposite end of the trampoline, and do the same thing. This will slowly rotate each end of the trampoline toward your desired destination, and is the easiest way to move the trampoline due to its heavy weight. Disassemble the trampoline for any move greater than a few feet.

Care





Do not allow family pets on the trampoline, as claws may snag and pull the trampoline mat material or net material, or damage the frame pad or pole foam.

The JumpSport 10ft x 17ft Safety Enclosure is intended to be used by one person at a time, weighing less than 230 pounds.

Care and Maintenance Instructions

(This page left intentionally blank.)

WARNING

	DO NOT attempt or allow somersaults. Landing on the head or neck can cause serious injury, paralysis or death, even when landing in the middle of the bed.		DO NOT allow more than one person inside the trampoline enclosure. Use by more than one person at the same time can result in serious injury.
Use trampoline only with mature, knowledgeable supervision.			
	DO NOT attempt to jump over the barrier.		DO NOT intentionally rebound off the barrier. DO NOT hang from, kick, cut or climb on the barrier.

Points of Safety

It is essential that trampoline users follow a carefully planned safety program so that the trampoline can be fully enjoyed. Most accidents can be classified into the following:

- Before you jump
- Landing on springs or frame
- Bouncing off the trampoline
- Landing incorrectly on the mat

These are covered in detail in the following sections.

Before You Jump, Read this:

Please read the *Safety Rules* (under the *Use Instructions* section) with the following in mind:

- The trampoline enclosure is not designed to prevent injuries associated with unsafe use of the trampoline, or with more advanced skills like flips, somersaults, or acrobatic maneuvers. Do not attempt any of these activities.
- Each user should become familiar with the *Care and Maintenance Instructions*, *Warning Information*, and *Use Instructions* included in this manual.
- The trampoline enclosure does not replace the need for supervision by a responsible, knowledgeable adult.
- Allow only one person to use the entrance at one time.
- When exiting, do not jump off the edge of the trampoline. Always sit on the edge, then carefully lower your body onto the ground.
- Do not attach other apparatus to the trampoline enclosure unless it is a JumpSport-approved device. Any additional JumpSport accessory that you may attach to the trampoline enclosure must be attached and used only in accordance with the instructions for such accessory.

Warning Information

Landing on Springs or Frame

The risk of falling on the springs or frame, landing between the springs, or hitting the frame can be reduced by:

- Proper mounting and dismounting of the trampoline
- Jumping at the center of the mat without traveling toward the side
- Properly installing the frame pads
- Properly installing the safety enclosure

Simple frame pads or spring covers on their own do not give adequate protection. Installing the **JumpSport Safety Enclosure** and using spotters, will greatly reduce the risk of injury.

Bouncing off the Trampoline

Bouncing off of the trampoline can be controlled, if not completely eliminated, through:

- Proper instruction and mastering of the “Stop Bounce” technique in the “Basic Skills” section
- Maintaining a position in the center of the mat
- Strictly forbidding any “flying dismounts” (i.e. jumping off of the trampoline onto another object or the ground)
- Installing a **JumpSport 10ft x 17ft Safety Enclosure**
- Using spotters
- Using the trampoline only with mature, knowledgeable supervision

Keep objects away from the trampoline. It is dangerous to jump from the trampoline to the floor or ground. Do not jump from the trampoline into a swimming pool, onto a swing, or any other object. Do not install the trampoline on concrete, asphalt or hard compacted surfaces.

Landing Incorrectly on the Mat

Landing incorrectly on the mat creates great risk of a serious injury, with most injuries resulting from attempted somersaults/flips. It is strongly recommended that somersaults/flips are not performed.

Safety Rules

It is the responsibility of the owner to become familiar with the safety rules and to convey these rules to all users.

WARNING

- DO NOT attempt or allow somersaults on the trampoline. Landing on the head or neck can cause serious injury, paralysis, or death, even when landing in the middle of the bed.
- DO NOT allow more than one person inside the trampoline enclosure. Use by more than one person at the same time can result in serious injuries.
- Use trampoline enclosure only with mature, knowledgeable supervision.
- Inspect the trampoline enclosure before each use. Make sure the barrier and the enclosure support (frame) padding is correctly and securely positioned. Replace any worn, defective, or missing parts.
- Do not attempt to jump over the barrier.
- Do not attempt to crawl under the barrier.
- Do not intentionally rebound off the barrier.
- Do not hang from, kick, cut or climb on the barrier.
- Wear clothing free of drawstrings, hooks, loops or anything that could get caught in the barrier.
- Do not attach anything to the barrier that is not a manufacturer-approved accessory or part of the enclosure system.
- Enter and exit the enclosure only at the enclosure door or barrier opening designated for that purpose.
- Read all instructions before using the trampoline enclosure. Warnings and instructions for the care, maintenance, and use of this trampoline enclosure are included to promote safe, enjoyable use of this equipment.

Note: *The "barrier" mentioned above and elsewhere in this manual, refers to the safety enclosure netting. The "frame" mentioned refers to the rail assembly pieces of the trampoline.*

Use Instructions

Basic Skills

Basic trampoline skills include:

- Bouncing
- Stop Bounce
- Arm Action
- Bounce Variations

Bouncing

The most important basic skill in jumping on a trampoline, is controlling the height and landing of your bounce. The goal is to land in the center of the mat, or as close to the center of the mat as possible. The basic bounce should always be low. High, reckless bouncing should never be allowed.

Stop Bounce

The Stop Bounce technique allows the jumper to gain control by stopping quickly. It is done by keeping the feet in contact with the mat, and absorbing the rebound of the trampoline with the knees and waist. This skill should be learned right away and should be employed whenever you feel out of balance, or land away from the center area.

To learn the Stop Bounce:

1. Stand in center of the mat with your feet about hip-width apart.
2. Attempt three easy bounces; keep them low and controlled.
3. Focus your eyes toward the perimeter of the trampoline while bouncing, in order to keep your balance
4. Stop the bounce when your feet contact the mat by bending at your knees and hips.

Arm Action

Arms are very important for proper control and lift. Whenever you go up, your arms go up. They go up to a set position about shoulder height and shoulder width. They should remain in this balanced position until you start to go down. Then they circle down slightly behind the hips, ready to lift again as you bounce up. See Figure 2.

Figure 2 Arm Action

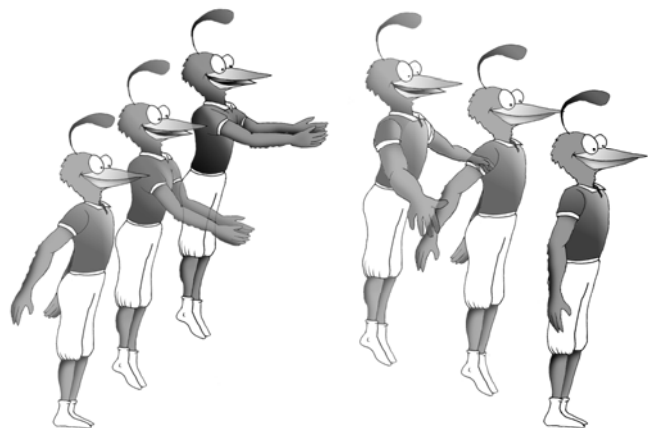

Bounce Variations

Figure 3 shows three variations you can perform in the air. These should be performed at the top of your bounce before returning to the normal landing position on your feet.

Figure 3 Bounce Variations



Tuck



Pike



Straddle

Practice these simple variations and concentrate on perfect form. When you are in position, make sure you point your toes and straighten your fingers (Pike and Straddle variations). Also make sure you take off and land in the same spot on the center of the mat.

These simple variations to the basic bounce can be a lot of fun, and are very important for gaining experience in coordinated movement and balance.

Basic Landing Positions

Once the jumper understands the body placement of the position, the drop can be performed after “priming” the trampoline mat. Priming is done by bending the knees and pushing down on the trampoline mat several times, thereby setting the mat in motion. The feet stay in contact with the mat during the entire priming motion.

Seat Drop

To perform a Seat Drop:

1. From the standing position, prime the mat several times.
2. Pick up your feet at the top of the last bounce, and sit down. You should land with your body in a seated position with your legs straight out in front of you and your toes pointed. Hands should be on the mat next to your hips. Fingers should be together and pointed toward your feet. See Figure 4.
3. Push on the mat with your hands to rebound up to your feet.

Figure 4 Seat Drop

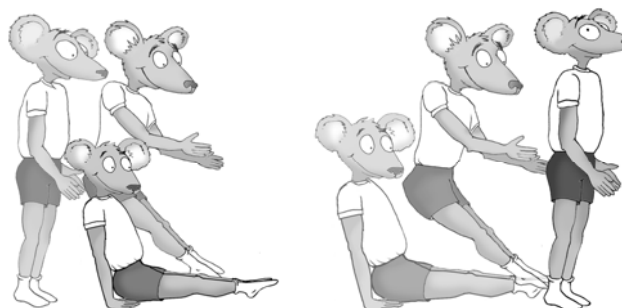

Use Instructions

Hands and Knees Drop

To do a Hands and Knees Drop properly, there should be just as much weight on the hands as on the knees. The back should be about parallel to the mat. The knees and hands should land simultaneously, with the middle of the body landing in the center of the trampoline. The hands should be directly under the shoulders. The knees should be directly under the hips. The toes should be pointed. See Figure 5.

To perform a Hands and Knees Drop:

1. Get down on your hands and knees on the mat. Make sure you have weight on both your hands and knees. Do not sit on your heels.
2. Remain in this position and try to bounce. Do not rock back and forth between the hands and knees, but develop an even landing on all four points.
3. From the standing position, prime the mat several times. Lift upward with the hips, reach forward with the hands, and land on all fours. Look slightly in front of your hands on landing. Push to rebound to your feet.

Figure 5 Hands and Knees Drop

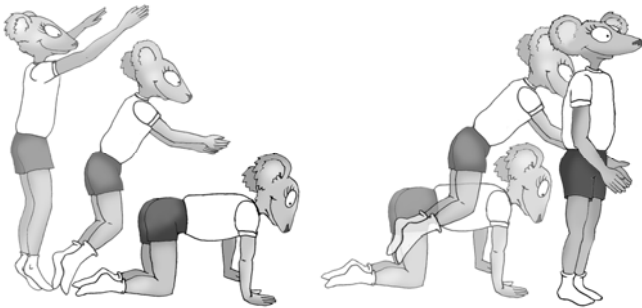

Front Drop

In a front drop, contact with the trampoline mat should simultaneously take place with your hands, elbows, chest, stomach, and hips. Knees should be bent. Hands should be placed close together with palms in contact with the mat, forming a triangle. Eyes should focus on the center of the triangle or slightly in front of your fingers. See Figure 6.

1. First learn how to go from the hands and knees drop to the front drop.
 - a. Start from the hands and knees drop position.
 - b. As you rebound from the hands and knees, stretch so that you land on your stomach. From this position, rebound to your hands and knees.
2. Next, perform Step 1, beginning and ending in a standing crouched position.
 - a. Start from a standing position with your knees bent and your upper body low and close to the trampoline mat.
 - b. Prime the mat several times.
 - c. Lift your hips gently upward and backward.
 - d. Land in a hands and knees drop, rebound and stretch into a front drop, and return to a hands and knees drop.
 - e. Push with the hands to return to your feet.
3. Lastly, perform Step 2 from a standing position.
 - a. Start from a straight standing position.
 - b. Prime the mat several times.
 - c. Perform a Front Drop as in Step 2.

Figure 6 Front Drop

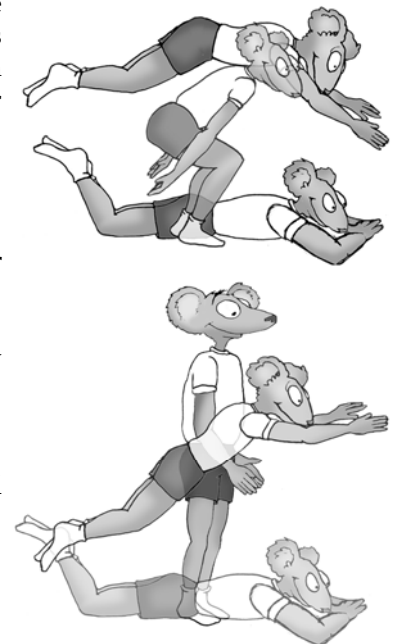

Front Drop Note: *Your body must contact the trampoline mat all at once. If you land on your chest and arms first, they will rebound before the knees hit, which will result in a straining action on the back. If this type of landing is made with a traveling, diving approach, there is a good chance that the elbows may become skinned. If the landing is made so that the knees and hips hit first, then they will rebound and you will land heavily on your shoulders and face.*

Series of Drops

Once you have mastered the individual bounce variations and drops, try performing them in sequence. For example: Seat Drop—Hands and Knees Drop—Front Drop or Seat Drop—Hands and Knees Drop—Seat Drop.

Twisting Moves

Twisting moves include:

- Swivel Hips
- Turntable
- Twist Variations

Swivel Hips

A Swivel Hips is a combination move consisting of a Seat Drop, half twist, then another Seat Drop.

1. First become familiar with the first part of a Swivel Hips.
 - a. Perform a seat drop.
 - b. Push down on the mat with the hands and straighten in the air with your arms stretched over your head.
2. Next, add the half twist.
 - a. Perform Step 1. As you rebound up to your feet, move one shoulder in the direction you want to twist.
 - b. Finish standing with arms stretched overhead, facing the opposite direction (180 degree twist completed).
3. Last, try the complete Swivel Hips twist. See Figure 7.
 - a. Perform a Seat Drop.
 - b. As you rebound with your arms overhead, twist around to face the opposite direction.
 - c. Land in another Seat Drop.

Figure 7 Swivel Hips

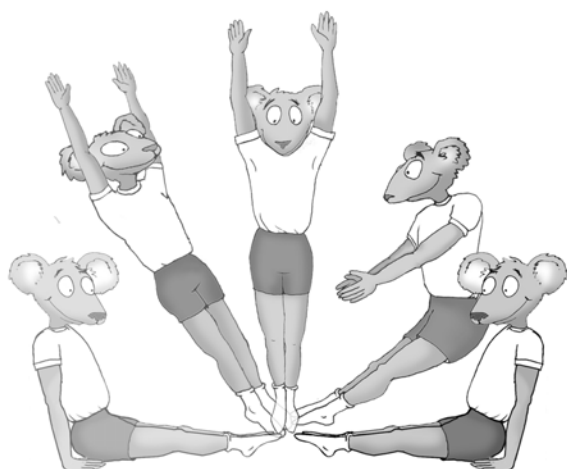

Use Instructions

Turntable

A Turntable is a combination move consisting of a Front Drop, a Half Twist, then another Front Drop.

Figure 8 Turntable

1. First become familiar with the first part of a Turntable.
 - a. Begin in a hands and knees position, with hands forming a triangle, like a Front Drop.
 - b. Prime the mat in this position.
 - c. Push backward with your hands and extend your body to land in the Front Drop position.
 - d. Repeat several times in succession: Hands and Knees Drop—Front Drop—Hands and Knees Drop, etc.
2. Next, perform the movement in Step 1, but at twice the speed so as to bring the knees inward, under the hips and out again without touching the knees on the mat.
3. Now, perform the movement in Step 2, but push sideways on the mat so that your body rotates before you land on the mat.
4. Last, try the complete Turntable twist from a standing position. Prime the mat and perform a Front Drop. Push sideways, complete a 180 degree rotation, and finish in a Front Drop facing the opposite direction. See Figure 8.

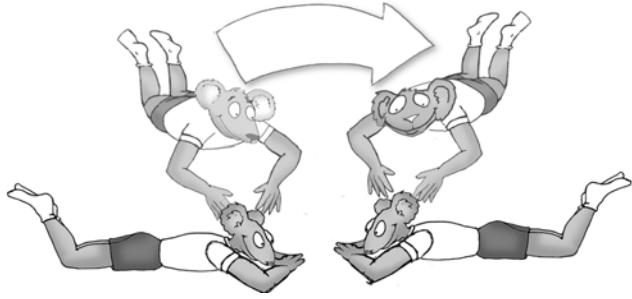

Twist Variations

You can have hours and hours of fun and challenging bouncing by combining twists with each of the basic landing positions (Drops). You can twist after the landing. For example: Seat Drop with a half twist and land on your feet.

You can add more twists. Always remember to practice and perfect the simpler twists before moving on to more complex twists.

You can also perform a series of twists. For example: perform several Swivel Hips in a row, all in the same direction or alternate directions. You can do the same thing with Turntable twisting.

If you find you love the trampoline and have mastered the moves discussed in these instructions, we encourage you to seek additional training from a certified trampoline instructor.

JumpSport®

One Year Limited Warranty

What is covered by this warranty? This warranty covers any defects in materials or workmanship on all of the components of the JumpSport 10ft x 17ft Safety Enclosure, and is extended exclusively to the original retail purchaser.

How long does this coverage last? Warranty coverage for each component begins from the original date of purchase and lasts for one year.

What will JumpSport do? If you return the defective part to JumpSport, as instructed below, JumpSport will either repair or replace such part, at JumpSport's discretion, and return it to you.

What is not covered by this warranty? This warranty does not cover expenses of on-site labor, travel, assembly or disassembly, or other charges associated with the repair or replacement of covered components. This warranty also does not cover any problem that is caused by abuse, misuse, commercial or public use, ordinary wear and tear, weathering, acts of God (such as wind and lightning), failure to follow directions, improper installation, or improper maintenance, or any silk screened graphics. Rust is a natural occurrence with any outdoor steel product and is likewise not covered by this warranty, to the extent that it does not affect the structural integrity of the part.

JUMPSPORT IS NOT RESPONSIBLE OR LIABLE FOR INDIRECT, SPECIAL, OR CONSEQUENTIAL DAMAGES ARISING OUT OF OR IN CONNECTION WITH THE USE OR PERFORMANCE OF THE PRODUCT OR OTHER DAMAGES WITH RESPECT TO ANY LOSS, INCLUDING BUT NOT LIMITED TO ECONOMIC LOSS, LOSS OF PROPERTY, LOSS OF REVENUE OR PROFITS, LOSS OF ENJOYMENT OR USE, COST OF REMOVAL, INSTALLATION OR OTHER CONSEQUENTIAL DAMAGES. SOME STATES DO NOT ALLOW THE EXCLUSION OR LIMITATION OF INCIDENTAL OR CONSEQUENTIAL DAMAGES. ACCORDINGLY, THE ABOVE LIMITATION MAY NOT APPLY TO YOU.

THE WARRANTY EXTENDED HEREUNDER IS IN LIEU OF ALL OTHER WARRANTIES AND ANY IMPLIED WARRANTY OF MERCHANTABILITY OR FITNESS FOR A PARTICULAR PURPOSE IS LIMITED IN ITS SCOPE AND DURATION TO THE TERMS SET FORTH HEREIN. SOME STATES DO NOT ALLOW LIMITATIONS ON HOW LONG AN IMPLIED WARRANTY LASTS. ACCORDINGLY, THE ABOVE LIMITATION MAY NOT APPLY TO YOU.

How to get a defective part replaced:

- 1) Call the JumpSport Customer Service department at 408-213-2551 to obtain a Return Authorization number. All returns must be pre-authorized.
- 2) Send the part(s) to the designated Service Center, along with a copy of your original sales receipt and a brief written description of the problem, including how it occurred. You must pay freight and insurance to return the part to JumpSport. At JumpSport's sole discretion, we may ask you to send photographs in addition to or in lieu of returning the part.
- 3) After inspecting the returned part(s), JumpSport will make a final determination whether the part is covered by this warranty. We reserve the right to examine photographs or physical evidence concerning parts claimed to be defective prior to making a final determination concerning the claim. A repaired or replacement part will be returned to you. Please allow 3 to 4 weeks for delivery.

This warranty gives you specific legal rights. You may also have other rights which vary from state to state.

JumpSport, Inc.
2055 South 7th Street, Suite A
San Jose, CA 95112

408-213-2551

<http://www.jumpsport.com>