



Dossena & C. S.n.c.

Dossena & C. di Barbatì Agostino & C.- 26824 Cavenago D'Adda (LO) Via F.Barbarossa - Italy
Tel: +39.371.44971 - Fax: +39.371.70202 - Email: dossena@dossena.it - www.dossena.it



User's manual

Threephase electrical multimeter Type Multiver 3DM / 3QM

MV3DM / MV3QM

- 1- Key to enter in configuration menu
- 2- Multifunction key: confirmation and save configuration data, select autoscroll pages
- 3- Scroll key pages and planning default parameter
- 4- Admittance cap for update

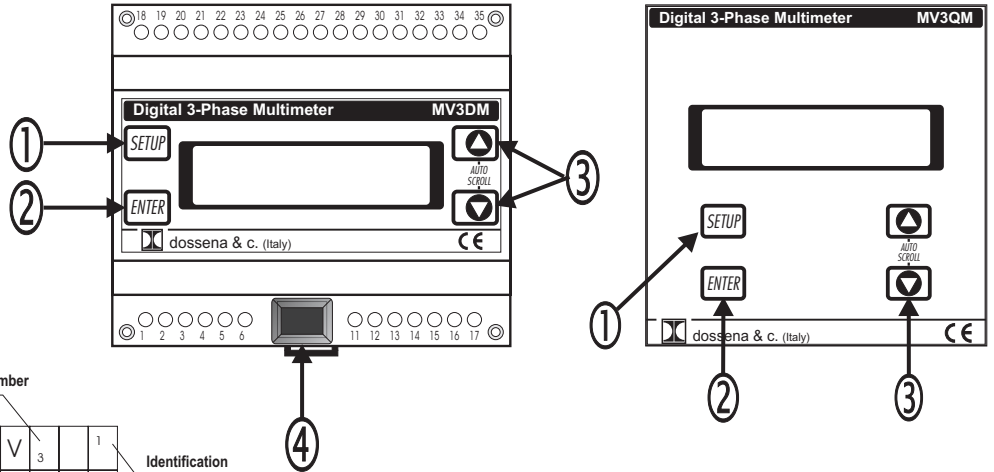

Value measured	Multiplying measure unit	Identification measurement and measure unit	Phase number	Identification page : 1, 2, ..
	k	V	1	
9	9			
9	9	9	2	
9	9	9		
9	9	9	3	
9	9	9		
				1

TECHNICAL CHARACTERISTICS

Supply voltage	115/230V (+15 -20)% 50/60 Hz
Absorption	max 5 VA
Input Voltage	Nominal 440Vac Max 600 Vrms phase phase 750 Vrms for 60sec./ 900Vrms for 1 sec.
Input Current	In = 5A from CT
Overload	1.2 In permanent 10 In for 60 sec. 50 In for 1 sec.
Insulation	3.3 kV 50 Hz for 60 sec. 4kV 1.2 / 50 μs
Working temperature	0 ÷ 50 °C
Storage temperature	-20 ÷ +70 °C
Display	Display LCD 2x16 with backlight
Protection degree	Frontal IP52 Case IP20
Terminals	Max section of the conductor 2,5 mmq.
Terminals input current	Max section of the conductor 4 mmq.
Weight	450 g.

OVERALL DIMENSIONS

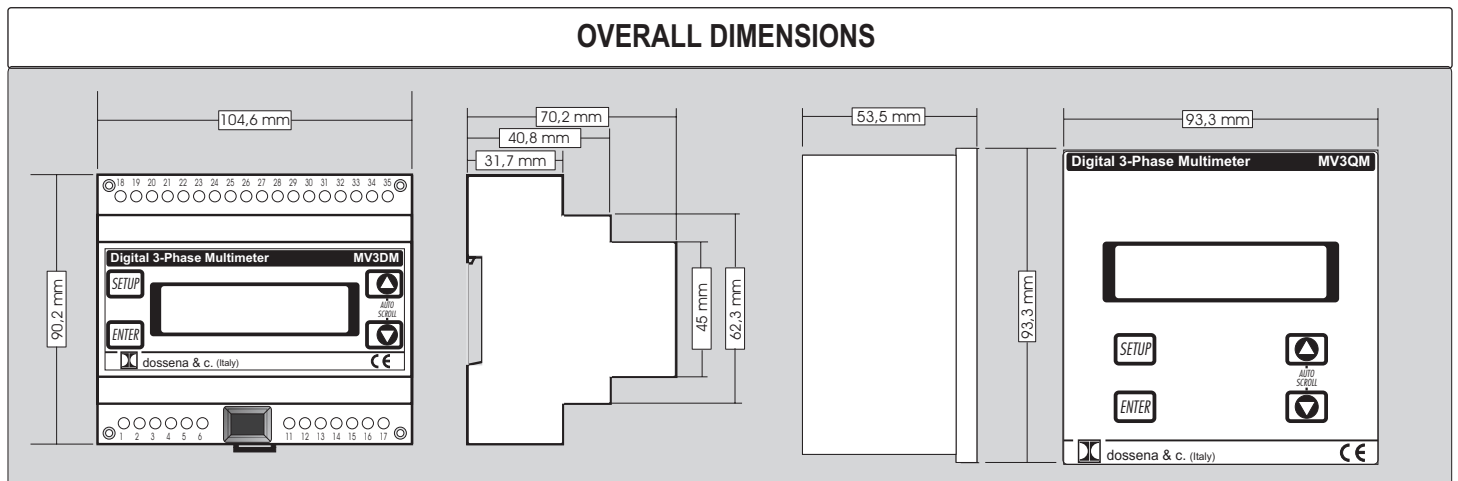

GENERAL DESCRIPTION

Three-phase multimeter , type MV3DM (DIN rail execution) and/or MV3QM (panel mounting execution 96 x 96 mm.) are measurement electrical instruments, able to measure and visualize the main electrical parameters of each phase as well as of the full 3-phase system (with or without neutral wire).

SAFETY CAUTIONS

Carefully follow the installation instructions (see next points)

Pay attention to connect the instrument without power.

Connection and installation operations must be in conformity with normal security procedures.

AUXILIARY SUPPLY

Before connecting the instrument to the aux. supply , check that the available aux. voltage is included in the range of acceptable voltage values, in the manual described.

Protect the instrument with a fuse of 0.1 A.

VOLTAGE INPUTS

The instrument can work up to a maximum voltage of 600V (phase to phase); over 440V , use Voltage Transformers (VT' s).

For the connections , follow the diagrams shown in the manual respecting the phase sequences.

Using Voltage Trasformer respect their input/ouput polarity.

CURRENT INPUTS

The instrument can accept input current values till 5A from Current Transformers (CT's). The connections must be in conformity with insertion diagrams, respecting the phases sequences, and the input/output polarity of the current transformers. It's possible to connect directly the instrument without CT 's ; these inputs are insulated from the circuit.

Pay attention that the current value doesn't exceed the declared value.

ATTENTION : short-circuit the secondary winding of the CT's , before disconnecting the current inputs of the instrument.

PAGES VISUALIZATION

The instrument visualizes the following measures , devided in 13 pages:

- (1) $V_1 / V_2 / V_3$
- (2) $V_{1-2} / V_{2-3} / V_{1-3}$
- (3) $I_1 / I_2 / I_3$
- (4) $PF_1 / PF_2 / PF_3$
- (5) $VA_1 / VA_2 / VA_3$
- (6) $W_1 / W_2 / W_3$
- (7) $VAR_1 / VAR_2 / VAR_3$
- (8) $\Sigma V / \Sigma I / \Sigma PF$
- (9) $\Sigma VA / \Sigma W / \Sigma VAR$
- (10) Hz
- (11) VARh / Wh
- (12) peak values of $\Sigma W - \Sigma Var - \Sigma I$
- (13) peak values of $I_1 I_2 I_3$

These parameters are always measured , even if they are not displayed . The values are calculated on 4 quadrants . It means that the power can be negative .

There are 3 insertion modes : single phase 4 wires and 3 wires . In three wires the measurements are right only in case of there is not return current on the neutral (equilibrated load) .

INSERTION SYSTEM

Insertion on three phase system without neutral

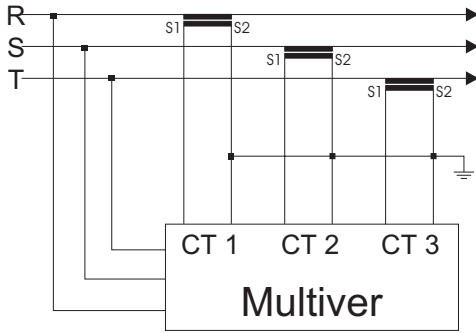

Insertion on three phase system with neutral

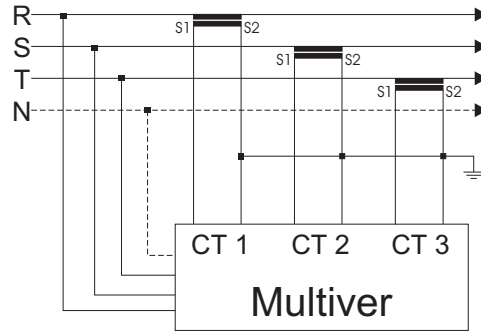

**Insertion on three phase system
ARON INSERTION**

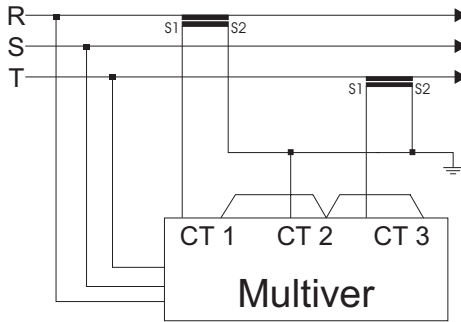

**Insertion on three phase system through
Current and Voltage Transformers**

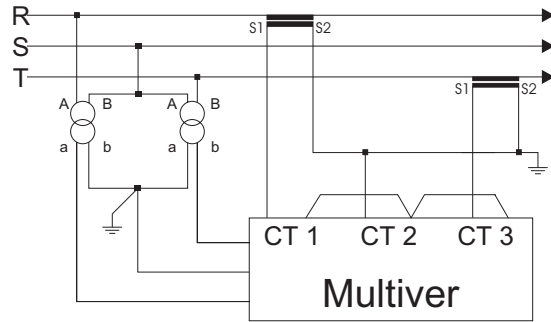

WIRING DIAGRAM

MULTIVER 3DM

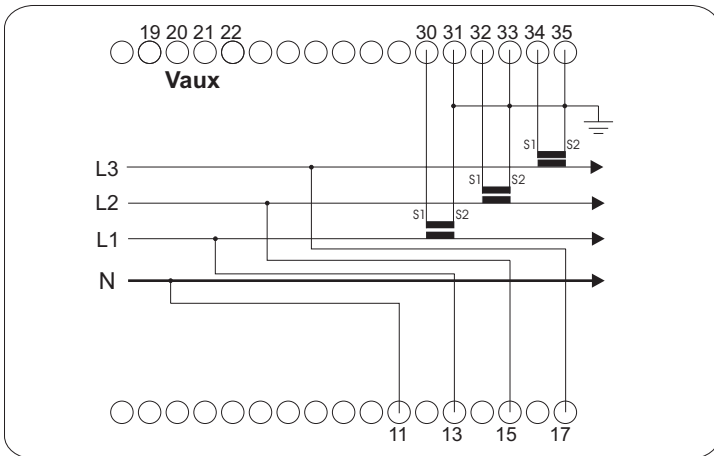

MULTIVER 3QM

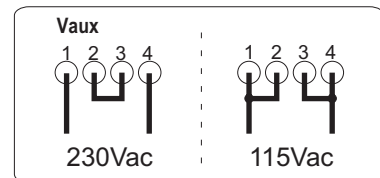
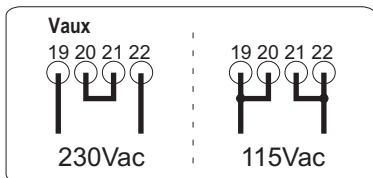
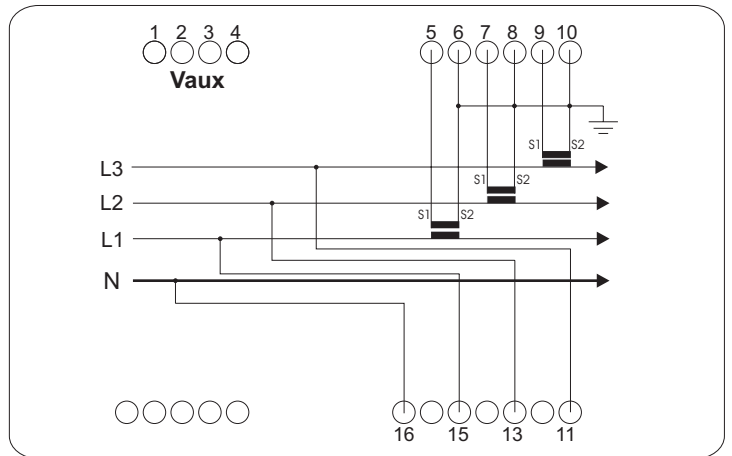

SET UP

Before using the instrument, it's necessary set the main parameters to work correctly.

Configuration operation cannot be executed if the setted parameters are the same of those presetted. The user can set the following parameters :

- Password : activation and modification
- VT's ratio
- CT's ratio
- Reset Energy Counter

To enter in to configuration modality , keep pressed **SETUP** key for about 3 seconds .

The first line of the display shows the name of the parameter to be changed , the second the relevant value (flashing).

With **SETUP** and **ENTER** keys is possible scroll up or down the different menus to set.

Keeping pressed \blacktriangle or \blacktriangledown , the flashing value is incremented or decremented. Once reached the end scale the counting restart from the minimum value. The increment / decrement is by unit pressing shortly the keys. Keeping pressed \blacktriangle or \blacktriangledown keys after 10 increments, the step goes to 10. So that the amount less significant remains equal to that initial. After other 10 increments, the step goes to 100.

Press **ENTER** to save the modifications or **SETUP** to cancel the operations .

Press again the **ENTER** key for 3 seconds to escape from the configuration menu saving all setted parameters and go back to the normal working, or press **SETUP** key for 3 seconds to escape from the configuration menu without saving parameters and go back to the normal working. After about 30 seconds without operation the instrument automatically goes out from the configuration menu without saving the parameters.

Energy counter reset

Starting from the normal working condition keep pressed **SETUP** key to enter in configuration menu. Press the **SETUP** or **ENTER** keys to visualize the menu for Energy Counter Reset .

The word "NO" is flashing : press keys \blacktriangle or \blacktriangledown to change from "not" (NO) to "yes" (SI) and viceversa. The configuration menu is the following:

R	E	S	E	T		E	N	E	R	G	I	A	:			²
A	z	z	e	r	a	r	e		?							N O

To confirm Energy Reset, go out from configuration menu pressing **ENTER**.

Peak values reset

Starting from manual working condition keep pressed **SETUP** key for 1 second.

This operation reset pages 12 - 13 for peaks values ($\Sigma W - \Sigma Var - \Sigma I - I_1 I_2 I_3$)

Voltage transformer ratio

This menu allows to set the value of Voltage Transducers connected upstream voltage inputs. If the inputs voltage are direct (without transducer) this value has to be 1 (default). Viceversa set the ratio between primary voltage and secondary of VT (usually 100V).

Maximum value to set is 1000, which corresponding to maximum voltage upstream the transducer of 100 kV. Configuration menu of VT ratio is the following:

R	A	P	P	O	R	T	O		T	V	:					³
P	r	i	m	/	S	e	c		=							1

Current transformer ratio

Maximum value to set is 2000. This value allows to measure a maximum current of 10000A, using a standard CT (x../5). The configuration menu of CT is the following :

R	A	P	P	O	R	T	O		T	A	:					⁴
P	r	i	m	/	S	e	c		=							1

Password: ACTIVATION and MODIFICATION

By protection password is possible to avoid change or reset of energy count. It is a four digit code set to 9999. The user can see the digit while he is writing. Entering for the first time in configuration menu the following write is viewed :

P	A	S	S	W	O	R	D	:									1
I	N	S	E	R	I	R	E	-	-	>							0

For password insertion press ▼ key, digits 9999 are viewed, press ENTER key one time for acceptance, the following write is viewed :

P	A	S	S	W	O	R	D	:									1
									A	C	C	E	T	T	A	T	A

Then, automatically the instrument views abilitation password:

P	A	S	S	W	O	R	D	:									1
A	b	i	l	i	t	a	t	a	=							S	I

Press the keys ▲ or ▼ to select one of the following alternatives:

- **NO** the password is not activated. It means that entering again in confirmation menu this operation start again from the beginning
- **SI** the password is activated. The user can personalize the number and the menu viewed is the following :

P	A	S	S	W	O	R	D	:									1
I	N	S	E	R	I	R	E	-	-	>							0

To inset the password , use the ▲ or ▼ keys to increment or decrement the digit. Press ENTER to confirm the password, the menu viewed is following:

P	A	S	S	W	O	R	D	:									1
A	B	I	L	I	T	A	T	A	=								0

Press ENTER to confirm the password; the instrument goes back to the page for the password activation, press the ENTER or SETUP keys to scroll the configuration menues or pressing ENTER key for 3 seconds to save the parameters and return the normal working.. At this point the password is activated. It mean that enter again in confirmation menu is necessary insert tha correct password for parameters modification; if the password is wrong, press ENTER key to view:

P	A	S	S	W	O	R	D	:									1
										E	R	R	A	T	A		

Press ENTER key or automatically after about 5 seconds, the instrument goes back to the page for the password insertion. The user can insert again the correct

P	A	S	S	W	O	R	D	:									1
R	E	G	O	L	A	Z	.		I	N	I	B	I	T	E		

By SETUP or ENTER keys select other menus but pressing ▲ or ▼ you can not modify the setted parameters. Press SETUP or ENTER keys for 3seconds the to go back to the normal working .

DEFAULT PARAMETERS

The configuration parameters are pre-set by the Manufacturing Firm so all the instruments have the same configuration. The default values are:

Ratio VT	1
Ratio CT	1
Password	Disctivated

Energy

The instrument measure the active and reactive energy (Wh and VARh). Energy measurement in co-generation plants are not allowed (supply energy towards supplier company) .In case of negative active and reactive energy , the two counters don't increment the value.

PEAK VALUE

The Multiver can memory the peak values of following measurement parameter:

A	B
Measurement in real time	Peak value recording

If $A \leq B \rightarrow$ any action

If $A > B \rightarrow$ value A is copied in B

The graphic represents the function :



AUTOSCROLL

When ON for the first time no any autoscroll page is activated; pressing simultaneously \blacktriangle and \blacktriangledown keys, the autoscroll is activated for all pages and they are viewed regularly each 3 seconds. The user can choice the page to visualize.Press and keeping pressed ENTER key to see the following message:

		V	1	2			V	2	3			V	1	3	2
A	u	t	o	s	c	r	o	l	l				S	I	

Press simultaneously \blacktriangle and \blacktriangledown keys, all autoscroll are actvated

Press and keeping pressed ENTER key to see the following:

		V	1	2			V	2	3			V	1	3	2
A	u	t	o	s	c	r	o	l	l				N	O	

To change from YES to NO and viceversa press one key and leave again ENTER key . Repeat the sequence from point 2 , for further pages . activation, press simultaneously \blacktriangle and \blacktriangledown keys to start autoscroll function.

During the autoscroll operation, under the number of the page flashing a rectangle (1 x 4 pixel) .

To go back to normal visualization press one of the 4 keys .

ACCURACY AND UNCERTAINTY

Parameter	Range	Precision	Uncertainty
Voltage	10 ÷ 440Vrms	0,50%	± 1digit
Current	0,02 ÷ 5 A	0,50%	± 1digit
Frequency	45 ÷ 65 Hz	0,05%	2 x 10-2

For the calculated measurement, the error depends from those primary measurements. If current or voltage transformer are inserted, consider the accuracy of the same to value accuracy error on primary measurements.

INTERNATIONAL STANDARD

ELETTROMAGNETIC COMPATIBILITY

CEI EN 50081-2 / CEI IEC 1000-4-2 / CEI IEC 1000-4-4

CEI EN 50082-2 / CEI EN 61000-4-5 / CEI EN 61000-4-1

LOW VOLTAGE

CEI EN 61010-1

CEI EN 60529

APPENDIX A

<i>Trouble shooting</i>	<i>Problem solver</i>
The Multiver does not turn on when power supplied	Check the right shut of screws and connection wires
The Multiver does not visualize the voltage / current measures	Check the right shut of screws and connection wires
The Multiver is in the first page but isn't starting	Check the right power supply
The Multiver visualize negative active power whith a load connected	Turn the secondary wires of current trasformer for the right measures
The Multiver does not visualize right measure of voltage / current	Check on menu the right CT and VT configuration

INDEX

Presentation.....	pag. 1
Technical characteristics.....	pag. 1
Dimensions.....	pag. 1
General description.....	pag. 2
Safety cautions.....	pag. 2
Auxiliary supply.....	pag. 2
Voltage inputs.....	pag. 2
Current inputs.....	pag. 2
Page visualization.....	pag. 2
Insertion system.....	pag. 3
Wiring diagram.....	pag. 3
Set up.....	pagg. 4 / 5 / 6
Energy counter reset.....	pag. 4
Voltage trasformer ratio.....	pag. 4
Current trasformer ratio.....	pag. 4
Peak value reset.....	pag. 4
Password : activation and modification.....	pag. 5
Default parameters.....	pag. 5
Energy.....	pag. 6
Autoscroll.....	pag. 6
Accuracy.....	pag. 6
International standards.....	pag. 6
Appendix A. : Trouble shooting	pag. 7

Le dimensioni e le caratteristiche tecniche non sono impegnative e sono modificabili senza preavvisi da parte dell' azienda costruttrice.
Dimension and technical characteristics are not binding and they can be modified without notice from the manufacturer.



Dossena & C.

Dossena & C. di Barbati Agostino & C. 26824 Cavenago D'Adda (Lo), via F.Barbarossa Italy,
Tel. +39(0)371.44971, fax +39(0)371.70202 - Internet: <http://www.dossena.it> - Email: dossena@dossena.it

Rev.00 MU 810 17/07/01