

Serial No.	H-V037-E-6
------------	------------

PDCPD Butterfly Valve

700mm - 1200mm (28" - 48")

User's Manual

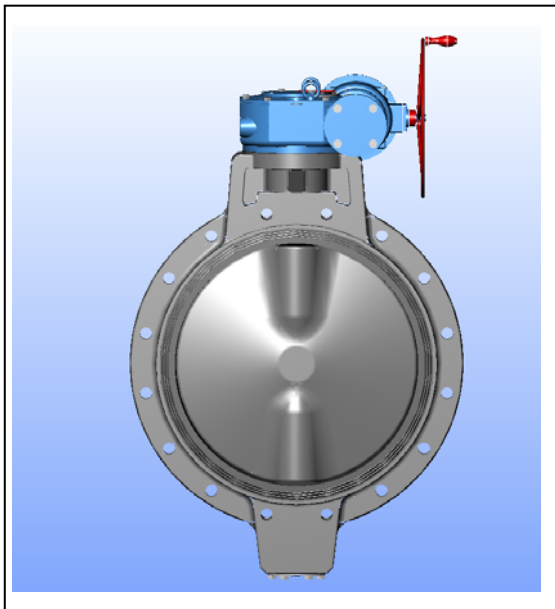



Contents



- (1) Be sure to read the following warranty clauses of our product 1
- (2) General operating instructions 2
- (3) General instructions for transportation, unpacking and storage 3
- (4) Name of parts 4
- (5) Working pressure and temperature 6
- (6) Installation procedure 7
- (7) Support setting procedure 11
- (8) Operating procedure 12
- (9) General instructions for fluid flowing 12
- (10) Inspection items 12
- (11) Troubleshooting 13
- (12) Handling of residual and waste materials 13

This user's guide contains information important to the proper installation, maintenance and safe use of an ASAHI AV Product. Please store this manual in an easily accessible location.

<Warning & Caution Signs>

 Warning	This symbol reminds the user to take caution due to the potential for serious injury or death.
 Caution	This symbol reminds the user to take caution due to the potential for damage to the valve if used in such a manner.



<Prohibited & Mandatory Action Signs>



	Prohibited: When operating the valve, this symbol indicates an action that should not be taken.
	Mandatory action: When operating the valve, this symbol indicates mandatory actions that must be adhered to.

(1) Be sure to read the following warranty clauses of our product

- Always observe the specifications of and the precautions and instructions on using our product.
- We always strive to improve product quality and reliability, but cannot guarantee perfection. Therefore, should you intend to use this product with any equipment or machinery that may pose the risk of serious or even fatal injury, or property damage, ensure an appropriate safety design or take other measures with sufficient consideration given to possible problems. We shall assume no responsibility for any inconvenience stemming from any action on your part without our written consent in the form of specifications or other documented approval.
- The related technical documents, operation manuals, and other documentation prescribe precautions on selecting, constructing, installing, operating, maintaining, and servicing our products. For details, consult with our nearest distributor or agent.
- Our product warranty extends for one and a half years after the product is shipped from our factory or one year after the product is installed, whichever comes first. Any product abnormality that occurs during the warranty period or which is reported to us will be investigated immediately to identify its cause. Should our product be deemed defective, we shall assume the responsibility to repair or replace it free of charge.
- Any repair or replacement needed after the warranty period ends shall be charged to the customer.
- The warranty does not cover the following cases:
 - (1) Using our product under any condition not covered by our defined scope of warranty.
 - (2) Failure to observe our defined precautions or instructions regarding the construction, installation, handling, maintenance, or servicing of our product.
 - (3) Any inconvenience caused by any product other than ours.
 - (4) Remodeling or otherwise modifying our product by anyone other than us.
 - (5) Using any part of our product for anything other than the intended use of the product.
 - (6) Any abnormality that occurs due to a natural disaster, accident, or other incident not stemming from something inside our product.

(2) General operating instructions

- 

- Using a positive-pressure gas with our plastic piping may pose a dangerous condition due to the repellent force particular to compressible fluids even when the gas is under similar pressures used for liquids. Therefore, be sure to take the necessary safety precautions such as covering the piping with protective material. For inquiries, please contact us. For conducting a leak test on newly installed piping, be sure to check for leaks under water pressure. If absolutely necessary to use a gas in testing, please consult your nearest service station beforehand.
- 

- Do not step on or apply excessive weight on valve. (It can be damaged.)
- 

- Do not use the valve in conditions where the fluid may have crystallized.
(The valve will not operate properly.)
- 

- Keep the valve away from excessive heat or fire. (It can be damaged, or destroyed.)
- Always operate the valve within the pressure vs. temperature range.
(The valve can be damaged or deformed by operating beyond the allowable range.)
- Allow sufficient space for maintenance and inspection.
- Select a valve material that is compatible with the media. For chemical resistance information, refer to “CHEMICAL RESISTANCE ON ASAHI AV VALVE”.
(Some chemicals may damage incompatible valve materials.)
- Keep the valve out of direct sunlight, water and dust. Use cover to shield the valve.
(The valve will not operate properly.)
- Perform periodic maintenance.
(Leakage may develop due to temperature changes or periods of prolonged storage, rest, or operation.)

(3) General instructions for transportation, unpacking and storage



Warning



Caution

- When suspending and supporting a valve, take care and do not stand under a suspended valve.
- This valve is not designed to handle impacts of any kind. Avoid throwing or dropping the valve.
- Avoid scratching the valve with any sharp object.
- Do not over-stack cardboard shipping boxes. Excessively stacked packages may collapse.
- Avoid contact with any coal tar creosote, insecticides, vermicides or paint.
(These chemicals may cause damage to the valve.)
- When transporting a valve, do not carry it by the handle.
- Store products in their corrugated cardboard boxes. Avoid exposing products to direct sunlight, and store them indoors (at room temperature). Also avoid storing products in areas with excessive temperatures. (Corrugated cardboard packages become weaker as they become wet with water or other liquid. Take care in storage and handling.)
- After unpacking the products, check that they are defect-free and meet the specifications.
- Once you have taken the product out of its packaging or crate, clean the inside of the valve with a clean piece of cloth.

(4) Name of parts

Nominal size: 700mm – 1000mm (28” – 40”)

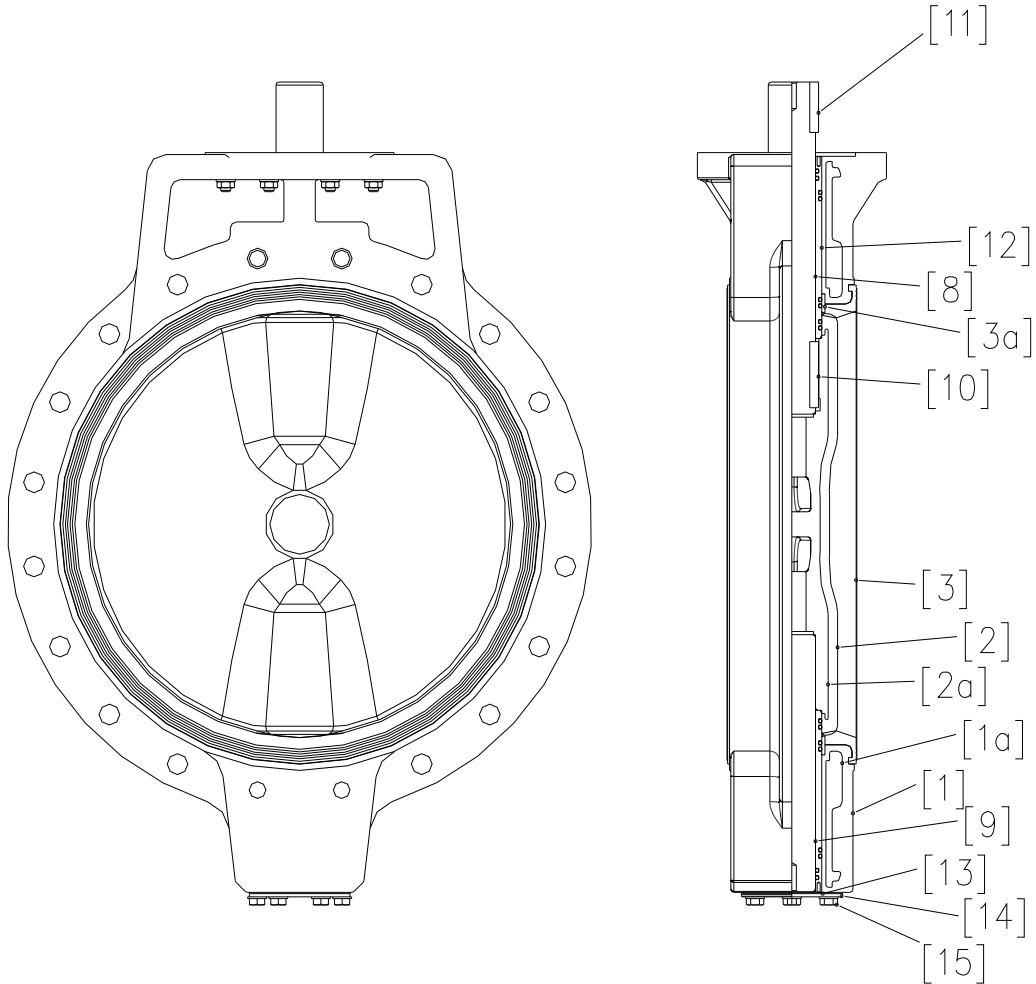

No.	DESCRIPTION	No.	DESCRIPTION
[1]	Body	[9]	Stem (B)
[1a]	Inserted Metal of Body	[10]	Key (A)
[2]	Disc	[11]	Key (B)
[2a]	Inserted Metal of Disc	[12]	Bush
[3]	Seat	[13]	Gasket (A)
[3a]	Stabilization Ring	[14]	Stem Holder (A)
[8]	Stem (A)	[15]	Bolt (A)

Nominal size: 1100mm – 1200mm (44” – 48”)

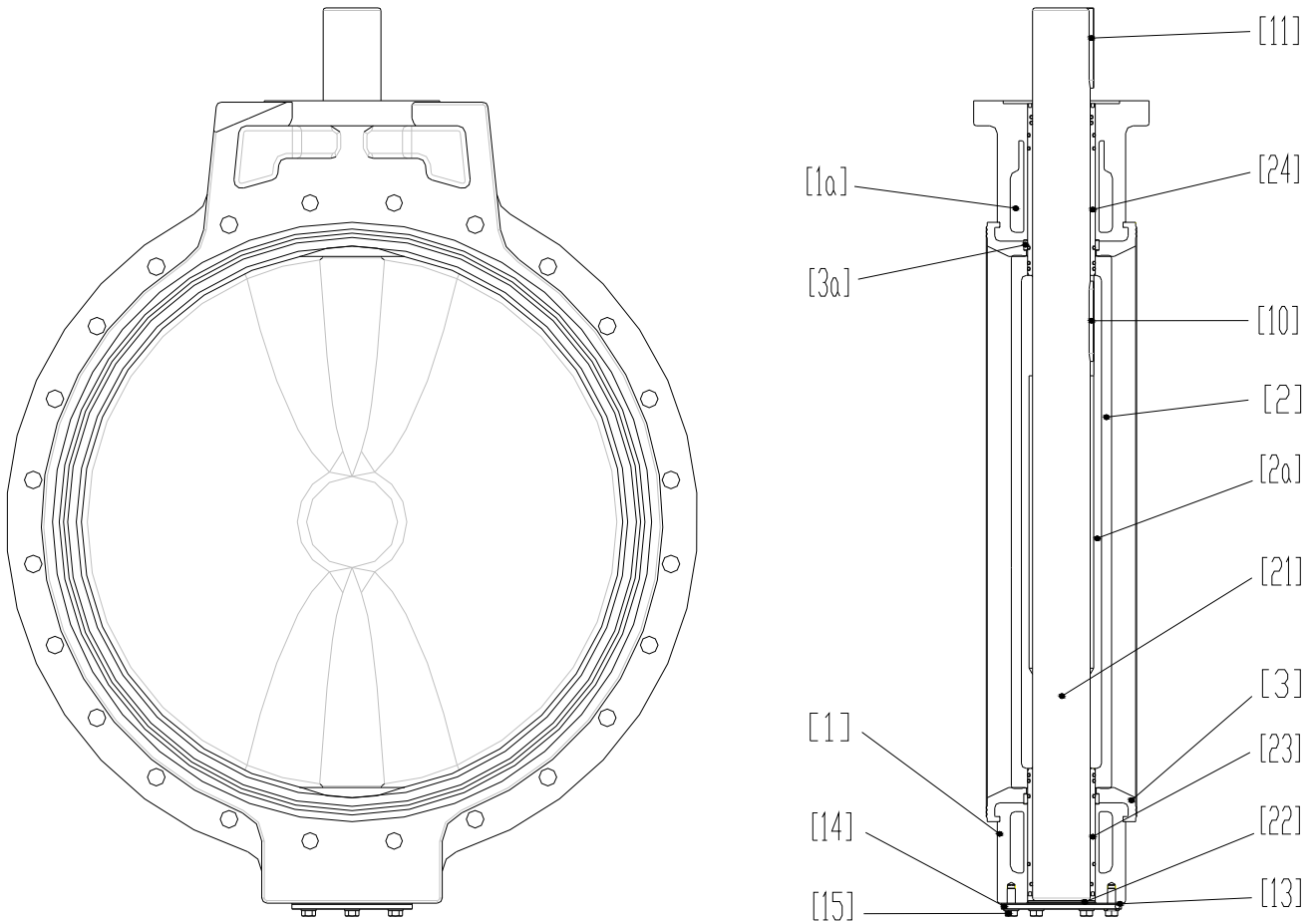

No.	DESCRIPTION	No.	DESCRIPTION
[1]	Body	[13]	Gasket (A)
[1a]	Inserted Metal of Body	[14]	Stem Holder (A)
[2]	Disc	[15]	Bolt (A)
[2a]	Inserted Metal of Disc	[21]	Stem
[3]	Seat	[22]	Thrust
[3a]	Stabilization Ring	[23]	Bush (A)
[10]	Key (A)	[24]	Bush (B)
[11]	Key (B)		

(5) Working pressure vs. temperature

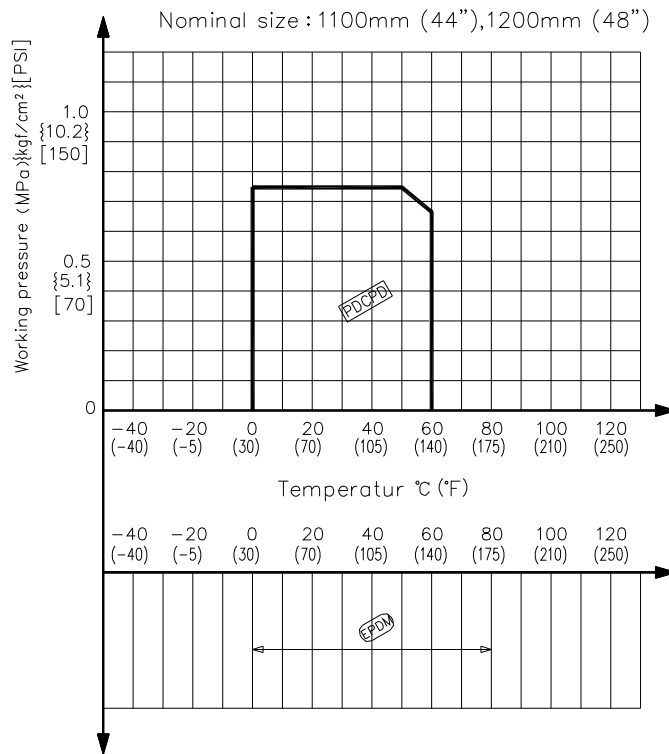
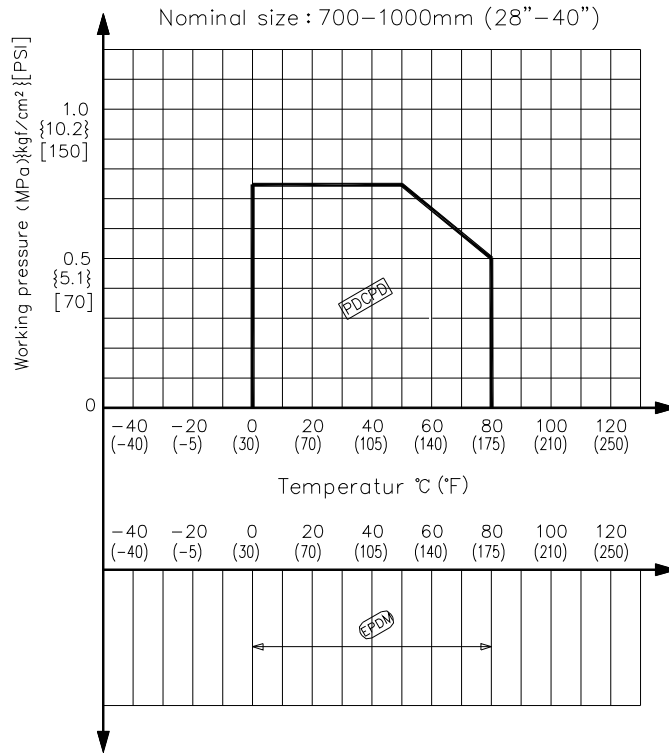

(6) Installation procedure



Warning

- When suspending and supporting a valve, take care and do not stand under a suspended valve.



- Be sure to conduct a safety check on all hand and power tools to be used before beginning work.
 - Wear protective gloves and safety goggles as fluid remain in the valve even if the pipeline is empty.
 (You may be injured.)



Caution

- When installing a pipe support by means of a U-band or something similar, take care not to over-tighten.
 (Excessive force may damage the pipe.)
 - Do not install the valve with the disc fully closed. (The disc may pinch into the seat, resulting in a high operating torque and preventing the valve from operating properly.)
 - When installing pipes and valves, ensure that they are not subjected to tension, compression, bending, impact, or other excessive stress.
 - Use flat faced flanges for connection to AV Valves.
 - Ensure that the mating flanges are of the same standards.
 - The gasket is unnecessary. (The seat carries out the role of the gasket.)

- The valve disc is in the position indicated by solid lines in figure to the right prior to shipment from the factory. If the valve is opened or closed after unpacking, it must be reset in this position before installation. Failure to do so will result in damage to the surface of the valve seat during handling and installation.
 - Care must be used during piping installation to ensure that the pipes or flanges are properly aligned so that the valve disc does not contact them in any setting. Misalignment as in figure below will result in damage to the valve.

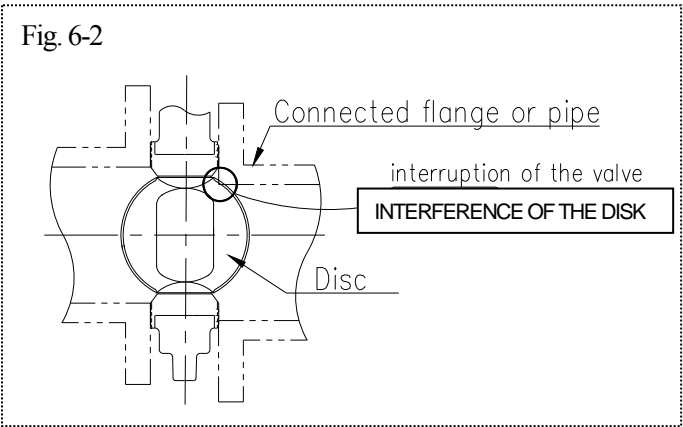
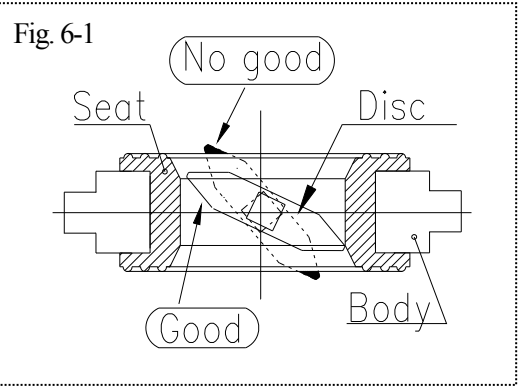

In case of an abutting thick walled flange and pipe, shave the flange or the pipe inner diameter in order to avoid contact of pipe and disc. If the inside diameter of the connecting pipe is larger than dimension D below, shaving is not necessary.

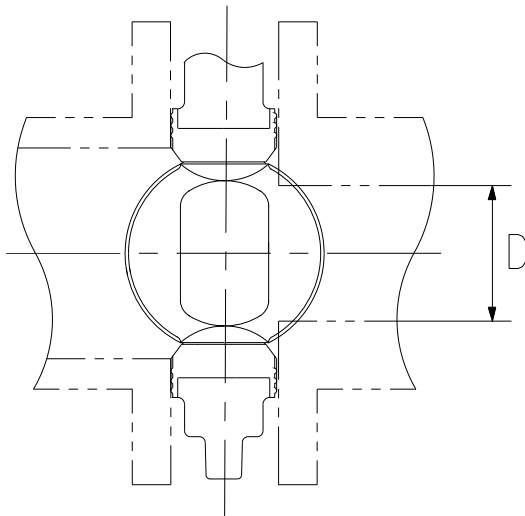

Nominal Size	Diameter D
700mm (28")	649mm (25.55")
800mm (32")	743mm (29.25")
900mm (36")	848mm (33.39")
1000mm (40")	936mm (36.85")
1100mm (44")	1054mm (41.50")
1200mm (48")	1136mm (44.72")

1) Set the short pipes.

Set the short pipes with suitable stands so that the center of the valve in the upright position aligns with that of the short pipe. Using a cloth, wipe foreign matter away from the flange surfaces of the short pipes.

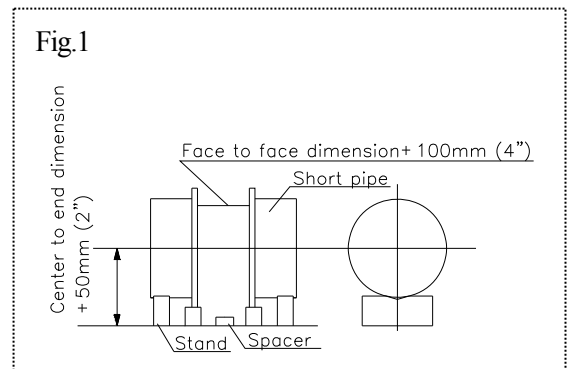

- 2) Stand the valve upright.

Wind the nylon sling around the head part of the body and gradually raise it up. After standing the valve upright, wipe foreign matter away from the seat with a cloth.

 - Support the valve up by looping a belt around the gearbox. Like Fig 2. The eyebolt in the gearbox is designed to support the weight of gearbox (about 500kg), so avoid lifting up the whole valve with the eyebolt. Use it just as a support to stand the valve upright.

Fig.2



- 3) Lower the valve gradually between the short pipes onto the spacer. Lower the valve carefully without damaging the flange surfaces of short pipes
The required face to face dimension of each valve size is shown below.
Make sure that the valve is slightly closed.

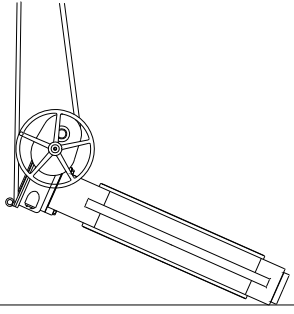
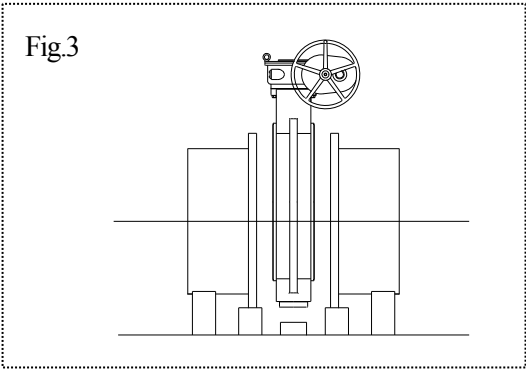

Unit; mm (inch)

Nom. Size	mm (inch)	Dimension	mm (inch)
700mm	(28")	206mm	(8.11")
800mm	(32")	240mm	(9.45")
900mm	(36")	240mm	(9.45")
1000mm	(40")	300mm	(11.81")
1100mm	(44")	300mm	(11.81")
1200mm	(48")	350mm	(13.78")

- 4) Connect the valve loosely to one of the short pipes. Match the bolt hole of the short pipe with that of the valve, and put four stud bolts into the inserted metal parts (part 1a), then tighten nuts lightly by hand.

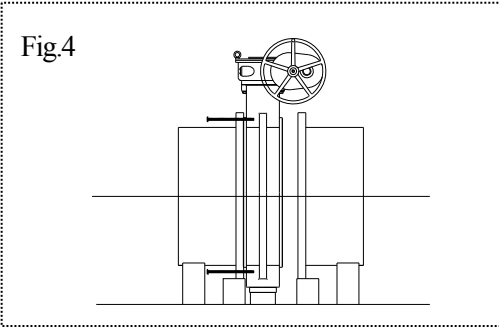

- 5) Set the second short pipe with the valve.
Using the nylon sling, loop the short pipe and tighten nuts using the same procedure as step 4).

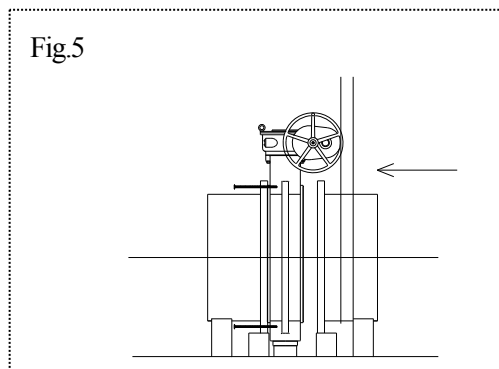

- 6) Put the bolts through the full bolt holes and plumb in.
Move the pipe gradually to match holes one another, and set nuts.
*Tighten the bolt-nuts of the valve and the flange in the full bolt holes at first, and then tighten the bolt-nuts on the inserted metal parts.

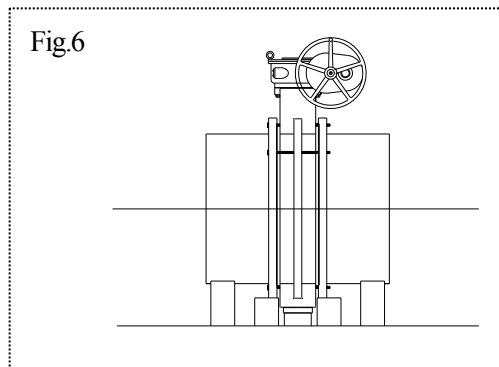

- 7) Tighten up the nuts according to the tightening torque values listed below
Tighten the nuts in a diagonal manner.
All penetrated bolts should be tightened first, and the inserted metal parts should be tightened after.

Nom. Size mm(inch)	Bolt tightening torque N·m(kgf·cm)
700, 800mm (28", 34")	130 (1,300)
900, 1000mm (36", 40")	170 (1,700)
1100mm (44")	200 (2,000)
1200mm (48")	220 (2,200)

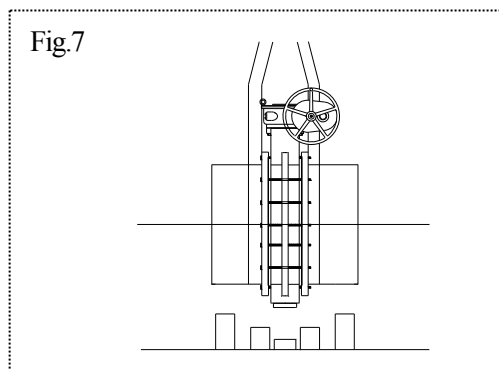

- 8) Using the nylon sling, lift up around the flange sides of both short pipes to set in the required position.
Hook a wire through the eyebolt in order to stabilize the valve.

(7) Support setting procedure

Necessary items

- Spanner wrench
- U-type clamp (with bolt)
- Rubber sheet

- Do not subject valve pump vibrations. (The valve may be damaged.)

Caution

- Set the valve support. (The valve may be damaged because the actuator is heavy.)

Horizontal installation

Set the stand under the valve.

Spread the rubber sheet on the pipe and secure pipe with U-type clamp.

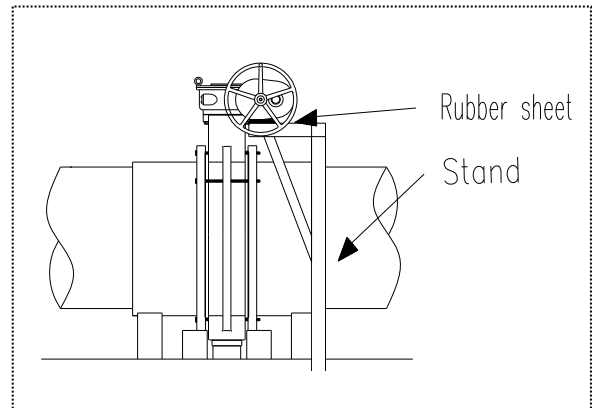



Vertical installation

Spread the rubber sheet under the gearbox, and fix it with the stand.

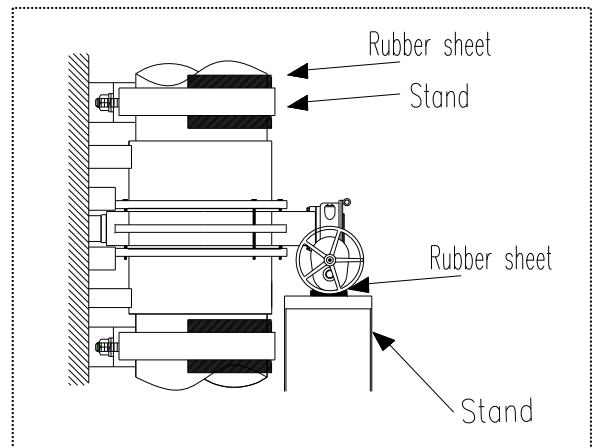
Spread the rubber sheet on the pipe and secure pipe with U-type clamp.



(8) Operating procedure

  - Do not use the valve to fluid containing slurry. (The valve will not operate properly.)

Caution  - The installed valve must never be opened or closed when foreign matter such as sand is present in the pipeline.

- Do not exert excessive force in closing the valve.
- When operating the handle, be sure to do so with your hand. (Using a tool may damage the handle.)

Turn the handle gently to open or close.
 Check the travel indicator on the top of the gearbox, and turn the handle.



Right turn (Clockwise) → Shut direction

Left turn (Counter clockwise) → Open direction

(9) General instructions for fluid flowing

- 1) Make sure that any foreign matter is not in the pipe, which may damage the valve seat before fluid flowing. Open the valve fully when the fluid starts flowing.
- 2) Although the sealing adjustment of disc is already adjusted, if the valve leaks during operation, loosen the stopper bolt in the actuator and find the volume of tightening.

(10) Inspection items

  - Perform periodic maintenance. (Leakage may develop due to temperature changes or over periods of prolonged storage, rest or operation.)



○ Inspect the follow items;

(1)	Check for any flaw, crack, or deformation on the outside.
(2)	Check whether fluid leaks to the outside.
(3)	Check whether there are protrusion or retirement of seat.
(4)	Check the smoothness of handle operation.

(11) Troubleshooting

Problem	Cause	Treatment
The valve does not operate smoothly.	The protrusion of the seat. The uneven or excessive tightening of the bolt.	Loosen the bolt and adjust.
Fluid is not stopped in the full closed position.	The stopper is not adjusted properly.	Adjuster the stopper.
	The seat is damaged or worn.	Replace the seat.
	Foreign matter is in the valve.	Disassemble the valve and clean. (Refer to page 7)
	The disc is damaged or worn.	Replace the disc.
	The connecting bolts are too much tightened or tightened unevenly.	Reset the valve. (Refer to page 7)
Fluid leaks to the outside.	The seat is damaged or worn.	Replace the seat.
The handle does not work smoothly.	Foreign matter is adhered.	Reset the valve. (Refer to page 7)
	The gearbox is damaged.	Replace the gearbox.
	The connecting bolts are too much tightened.	Reset the valve. (Refer to page 7)
The valve does not operate.	The gearbox is damaged.	Repair or replace.
	The stem is damaged.	Replace the stem.

(12) Handling of residual and waste materials

  - Make sure to consult a waste treatment dealer for recommendations on the proper disposal of plastic valves. (Poisonous gas is generated when the valve is burned improperly.)

Warning

PDCPD Butterfly Valves
700mm - 1200mm (28" - 48")



Distributor

Asahi Organic Chemicals Industry's homepage

<http://www.asahi-yukizai.co.jp/en/>