



Heating and Air Conditioning

USER'S, MAINTENANCE and SERVICE INFORMATION MANUAL

SINGLE PACKAGE AIR CONDITIONER GAS/ELECTRIC

The manufacturer recommends that the "User" read all sections of this manual and keep the manual for future reference.

CONTENTS

SAFETY INFORMATION 2

SYSTEM OPERATION 2
 THERMOSTATS 2
 HOT SURFACE PILOT IGNITION
 DEVICE 2
 HEATING 2
 COOLING 3
 CIRCULATING FAN 3
 INPUT 3

**FOR YOUR SAFETY, READ BEFORE
 OPERATING** 3

WHAT TO DO IF YOU SMELL GAS 4

**START-UP INSTRUCTIONS - HEATING
 SYSTEM** 4

**SHUTDOWN INSTRUCTION - TO TURN
 OFF GAS TO APPLIANCE** 4

SECURE OWNER'S APPROVAL 5

MAINTENANCE 5
 NORMAL MAINTENANCE 5
 LUBRICATION 5
 GENERAL MAINTENANCE 5
 FILTER CARE 5
 OUTDOOR COIL 5
 BURNER 5
 TO CLEAN BURNERS 5
 COMBUSTION AIR DISCHARGE 5
 CLEANING FLUE PASSAGES AND
 HEATING ELEMENTS 6
 REGISTERS 6

TROUBLESHOOTING 6
 BEFORE CALLING A SERVICE-
 PERSON 6

REPLACEMENT PARTS 6

SOME EFFICIENCY DO'S AND DONT'S .. 6

⚠ WARNING

FIRE OR EXPLOSION HAZARD

Failure to follow safety warnings exactly could result in serious injury, death, or property damage.

- Do not store or use gasoline or other flammable vapors and liquids in the vicinity of this or any other appliance.
- WHAT TO DO IF YOU SMELL GAS:
 - Do not try to light any appliance.
 - Do not touch any electrical switch; do not use any phone in your building.
 - Leave the building immediately.
 - Immediately call your gas supplier from a neighbor's phone. Follow the gas supplier's instructions.
 - If you cannot reach your gas supplier, call the fire department.
- Installation and service must be performed by a qualified installer, service agency or the gas supplier.

Congratulations . . .

On your purchase of one of our Single Package Air Conditioning Units. This energy efficient system has been precision designed, manufactured of high quality materials and has passed many vigorous inspections and tests to ensure years of satisfactory service.

Please read this manual thoroughly. It will help you understand your system, tell you how to operate it efficiently and how to obtain the greatest measure of comfort at the lowest operating expense.

We appreciate your interest in our products and your decision to purchase our Single Package Unit. Enjoy your comfort.

SAFETY INFORMATION - FOR YOUR SAFETY

- Make sure that the furnace area is clear and free of combustible materials, gasoline and other flammable vapors and liquids.
- Be sure the furnace is free and clear of insulating material. Examine the installation of the furnace for addition of insulation. Some insulations are combustible.
- For proper operation of this furnace, air for combustion and ventilation is required. Make sure that these openings are not obstructed.
- For lighting or shutting down this furnace, refer to the lighting instructions provided adjacent to the burners and also located in this manual.
- A blocked vent roll-out switch is provided in the burner compartment. This switch is a manual reset. If the furnace fails to operate, contact a qualified service agency.
- Should the gas supply fail to shut off or if overheating occurs, shut off the gas valve to the furnace before shutting off the electrical supply. Then call a qualified service technician.

- Do not use this furnace if any part has been under water. A flood-damaged furnace is extremely dangerous. Attempts to use the furnace can result in fire or explosion. A qualified service agency should be contacted to inspect the furnace and to replace all gas controls, control system parts, electrical parts that have been wet or the furnace if deemed necessary.
- Determine the integrity of the installation regarding the flue gas vent, the return and supply air duct, the equipment is well supported and there are no signs of deterioration. The manufacturer recommends that main burner, ignition device and controls are inspected by a qualified furnace technician before each heating season.

This gas/electric, heating/cooling unit is designed for outdoor use and can be installed anywhere from grade level to the roof. Electric air conditioning in the summer and gas heating in the winter - all from a single unit.

SYSTEM OPERATION

THERMOSTATS

Set your thermostat for either heating or cooling then set it for the desired temperature. **DO NOT MOVE THE THERMOSTAT RAPIDLY ON AND OFF, OR BACK AND FORTH FROM HEAT TO**

COOL. THIS COULD DAMAGE YOUR EQUIPMENT.

Always allow at least 5 minutes between changes. Find the temperature that is most comfortable to you, and then **LEAVE YOUR THERMOSTAT ALONE.** (Exception is for night or vacation "set back" to conserve energy)

Manually moving the thermostat up or down will not speed up temperature changes in your rooms. This only causes the thermostat switch to function at your command rather than responding to room temperature.

Heat generated by devices other than the furnace may interfere with thermostat performance. Therefore, lamps, radios, television sets, etc. should not be placed near the thermostat.

HOT SURFACE PILOT IGNITION DEVICE

This unit is equipped with a hot surface pilot ignition device. The control is designed to automatically light the burner each time the thermostat "calls" for heat.

CAUTION

Do not attempt to manually light the burners. Personal injury could result.

HEATING

When the thermostat calls for HEAT, the thermostat terminal "W" is energized, the control board checks for an open pressure switch

“PS” and closed limit switches, then energizes the combustion air blower.

After combustion airflow is established, the air proving pressure switch “PS” closes, the hot surface ignitor is energized and the pilot valve opens igniting the pilot flame.

The flame rod senses a flame and de-energizes the ignitor opening the main gas valve and the main burners light.

30 seconds after the main burners light the circulating fan is energized at the heating speed.

When the thermostat is satisfied, terminal W is de-energized, de-energizing the ignition system closing the gas valve.

After a 5 second postpurge timing period, the combustion air blower is de-energized and the heat fan off timing begins.

When this field selected heat fan off timing is completed the circulating fan is de-energized.

If the limit switch “LS”, auxiliary limit switch “ALS” or the rollout switch “RS” open, the ignition system is de-energized and the gas valve closes. The combustion blower and the circulating fan are energized.

The combustion blower remains energized for the 5 second post-purge timing period if the limit switch “LS”, auxiliary limit switch “ALS” or the rollout switch “RS” contacts reset (the rollout “RS” and auxiliary limit switch “ALS” must be manually reset). The circulating fan remains energized for the selected heat delay off timing.

Normal operation of the system resumes.

WARNING

Should overheating occur, shut off the manual gas valve external to the appliance before shutting off the electrical supply.

WARNING

Flue hood surface and immediate area is designed to operate at high temperatures during the heating cycle. Special attention must be given to keep all human contact and debris away from this area.

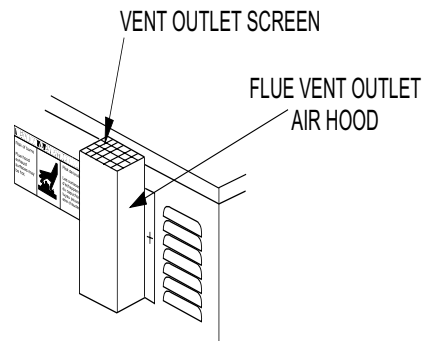

WARNING

Incorrect installation of the flue vent hood could cause personal injury or property damage.

COOLING

When the thermostat calls for “COOL”, the thermostat signals the compressor and outdoor fan to run.

After a cool fan on delay timing of 6 seconds, the circulating fan is energized at cooling speed.

When the thermostat is satisfied, the compressor and outdoor fan is de-energized.

After a cool fan off delay timing of 30 seconds the circulating fan is de-energized.

CIRCULATING FAN

When the thermostat calls for “FAN”, the thermostat terminal signals the circulating fan to run at the heat speed 2 seconds after the thermostat is energized.

If a call for “HEAT” occurs, the circulating fan continues to run at the heat speed.

If a call for “COOL” occurs, the circulating fan switches to cool speed after a 4 second delay.

When the thermostat ends the call for “FAN”, the thermostat is de-energized, de-energizing the circulating fan.

INPUT

The correct heat capacity of the furnace is regulated by the burner orifices and the gas pressure. The proper orifices are furnished but the gas pressure regulator must be adjusted by the installing serviceman or gas company. This is a “one-time” adjustment.

FOR YOUR SAFETY, READ BEFORE OPERATING

WARNING

If you do not follow these instructions exactly, a fire or explosion may result, causing property damage, personal injury or loss of life.

- A. BEFORE OPERATING, smell all around the appliance area for gas. Be sure to smell around the base of the unit because some gas is heavier than air and will settle in the area.

WHAT TO DO IF YOU SMELL GAS

- Do not try to light any appliance.
 - Do not touch any electrical switch.
 - Do not use any phone in your building.
 - Immediately call your gas supplier from a neighbor's phone. Follow the gas supplier's instructions.
 - If you cannot reach your gas supplier, call the fire department.
- A. Use only your hand to push in or turn the gas control knob. Never use tools. If the knob will not push in or turn by hand, don't try to repair it, call a qualified service technician. Force or attempted repair may result in a fire or explosion.

- B. Do not use this appliance if any part has been under water. Immediately call a qualified service technician to inspect the appliance and to replace any part of the control system and any gas control which has been under water.

START-UP INSTRUCTIONS - HEATING SYSTEM

NOTE: See General instructions for Start-up and Shutdown of your gas heating system.

1. STOP! Read the safety information.

2. Set the thermostat to the lowest setting.
3. Make sure all electrical power to the furnace is "OFF".
4. This appliance has a device which automatically lights the pilot and inturn, lights the burners.
5. Remove burner access panel by removing screws and lifting panel out.
6. Push the manual gas switch to the "OFF" position.
7. Wait five (5) minutes to clear out any gas. If you then smell gas, STOP! Follow step A in the safety information. If you don't smell gas, go to next step.
8. Push the manual gas switch to the ON position.
9. Replace the control access panel.
10. Turn on all electrical power to the appliance.
11. Set the thermostat to the desired setting.
12. If the appliance will not operate, follow the instruction "To Turn OFF Gas To Application" and call your service technician or gas supplier.

SHUTDOWN INSTRUCTION - TO TURN OFF GAS TO APPLIANCE

CAUTION

Should overheating occur, or the gas supply fail to shut off, shut off the manual gas valve to the furnace before shutting off the electrical supply.

1. Set the thermostat to the lowest setting.

2. Turn off all electrical power to the appliance if service is to be performed.
3. Remove burner access panel by removing screws and lifting panel out.
4. Push the manual gas switch to the "OFF" position.

MANUAL GAS SWITCH (SHOWN IN "OFF" POSITION)

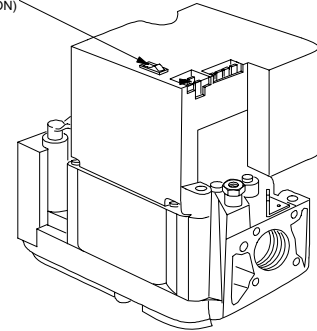

5. Replace the control access panel.

WARNING

ELECTRICAL SHOCK, FIRE OR EXPLOSION HAZARD

Failure to follow safety warnings exactly could result in dangerous operation, serious injury, death or property damage.

Improper servicing could result in dangerous operation, serious injury, death or property damage.

- Before servicing, disconnect all electrical power to furnace.
- When servicing controls, label all wires prior to disconnecting. Reconnect wires correctly.
- Verify proper operation after servicing.

SECURE OWNER'S APPROVAL

When the system is functioning properly, secure the owner's approval. Show the owner the location of all disconnect switches and the thermostat. Teach owner how to start and stop the unit and how to adjust temperature settings within the limitations of the system. Advise owner that the flue exhaust hood surface and the immediate area will experience high temperatures during the heating cycle. All unauthorized personnel and debris must be kept away from this area.

MAINTENANCE

NORMAL MAINTENANCE

WARNING

PRIOR TO ANY OF THE FOLLOWING MAINTENANCE PROCEDURES, SHUT OFF ALL POWER TO THE UNIT, TO AVOID PERSONAL INJURY.

Periodic maintenance consists of changing or cleaning filters. Under some conditions, the main burners should be cleaned.

LUBRICATION

The indoor blower motor, outdoor fan motor and venter motor are permanently lubricated and require no maintenance.

GENERAL MAINTENANCE

The manufacturer recommends that the furnace system be inspected once a year by a qualified service person.

For proper and safe operation, the gas heating section needs air for combustion and ventilation. Do not block or obstruct air openings on the unit, nor the spacing around the unit. Keep the gas heating system area clear and free of combustible materials, gasoline and other flammable vapors and liquids.

Snow or debris should not be allowed to accumulate in or around the unit. Do not permit overhanging structures or shrubs to obstruct condenser air discharge or vent outlet on your unit. These provide air for combustion and ventilation.

FILTER CARE

Single phase units are shipped without a filter and is the responsibility of the installer to secure a filter in the return air ductwork or install a Filter/Frame Kit (1FF0110).

A filter rack and a high velocity filters are standard on three phase units.

Filters must always be used and must be kept clean. When filters become dirt laden, insufficient air will be delivered by the blower, decreasing your units efficiency and increasing operating costs and wear-and-tear on the unit and controls.

OUTDOOR COIL

Dirt should not be allowed to accumulate on the outdoor coil surface or other parts in the air circuit. Cleaning should be as often as necessary to keep the coil clean. Use a brush, vacuum cleaner attachment, or other suitable means. If water is used to clean the coil, be sure that the power to the unit is shut off prior to cleaning.

CAUTION

EXERCISE CARE WHEN CLEANING THE COIL SO THAT THE COIL FINS ARE NOT DAMAGED.

DO NOT PERMIT THE HOT CONDENSER AIR DISCHARGE TO BE OBSTRUCTED BY OVERHANGING STRUCTURES OR SHRUBS.

BURNER

At the beginning of each heating season, make a visual check of the main burner flame. If it is not possible to adjust for the proper flame, the burner may need cleaning.

TO CLEAN BURNERS

Remove them from the furnace as explained in Burner Instructions. Clean burners with hot water applied along top of the burner.

COMBUSTION AIR DISCHARGE

Visually inspect discharge outlet periodically to insure soot and dirt buildup is not excessive. If necessary, clean to maintain adequate combustion air discharge.

The manufacturer recommends that the furnace system be inspected once a year by a qualified serviceperson.

CLEANING FLUE PASSAGES AND HEATING ELEMENTS

With proper combustion adjustment the heating element of a gas fired furnace will seldom need cleaning. If the element should become sooted, it can be cleaned as follows:

1. Remove the burner assembly as outlined in BURNER INSTRUCTIONS.
2. Remove the screws securing the restrictor plate to the tube sheet.
3. Using a wire brush on a flexible wand, brush out the inside of each heat exchanger from the burner inlet and flue outlet ends.
4. Brush out the inside of the restrictor plate to the tube sheet.
5. If soot build-up is particularly bad, remove the vent motor and clean the wheel and housing.
6. After brushing is complete, blow all brushed areas with air or nitrogen. Vacuum as needed.
7. Replace parts in the order they were removed in steps 1 through 3.

REGISTERS

Supply air and return air registers must be open when the unit is in operation. Furniture must not block airflow in or out of the registers.

TABLE 1: GAS RATE - CUBIC FEET PER HOUR¹

SECONDS FOR ONE REV.	SIZE OF TEST DIAL	
	1/2 CU. FT.	1 CU. FT.
10	180	360
12	150	300
14	129	257
16	113	225
18	100	200
20	80	180
22	82	164
24	75	150
26	69	138
28	64	129
30	60	120
32	56	113
34	53	106
36	50	100
38	47	95
40	45	90
42	43	86
44	41	82
46	39	78
48	37	75
50	36	72
52	35	69
54	34	67
56	32	64
58	31	62
60	30	60

1. EXAMPLE: By actual measurement, it takes 38 seconds for the hand on the 1-cubic foot dial to make a revolution with just a 100,000 BTUH furnace running. Using this information, locate 28 seconds in the first column of the table. Read across to the column headed "1 Cubic Foot," where you will see that 95 cubic feet of gas per hour are consumed by the furnace at that rate. Multiply 95 x 1050 (the BTU rating of the gas obtained from the local gas company). The result is 99,750 BTUH which is close to the 100,000 BTUH rating of the furnace.

TROUBLESHOOTING

BEFORE CALLING A SERVICE-PERSON:

- A. Check thermostat setting and insure thermostat is calling for heat or cooling.
- B. Check thermostat for lint, dust, etc.
- C. Check fuses or circuit breakers.
- D. Check filters for excessive dust accumulation and/or restriction.

REPLACEMENT PARTS

REPLACEMENT PARTS FORM NO.	RESPECTIVE MODEL NO.
----------------------------	----------------------

SINGLE PACKAGE AIR CONDITIONER GAS/ELECTRIC (12/13 SEER)

035-19764-000	D*NZ024 - 060
---------------	---------------

All forms referenced in this manual may be ordered from:

Standard Register
Toll Free: 877-318-9675
Fax: 877-379-7920

SOME EFFICIENCY DO'S AND DON'TS

DON'T heat or cool unused areas. Reduce supply and return air flow to a minimum in areas which are not living spaces (storage rooms, garaged, basements, etc.).

DON'T be a "thermostat juggler". Moving your thermostat setting will not make your system heat or cool any faster. Adjust your thermostat to a comfortable setting and leave it there.

DON'T restrict air circulation. Placing furniture, rugs, etc. in such a way that they interfere with air vents will make your system work harder to achieve a comfortable temperature level. This requires more energy, which means greater cost to you.

DON'T heat or cool when you are away. If you are going to be away for a day or more, re-adjust your thermostat accordingly. Your furniture is far less demanding than you are when it comes to comfort levels. However, don't expect the sys-

tem to restore comfort conditions immediately upon returning home. It will take a little time.

DON'T locate lamps or other heat-producing appliances (radios, TV's, heaters, etc.) near your thermostat. The heat from these items will give your thermostat "false information" about the temperature in the room.

DO select a comfortable thermostat setting, but keep in mind that moderation in temperature selection will save energy.

DO turn on your kitchen exhaust fan when cooking and your bathroom exhaust fan when showering. Also, make sure your clothes dryer is properly vented. If these items are neglected, an excess heat and humidity condition may be created,

causing your air conditioning system to run longer.

DO set your thermostat a few degrees lower than normal several hours before entertaining a large group of people in a relatively small area. People give off a considerable amount of heat and moisture in a closed area.

DO keep drapes and Venetian blinds closed when practical. These items provide insulation against heat loss/gain.

DO contact a qualified serviceperson to make repairs or adjustments to your system. They have been trained to perform this service.



Subject to change without notice. Printed in U.S.A.
Copyright © by Unitary Products Group 2003. All rights reserved.

035-19776-000-B-1003
Supersedes: 035-19776-000-A-0903

**Unitary
Products
Group**

**5005
York
Drive**

**Norman
OK
73069**