

LIST OF PRODUCTS

- * Digital Multimeter
- * Digital AC & AC/DC Clampmeter
- * AC Clamp Adaptor
- * AC/DC Current Adaptor
- * Transistorised Electronic Analog & Digital Insulation Resistance Testers(upto 10 KV)
- * Digital Sound Level Meter & Sound Level Calibrator
- * Digital contact & Non-contact Type Tachometer
- * Digital Non-contact (infrared) Thermometer
- * Thermo Hygrometer
- * Thermo Anemometer
- * Wood & Paper Moisture Meter
- * Distance Meter
- * Digital Hand Held Temperature Indicators
- * Digital Lux Meter
- * Network Cable Tester
- * Power Factor Regulator
- * Maximum Demand Controller/Digital Power Meter
- * Earth Resistance Tester

KUSAM-MECO

17, Bharat Industrial Estate, T. J. Road, Sewree (W),
Mumbai-400015. INDIA

Sales Direct: 24156638 Tel.:(022)2412 4540, 2418 1649 Fax:2414 9659

E-mail : kusam_meco@vsnl.net, Website : www.kusamelectrical.com,
www.kusam-meco.co.in

KUSAM-MECO

An ISO 9001:2008 Company

**DIGITAL
MULTIMETER
KM 6050**

**OPERATION
MANUAL**

KUSAM-MECO



KUSAM-MECO

**TAKE MEASUREMENT CAREFULLY AND YOU'LL
SPARE YOUR METER AND YOURSELF, SOME PAIN**

Nearly every electrical engineer has a hand held Multimeter. We sometimes take them for granted, until we damage them or "burn them out". If you incorrectly connect your DMM to a circuit or have the DMM on wrong setting, you damage the meter and possibly hurt yourself. You can also get into trouble if you try to measure the voltage across a charged capacitor.

DMM users frequently burn their meters by trying to measure current the same way as they measure voltage, Remember, you measure voltage across a circuit, and current through a circuit. When you use the current input, your DMM becomes a low impedance circuit element. If you accidentally connect this low impedance path across your circuit, you'll effectively short-circuit it. You can, therefore send high current through your meter and severely damage it. Unless the meter has a fused input, you can even get an explosion or fire.

Even if you correctly insert your DMM into the circuit, you can still damage your meter. Don't try to measure current in excess of your meter's capacity. Handheld DMMs usually have a maximum current rating of 10A or 20A.

If you are measuring current in industrial environment, you can easily exceed those ratings. The best way to avoid damage is to use a clamp meter or to connect a clamp attachment to your DMM.

To prevent excess current from flowing through your meter, always disconnect the test leads from the circuit under test whenever you change DMM functions. Set your meter to the correct function, say current and its highest range for the setting, say 20A. Next, connect the test leads before you apply power to the circuit. To be safe, start by setting your meter to its highest range first.

TABLE OF CONTENTS

TITLE	PAGE
SAFETY.....	1
CAUTION & SAFETY SYMBOL.....	2
GENERAL SPECIFICATION.....	3
ELECTRICAL SPECIFICATION.....	4
ELECTRICAL SYMBOLS.....	8
MULTIMETER STRUCTURE.....	9
MEASUREMENT PROCEDURE.....	10
MAINTENANCE.....	23
TEST CERTIFICATE.....	25
WARRANTY.....	26

1. GENERAL DESCRIPTION

KM 6050 Digital Multimeter is featured with precise design, convenient operation, high performance multifunction, a new protection holster and big LCD display. To avoid improper operation, the current jack applies mechanical protection device. Only when you select current measurement, the mA or 20A jack is open accordingly. Otherwise this jack is closed to avoid inserting the test lead wrong. "V Hz" is equipped with PTC heat sensitive element at the input terminal and this has efficient protection for the Function / Range switch. You can select different models to measure DCV, DCA, ACV, ACA, Resistance, Capacitance, Frequency, Temperature, Diode, hFE and Continuity. This type can be applied in engineering project, experiment test, production test work in the open air, and electrical repairs, etc.

2. SAFETY PRECAUTIONS AND PROCEDURES

- 1) For your own safety and that of the apparatus, you must read and follow the procedure described in this instruction manual.
- 2) Never use the instrument before replacing the back cover, or having the risk of electronic shock.
- 3) If any unusual condition of testing end and attachment of the meter such as breakage, deformation, fracture, foreign substance, no display, etc, do not conduct any measurement.
- 4) You must first take out the test leads before changing to different current measuring positions and then turn the function / range switch so as to avoid damaging mechanical protection device.

- 5) Never input signal level exceeding the limit value to avoid shock or damaging the instrument.
- 6) Don't turn the function / range switch when taking measurement.
- 7) The potential difference between the measurement common terminal COM and earth should not exceed 1000V to avoid electric shock.
- 8) Take extreme care if the tested voltage is over DC 60V and AC 42V to avoid electric shock.
- 9) When symbol "  " occurs on the LCD, it indicates low battery. Battery should be replaced to ensure measurement accuracy.
- 10) Fuse inside must be in a good condition and they must be replaced, if necessary, with an identical model.

Terms in this manual

 **Warning:** Identifies conditions and actions that could result in serious injury or even death to the user.

 **Caution:** Identifies conditions and actions that could cause damage or Malfunction in the instrument.

3. GENERAL SPECIFICATIONS

- Low power consumption CMOS double integration, A/D transform integrated circuit, Auto zero Calibration, Auto polarity display, Data hold, low battery and Over-range indication.
- DC Basic Accuracy : ± 0.05
- Capacitance measurement : 0.1~200 F
- Test lead jack mechanical protection function and full range over-load protection function.
- Auto power off function : The meter will shut off automatically about 15minutes after power is on to avoid forgetting to turn off the meter after using it.
- Max reading : 19999(4½)
- LCD Display : 70 x 48mm big screen, high contrast, Word height : 28mm
- Power : one 9V battery.
- Low battery indication : "  " will occur on the left top of the LCD.
- Dimension : 192 x 88 x 42mm
- Weight : approx 400g (including battery and holster).
- Environmental condition :
 - Operation Temperature : 0°C ~ 40°C
 - Relative Humidity : <85%
 - Storage Temperature : -10°C ~ 50%
 - Relative humidity : <85%

4. ELECTRICAL SPECIFICATIONS

Accuracy : \pm (% reading + digit) one year warranty.

Environment temperature : $23^{\circ}\text{C} \pm 5^{\circ}\text{C}$

Relative humidity : $<75\%$

DC VOLTAGE

Range	Accuracy	Resolution
200 mV	$\pm(0.05\% + 5)$	10 V
2 V		100 V
20 V		1 mV
200 V		10 mV
1000 V	$\pm(0.1\% + 5)$	100 mV

Input impedance : 10M

Overload protection : 250V, (for 200mV)

DC or AC peak value.

1000V (for other ranges)

AC VOLTAGE

Range	Accuracy	Resolution
2 V	$\pm(0.8\% + 10)$	100 V
20 V		1 mV
200 V		10 mV
1000 V	$\pm(1.2\% + 15)$	100 mV

Input impedance : 2M

Frequency Range : 40Hz ~ 400Hz

Overload protection : 250V, (for 200mV)

DC or AC peak value.

1000V (for other ranges)

Display : Average value (Sine RMS)

DC CURRENT

Range	Accuracy	Resolution
2 mA	$\pm(0.5\% + 2)$	100 nA
20 mA		1 A
200 mA	$\pm(0.75\% + 5)$	10 A
20 A	$\pm(2\% + 10)$	1 mA

Overload protection : 0.2A / 250VFuse.

Max input current : 20A(15 seconds max.)

Voltage drop measurement :

Full-range voltage drop : 200mV

AC CURRENT

Range	Accuracy	Resolution
2 mA	$\pm(0.8\% + 10)$	100 nA
20 mA		1 A
200 mA	$\pm(1.5\% + 10)$	10 A
20 A	$\pm(2\% + 10)$	1 mA

Overload protection : 0.2A / 250VFuse.

Max input current : 20A (15 seconds max.)

Voltage drop measurement :

Full-range voltage drop : 200mV

Frequency Range : 40Hz ~ 400 Hz

Display : Average Value (Sine RMS)

RESISTANCE

Range	Accuracy	Resolution
200	$\pm(0.2\% + 5)$	0.01
2 K	$\pm(0.2\% + 1)$	0.1
20 K		1
200 K		10
2 M		100
20 M	$\pm(0.5\% + 5)$	1 K
200 M	$\pm(0.5\% + 10)$	10 K

Overload protection : 250V, DC or AC peak value.

Open circuit Voltage : <1V

(2.8V in the 200M position).

Note : It is normal that the test lead short-circuit displays approx. 10 digits in the 200M position. Please deduct these 10 digits from reading when measuring.

CAPACITANCE

Range	Accuracy	Resolution
2 nF	$\pm(2.5\% + 10)$	0.1 pF
20 nF		1 pF
200 nF		10 pF
2 F		100 pF
200 F	$\pm(5\% + 3)$	10 nF

Frequency measurement : Approx 400Hz.

Voltage measurement : Approx 40mV.

FREQUENCY

Range	Accuracy	Resolution
20 kHz	$\pm(2\% + 5)$	1Hz



Voltage Protection : 250V DC or AC peak value.

Input sensitivity : 150 mV RMS.

TRIODE HFE PARAMETER MEASUREMENT









Range	Description	Test Condition
hFE	It can measure NPN or PNP type transistor triode hFE parameter. Indication range:0-1000	1b approx 10 A, Vec approx 2.8V

DIODE AND CONTINUITY MEASUREMENT

Range	Description	Test Condition
	Indicate approx forward voltage drop of diode	Forward-way current is approx 1mA, contry-way voltage is approx 2.8V
	The buzzer inside sounds when continuity Resistance is <30	Open Circuit Voltage is approx 2.8V

Overload protection : 250V DC or AC peak value.

ELECTRICAL SYMBOLS

	DC Current or Voltage
	AC Current or Voltage
	Diode
	Buzzer
	Low Battery
	Cautions
	Double Insulation
	Earth (Ground)
	Danger High Voltage

6. MULTIMETER STRUCTURE

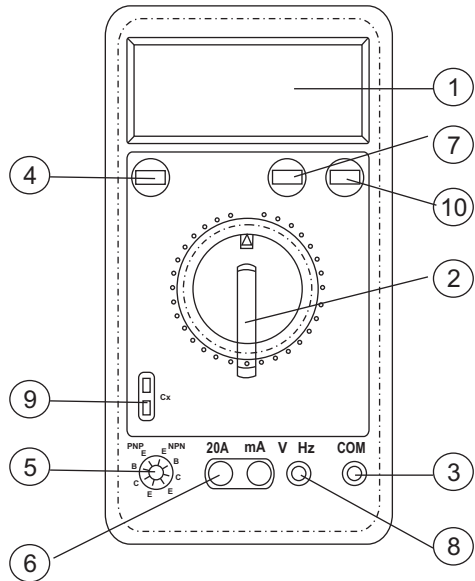

1. LCD display
2. Function / range selection
3. Test lead jack
4. Power switch
5. Triode measurement jack
6. Test lead jack resistance board
7. Backlight button
8. Test leads socket : V . Hz
9. Capacitance Socket.
10. Data Hold.

7. MEASUREMENT PROCEDURE

Press POWER key. If the battery is low “” symbol will display on the left top of LCD. Now you need to replace the battery.

Select the function and range needed.

1. DC Voltage Measurement :

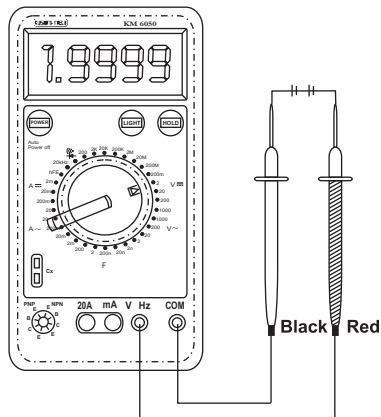

- (1) Set the function / range switch in DCV range.
- (2) Insert the black test lead into COM jack, and the red test lead into exposed test lead jack (V Hz jack). Connect the test lead to the tested load or the signal resources in parallel. The meter will indicate the polarity of the red test lead at the same time as it indicates the voltage reading.

Remark :

- A. If the tested voltage value is unknown, you should select the highest range.
- B. When only “1” occurs, it means the input voltage has exceeded the selected range, please select a higher range.
- C. “” indicates not to measure voltage over 1000V. Although it may display the digit, it may damage the meter.
- D. Take extreme care when measuring high voltage.

2. AC Voltage Measurement :

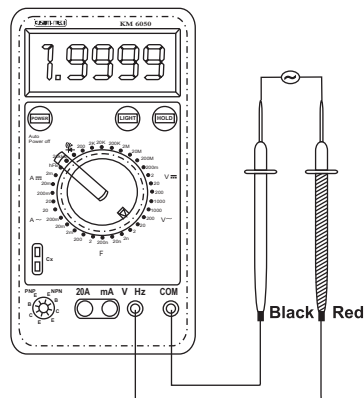

- (1) Set the function / range switch on ACV range.
- (2) Insert the black test lead into COM jack, and the red lead into exposed test lead jack (V Hz jack). Connect the test lead to the tested load or signal.

Remark :

- A. Refer to DCV measurement remarks A, B, C, D.
- B. "△" indicate not to measure the voltage over 1000V. Although it is possible to display the reading, it will probably damage the meter.

3. DC Current Measurement :

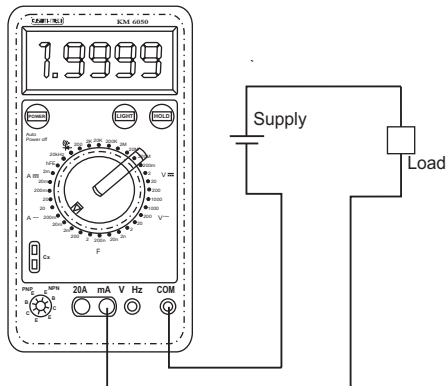

- (1) Remove the test lead and set the function / range switch on DCA range.
- (2) Insert the black test lead into COM jack and the red one into the exposed test lead jack (mA jack or 20A jack). Connect the test lead to the tested circuit in series. The meter will indicate the polarity of the red test lead at the same time as the meter indicate the current reading.

Remark :

- A. If the current value is unknown before measurement, select the highest range.
- B. When only "1" occur that indicates the tested current has exceeded the selected range. You should select a higher range.
- C. When doing mA jack input, overload may melt the fuse inside. Now replace the Fuse. The Fuse specifications is 0.2A/ 250V.
- D. When doing 20A jack input, time for inputing the highest current 20A should not exceed 15 seconds.

4. AC Current Measurement :

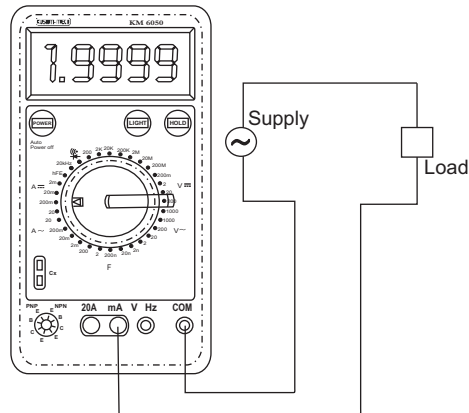

- (1) Remove the test lead and set the function / range switch on ACA range position. Refer to DCA measurement (1).
- (2) Insert the black test lead into COM jack and the red test lead into the exposed test lead jack (mA jack or 20A jack). Connect the test lead to the tested circuit in series.

Remark : Refer to DCA measurement remarks A, B, C, D.

5. Resistance Measurement :

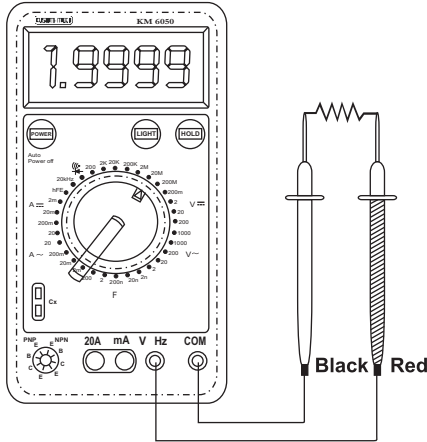

- (1) Set the function / range switch on range position needed.
- (2) Insert the black test lead into COM jack and the red test lead into the exposed V Hz jack (The red test lead is the positive polarity of the measurement circuit). Connect the test lead to the two ends of the tested resistance.

Remark :

- A. When doing open circuit input, the meter is in the state of over-range, and only the highest digit "1" is displayed.
- B. When the tested resistance is over 1M , it takes a few seconds to stabilize the reading. It is normal for the H measurement.

C. You should turn off the power when measuring resistance in the circuit, and discharge the capacitors on the tested circuit.

D. 200M position, there are about 10 digits when the red & black test leads are in short-circuit. Deduct these digits from the reading when measuring.

6. Capacitance measurement :

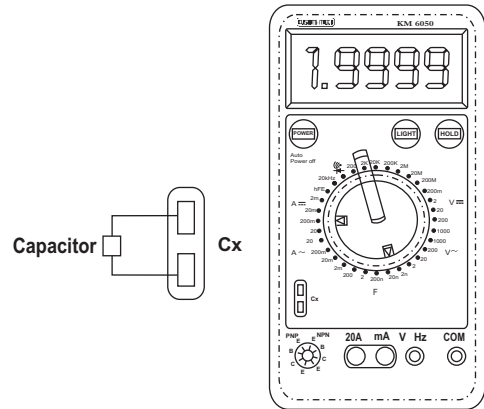

- (1) Set the function / range switch on the range position needed, waiting for the meter's Auto zero-calibration. It is normal that about 10 digits are left in 2 nF.
- (2) Discharge the capacitor.
- (3) Insert the capacitor under test into "Cx" jack and measure (It doesn't need the test lead).

Remark : ⚠

- A. Discharge the loaded capacitors, and then measure.
- B. It takes more time when measuring big capacitors.
- C. Measurement unit : $1\text{pF}=10^6 \text{ F}$; $1\text{nF}=10^3 \text{ F}$.
- D. Don't insert the capacitors with high voltage into the test jack direct.

7. Frequency Measurement:

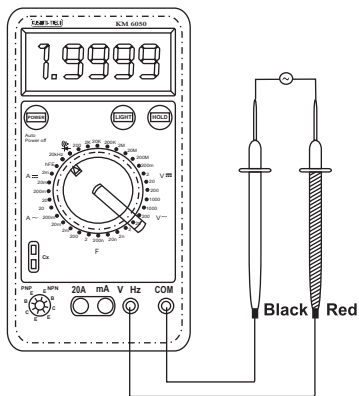

- (1) Set the function/range switch on Hz position.
- (2) Insert the black test lead into COM jack and the red test lead or the cable into the test lead jack (V Hz jack).

Remark:

- A. “⚠” Never supply the voltage over 250V to the input terminal. If the voltage value is 1000V RMS, you can get the measurement result, but that will exceed the accuracy range of the meter.

- B. If the tested signal is too strong, you should use the external attenuation so as not to damage the meter.
- C. Working in the noisy place, you had better use the shielded cable if you measure the small signal.

8. Transistor hFE parameter measurement

Insert Leads in this socket.

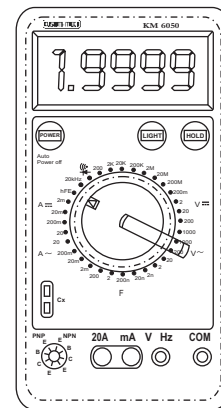
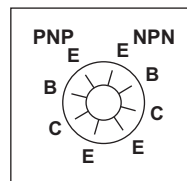

- (1) Set the function/range switch on hFE position.
- (2) First make sure the hFE is PNP type or NPN type and then insert the leads E, B, C into the respective sockets of the meter.
- (3) The meter displays approx hFE value. The measurement condition is : base current is approx 10 A, Vce approx 2.8V.

9. Diode → measurement :

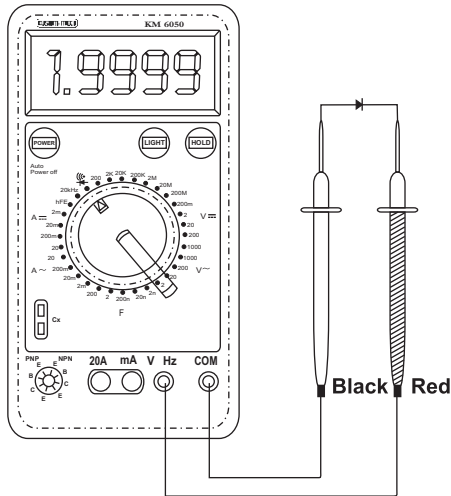

- (1) Set the function/range switch on the → position.
- (2) Insert the black test lead into COM socket and the red test lead into the exposed test lead socket (V Hz jack, and pay attention that the inner power of the red test lead is “+”polarity). Connect the red test lead to the two ends of the tested Diode, and the meter display Diode’s Forward-way voltage drop. The unit is “volt”; It will display over-range if the diode is connected in an opposite direction.

Remark :

- A. When the two test leads are in open-circuit state, it will display over-range (only “1” is displayed).
- B. Current going through the tested components is approx 1mA.

10. Continuity Test :

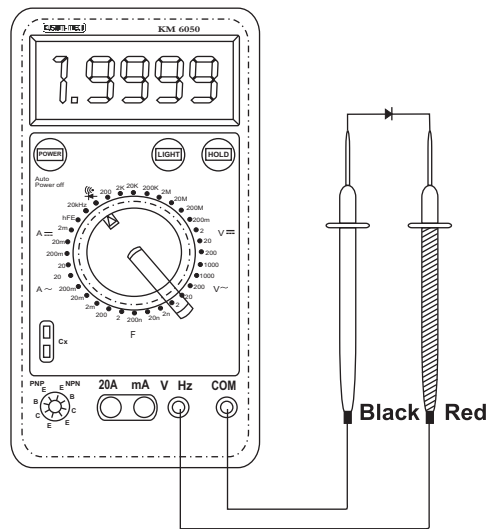

- (1) Set the function / range on \llcorner position.
- (2) Insert the black test lead into COM socket and the red one into V Hz jack, and connect the test lead to the two ends of the circuit to be tested.
- (3) If the resistance value between the two points to be tested is below 30 Ω , the buzzer will sound.

Remark :

You must cut off the power before you check the tested circuit. It will cause the meter to display wrong reading if the circuit is charged.

11) Data Hold Function :

The Hold function allows operator to hold the displayed digital values. When this function is enabled the display shows the “H” symbol. The Hold function will be disabled if the Hold key is pressed again or the position of the rotary switch is changed.

12) Mechanical Protection Function :

Before inserting the test lead, turn the function/ range switch in a circle (360°) and observe the motion of the resistance board. This will help you to get familiar with the meter’s function. Model KM 6050 digital Multimeter is provided with the mechanical protection function device as follows:

“ ● “ in the following table means the socket is closed. The black test lead can be inserted into “COM” jack.

Position of Function/Range Switch	Test lead blocked by the blocking board			
	\rightarrow V	Hz	mA	20A
AC / DC Voltage			●	●
AC/DC Current Except 20A	●			●
AC / DC Current 20A	●		●	
Resistance			●	●
Capacitance F			●	●
$\llcorner \rightarrow$			●	●
Triode hFE parameter			●	●
Frequency Hz			●	●

If you find the rotary switch doesn’t move, that’s because you forget to pull out the test lead. Don’t force the switch to move. You must pull out the test lead before turning the rotary switch or the meter’s mechanical protection system may be damaged.

13. Backlight Function

The meter is featured with backlight function for better use when the environment light is dim.

Press the "LIGHT" button to enable the backlight, push it again to turn off the light.

14. Select the display angle of the meter :

KM 6050 provided with protection holsters, which can support the meter in different angles as well as protect the meter. This is convenient to observe the reading.

8. MAINTENANCE

It is a precise electronic multimeter. Please take care to do the maintenance well.

1. Don't connect to the voltage over 1000 DCV or 1000 ACV.
2. Don't forget to pull out the test lead before turning the function / range switch so as not to damage the mechanical protection system.
3. Don't use the meter before replacing the back cover of it.
4. Battery replacement : Pull out the test lead and turn off the power before replacing the battery.
5. Fuse replacement : Press the off key to turn off the instrument, and disconnect the test leads from the input terminals. Remove the back cover screws and open the back cover. Replace the fuse / fuses with new fuse of the same type and rating : 0.2A/ 250V.
6. Remove the battery and put it in a dry and airy place if the meter is not used for a long time.
7. Don't change the inner circuit to avoid damage the meter.

9. ACCESSORIES

1. User's Manual
2. One Holster
3. One pair test lead

MUMBAI

TEST CERTIFICATE**DIGITAL MULTIMETER**

This Test Certificate warrants that the product has been inspected and tested in accordance with the published specifications.

The instrument has been calibrated by using equipment which has already been calibrated to standards traceable to national standards.

MODEL NO. **KM 6050**

SERIAL NO. _____

DATE: _____

ISO 9001
REGISTERED

WARRANTY

Each "KUSAM-MECO" product is warranted to be free from defects in material and workmanship under normal use & service. The warranty period is one year (12 months) and begins from the date of despatch of goods. In case any defect occurs in functioning of the instrument, under proper use, within the warranty period, the same will be rectified by us free of charges, provided the to and fro freight charges are borne by you.

This warranty extends only to the original buyer or end-user customer of a "KUSAM-MECO" authorized dealer.

This warranty does not apply for damaged Ic's, fuses, burnt PCB's, disposable batteries, carrying case, test leads, or to any product which in "KUSAM-MECO's" opinion, has been misused, altered, neglected, contaminated or damaged by accident or abnormal conditions of operation or handling.

"KUSAM-MECO" authorized dealer shall extend this warranty on new and unused products to end-user customers only but have no authority to extend a greater or different warranty on behalf of "KUSAM-MECO".

"KUSAM-MECO's" warranty obligation is limited, at option, free of charge repair, or replacement of a defective product which is returned to a "KUSAM-MECO" authorized service center within the warranty period.

THIS WARRANTY IS BUYER'S SOLE AND EXCLUSIVE REMEDY AND IS IN LIEU OF ALL OTHER WARRANTIES, EXPRESS OR IMPLIED, INCLUDING BUT NOT LIMITED TO ANY IMPLIED WARRANTY OF MERCHANTABILITY OR FITNESS FOR A PARTICULAR PURPOSE. "KUSAM-MECO" SHALL NOT BE LIABLE FOR ANY SPECIAL, INDIRECT, INCIDENTAL OR CONSEQUENTIAL DAMAGES OR LOSSES, INCLUDING LOSS OF DATA, ARISING FROM ANY CAUSE WHATSOEVER.

All transaction are subject to Mumbai Jurisdiction.

G 17, Bharat Industrial Estate, T. J. Road,
Sewree (W), Mumbai - 400 015. INDIA.

Sales Direct : (022) 24156638

Tel. : (022) 24124540, 24181649.

Fax : (022) 24149659

Email : kusam_meco@vsnl.net

Website : www.kusamelectrical.com,
www.kusam-meco.co.in