

Color Spot **575E** AT

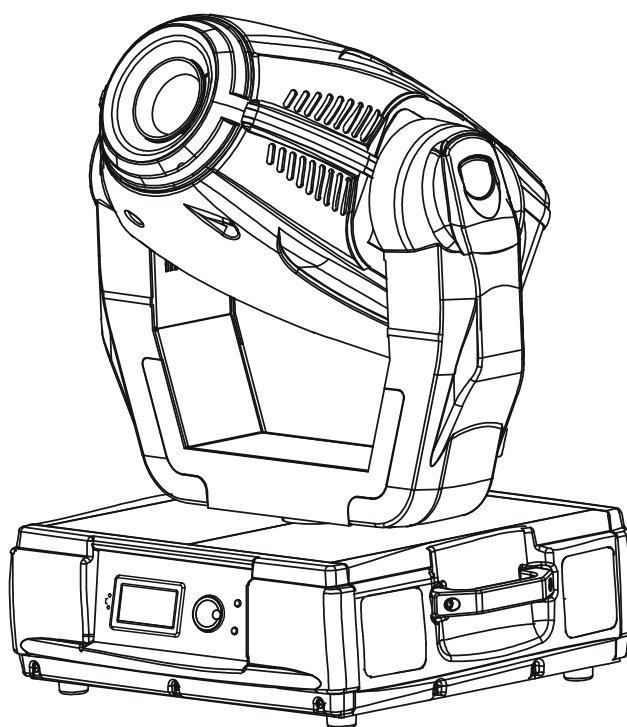

AT series

USER MANUAL

Version 1.0

ColorSpot 575E AT

Table of contents

1. Safety instructions	3
2. Operating determinations	4
3. Description of the device	5
4. Installation	6
4.1 Fitting the lamp	6
4.2 Lamp adjustment	7
4.3 Inserting/Exchanging colours and gobos	7
4.4 Replacing the 3-facet prism	8
4.5 Connection to the mains	9
4.6 Changing the power supply settings	9
4.7 Rigging the fixture	10
4.8 DMX-512 connection/connection between fixtures	12
4.9 Ethernet connection	13
5. DMX Protocol-version 1.0	15
6. Controller mode	21
6.1 DMX addressing	21
6.2 Remotely controllable functions	21
8. Control menu map	23
9. Control menu	27
9.1 Fixture Address	27
9.2 Fixture informations	28
9.3 Personality	29
9.4 Lamp On/Off	30
9.5 Test sequences	30
9.6 Manual mode	30
9.7 Stand-alone setting	30
9.8 Reset functions	31
9.9 Special functions	32
10. Low power mode	32
11. Error and information messages	33
12. Technical specifications	35
13. Maintenance and cleaning	39

CAUTION!
Keep this device away from rain and moisture!
Unplug mains lead before opening the housing!

**FOR YOUR OWN SAFETY, PLEASE READ THIS USER MANUAL CAREFULLY
BEFORE YOU INITIAL START - UP!**

1. Safety instructions

Every person involved with installation and maintenance of this device have to:

- be qualified
- follow the instructions of this manual

CAUTION!
Be careful with your operations.
With a high voltage you can suffer
a dangerous electric shock when touching the wires!

This device has left our premises in absolutely perfect condition. In order to maintain this condition and to ensure a safe operation, it is absolutely necessary for the user to follow the safety instructions and warning notes written in this manual.

Important:

The manufacturer will not accept liability for any resulting damages caused by the non-observance of this manual or any unauthorized modification to the device.

Please consider that damages caused by manual modifications to the device are not subject to warranty.

Never let the power-cord come into contact with other cables! Handle the power-cord and all connections with the mains with particular caution!

Make sure that the available voltage is not higher than stated on the rear panel.

Always plug in the power plug least. Make sure that the power-switch is set to OFF-position before you connect the device to the mains. The power-plug has to be accessible after installing the device.

Make sure that the power-cord is never crimped or damaged by sharp edges. Check the device and the power-cord from time to time.

Always disconnect from the mains, when the device is not in use or before cleaning it. Only handle the power-cord by the plug. Never pull out the plug by tugging the power-cord.

This device falls under protection class I. Therefore it is essential to connect the yellow/green conductor to earth.

The electric connection, repairs and servicing must be carried out by a qualified employee.
Do not connect this device to a dimmer pack.

Do not switch the fixture on and off in short intervals as this would reduce the lamp's life.

During the initial start-up some smoke or smell may arise. This is a normal process and does not necessarily mean that the device is defective.

Do not touch the device's housing bare hands during its operation (housing becomes hot)!
For replacement use lamps and fuses of same type and rating only.

CAUTION! EYEDAMAGES!
Avoid looking directly into the light source
(meant especially for epileptics)!

2. Operating determinations

This device is a moving-head spot for creating decorative effects and was designed for indoor use only.

If the device has been exposed to drastic temperature fluctuation (e.g. after transportation), do not switch it on immediately. The arising condensation water might damage your device. Leave the device switched off until it has reached room temperature.

Never run the device without lamp!

Do not shake the device. Avoid brute force when installing or operating the device.

Never lift the fixture by holding it at the projector-head, as the mechanics may be damaged. Always hold the fixture at the transport handles.

When choosing the installation-spot, please make sure that the device is not exposed to extreme heat, moisture or dust. There should not be any cables lying around. You endanger your own and the safety of others!

The minimum distance between light-output and the illuminated surface must be more than 2 meters.

Make sure that the area below the installation place is blocked when rigging, derigging or servicing the fixture.

Always fix the fixture with an appropriate safety-rope. Fix the safety-rope at the correct holes only.

Only operate the fixture after having checked that the housing is firmly closed and all screws are tightly fastened.

The lamp must never be ignited if the objective-lens or any housing-cover is open, as discharge lamps may explode and emit a high ultraviolet radiation, which may cause burns.

The maximum ambient temperature 40°C must never be exceeded. Otherwise, the lamp is switched off and the fixture is out of operation for 5 minutes.

CAUTION!

The lens has to be replaced when it is obviously damaged, so that its function is impaired, e. g. due to cracks or deep scratches!

Operate the device only after having familiarized with its functions. Do not permit operation by persons not qualified for operating the device. Most damages are the result of unprofessional operation!

CAUTION!

The lamp has to be replaced when it is damaged or deformed due to the heat!

Please use the original packaging if the device is to be transported.

Please consider that unauthorized modifications on the device are forbidden due to safety reasons!

If this device will be operated in any way different to the one described in this manual, the product may suffer damages and the guarantee becomes void. Furthermore, any other operation may lead to dangers like short-circuit, burns, electric shock, burns due to ultraviolet radiation, lamp explosion, crash etc.

3. Description of the device

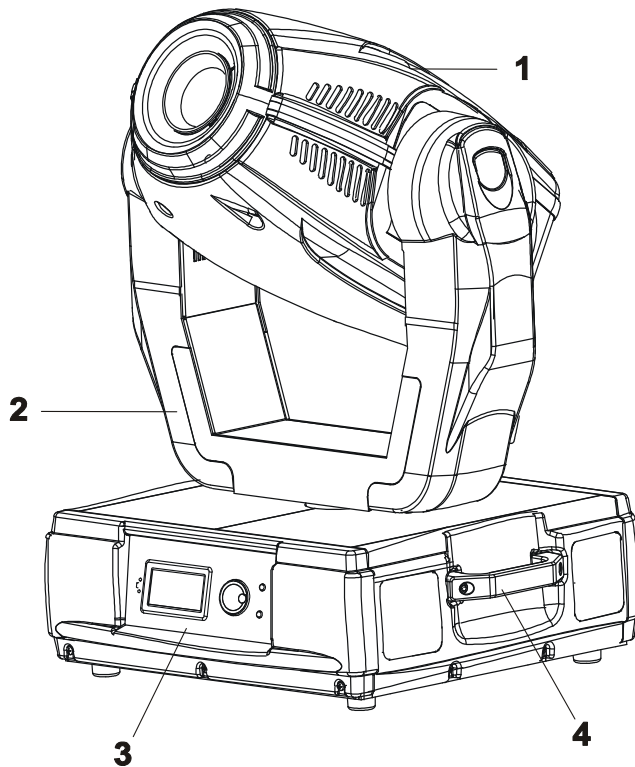

- 1 - Moving head
- 2 - Yoke
- 3 - Front panel
- 4 - Handle

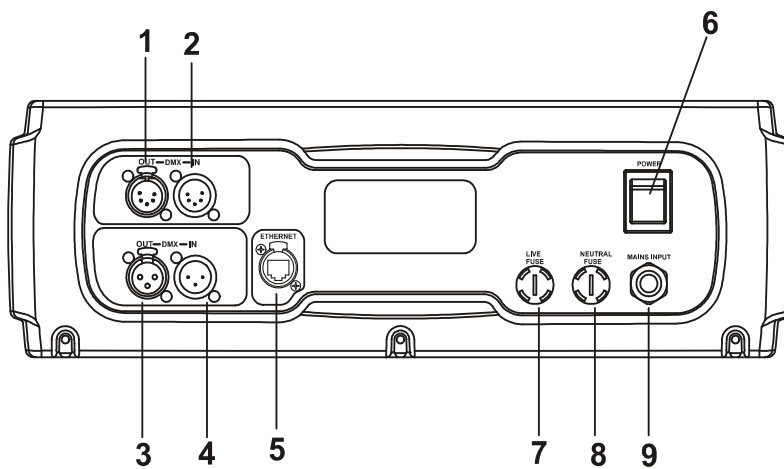

- Rear panel:**
- 1 - 5-pin DMX output
 - 2 - 5-pin DMX input
 - 3 - 3-pin DMX output
 - 4 - 3-pin DMX input
 - 5 - Ethernet input
 - 6 - Power switch
 - 7 - Fuse holder-live
 - 8 - Fuse holder-neutral
 - 9 - Power cord

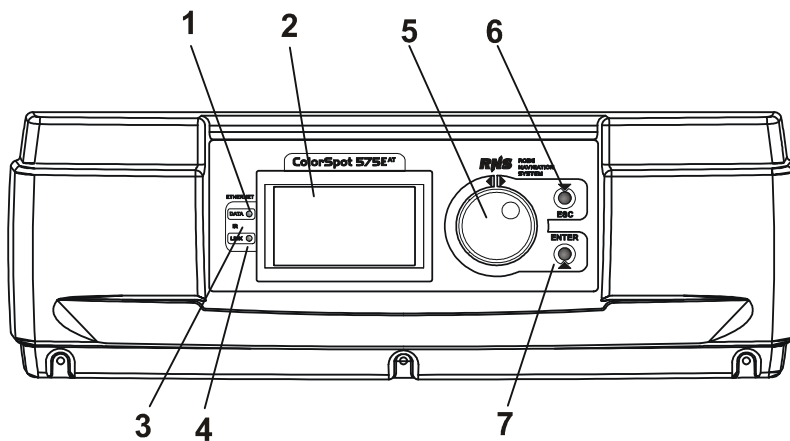

- Front panel:**
- 1 - Ethernet indicator
 - 2 - Display
 - 3 - Infra-red sensor
 - 4 - Data transfer indicator
 - 5 - RNS control wheel
 - 6 - Escape button
 - 8 - Enter button

4. Installation

4.1 Fitting the lamp

DANGER!
Install the lamps with the device switched off only.
Unplug from mains before !

To insert the lamp MSR 575W/2 loosen the lamp cover at the rear of head (see the drawings) by removing the 3 fastening screws which are marked "X,Y,Z". Carefully pull out the cover with the lamp socket assembly. If changing the lamp, remove the old lamp from the socket. Insert the lamp to the socket.

Do not install a lamp with a higher wattage! A lamp like this generates temperatures the device is not designed for. Damages caused by non-observance are not subject to warranty. Please follow the lamp manufacturer's notes! Do not touch the glass-bulb with bare hands during the installation! Make sure that the lamp is installed tightly into the lampholder system.

Reclose the lamp cover and tighten the 3 screws.

Before striking the lamp, reset the "Lamp On Time" and "Lamp Strikes" counters in "Fixture information" menu of the control board.

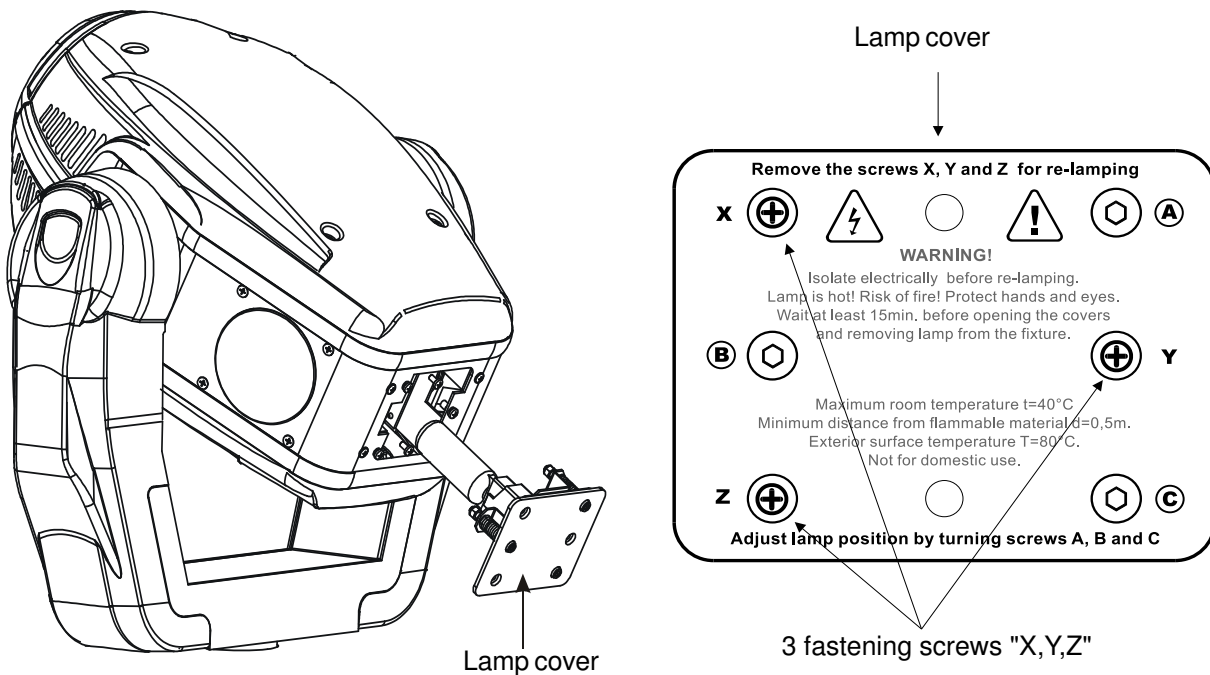

Do not operate this fixture with opened housing-cover!

4.2 Lamp adjustment

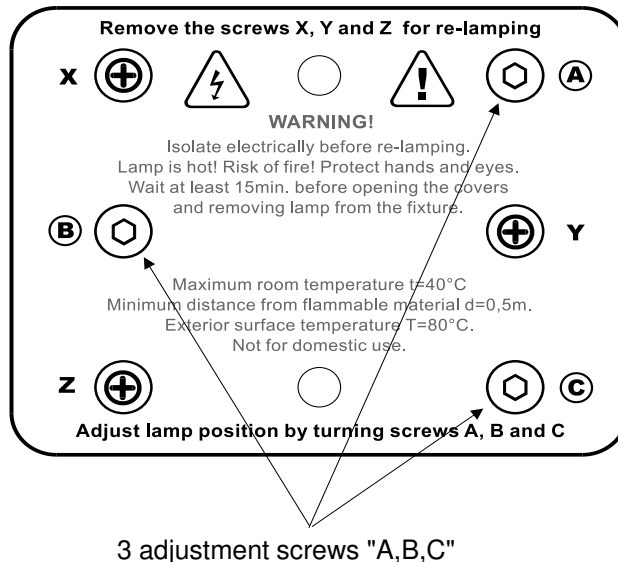

The ColorSpot 575E AT lamp holder is aligned at the factory. Due to differences between lamps, fine adjustment may improve light performance.

Strike the lamp, open the shutter and the iris, set the dimmer intensity onto 100% and focus the light on a flat surface (wall). Center a hot-spot (the brightest part of the image) by using the 3 adjustment screws "A,B,C". Turn one screw after another a quarter-turn clockwise (counter-clockwise) to set the hot-spot in the center of the image. If you cannot detect the hot-spot, adjust the lamp until the light is evenly distributed.

4.3 Inserting/Exchanging colours and gobos

DANGER!
Install the colours gobos with the device switched off only.
Unplug from mains before!

If you wish to use other forms and patterns as the standard gobos, or if colours are to be exchanged, open the top cover of the head by loosening 4 quarter-turn fasteners on the top cover.

Colour wheel:

Gently bend out the colour module to release it from the 3 distance slots and eject it from the pressing snap. Put the new colour module back under the pressing snap and push it to the distance slots.

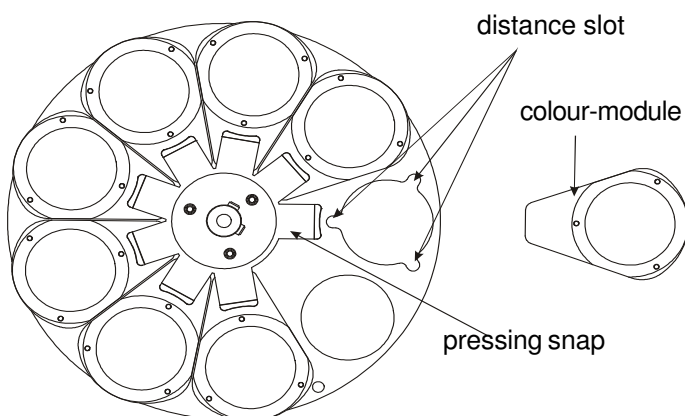

Stat.gobo wheel:

Gently bend out the gobo module to release it from the 3 distance slots and eject it from the pressing snap. Put the new gobo module back under the pressing snap and push it to the distance slots.

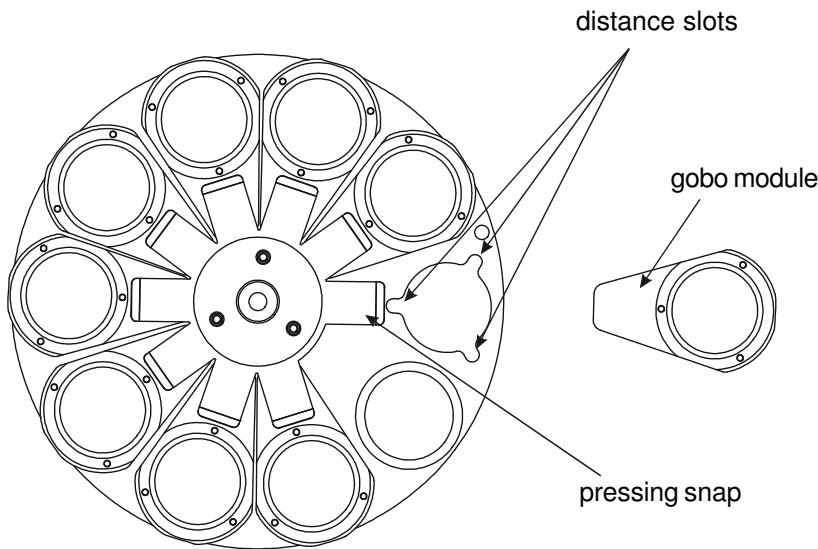

Rotating gobo wheel:

Gently bend out the gobo module to release it from the distance slots and eject it from the pressing snap. Press the ends of the fixation ring together with an appropriate tool and remove it from the gobo holder. Remove the gobo and insert the new gobo. Press the ends of the fixation ring together and insert it in the front of the gobo. Put the gobo module back under the pressing snap and push it to the distance slots.

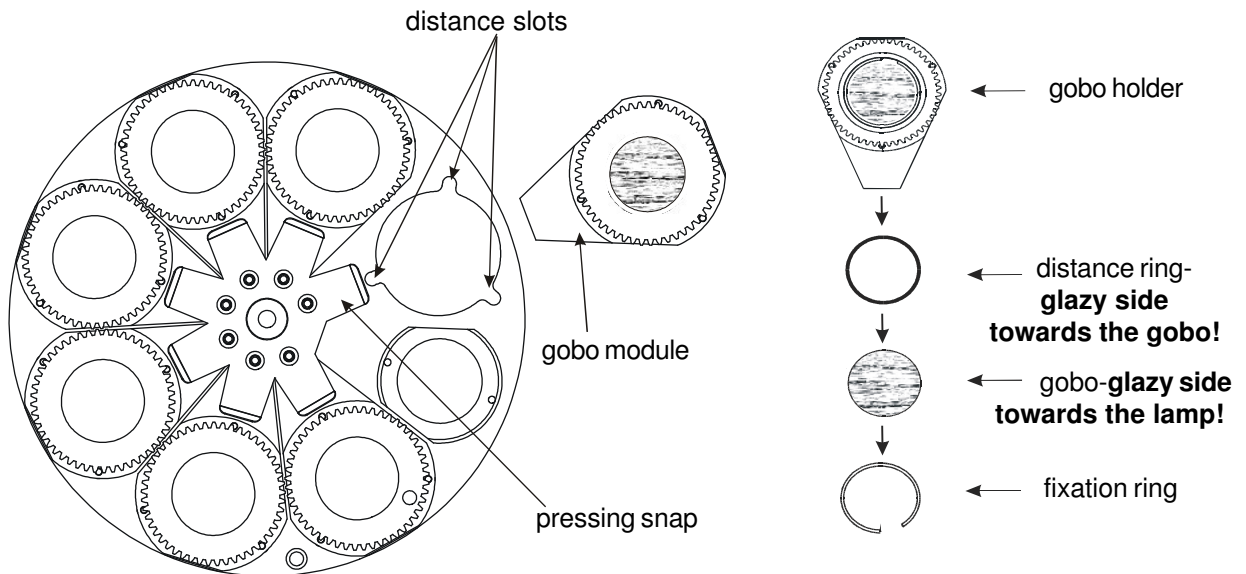

CAUTION!
The gobo holder with the magnet must be placed in the same position as it was placed before gobo replacement!

4.4 Replacing the 3-facet prism

Gently bend out the prism holder to release it from the fixative holes of prism module and eject it from the pressing snap. Put the new prism holder back under the pressing snap and push it to the 3 fixative holes.

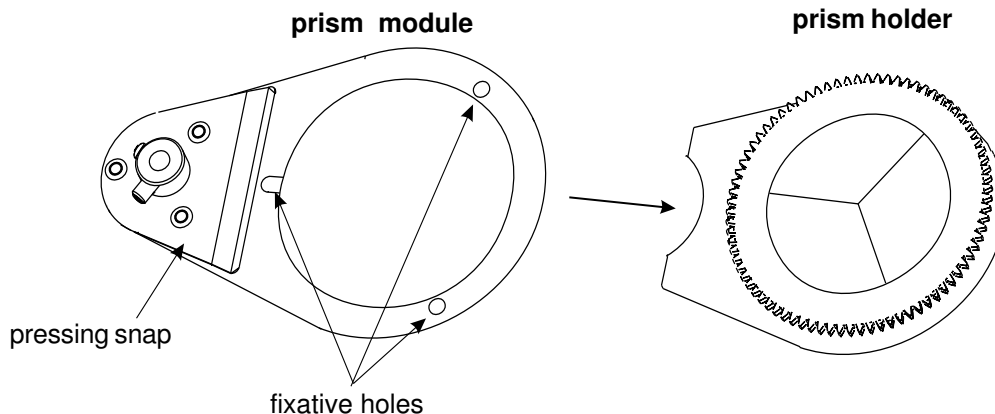

4.5 Connection to the mains

Verify the power supply settings before applying power!

If you wish to change the power supply settings, see the chapter below.
 Connect the fixture to the mains with the enclosed power plug. If you need to install other power plug on the power cable, follow the identification table below.
 The earth has to be connected!

Do not connect the fixture to a dimmer system!

The occupation of the connection-cables is as follows:

Cable (EU)	Cable (US)	Pin	International
Brown	Black	Live	L
Light blue	White	Neutral	N
Yellow/Green	Green	Earth	

4.6 Changing the power supply settings

Electronic ballast

The operating range of the electronic ballast is 90 VAC-265 VAC, 50-60Hz. The transformer has to be set to the local AC voltage.

If you want to change the power supply settings, follow the instructions:

1. Disconnect the fixture from AC power.
2. Remove the both top base covers by loosening the 12 screws.
3. Move the wire (3) on the transformer connection block to the position according to the desired voltage.
5. Close the base before applying AC power.

Example:

Power supply settings: 230V/50Hz

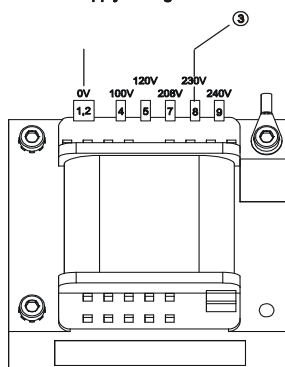

4.7 Rigging the fixture

DANGER TO LIFE!
Please consider the respective national norms during the installation!
The installation must only be carried out by an authorized dealer!

The installation of the projector has to be built and constructed in a way that it can hold 10 times the weight for 1 hour without any harming deformation.

The installation must always be secured with a secondary safety attachment, e.g. an appropriate catch net. This secondary safety attachment must be constructed in a way that no part of the installation can fall down if the main attachment fails.

When rigging, derigging or servicing the fixture staying in the area below the installation place, on bridges, under high working places and other endangered areas is forbidden.

The operator has to make sure that safety-relating and machine-technical installations are approved by an expert before taking into operation for the first time and after changes before taking into operation another time.

The operator has to make sure that safety-relating and machine-technical installations are approved by an expert after every four year in the course of an acceptance test.

The operator has to make sure that safety-relating and machine-technical installations are approved by a skilled person once a year.

The projector should be installed outside areas where persons may walk by or be seated.

IMPORTANT! OVERHEAD RIGGING REQUIRES EXTENSIVE EXPERIENCE, including (but not limited to) calculating working load limits, installation material being used, and periodic safety inspection of all installation material and the projector. If you lack these qualifications, do not attempt the installation yourself, but instead use a professional structural rigger. Improper installation can result in bodily injury and/or damage to property.

The projector has to be installed out of the reach of people.

If the projector shall be lowered from the ceiling or high joists, professional trussing systems have to be used. The projector must never be fixed swinging freely in the room.

Caution: Projectors may cause severe injuries when crashing down! If you have doubts concerning the safety of a possible installation, do NOT install the projector!

Before rigging make sure that the installation area can hold a minimum point load of 10 times the projector's weight.

Danger of fire !
When installing the device, make sure there is no highly inflammable material (decoration articles, etc.) in between a distance of min. 0,7 m.

CAUTION!
Use 2 appropriate clamps to rig the fixture on the truss.
Follow the instructions mentioned at the bottom of the base.
Make sure that the device is fixed properly! Ensure that the structure (truss) to which you are attaching the fixtures is secure.

The projector can be placed directly on the stage floor or rigged in any orientation on a truss without altering its operation characteristics .

For overhead use, always install a safety-rope that can hold at least 10 times the weight of the fixture. You must only use safety-ropes with screw-on carabines. Pull the safety-rope through the two apertures on the bottom of the base and over the trussing system etc. Insert the end in the carabine and tighten the fixation screw.

Fixation via the omega holders

1. Bolt each clamp (1) to the omega holder (4) with M12 bolt and lock nut through the hole in the holder.
2. Fasten the omega holders on the bottom of the base by inserting both quick-lock fasteners (3) into the holes of the base and tighten fully clockwise.
3. Fasten the safety-rope (2) through the two apertures on the bottom of the base and over the trussing system.

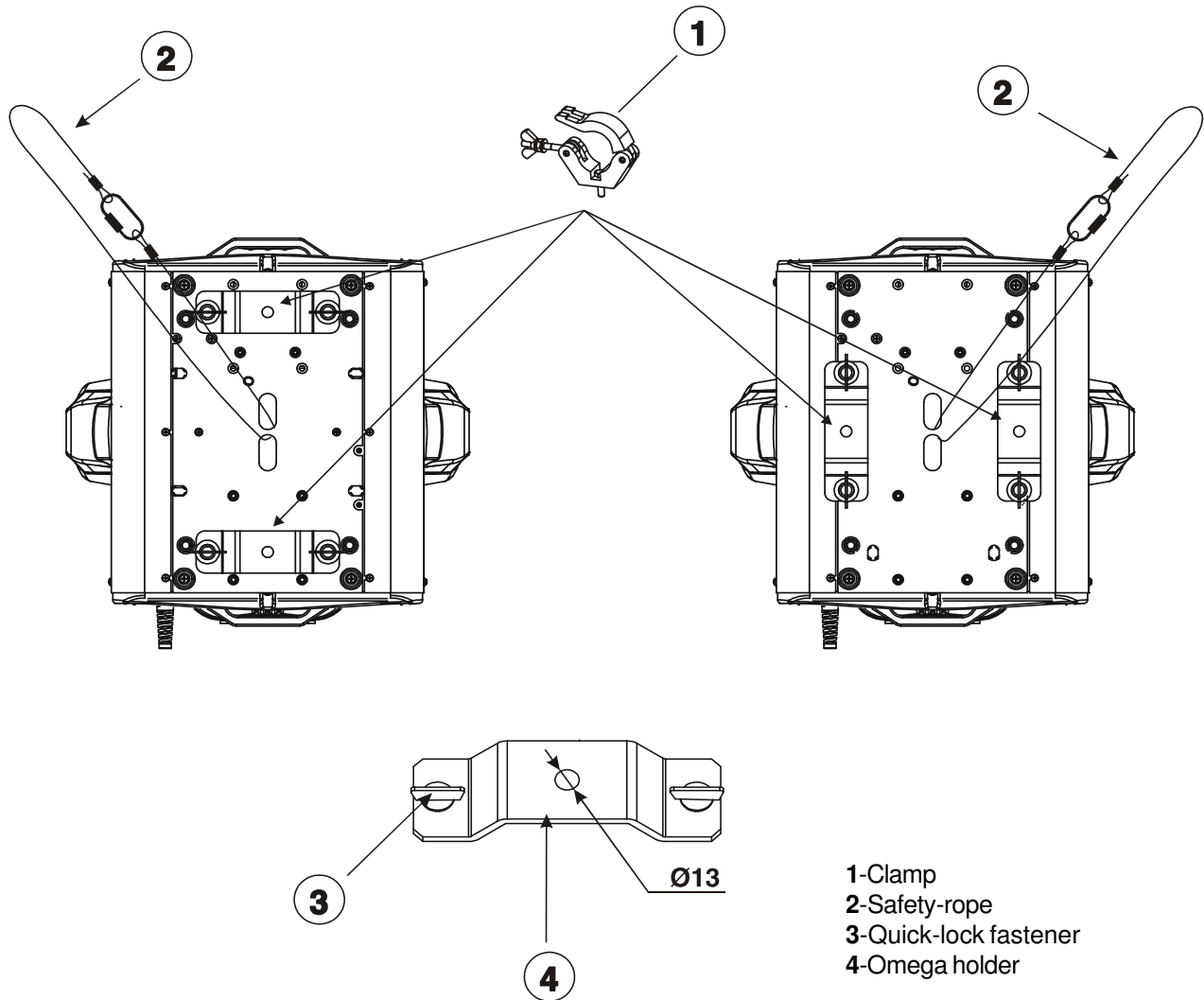

**When installing fixtures side-by-side,
avoid illuminating one fixture with another!**

DANGER TO LIFE!
**Before taking into operation for the first time, the installation has to be approved
by an expert!**

4.8 DMX-512 connection/connection between fixtures

The fixture is equipped with both 3-pin and 5-pin XLR sockets for DMX input and output. The sockets are wired in parallel.

Only use a shielded twisted-pair cable designed for RS-485 and 3-pin or 5-pin XLR-plugs and connectors in order to connect the controller with the fixture or one fixture with another.

DMX - output

XLR mounting-sockets (rear view):

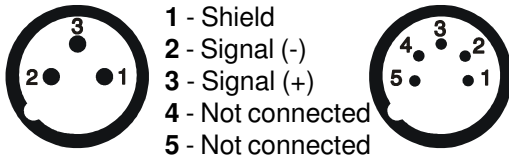

DMX-input

XLR mounting-plugs (rear view):

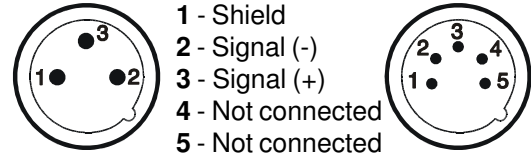

If you are using the standard DMX controllers, you can connect the DMX output of the controller directly with the DMX input of the first fixture in the DMX-chain. If you wish to connect DMX-controllers with other XLR-outputs, you need to use adapter-cables.

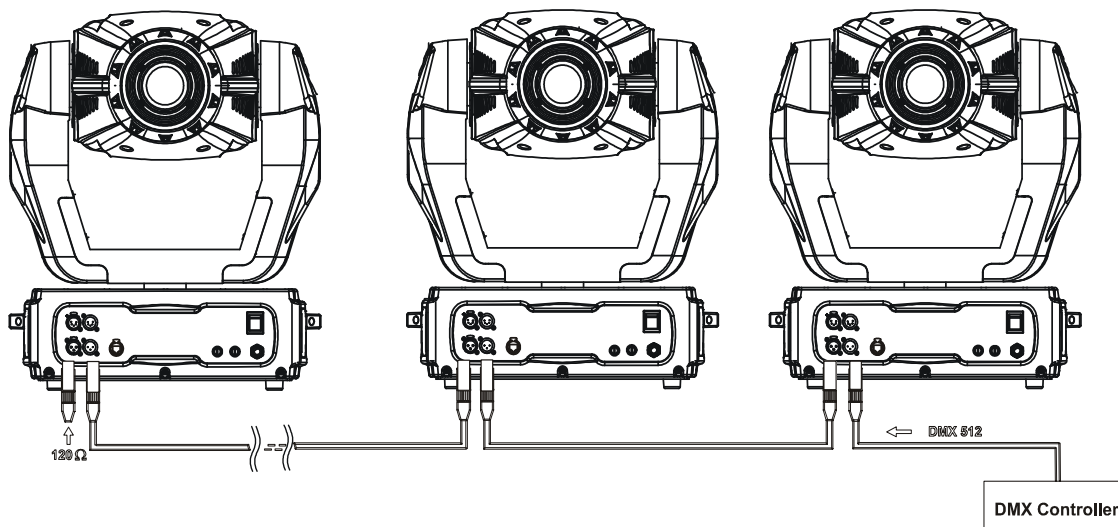

Building a serial DMX-chain:

Connect the DMX-output of the first fixture in the DMX-chain with the DMX-input of the next fixture. Always connect one output with the input of the next fixture until all fixtures are connected.

Caution: At the last fixture, the DMX-cable has to be terminated with a terminator. Solder a 120 Ω resistor between Signal (-) and Signal (+) into a 3-pin XLR-plug and plug it in the DMX-output of the last fixture.

4.9 Ethernet connection

The fixtures on a data link are connected to the Ethernet with Art-Net communication protocol. The controlling software from PC (or lighting console) has to support Art-Net protocol.

Art-Net communication protocol is a 10 Base T Ethernet protocol based on the TCP/IP. Its purpose is to allow transfer of large amounts of DMX 512 data over a wide area using standard network technology.

IP address is the Internet protocol address. The IP uniquely identifies any node (fixture) on a network.

The Universe is a single DMX 512 frame of 512 channels.

The ColorSpot 575E AT is equipped with 8-pin RJ-45 socket for Ethernet input. Use a network cable category 5 (with four "twisted" wire pairs) and standard RJ-45 plugs in order to connect the fixture to the network.

RJ-45 socket (front view):



- | | |
|------------------|------------------|
| 1- TD+ | 5- Not connected |
| 2- TD- | 6- RX- |
| 3- RX+ | 7- Not connected |
| 4- Not connected | 8- Not connected |

RJ-45 plug (front view):

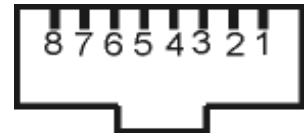

Patch cables that connect fixtures to the hubs or LAN sockets are wired 1:1, that is, pins with the same numbers are connected together:

1-1	2-2	3-3	4-4	5-5	6-6	7-7	8-8
-----	-----	-----	-----	-----	-----	-----	-----

If only the fixture and the computer are to be interconnected, no hubs or other active components are needed. A cross-cable has to be used:

1-3	2-6	3-1	4-8	5-7	6-2	7-5	8-4
-----	-----	-----	-----	-----	-----	-----	-----

Ethernet connection

Connect the Ethernet-inputs of all fixtures in the fixture chain with the network.

Option " Ethernet" has to be selected from "Set Ethernet Mode" menu on the fixture.

Set IP address (002.xxx.xxx.xxx / 010.xxx.xxx.xxx) and the Universe.

Example:

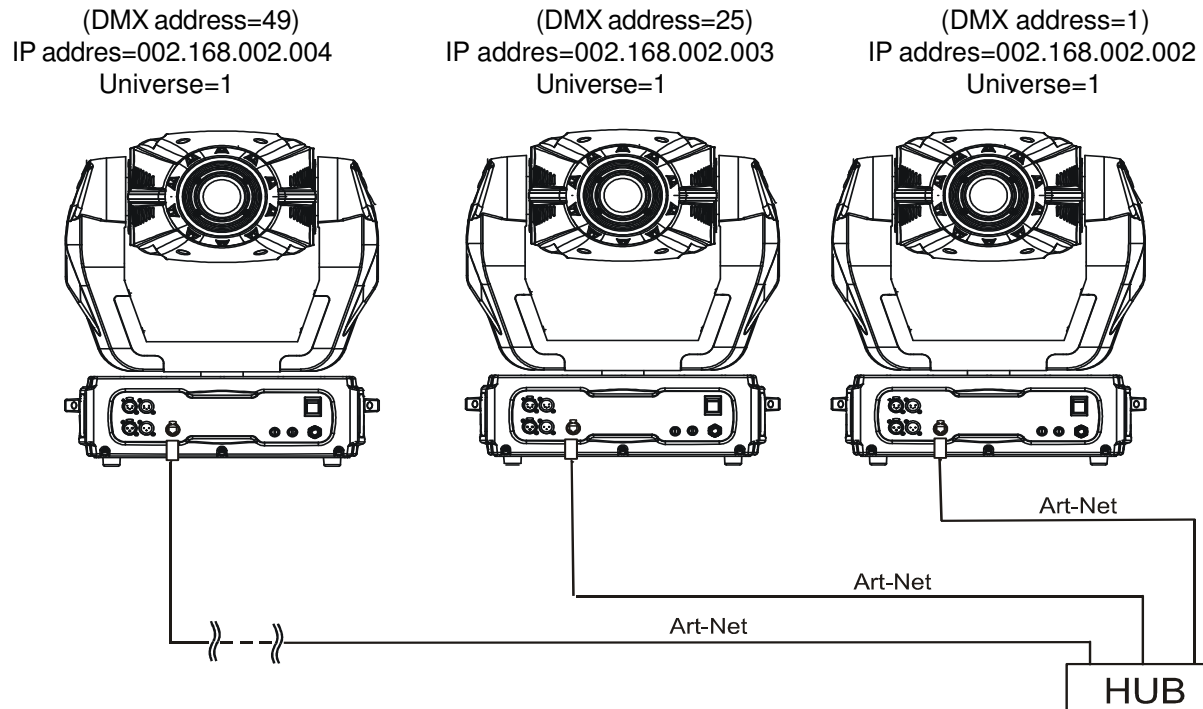

An advised PC setting: IP address: 002.xxx.xxx.xxx / 010.xxx.xxx.xxx (Different from fixture IP addresses)
NET mask: 255.0.0.0

Ethernet / DMX connection

Options "Ethernet/DMX" has to be selected from "Set Ethernet Mode" menu on the first fixture (connected to the network) in the fixture chain, next fixtures have standard DMX addresses.

Connect the Ethernet-input of the first fixture in the data chain with the network. Connect the DMX output of this fixture with the input of the next fixture until all fixtures are connected to the DMX chain.

Caution: At the last fixture, the DMX chain has to be terminated with a terminator. Solder a 120 Ω resistor between Signal (-) and Signal (+) into a XLR-plug and connect it in the DMX-output of the last fixture.

Example:

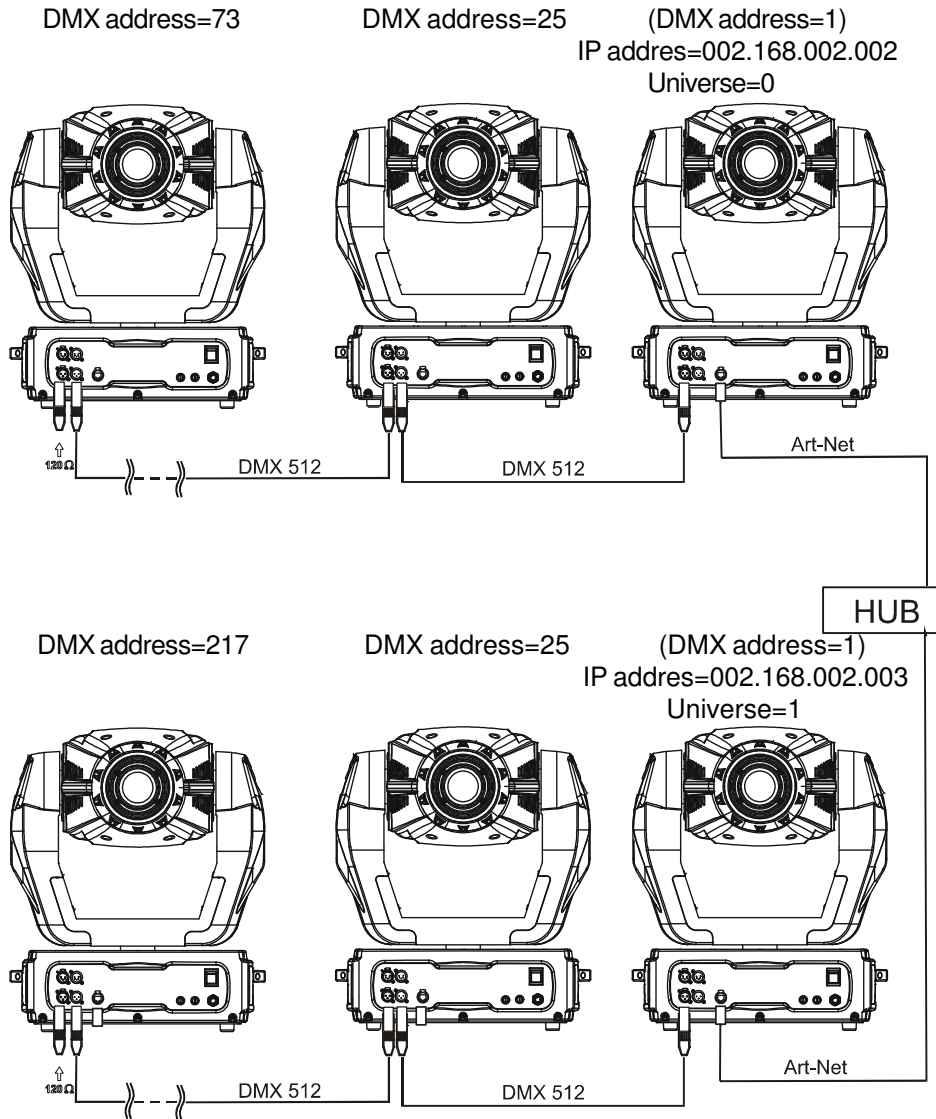

5.DMX Protocol-version 1.0

Mode/Channel				Value	Function	Type of control
1	2	3	4			
1	1	1	1	0-255	Pan Pan movement by 530°	proportional
2	2	2	2	0-255	Pan fine Fine control of pan movement	proportional
3	3	3	3	0-255	Tilt Tilt movement by 280°	proportional
4	4	4	4	0-255	Tilt fine Fine control of tilt movement	proportional
5	5	5	5	0	Pan/Tilt speed , Pan/Tilt time Max.speed (tracking mode)	step
				1-255	<i>P./T. speed- set Speed Mode in menu: P.t.Mo.</i> Speed from max. to min. (vector mode)	proportional
				1-255	<i>P./T. time - set Time Mode in menu: P.t.Mo.</i> Time from 0.1s to 25.5s. *	proportional
6	6	6	6	0-49	Power/Special functions Reserved	step
					<i>To activate following functions, stop in DMX value for at least 3 s and shutter must be closed at least 3 s. ("Shutter, Strobe" channel 25(18,27,20) must be at range:0-31 DMX). **</i>	
				50-59	Pan/Tilt speed mode	step
				60-69	Pan/Tilt time mode	step
				70-79	Blackout while pan/tilt moving	step
				80-89	Disabled blackout while pan/tilt moving	step
				90-99	Blackout while colour wheels moving	step
				100-109	Disabled blackout while colours wheel moving	step
				110-119	Blackout while gobo wheels moving	step
				120-129	Disabled blackout while gobo wheels moving	step
					<i>To activate following functions, stop in DMX value for at least 3 s.</i>	
				130-139	Lamp On,reset(total reset except pan/tilt reset)	step
				140-149	Pan/Tilt reset	step
150-159	Colour wheels reset	step				
160-169	Gobo wheels reset	step				
170-179	Dimmer/Strobe reset	step				
180-189	Focus/Zoom/Frost reset	step				
190-199	Iris/Prism reset	step				
200-209	Total reset	step				
210-229	Reserved	step				
230-239	Lamp Off	step				
240-255	Reserved	step				
		7	7	0-9	Pan/Tilt macro selection Disabled pan/tilt macro	step
				10-31	Reserved	step
				32-63	Figure of circle (from small to large)	proportional
				64-95	Figure of horizontal eight (from small to large)	proportional
				96-127	Figure of vertical eight (from small to large)	proportional
				128-159	Figure of rectangle (from small to large)	proportional
				160-191	Figure of triangle (from small to large)	proportional
				192-223	Figure of five-pointed star (from small to large)	proportional
				224-255	Figure of cross (from small to large)	proportional

Mode/Channel				Value	Function	Type of control
1	2	3	4			
				244-249	Random gobo selection by audio control (Set microphone sensitivity in menu "Personality")	step
				250-255	Auto random gobo selection from fast to slow	proportional
12		14		0-255	Fine static gobo positioning Fine positioning	proportional
13	10	15	12	0-3	Rotating gobo wheel <u>Index - set indexing on channel 14 (11/16/13)</u> Open/hole	step
				4-7	Gobo 1 (15030017)	step
				8-11	Gobo 2 (15040011)	step
				12-15	Gobo 3 (15020149)	step
				16-19	Gobo 4 (15020150)	step
				20-23	Gobo 5 (15020151)	step
				24-27	Gobo 6 (15020152)	step
				28-31	Gobo 7 (15020153)	step
					<u>Rotation - set rotation on channel 14 (11/16/13)</u>	
				32-35	Gobo 1	step
				36-39	Gobo 2	step
				40-43	Gobo 3	step
				44-47	Gobo 4	step
				48-51	Gobo 5	step
				52-55	Gobo 6	step
				56-59	Gobo 7	step
					<u>Shaking gobos from slow to fast</u>	
					<u>Index - set indexing on channel 14 (11/16/13)</u>	
				60-69	Gobo 1	proportional
				70-79	Gobo 2	proportional
				80-89	Gobo 3	proportional
				90-99	Gobo 4	proportional
				100-109	Gobo 5	proportional
				110-119	Gobo 6	proportional
				120-129	Gobo 7	proportional
					<u>Shaking gobos from slow to fast</u>	
					<u>Rotation - set rotation on channel 14 (11/16/13)</u>	
				130-139	Gobo 1	proportional
				140-149	Gobo 2	proportional
				150-159	Gobo 3	proportional
				160-169	Gobo 4	proportional
				170-179	Gobo 5	proportional
				180-189	Gobo 6	proportional
				190-199	Gobo 7	proportional
				200-201	Open/hole	step
				202-221	Forwards gobo wheel rotation from fast to slow	proportional
				222-223	No rotation	
				224-243	Backwards gobo wheel rotation from slow to fast	proportional
				244-249	Random gobo selection by audio control (Set microphone sensitivity in menu "Personality")	step
				250-255	Auto random gobo selection from fast to slow	proportional
14	11	16	13	0-255	Gobo indexing and rotation <u>Gobo indexing</u> Gobo indexing	proportional
				0	<u>Gobo rotation</u> No rotation	step
				1-127	Forwards gobo rotation from fast to slow	proportional
				128-129	No rotation	step
				130-255	Backwards gobo rotation from slow to fast	proportional

Mode/Channel				Value	Function	Type of control
1	2	3	4			
15		17		0-255	Gobo fine indexing Fine indexing	proportional
16	12	18	14	0-19 20-127 128-255 128-135 136-143 144-151 152-159 160-167 168-175 176-183 184-191 192-199 200-207 208-215 216-223 224-231 232-239 240-247 248-255	Prism Open position (hole) 3-facet rotating prism Prism/gobo macros Macro 1 Macro 2 Macro 3 Macro 4 Macro 5 Macro 6 Macro 7 Macro 8 Macro 9 Macro 10 Macro 11 Macro 12 Macro 13 Macro 14 Macro 15 Macro 16	step step step step step step step step step step step step step step step step step
17	13	19	15	0 1-127 128-129 130-255	Prism rotation No rotation Forwards rotation from fast to slow No rotation Backwards rotation from slow to fast	step proportional step proportional
18	14	20	16	0 1-179 180-189 190-211 212-233 234-255	Frost Open Frost from 0% to 100% 100% frost Pulse closing from slow to fast Pulse opening from fast to slow Ramping from fast to slow	step proportional proportional proportional proportional proportional
19		21		0-255	Frost fine Fine frost	proportional
20	15	22	17	0 1-179 180-191 192-219 220-247 248-249 250-251 252-253 254-255	Iris Open From max.diameter to min.diameter Closed Pulse effects with Iris blackout Pulse opening from slow to fast Pulse closing from fast to slow Random pulse opening (fast) Random pulse opening (slow) Random pulse closing (fast) Random pulse closing (slow)	step proportional step proportional proportional step step step step
21		23		0-255	Iris fine Iris fine	proportional

Mode/Channel				Value	Function	Type of control
1	2	3	4			
22	16	24	18	0-39 40-79 80-127 128-169 170-219 220-255	Zoom <i>Zoom without focus corection</i> Zoom 15° Zoom 18° Zoom 22° <i>Zoom with focus corection ***</i> Zoom 15° Zoom 18° Zoom 22°	step step step step step step
23	17	25	19	0-255	Focus Coarse focus	proportional
24		26		0-255	Focus fine Fine focus adjustment	
25	18	27	20	0-31 32-63 64-95 96-127 128-143 144-159 160-191 192-223 224-255	Shutter,Strobe Shutter closed, <u>Lamp power reduced after 10s to 400W</u> Shutter open , <u>Full lamp power</u> Strobe-effect from slow to fast(max. 15 flashes/s) Shutter open, <u>Lamp power reduced to 400 W</u> Opening pulse in sequences from slow to fast Closing pulse in sequences from fast to slow Shutter open, <u>Electronic strobing"ZAP" from slow to fast (from 7 to 33 flashes/s)</u> Random strobe-effect from slow to fast Shutter open, <u>Full lamp power</u> Note: <u>underlined characters</u> -Colorspot 575E AT only	step step proportional step proportional proportional proportional proportional step
26	19	28	21	0-255	Dimmer Dimmer intensity from 0% to 100%, (In range 0-9 DMX,lamp power reduced to 400 W after 10 s - Colorspot 575E AT only)	proportional
27		29		0-255	Dimmer fine Dimmer intensity fine	proportional

* Short times are not used for long tracks(e.g. 0.5s for track 0-255 DMX).Times are restricted by mechanical parameters of the fixture.

** The switch-functions have priority to the equivalent functions in menu "Personality"but the setting by DMX is not saved to the memory(after switching the fixture on,the setting from menu "Personality" is loaded and after that can by changed with DMX value on the channel 6).

DMX protocol	menu "PerS"
50-59 Pan/Tilt speed mode	P.t.Mo.--->SP.Mo.
60-69 Pan/Tilt time mode	P.t.Mo.--->ti.Mo.
70-79 Blackout while pan/tilt moving	A.blc.-->P.t.M.-->On
80-89 Disabled blackout while pan/tilt moving	A.blc.-->P.t.M.-->Off
90-99 Blackout while colour wheels moving	A.blc.-->Col.M.-->On
100-109 Disabled blackout while colour wheels moving	A.blc.-->Col.M.-->Off
110-119 Blackout while gobo wheels moving	A.blc.-->Gob.M.-->On
120-129 Disabled blackout while gobo wheels moving	A.blc.-->Gob.M.-->Off

*** The function improves the image on the wall if the zoom changes(its effect is the best for gobos from rot. gobo wheel and for distance = 6 m)

6. Controller mode

The fixtures are individually addressed on a data link and connected to the controller. The fixtures respond to the DMX signal from the controller.

6.1 DMX addressing

There are 512 available channels on DMX link. Every fixture on DMX link must have a DMX start address, which is defined as the first channel from which the fixture will respond to the controller.

If you set, for example, for the ColorSpot 575E AT the start address to channel 28, the ColorSpot 575E AT will use the channels from 28 to 54 for control (if Mode 1 is selected from "DMX Preseting" menu).

Please, be sure that you don't have any overlapping channels in order to control each ColorSpot 575E AT correctly and independently from any other fixture on the DMX data link.

If two, three or more ColorSpot 5750 AT are addressed similarly, they will work similarly.

Controlling:

After having addressed all ColorSpot 575E AT, you may now start operating these via your lighting controller.

Note: After switching on, the ColorSpot 575E AT will automatically detect whether DMX 512 data is received or not. If there is no data received at the DMX-input, the display will start to flash with actually address.

This situation can occur if:

- the 3(or 5) pin XLR plug (cable with DMX signal from the controller) is not connected with the input of the ColorSpot 575E AT
- the controller is switched off or defective, the cable or connector is defective or the signal wires are swap in the input connector.

6.2 Remotely controllable functions

Lamp

The ColorSpot 575E AT is to be operated with a Philips MSR 575W/2 lamp.

A relay inside of the ColorSpot 575E AT allows you to switch on and off the lamp via the control panel or via your DMX-controller without affecting the rest of the lighting.

Note: It is also important to note, that the discharge lamp is cold restrike types, that means, that they have to be cold before re-striking. For this reason, you have to wait at least 5 minutes after having switched off the lamp before you can switch it back on again. If you try to switch On the lamp within 5 minutes after having switched it Off, the ColorSpot 575E AT will store this information and automatically ignite the lamp when the 5 minutes period has expired.

Colour 1-wheel

This wheel contains 9 dichroic filters and an open.

Colour 2-wheel

This wheel contains 8 replaceable 'SLOT&LOCK' dichroic filters + open. The colour-wheel can be positioned between two adjacent colours in any position. It is also possible to rotate the colour-wheel continuously at different speeds ("Rainbow effect" in both directions).

Static gobo-wheel

The static gobo wheel includes 9 replaceable 'SLOT&LOCK' metal gobos + open, gobo-shake function possible.

Rotating gobo-wheel

The rotating gobo-wheel includes 7 gobos rotating in both directions, indexable, replaceable 'SLOT&LOCK' dichroic glass gobos + open position.

3-facet rotating prism

The 3-facet replaceable prism rotating in both directions at different speeds.

Iris

Motorized iris for different beam diameter, variable pulse effects.

Frost

Separate, variable frost.

Focus,Zoom

Motorized focus enables the beam to be focused anywhere on stage at different beam angles 15°,18°,22°,provided by the special zoom.

Dimmer/Shutter/Strobe

Smooth 0 - 100 % dimming is provided by the combined mechanical dimmer/shutter unit. This unit may also be used for strobe effect (1 - 10 flashes per second)

Fans

By the Control Board using the "**Fan Modes**" function you can choose the 2 types of the fan speed operating modes.

8.Control menu map

Default settings=**Bold print**

Default settings=**Bold print**

Fixture Address

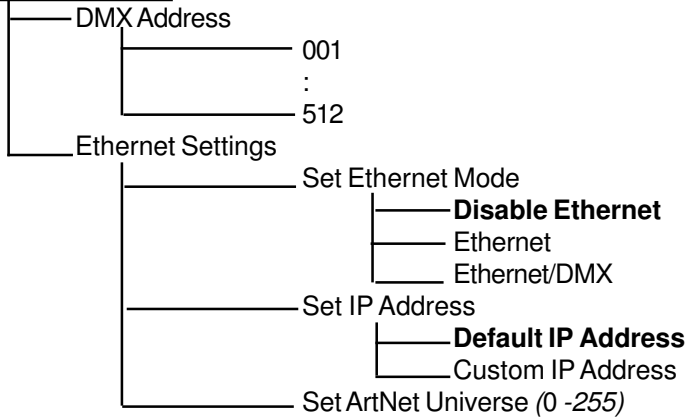

Fixture information

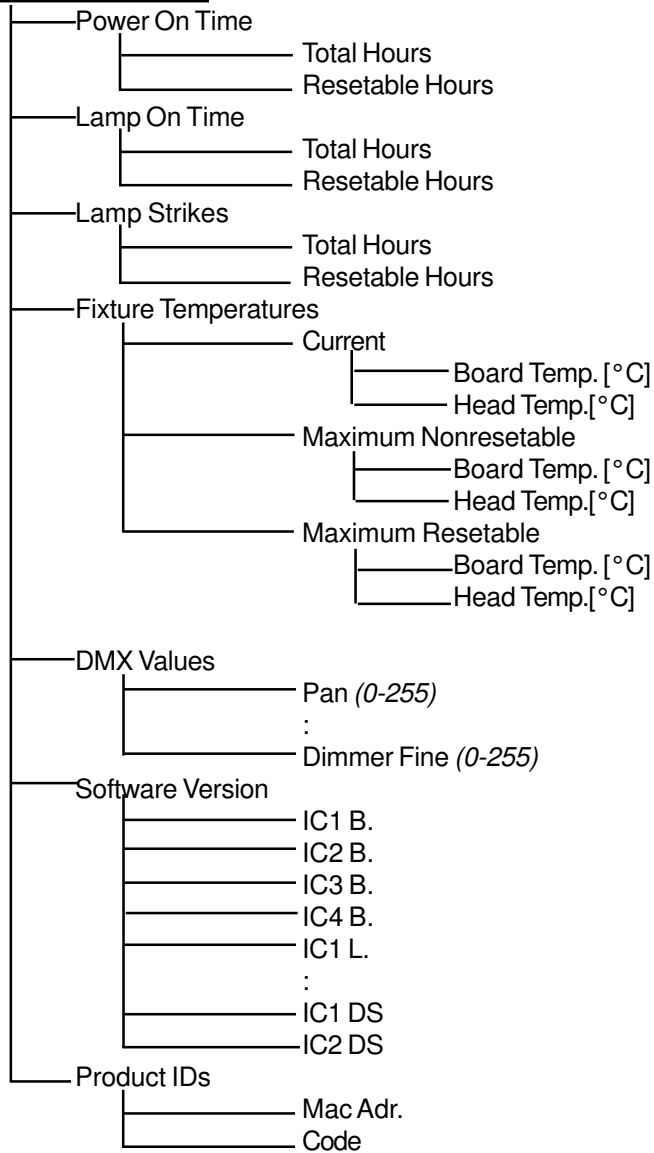

Personality

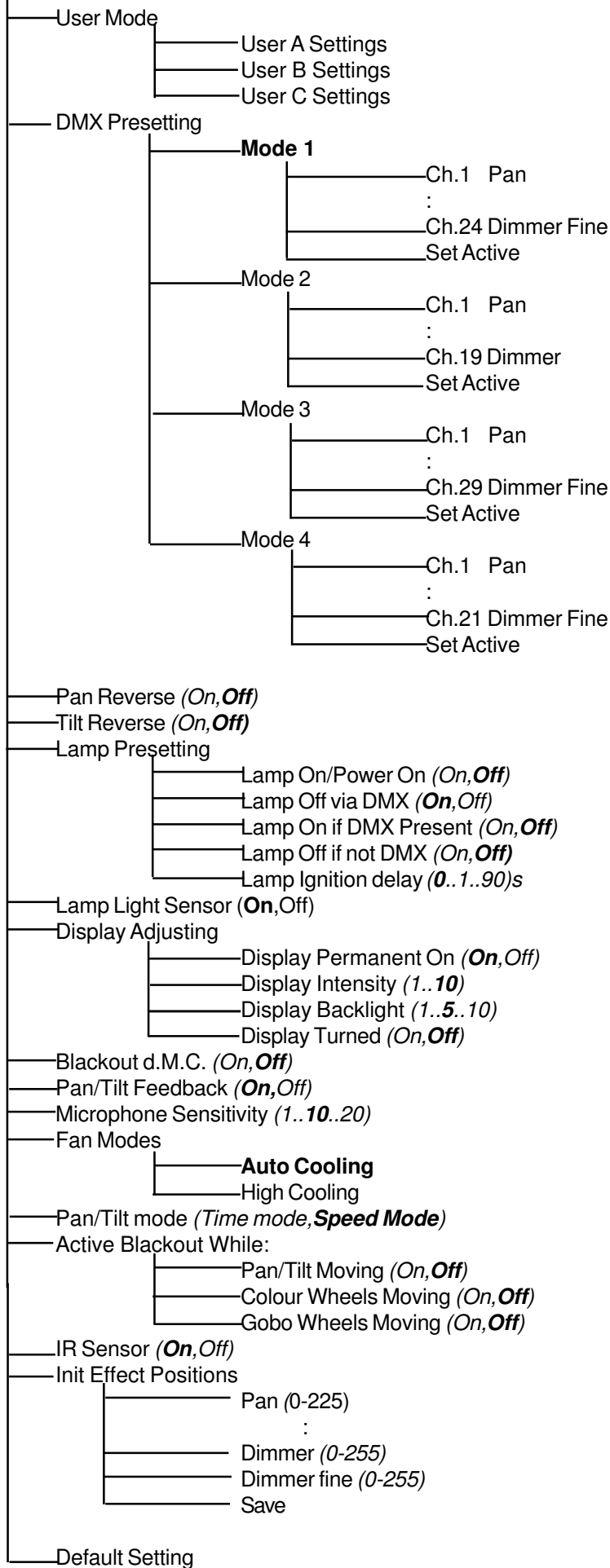

Lamp On/Off (*On, Off*)

Test sequences

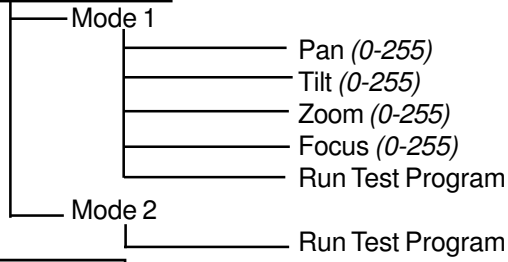

Manual Mode

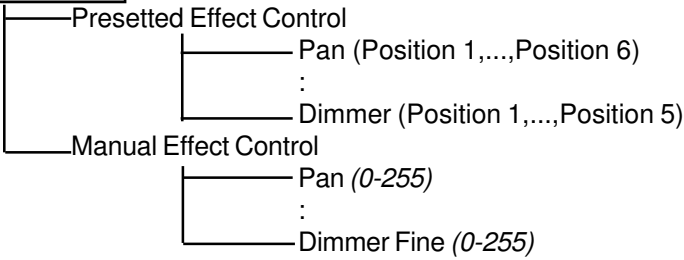

Stand- alone setting

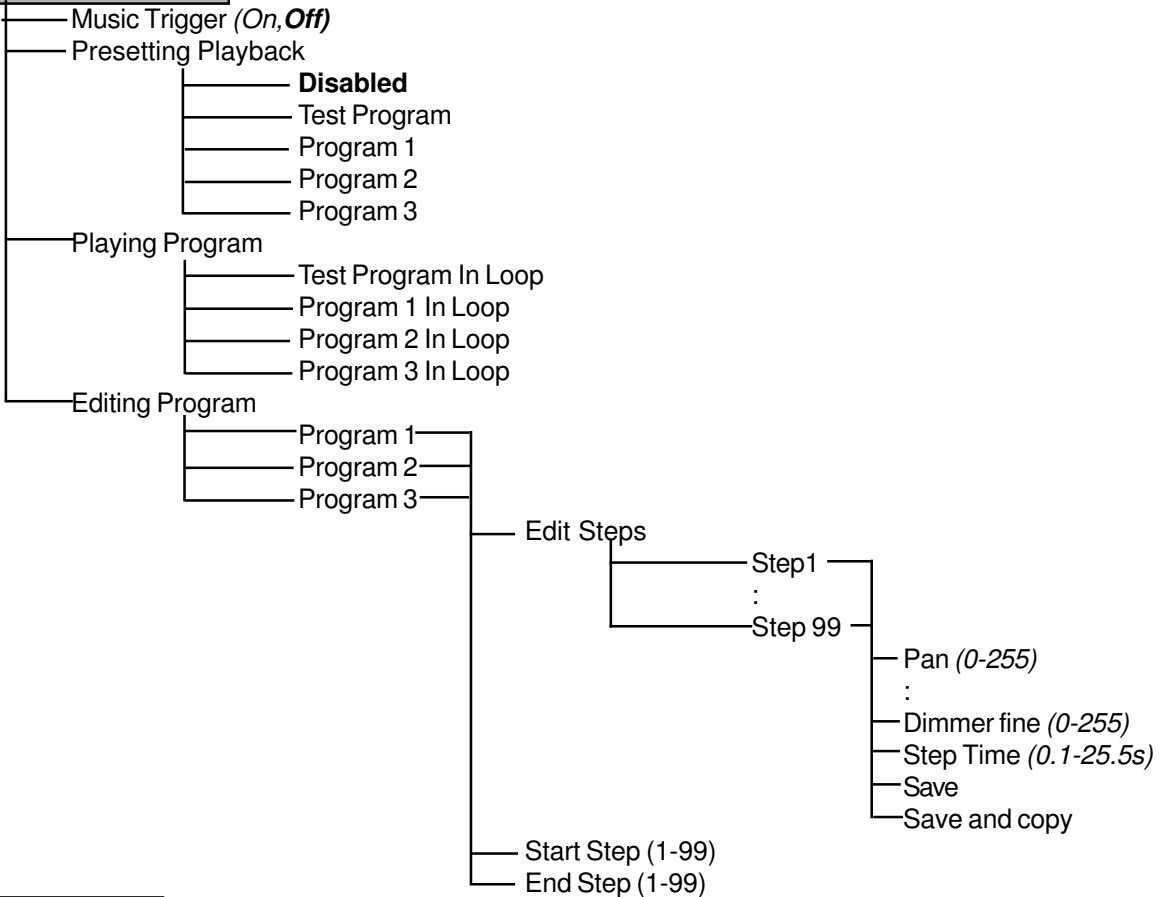

Reset function

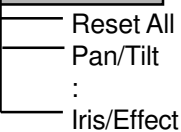

Special functions

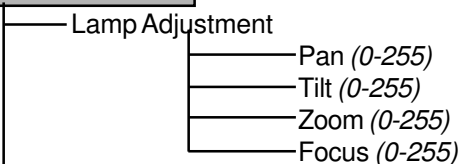

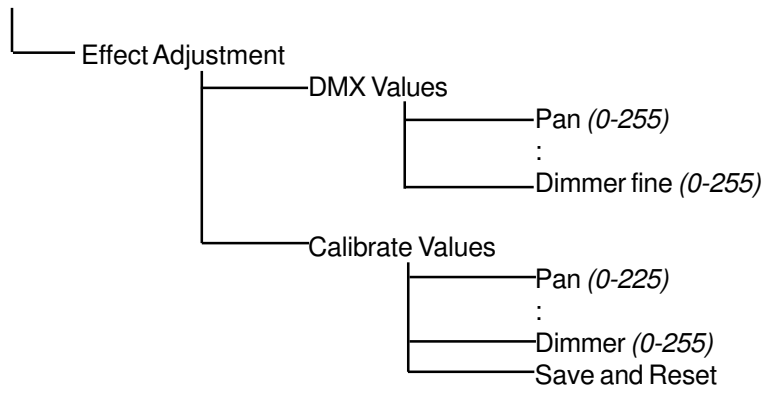

9. Control menu

The control panel situated on the front panel of the base offers several features. You can simply set the DMX address, read the number of the lamp or unit hours, switch On and Off the lamp, run test, make a reset and also use many functions for setting fixture behaviour.

Control elements on the control board:

[RNS] encoder wheel-moves between menu items on the the same level, scrolls between values.

[ESC] button-leaves menu without saving changes

[ENTER] button-enters menu,confirms adjusted values and leaves menu

After switching the fixture on,the display shows the initial screen:

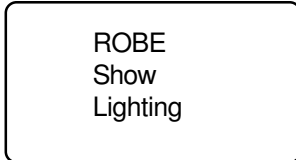

Press [ENTER],the display shows current address:

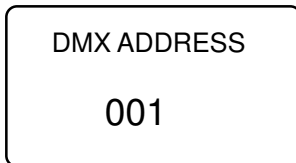

The main menu of the control panel is accessed by pressing [ENTER] button.To browse through the menu, rotate [RNS] wheel. To select a function or submenu,press [ENTER] button.Presetted options are displayed negative.

9.1 Fixture Address

Use this menu to set the DMX address.

DMX Address --- Select this submenu to set DMX start address.

Ethernet Settings --- Select this submenu to set the fixture for Ethernet operating.

Set Ethernet Mode --- Select this submenu to select Ethernet operating mode:

Disable Ethernet --- disables network operating.

Ethernet --- Data are received to the Ethernet input of the fixture - every fixture from fixture chain has to be connected to the network.

Ethernet/DMX --- Data go from Ethernet input "through" the fixture to the DMX output of the fixture- it is possible to connect the next fixture to DMX output and to make a DMX chain.

Set IP Address --- Select this submenu to set IP address.IP address is the Internet protocol address.The IP uniquely identifies any node (fixture) on a network.There can't be 2 fixtures with the same IP address on the network!

Default IP Address --- Presetted IP address,you can edit only first number of IP address (2 or 10) e.g.**002.019.052.086**.

Custom IP Address --- The option enables edit all numbers of IP address e.g.**002.019.052.086**.

To set the custom IP address:

- 1.Select "Custom IP Address" and press [ENTER].
- 2.Use RNS wheel to set the first number of IP address
- 3.Press [ENTER] to move on the second number of IP address
- 4.Repeat steps 2 and 3 for the third and the fourth number of IP address.If you want to return back on the previoully edited number,press [ESC].

Set ArtNet Universe --- Select this submenu to set a Universe (0-255).The Universe is a single DMX 512 frame of 512 channels.

8.2 Fixture informations

Use this menu to read an useful information about the fixture.

Power On Time --- Select this submenu to read the number of operation hours.

Total Hours --- The function shows the total number of the operation hours since the ColorSpot 575E AT has been fabricated.

Resetable Hours --- The function shows the number of the operation hours that the ColorSpot 575E AT has been powered on since the counter was last reset. In order to reset this counter to 0, press [ENTER] twice.

Lamp On Time --- Select this submenu to read the number of the operation hours with the lamp on.

Total Hours --- The function shows the total number of the operation hours with the lamp on since the ColorSpot 575E AT has been fabricated.

Resetable Hours --- The function shows the number of the operation hours with the lamp on that the ColorSpot 575E AT has been powered on since the counter was last reset. In order to reset this counter to 0, press [ENTER] twice.

Lamp Strikes --- Select this submenu to read the total number of the lamp strikes.

Total Hours --- The function shows the total number of the lamp strikes since the ColorSpot 575E AT has been fabricated.

Resetable Hours --- The function shows the number of the lamp strikes since the counter was last reset. In order to reset this counter to 0, press [ENTER] twice.

Fixture Temperatures --- Select this submenu to read the temperatures of the fixture:

Current - Select this function to read the current temperatures of the fixture inside (Board Temp., Head Temp.)

Maximum nonresetable - The function shows the max. temperatures of the fixture inside (Board Temp., Ambient Temp., Near Lamp Temp.) since the ColorSpot 575E AT has been fabricated.

Maximum resetable - The function shows the maximum temperatures of the fixture inside (Board Temp., Ambient Temp., Near Lamp Temp.) since the respective counter was last reset. In order to reset desired counter to 0, press [ENTER] twice.

Measurement points:

Board Temp. - temperature on the main board in the fixture base. Temperatures below 66°C are not critical. 66°C and more lead to the lamp being switched off and the fixture goes to "low power mode". Before switching the lamp on again (after 5 minutes), run a total fixture reset.

Head Temp. - temperature of the head inside. Temperatures below 83°C are not critical. 83°C and more lead to the lamp being switched off and the fixture goes to "low power mode". Before switching the lamp on again (after 5 minutes), run a total fixture reset.

Please note that the ambient temperature should not exceed 40°C.

DMX Values --- Select this function to read DMX values of each channel received by the fixture.

Product IDs --- Select this function to read the MAC address or fixture code.

Software Version --- Select this function to read the software version of the fixture modules:

IC1 B. --- Main processor on the main board in the fixture base

IC2 B. --- Pan processor on the main board in the fixture base

IC3 B. --- Tilt processor on the main board in the fixture base

IC4 B. --- EEPROM on the main board in the fixture base

IC1 L. --- Processor 1 in the left arm of the fixture

IC2 L. --- Processor 2 in the left arm of the fixture

IC1 R. --- Processor 1 in the right arm of the fixture

IC2 R. --- Processor 2 in the right arm of the fixture

IC1 DS --- Display processor on the display module in the fixture base

IC2 DS --- Memory on the display module in the fixture base

9.3 Personality

Use this menu to to modify ColorSpot 575E AT operating behavior.

User mode --- ColorSpot 575E AT allows you to recall up to 3 user settings. After switching the fixture on for the first time, the **User A settings** are active. All changes made in "Personality" menu, "Fixture Address" menu and Music Trigger and Presetting Playback functions from "Stand-alone setting" menu are saved to the **User A settings**. If you now set the **User B settings** active, from this moment these changes are saved to the **User B settings**. After switching the fixture off and on, the User B setting is active. In this way you may use 3 fixture operating behaviour.

User A Settings --- The function recall the user A settings.

User B Settings --- The function recall the user B settings.

User C Settings --- The function recall the user C settings.

Pan Reverse --- Select this function to invert the pan movement.

Tilt Reverse --- Select this function to invert the tilt movement.

DMX Presetting --- Select this function to set desired effects assigning to the channels. Please refer to the chapter "DMX protocol" for detail description.

Please refer to the chapter "DMX- protocol" for detail description.

Lamp Presetting --- Select this menu to change the lamp "behaviour".

Lamp On/Power On --- Select this function to turn the lamp on automatically after switching the fixture on.

Lamp Off via DMX --- Select this function to switch off the lamp via DMX.

Lamp On if DMX Present --- This function allows you to strike the lamp automatically after 26 seconds if DMX signal is present on the data link. If the ignition is unsuccessful (e.g. lamp is too hot), the fixture will try to ignite the lamp after next 26 s. This process will repeat until the lamp lights.

Lamp Off if not DMX --- This function allows you to switch Off the lamp automatically after 2 minutes if DMX signal is missing on the data link.

Lamp Ignition Delay --- This function allows you to set the time delay (0-90s) before the lamp will be ignited. This setting will not affect starting the lamp direct from the control panel (menu "Lamp On/Off").

Lamp Light Sensor --- Select this function to switch the lamp light sensor on or off. The option "On" is for the standard operation.

Important: The option "Off" is for "emergency operation" only if the lamp light sensor is defective and you will wait for a service intervention! If the lamp light sensor is switched off and at switching the lamp on the electronics will still try to ignite the lamp until it shines (even when the lamp is damaged or absent), on this account some electronics parts could be damaged!

Display Adjusting --- This function allows you to change the display settings.

Display Permanent On --- This function allows you to keep the display on or to turn off automatically 2 minutes after last pressing any button (or a wheel movement) on the control panel.

Display Intensity --- Select this function to adjust the display intensity (1-min., 10-max.).

Display Backlight --- Select this function to adjust the display backlight (1-min., 10-max.).

Display Turned --- Select this function to turn the display by 180°.

Blackout d.M.C. --- Select this function to enable the blackout during the head movement correction (if the moving head lost its right pan/tilt position for a short moment).

Pan/Tilt Feedback --- This function allows to return the moving head to the required pan/tilt position after changing the position by external force (e.g. by stroke).

Be careful, the Pan/Tilt Feedback OFF is not the standard operation and the head of the fixture can be damaged!

Note: If the feedback was switched off, the pan/tilt-position is changed by an external force and the feedback is switched on again, the moving head might not to be synchronized with the DMX signal. You have to make a reset in order to synchronize the moving head with the DMX signal.

Microphone Sensitivity --- Select this function to adjust the microphone sensitivity from 1 (maximum) to 20 (minimum). If the sensitivity is correctly adjusted, the mark  will appear (blinking in the bass beat.)

Fan Modes --- By using this function you can choose 2 types of the fan speed operating modes.

Auto Cooling --- The fans automatically raise their speed in order to control inside temperature of the lighting, if the temperature inside increases about certain level (the low fan speed reduces the cooling of the lighting). This cycle can repeat several times until the temperature inside is on a suitable level.

High Cooling --- The cooling fans work on max. speed (max. cooling). This mode we recommend for high ambient temperature (30 °C and more).

Pan/Tilt mode --- Use this menu to set the character of the pan/tilt movement.

Time mode --- Pan and tilt will move with different speeds and they will come at the same time to end point (pan and tilt sets its optimal speed).

Speed Mode --- Pan and tilt will move with the same speed as adjusted by the channel 5 (Pan/Tilt speed). E.g. pan will come to the end point and wait for tilt, which has longer track.

Active Blackout while: --- Use this function if you wish to close the light output during effect changes.

Pan/Tilt Moving --- This function closes the light output during pan/tilt changes.

Colour Wheel Moving --- This function closes the light output during colour wheel 1/wheel 2 changes.

Gobo Wheels Moving --- This function closes the light output during static gobo wheel / rotating gobo wheel changes.

IR Sensor --- Select this function to switch on/off infra-red remote control.

Init Effect Positions --- Select this function to set all effects to the desired positions. After switching the fixture on (if DMX is not connected), all effects will move to this init positions.

Note: If you operate e.g. 27 channels pre-setting (Mode 1) and you adjust DMX values for channels which are not included in this mode, you will not be able to change these effects from the controller !

Default Settings --- Select this option to reset all fixture personalities to the default values.

9.4 Lamp On/Off

Use this option in order to switch on/off the lamp. It is also important to note, that the lamp is cold restrike type, that means, that it has to be cold before striking.

9.5 Test sequences

Use this menu to run a special demo-test sequences without an external controller, which will show you some possibilities of using ColorSpot 575E AT.

Mode 1 --- This mode is suitable for projections on the wall, ceiling or ground without any head movement.

Mode 2 --- This mode uses all ColorSpot 575E AT functions including pan/tilt movement and therefore is good for a complete introduction of the fixture.

9.6 Manual mode

Presettled Effects --- Select this menu to call up presettled positions of channel effects.

Manual Effect control --- Select this menu to control channels by control elements on the control board.

9.7 Stand-alone setting

Use this menu to set options for stand-alone mode as a selection of the playing program, programming and modifying current programs.

Music Trigger --- Select this function to enable the sound control of the running programs via the built-in microphone.

Presetting Playback --- This function allows you to select the program which will be played in the stand-alone mode after switching the fixture on. Selected program will be played continuously in a loop.

Disabled --- The option disables "Presetting playback" function.

Test Program --- The option will start built-in test program.

Program 1 --- The option will start created program No. 1

Program 2 --- The option will start created program No. 2

Program 3 --- The option will start created program No. 3

Note: If the fixture operates in the controller mode (DMX controller is connected) and any program from this menu is selected ,in this case the fixture will not respond to the DMX controller after switching on and will play selected program.

Playing program --- Select this menu to run a built-in program or the 3 freely-programmable programs in a loop.

Test Program In Loop --- The option starts built-in test program.

Program 1 In Loop --- The option starts created program No. 1

Program 2 In Loop --- The option starts created program No. 2

Program 3 In Loop --- The option starts created program No. 3

Select the program you wish and press [ENTER]. The selected program starts running. By Pressing [ENTER] again is possible to pause the program running.

Editing Program --- Select this menu to edit or create the program. The ColorSpot 575E AT has one built-in program and the 3 free programs, each up to 99 steps. Each program step has a step time. Step time-the time, during which effects last in the current step.

Procedure:

1. Select the program you want to edit ("Program 1" - "Program 3") and press [ENTER].

2. Select "Edit Steps" menu and press [ENTER].

3. Select the desired program step ("Step 01" - "Step 99") and press [ENTER].

4. Select the desired item and press [ENTER]. Now you can edit DMX value for selected item:

"Pan" - a coarse pan, value 0-255

"Pan Fine" - a fine pan, value 0-255

"Tilt" - a coarse tilt, value 0-255

"Tilt Fine" - a fine tilt, value 0-255

"Pan/Tilt Speed" - a speed of pan/tilt movement, value 0-255

"Spec. Func." - a special functions, lamp on/off, reset, value 0-255

"Pan/Tilt Macro" - a pan/tilt macro, value 0-255

"P./T. Macro Speed" - a pan/tilt macro speed, value 0-255

"Colour Wheel 1" - a colour wheel 1, value 0-255

"Colour 1 Fine" - a colour wheel 1-fine positioning, value 0-255

"Colour Wheel 2" - a colour wheel 2, value 0-255

"Colour 2 Fine" - a colour wheel 2-fine positioning, value 0-255

"Static Gobo Wheel" - a static gobo wheel, value 0-255

"Static Gobo Fine" - a fine positioning, value 0-255

"Rot. Gobo Wheel" - a rotating gobo wheel, value 0-255

"Rot. Gobo Indexing" - a rot. gobo - coarse indexing and rotation, value 0-255

"Rot. Gobo F. Indexing" - a rot. gobo - fine indexing, value 0-255

"Prism" - a prism and prism/gobo macros, value 0-255

"Prism Rotation" - a prism rotation, value 0-255

"Frost" - a frost, value 0-255

"Frost Fine" - a fine frost movement, value 0-255

"Iris" - an iris, value 0-255

"Iris Fine" - a fine iris movement, value 0-255

"Zoom" - a zoom, value 0-255

"Focus" - a focus, value 0-255

"Focus Fine" - a fine focus movement, value 0-255

"Shutter/Strobe" - a shutter and strobe, value 0-255

"Dimmer" - a dimmer intensity-coarse, value 0-255

"Dimmer Fine" - a dimmer intensity-fine, value 0-255

5. Select "Save" or "Save and Copy" and press [Enter] to confirm adjusted values:

"Save" - saving the current prog. step

"Save and Copy" - saving and copying the current prog. step to the next prog. step.

6. Go on next prog. step and repeat this procedure (steps 4 and 5).

After creation the program, you can simply reduce its length (by changing the start/end steps) using the "Start Step" and "End Step" menu.

9.8 Reset functions

The ColorSpot 575E AT can be reset totally or by function modules. Select relevant function to run a reset:

Reset All --- This function enables the fixture to index all effects and return to their standard positions.

Pan/Tilt --- This function resets pan and tilt.

Colour System --- This function resets colour wheels.

Gobo System --- This function resets static and rotating gobo wheels.

Dimmer/Strobe --- This function resets dimmer/strobe module.

Focus/Zoom/Frost --- This function resets focus, zoom and frost.

Iris/Prism --- This function resets iris and rot.prism.

9.9 Special functions

Use this menu for special services like adjusting lamp or adjusting effects.

Lamp Adjustment --- This function can be used when you make the fine adjustment of the lamp. If you select this function, all effects will be canceled, shutter will be opened and the dimmer intensity will be set onto 100%. By using the options "**Pan, Tilt, Zoom, Focus**" you can focus the light on a flat surface (wall) and perform the fine lamp adjustment.

Effect Adjustment --- By this function you can calibrate and adjust the effects to their standard/right positions. Disconnect the DMX controller from the fixture and select "**DMX Values**" menu. The display shows step by step effects by which you can adjust the fixture to the required position before the function calibration. When the positioning is finished, select "**Calibrate Values**" and press [ENTER]:

1. Calibration via the control board

Select desired effect, press [ENTER] and adjust its right value (0 - 255). This can be repeated for each calibrated effect if it is required. When the calibration is finished, it is necessary to use the "**Save and Reset**" function to write the calibration values to the memory and to make a reset in order to check the newly adjusted positions of the calibrated effects.

List of the calibrated effects:

Colour Wheel 1	Static Gobo wheel	Rot. Gobo Indexing
Colour Wheel 2	Rot. Gobo Wheel	Iris
		Dimmer

2. Calibration via the DMX controller

Connect the DMX controller to the fixture. Now you can calibrate the selected effect by your controller.

Effect	Mode 1	Mode 2	Mode 3	Mode 4
Colour wheel 1	channel 28	channel 20	channel 30	channel 22
Colour wheel 2	channel 29	channel 21	channel 31	channel 23
Static gobo wheel	channel 30	channel 22	channel 32	channel 24
Rot. gobo wheel	channel 31	channel 23	channel 33	channel 25
Rot. gobo indexing	channel 32	channel 24	channel 34	channel 26
Iris	channel 33	channel 25	channel 35	channel 27
Dimmer	channel 34	channel 26	channel 36	channel 28

After having calibrated required effects, use the "**Save and Reset**" function to write the calibration values to the memory and to make a reset in order to check the newly adjusted positions of the calibrated effects.

10. Low power mode

This mode omits fixture reset after switching the fixture on and lowers motor powers of the fixture. "Low power mode" is useful in special cases, e.g. if the fixture is in a flight case and you want to set its DMX address without taking it out from the case. To enter "Low power mode":

Press and hold [ENTER] and at the same time switch on the Power switch. The following message appears:

Really Skip Initial Reset?

Escape/Enter

Press [ENTER] to activate "Low power mode" without fixture reset. Now you can set features and behaviour of the fixture by using "Fixture Address" menu and "Personality" menu. It is expected that this mode will be exited by switching the fixture off, but if you want to go directly to "normal operation mode", execute any fixture reset.

Note: All motors (except pan and tilt motors) in "Low power mode" are deactivated and switching the lamp on from the control panel is blocked.

11. Error and information messages

Occured errors during fixture operation are signaled by warning icon on the display:



Press [ESC] to see the current error messages. Description of error messages:

Active Lamp Timer

This message appears if you try to switch on the lamp within 5 minutes after having switched it off (the lamp is too hot). The message will appear on the display if the lamp doesn't ignite within 28 seconds. The ColorSpot 575E AT will store this information and automatically ignite the lamp when the 5 minutes period has expired.

Caution: The message is disabled if the lamp light sensor (function "Lamp Sensor" in menu Personality) is switched Off.

Lamp Error

The ignition of the lamp is seven times unsuccessful (the "Active Lamp Timer" message appeared six times before), and the display shows "Lamp Error", meaning that the lamp could be damaged or even missed or there could be a failure on the ignitor or ballast.

Please place or replace the lamp and contact your dealer if the situation was not caused by the lamp.

Caution: The message is disabled if the lamp light sensor (function "Lamp Sensor" in menu Personality) is switched off.

Lamp Sensor Error

This message informs the lamp light sensor is failed.

Caution: The message is disabled if the lamp sensor (function Lamp Sensor in menu Personality) is switched Off.

Overheated-Lamp Off

This message informs that the fixture head is overheated and the lamp was switched off by its temperature sensor

Short Power Error

This message will appear if the fixture was shortly disconnect from the main.

Supply Frequency Error

This message will appear if the frequency of the main is not standard 50 or 60 Hz.

The following error messages are separated into 2 groups:

xxxx xxxx Error 1 (e.g. *Colour Wheel 1 Error 1*)

xxxx xxxx Error 2 (e.g. *Colour Wheel 1 Error 2*)

There are some possible reasons of faults:

Message

xxxx xxxx Error 1

Characteristic fault

Magnetic sensor is permanently On (e.g. leading wire is short-circulated, defective stepping motor, defective control circuit on the PCB)

xxxx xxxx Error 1/xxxx xxxx Error 2
(together)

Magnetic sensor is permanently Off (e.g. leading wire is disconnected, defective magnetic sensor, missing magnet), defective stepping motor

Colour Wheel 1 Error 1 (Colour Wheel 1 Error 2)

The messages will appear after the reset of the colour wheel if this wheel is not located in the default position.

Colour Wheel 2 Error 1 (Colour Wheel 2 Error 2)

The messages will appear after the reset of the colour wheel if this wheel is not located in the default position.

Rot.Gobo Wheel Error 1 (Rot.Gobo Wheel Error 2)

The messages will appear after the reset of the gobo wheel if this wheel is not located in the default position.

Rot. Gobo Index. Error 1 (Rot. Gobo Index. Error 2)

The messages will appear after the reset of the gobo wheel 1 if the rotating gobo wheels are not located in the default positions.

Static Gobo Error 1 (Static Gobo Error 2)

The messages will appear after the reset of the gobo wheel if this wheel is not located in the default position.

Iris Error 1 (Iris Error 2)

The messages will appear after the reset of the iris if the iris lamellas are not located in the default positions.

Pan Error 1 (Pan Error 2)

The messages will appear after the reset of the yoke if the yoke is not located in the default position.

Tilt Error 1 (Tilt Error 2)

The messages will appear after the reset of the head if the head is not located in the default position.

12. Technical specifications

Power supply:

Voltage:.....100/120/208/230/240V AC, 50/60Hz ~
 Live Fuse:.....T 6.3A@230V, T 10A@120V
 Neutral Fuse:.....T 6.3A@230V,T 10A@120V
 Power consumption:.....760 VA

Lamp:

Philips MSR 575/2, 95V/575W GX-9,5

Optical System:

- High luminous-efficiency glass reflector
- focus lens and multistep zoom lenses system
- beam angles:15°,18°,22°
- All lenses are anti-reflection coated

Beampath:

Lamp: MSR 575W/2

15° radiation angle

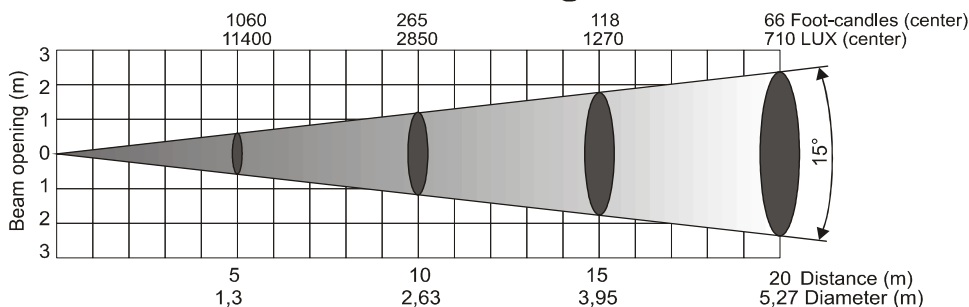

18° radiation angle

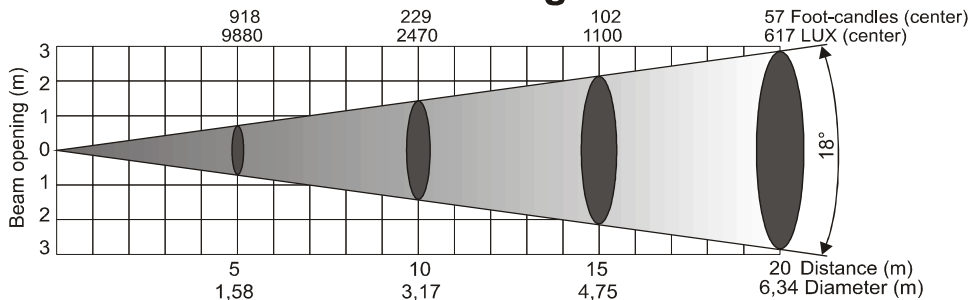

22° radiation angle

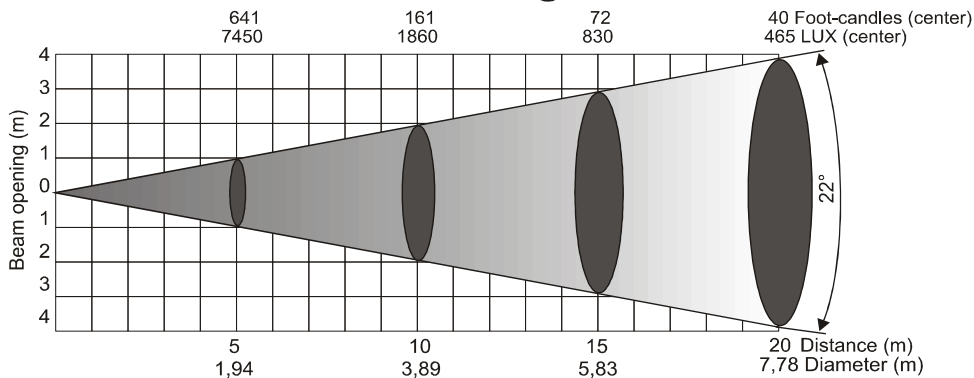

Lamp: MSR 575W/2

15° radiation angle with frost

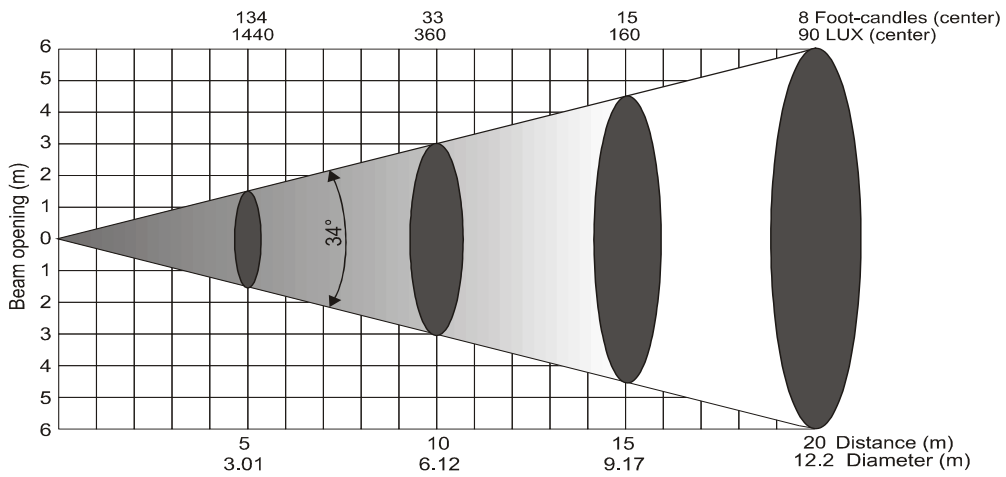

18° radiation angle with frost

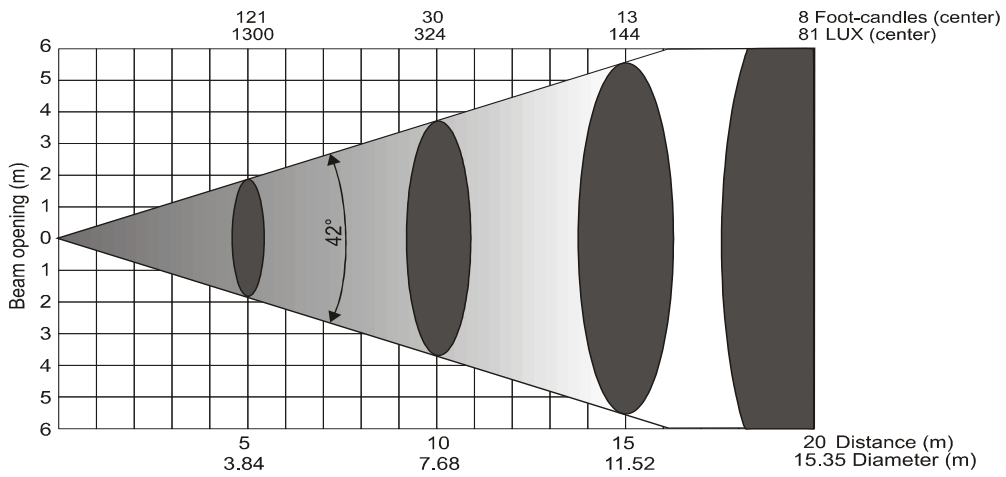

22° radiation angle with frost

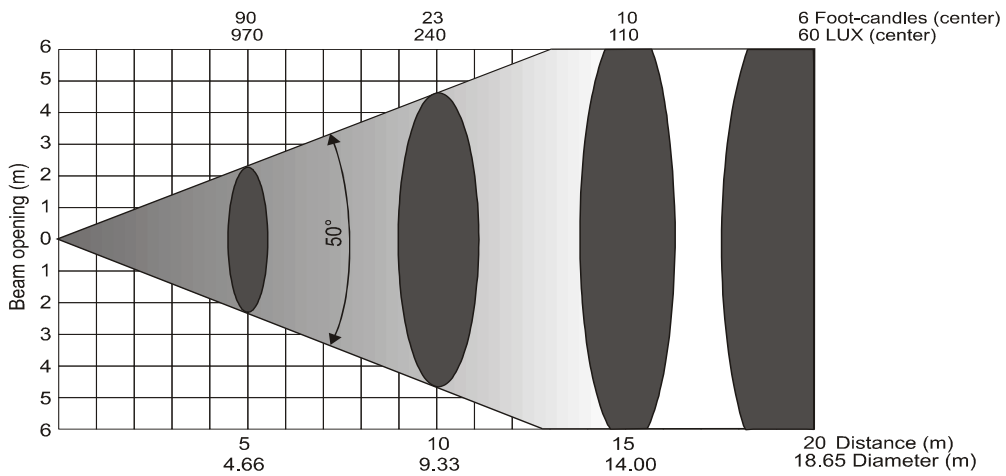

Colours:

Colour wheel 1:

- 9 dichroic filters + open

Colour wheel 2:

- 8 replaceable 'SLOT&LOCK' dichroic filters (including 3200 K and UV filter) + open

Static gobo wheel:

- 9 replaceable 'SLOT&LOCK' metal gobos plus an open position, outside diameter=26.9mm, image diameter=22.5mm, aluminium, thickness=0.5mm

Rotating gobo wheel:

- 6 dichroic glass gobos and one glass gobo rotating in both directions at different speeds
- Gobo indexing
- Rotating gobo-wheel cont. rotation
- Multicolor dichroic glass gobos: outside diameter=26.8mm, thickness=1.1 mm, high temperature borofloat or better glass, image diameter=22 mm
- Glass gobo: outside diameter=26.8mm, max. thickness=4mm, high temperature borofloat or better glass
- All rotating gobos are easily replaceable

Strobe:

- Strobe effect with variable speed (max. 15 flashes per second)

Dimmer:

- Smooth dimmer from 0 - 100 %

Prism/Frost filter:

- 3-facet-prism (rotating in both directions at different speeds) can be replaced with another prism

Frost filter:

- Separate, variable frost filter

Focus/Zoom:

- Remotely controllable via DMX
- Motorized multi-step zoom with three different apertures (15°, 18°, 22°)

Iris:

- Motorized (steplessly adjustable) iris for different beam diameters

Motors:

- 16 high quality stepping-motors controlled by microprocessors

Electronics:

- Control via control panel with graphic LCD display and 2 buttons/ rotating wheel
- Readout fixture and lamp usage, receiving DMX values, temperature, etc
- Built-in analyzer for easy fault finding, error messages
- Remotely switching of the lamp
- Built-in demo sequences
- Black-out while head moving or gobo/color changing
- Silent fans cooling, remotely controllable speed of fans
- Self-resettable thermo-fuse
- Digital serial input DMX-512
- 4 control-channels presettings (27, 19, 29, 21 control channels)

Pan/Tilt

- Pan movement range 530°
- Tilt movement range 280°

- Max.Pan speed 157.27°/sec.
- Max.Tilt speed 108.95°/sec.
- Pan/tilt control accuracy: 0.00415°/0.00415°
- 16 bit movement resolution
- Automatic Pan / Tilt position correction
- Remotely controllable speed of pan/tilt movement for easy programming
- Movement control:tracking and vector

Rigging

- Stands directly on the floor
- Mounts horizontally or vertically with 2 Omega brackets
- 2 truss orientation
- Safety chain/cord attachment point

Temperatures

- Maximum ambient temperature : 40° C
- Maximum housing temperature : 80° C

Minimum distances

- Min.distance from flammable surfaces: 0,7m
- Min.distance to lighted object: 2,0m

Dimensions(mm)

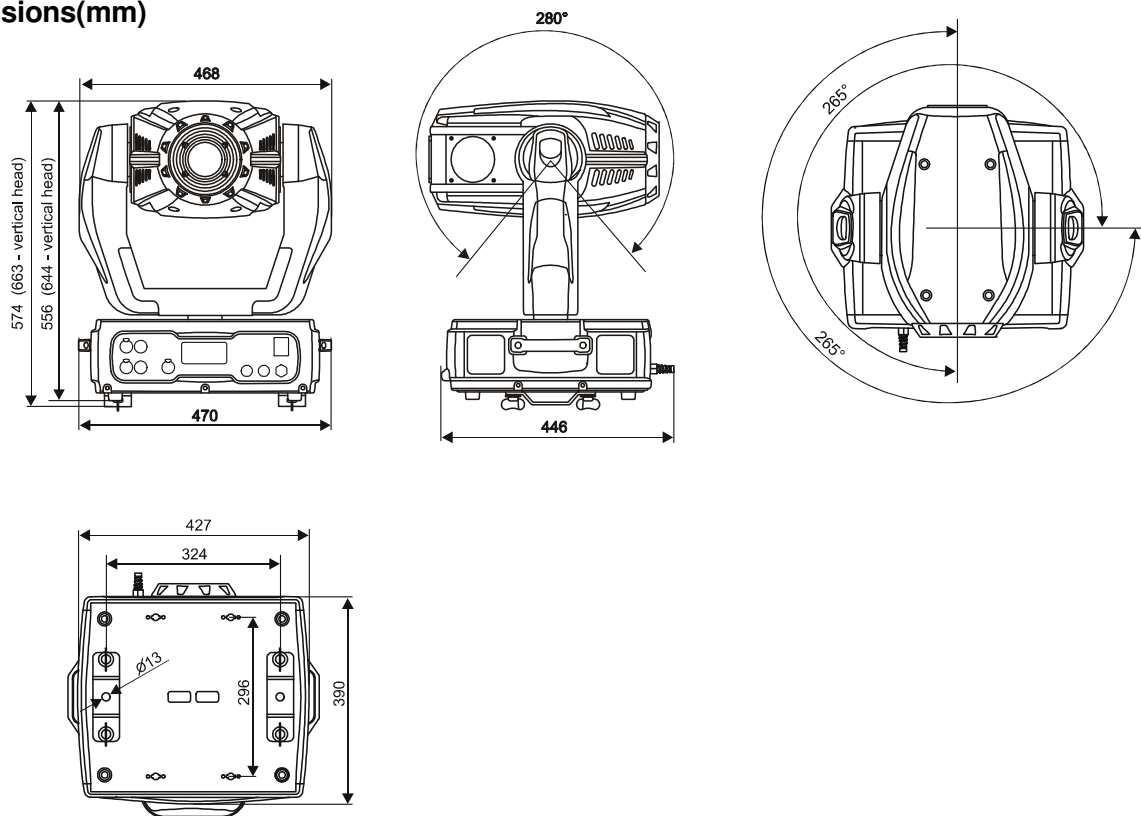

Weight (net):

26kg (electronic ballast)

Accessories

- Accessories gobo-set 12.....15050021
- Omega holder (2 pieces).....99010420

Optional accessories:

Remote control IR (No.13050419)

13. Maintenance and cleaning

It is absolutely essential that the fixture is kept clean and that dust, dirt and smoke-fluid residues must not build up on or within the fixture. Otherwise, the fixture's light-output will be significantly reduced. Regular cleaning will not only ensure the maximum light-output, but will also allow the fixture to function reliably throughout its life. A soft lint-free cloth moistened with any good glass cleaning fluid is recommended, under no circumstances should alcohol or solvents be used!

DANGER!
***Disconnect from the mains before starting any
maintenance work***

The front objective lens will require weekly cleaning as smoke-fluid tends to building up residues, reducing the light-output very quickly. The cooling-fans should be cleaned monthly.

The gobos may be cleaned with a soft brush. The interior of the fixture should be cleaned at least annually using a vacuum-cleaner or an air-jet.

The dichroic colour-filters, the gobo-wheel and the internal lenses should be cleaned monthly.

There are no serviceable parts inside the device except for the lamp and the fuse.

Please refer to the instructions under "Fitting/Exchanging the lamp".

Maintenance and service operations are only to be carried out by authorized dealers.

Replacing the fuse

If the lamp burns out, the fine-wire fuse of the device might fuse, too. Only replace the fuse by a fuse of same type and rating.

Before replacing the fuse, unplug mains lead.

Procedure:

- 1) Unscrew the fuseholder on the rear panel of the base with a fitting screwdriver from the housing (anti-clockwise).
- 2) Remove the old fuse from the fuseholder.
- 3) Install the new fuse in the fuseholder.
- 4) Replace the fuseholder in the housing and fix it.