

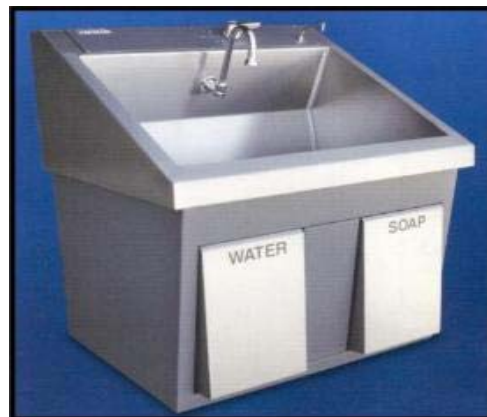

SURGICAL SCRUB SINKS

INSTALATION-OPERATION-MAINTENANCE

USER MANUAL



California OSHPD
Pre-approved

Mac Medical
820 S Mulberry St.
Millstadt, IL 62260
(618) 476-3550 phone
(618) 476-3337 fax

November 2007



WARNINGS AND CAUTIONS

Following is a list of the safety precautions, which must be observed when operating this equipment. WARNINGS indicate the potential for danger to personnel, and CAUTIONS indicate the potential for damage to equipment. These precautions are repeated (in whole or in part), where applicable, throughout the manual. It is important to review these precautions before using the equipment.

WARNING-INJURY HAZARD:

REPAIRS AND ADJUSTMENTS should be only attempted by experienced mechanics fully acquainted with this equipment. Use of inexperienced, unqualified persons to work on the equipment or the installation of unauthorized parts could cause serious personal injury or result in costly damage.

TWO PEOPLE ARE REQUIRED to mount the sink to the wall.

WARNING-BURN HAZARD:

DO NOT CHANGE Temperature settings on thermostatic mixing valve, unless you are a trained mechanic.

ANY REPAIR or modification of mixing valve may affect the high temperature setting. The installer must check operating temperature before sink is back in operation.

CAUTION-POSSIBLED EQUIPMENT DAMAGE:

When cleaning the sink, use a non-abrasive polish. Rub in a back and forth motion in the same direction of the surface grain.



GENERAL SPECIFICATIONS

1. MATERIAL:

SINK BASIN: 14 GAUGE, 304 STAINLESS STEEL

SINK SKIRT: 18 GAUGE, 304 STAINLESS STEEL

2. ALL PLUMBING ½" COPPER OR BRASS PIPE.

THE SINK WILL BE FURNISHED WITH IN LINE CHECK VALVES ON SUPPLY LINES.

3. UTILITY REQUIREMENTS:

* COLD WATER: 20 TO 50 PSIG 70 DEG F MAX

* HOT WATER: 20 TO 50 PSIG 120 DEG F TO 140 DEG F

* IT SHALL BE THE CUSTOMERS RESPONSIBILITY TO INSURE BY USE OF PRESSURE REGULATORS OR OTHER MEANS THAT MAXIMUM SPECIFIED PRESSURES ARE NOT EXCEEDED.

* WATER LINES SHOULD BE FLUSHED CLEAN BEFORE WATER CONNECTIONS ARE MADE.

* IT SHALL BE THE CUSTOMERS RESPONSIBILITY TO ENSURE THAT WATER SUPPLIES ARE PROPERLY PROTECTED FOR INTERNAL CROSS CONNECTION CONTROL IN ACCORDANCE WITH LOCAL BUILDING AND PLUMBING REQUIREMENTS.

* IT SHALL BE THE CUSTOMERS RESPONSIBILITY TO ELIMINATE WATER HAMMER CONDITIONS SHOULD THEY OCCUR IN THE SERVICE PIPING.

4. POWER REQUIREMENTS (FOR SENSOR OPERATIONS):

120 VOLT, 60 Hz, SINGLE PHASE, 15 AMP GFIC PROTECTED ELECTRICAL OUTLET (BY OTHERS), INSTALLED PER LOCAL BUILDING CODES.

5. NET WEIGHT OF SINK IS 130 LBS SINGLE BASIN, 230 LBS DOUBLE BASIN, 320 LBS TRIPPLE BASIN.

6. SINK IS "UL" AND "CUL" RECOGNIZED.

7. SINK IS CALIFORNIA "OSHPD" PRE-APPROVED WHEN MOUNTED ON A STRUCTUALLY SOUND WALL.



Installation

1. Carefully uncrate the scrub sink.

The mounting hardware is under the sink, secured to the shipping materials. Be sure to remove all hardware before discarding packaging.

2. Install "Z" bracket(s) to wall.

Recommended mounting specifications shown to right.

Note: For wall-mounted units the wall structure must be capable of supporting the load. The in-wall support system is recommended for installation in areas where wall strength is insufficient. (See Next Page)

3. Install sink support brackets.

Hint: With the help of an assistant hang the sink from the "Z" brackets before drilling for the wall support brackets. With the sink in place mark the proper position for the brackets. Remove sink and finish installation of brackets.

4. Check supply and waste terminal location.

Be sure all connections are safely accessible and in proper working condition.
(See Supply Location Diagram/Page 5)

NOTE: For proper sink operation the hot water temperature must be **120 degrees F**.

5. Install the soap spout. (See page 7)

6. Install the sink body.

With the help of an assistant slide the sink back down over the "Z" bracket until it locks securely into place.

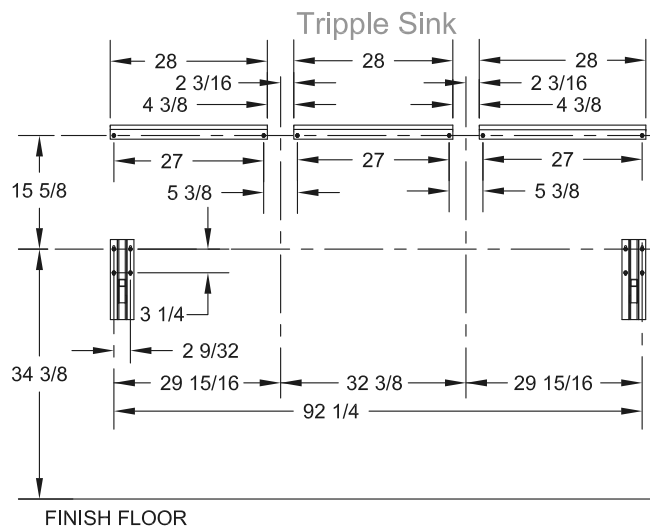
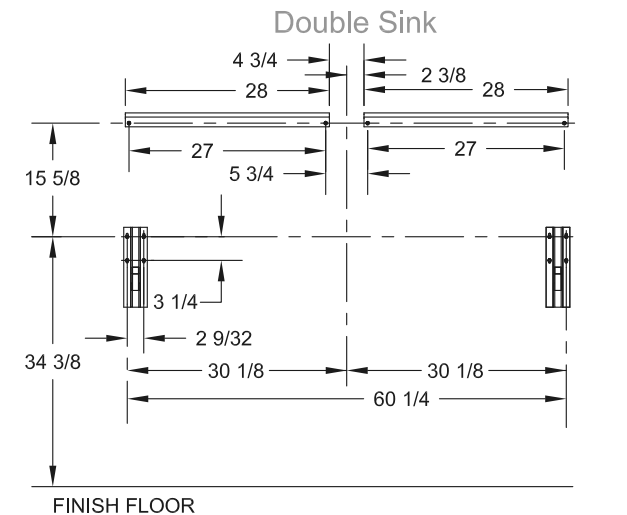
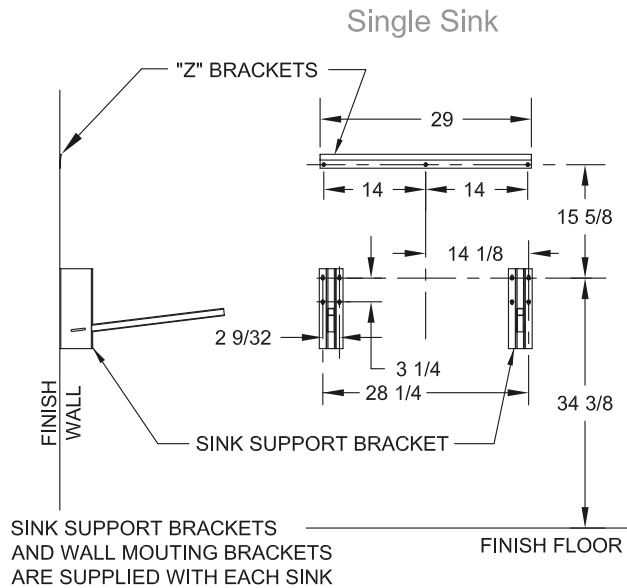



Installation

In-Wall Sink Support System

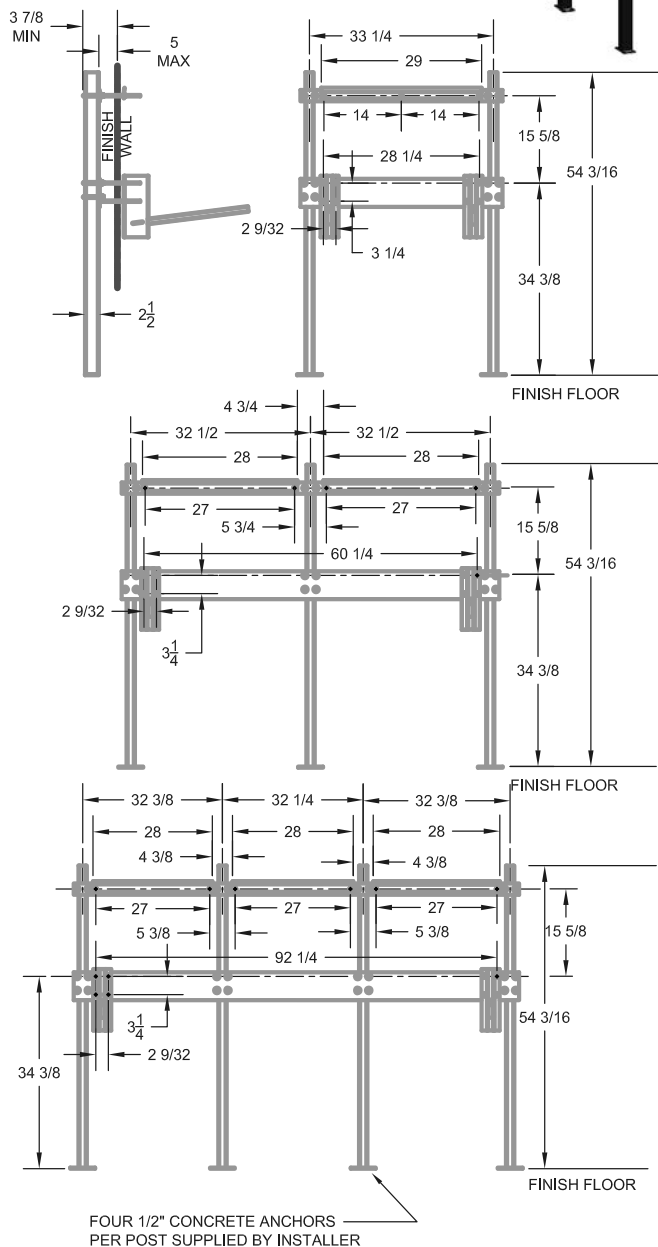

Plumbing Access

(Manual Knee Operated Sinks Only)

Knee panels must be removed for plumbing access. The panels are released by pressing up on the lever in the center of the bottom of the panel. While pressing the lever pull out on the panel in order to access the hinge pin levers.

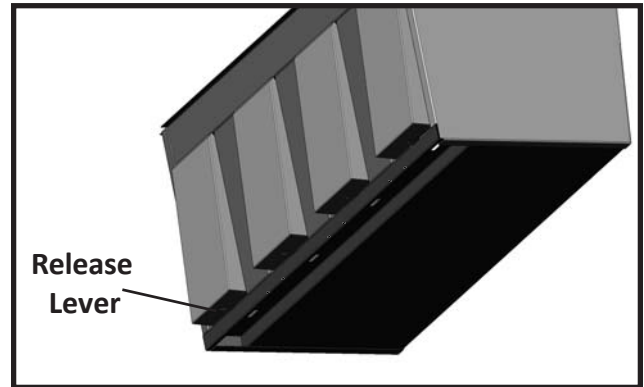

While holding the panel out, slide the hinge pin levers toward the center of the panel and completely remove the panel. The remaining panels in the face of the cabinet are also removable. These panels are held by two bolts inside the cabinet at the base of the panel.

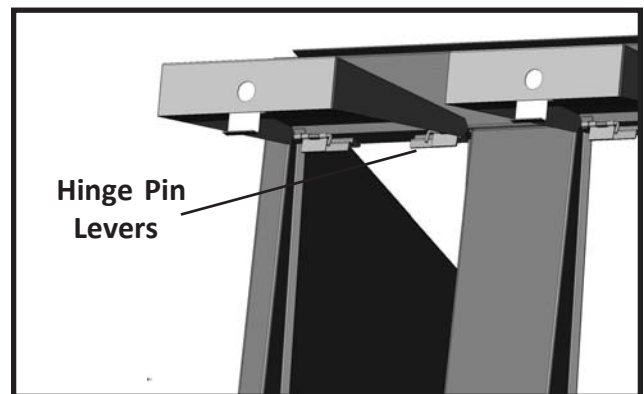

Water Pressure

After the plumbing installation is complete the water pressure can be adjusted to avoid excess splash. The pressure can be controlled by adjusting the (flow control valve). (See plumbing diagram) to find the correct location of the valve depending on sink type.



Plumbing Diagram

Infra Red Self-Activated Sinks

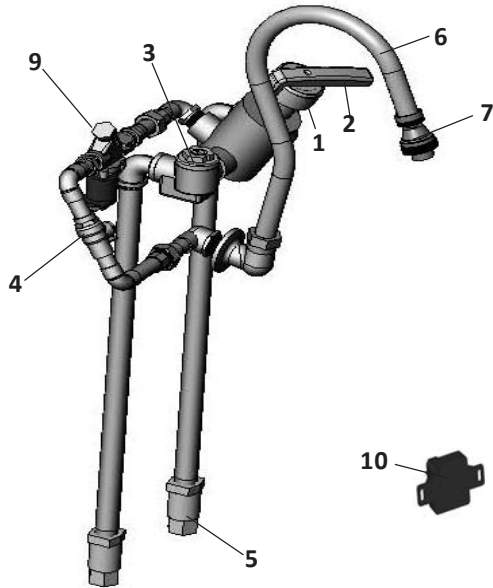

Manual Knee Operated Sinks

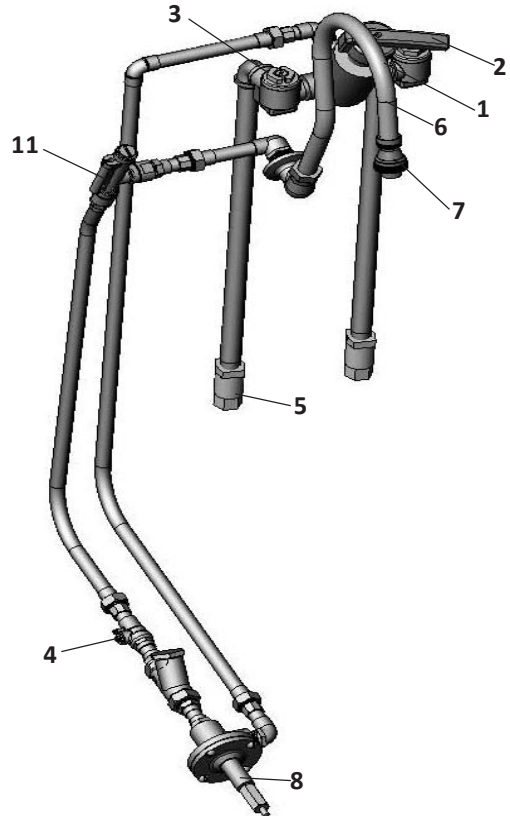

Water Supply Locations

For double and triple sinks all dimensions are equal to diagram, relative to sink basin.

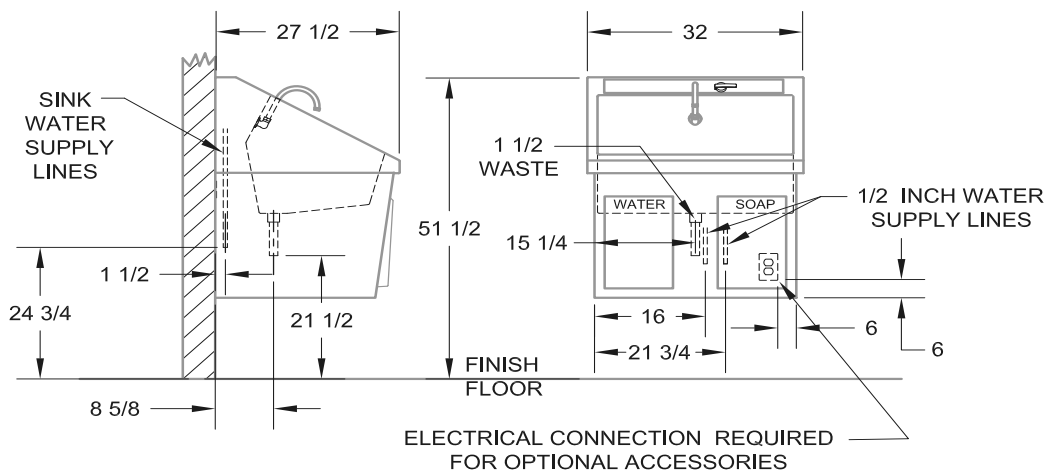



Replacement Parts

Item No.	Description	Part No.
1	Thermostatic Mixing Valve	S0009
2	Valve Handle	S0010
3	Check Stop Strainer	S0011
4	Flow Control Valve	S0024
5	Check Valve	S0131
6	Spout	S0132M
7	Swivel Aerator	S0032
8	Knee Operated Water Valve	S0029
9	Solenoid Valve For Infra Red	S0013
10	Infra Red Sensor	S0012
11	Timer Solenoid	S0130
	Knee Operated Soap Pump	S0028
	Thigh Operated Soap Pump	S0030
	Soap Dispensor Spout	S0041
	Sink Dividers	S0034
	Scrub Timers	S0050



Infra Red Controls

Installation

The sink is supplied with a 24V Power transformer that connects to a standard duplex outlet. (110/120 V outlet required). Plug the transformer into the outlet. A red led will flash in the sensor window. It is important to not interrupt the sensor beam until the light turns off.

Infra red sensor centered on spout on each sink bay

Optional thigh operated soap pump

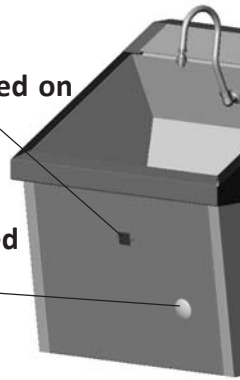

Operation

The sensors are pre set and equipped with a logic board. The sensor determines the range during the initialization period. (The time after initial power until the light turns off. Approximately 5 minutes) the range is approximately 12-14" in front of the sensor and is 25 degree at peak.

During the initialization period, the sensor allows for fixed objects that may be within the sensors range. The sensors are equipped with a 2 second on/off delay and no time out feature. This prevents the sink from turning on when walking past at a normal pace and no time out allows for an uninterrupted scrub.

Soap Dispenser Install

To prevent damage the soap dispenser is stored inside the rear of the sink cabinet during shipping. The dispenser head should be installed before hanging the sink.

Spout during shipping

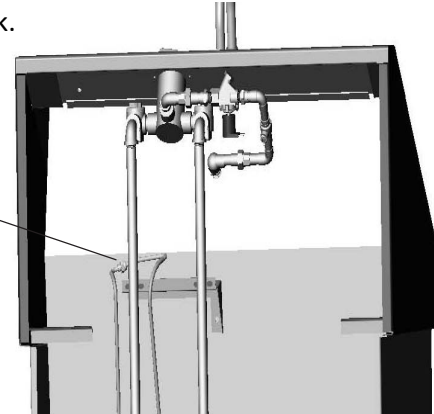

Spout installed

To Install:

Remove the nut from the spout. Feed the spout through the hole in the header from inside the cabinet and reinstall the nut. Attach soap tubing as seen below.

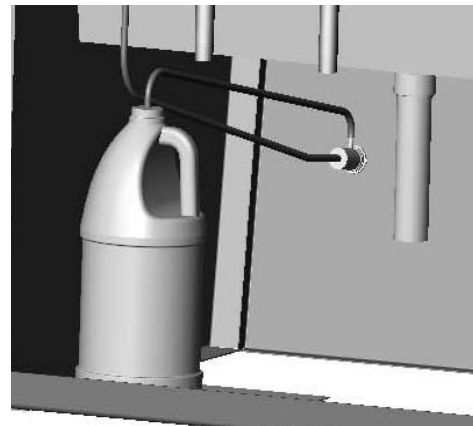

POWERS™

TECHNICAL INSTRUCTIONS

HydroGuard™ T/P Series e420

Under-the-Counter Thermostatic Tempering Valve

DESCRIPTION

Hydroguard Series e420 Under-the-Counter thermostatic tempering valves are designed for all applications where the temperature of generated hot water must be controlled for safe, economic use. A powerful advanced thermal actuator quickly senses and compensates for temperature fluctuations induced by water temperature and pressure changes in the supply line.

Rugged construction features cast brass body and corrosion-resistant internal components for years of dependable, trouble-free service. Hex socket makes temperature adjustment quick and easy.

For restricted access control, the Series e420 UTC valve can be housed in a stainless-steel or white baked enamel steel cabinet and can be packaged with solenoid valve(s) checkstops or other accessories common to Powers' cabinet supply offering.

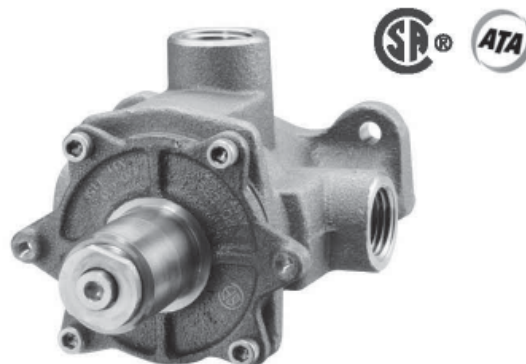

Model e420RB0SS000

Shown without checkstops. Checkstops recommended.

SPECIFICATIONS

Connections	1/2" NPT Inlets and 1/2" NPT Top Outlet
Capacity (without checkstops)525 gpm [19.9 L/min]* (±0.25 gpm [0.95 L/min])
Maximum Hot Water Supply Temperature	190°F [88°C]
Minimum Hot Water Supply Temperature (not applicable to low temperature hot water valves)	5°F [2.8°C] above set point
Maximum Operating Pressure	125 psig [862 kPa]
Temperature Ranges:	
ASSE 1016 Type T	65-115°F [18-46°C]
ASSE 1016 Type T/P	90-110°F [32-43°C]
Maximum Static Pressure	125 psig [862 kPa]
Minimum Flow and Pressure Differential:	1 gpm [3.79 L/min]
Compliant	ASSE 1016-T/P
Certified	CSA B125
Shipping Weight5 lbs. [2.3 kg]

The Hydroguard Series e420 Under-the-Counter valves meet the above operating conditions as stated in ASSE 1016 T/P (45 psi pressure differential, hot water supply between 140°–180°F [60°–82°C], cold water supply less than 70°F [21°C]).

If your operating conditions vary from those stated in the standard, performance may vary as well. Consult your local sales representative or a Powers factory engineer to discuss your specific application. All Powers Under-the-Counter thermostatic mixing valves perform to the requirements of standards ASSE 1016 and CSA B125.

* At 45 psi differential [310 kPa], with hot water supply between 140°–180°F [60–82°C] and 50/50 mix.

OPERATION

Hot and cold water enter respective ports in the valve and mix in a chamber containing an advanced thermal actuator (refer to cutaway view). This actuator controls the valve assembly.

Rotating the adjustment handle repositions the shuttle in the cartridge assembly to produce the desired temperature. If the hot or cold supply water temperature or pressure changes, the thermal actuator will contract or expand. This movement repositions the shuttle to maintain the desired temperature.

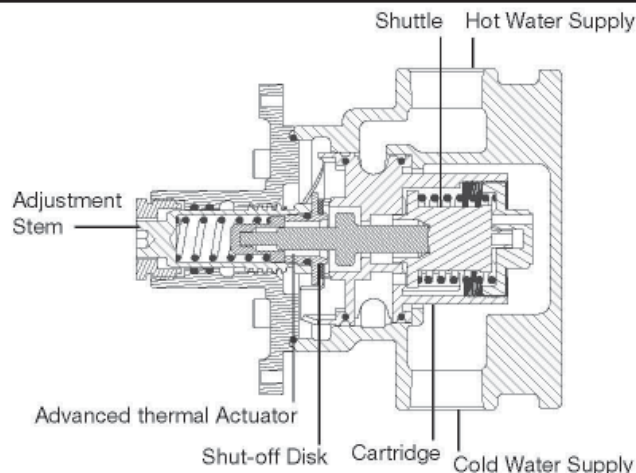

SAFETY AND PERFORMANCE GUIDELINES

Adherence to these guidelines and recommendations promotes safe product use and ensures proper valve performance.

1. Thermostatic water mixing valves are control devices which must be cleaned and maintained on a regular basis. Powers specifies periodic maintenance at least once a year or immediately after any changes are made to the plumbing system. Although annual cleaning is recommended, frequency of cleaning depends on quality of local water conditions. Refer to Preventive Maintenance below for recommended cleaning procedure.
2. Quick closing valves may cause damage to the mixing valve by creating shock waves. When the e420 Hydroguard supplies tem-

pered water to self-closing and/or solenoid valves, Powers recommends use of a shock absorber (Powers Part No. 460-353) on the discharge line. This protects the e420 Hydroguard valve from damage.

3. Locate the valve as close as possible to outlet fixture to avoid waste of energy and water except in applications where the valve is used as a primary mixing valve to supply an entire building.
4. Correct valve sizing affects valve and system performance; under or over-sizing of the mixing valve(s) can cause poor operation and possibly injury.

CALIFORNIA PROPOSITION 65 WARNING

WARNING: This product contains chemicals known to the State of California to cause cancer and birth defects or other reproductive harm. (California law requires this warning to be given to customers in the State of California.)

For more information: www.watts.com/prop65

PREVENTIVE MAINTENANCE

Every Six Months: Check and adjust the temperature setting (see instructions below).

Every Twelve Months:

1. Shut off water supply.
2. Open up checkstops (if any).
3. Clean strainers (if any) and check for free movement of checkstop poppet.
4. Replace seals if cracked, cut, or worn.
5. Reassemble.
6. Adjust stem to desired temperature.

TROUBLESHOOTING

1. **The flow of water is less than desired...**
 - valves upstream from supply not fully open
 - low supply pressures
 - accumulation of lime deposits in hot water pipes, restricting the flow of hot water
 - checkstops not fully open
 - clogged strainer screens in the checkstops
 - clogged cartridge
2. **Flow of water is completely shut off...**
 - valves upstream from supply completely closed
 - failure of cold water supply pressure (the e420 Hydroguard is designed to shut off on a cold water supply failure)
 - checkstops completely closed
3. **Flow is untempered hot or cold water...**
 - accumulation of lime deposits in hot water pipes, restricting the flow of hot water
 - thermostatic actuator failure; replace with new thermostatic actuator
 - hot and cold water supplies are connected to the wrong ports
4. **Maximum temperature specified for the e420 Hydroguard cannot be obtained...**
 - accumulation of lime deposits in hot water pipes, -restricting the flow of hot water
 - hot water supply temperature is too low
5. **Variable discharge temperature occurs...**
 - extreme pressure variations in supply lines
 - valve operating below minimum capacity requirements

MODEL IDENTIFICATION

To be sure you are installing appropriate parts into your valve, determine the model number. The easiest way to do that is to look at the date code (found on the bonnet of the valve). The date code (not to be confused with the product or part number) is a four-digit code. Its purpose is to record the model/version number of the product itself and the date of manufacture. (See circle "B" in the figure below for location of date code.)

In the example below, the Date Code is labeled by circle "B". The first digit, 8, indicates the model number. The bonnet also indicates the maximum setting. In the figure below, circle "A" shows the location of the temperature range: "115" (a standard valve).

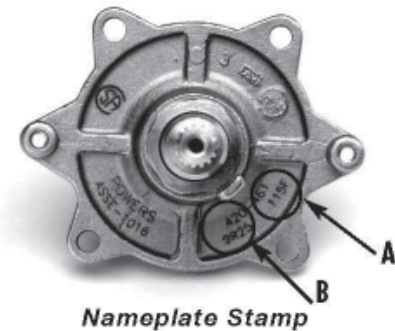

Nameplate Stamp

Checkstops are required with this valve to prevent crossflow.

PARTS LIST

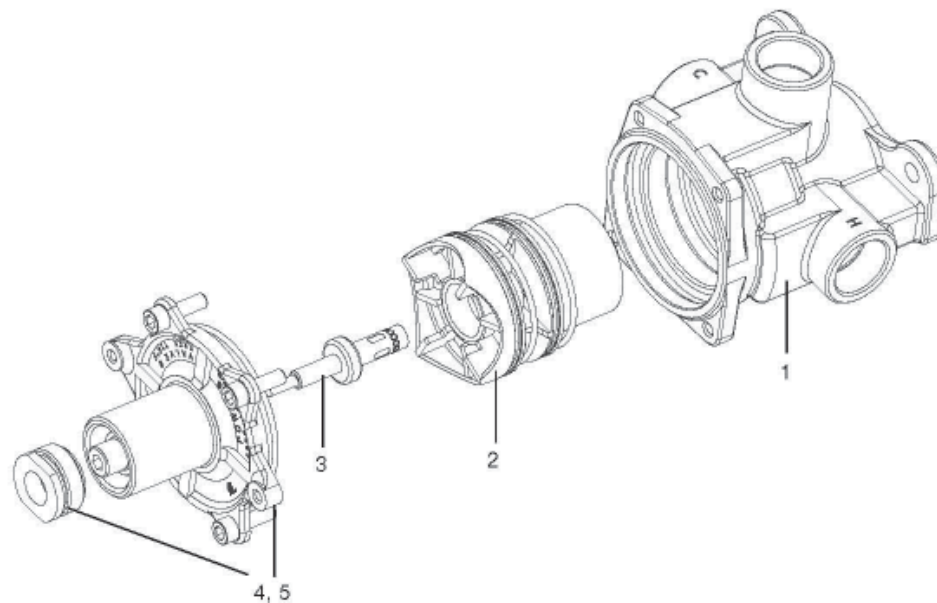

PART NUMBERS

INDEX	PART #	DESCRIPTION
1	N/A	Body
2	420 452	Cartridge Kits
3	420 024	Wax Element
4	420 060	Bonnet Kit, RB
5	420060A	Bonnet Kit, CP

SERVICING

- Before disassembling valve piping, turn off valve and the supply water upstream.
1. Remove four bonnet screws and pull out bonnet assembly. The motor should come out with the bonnet. If not, it can easily be pulled out.
 2. Remove the cartridge
 3. Reassemble the valve in reverse order.
- IMPORTANT: After completing any maintenance/repairs, check maximum discharge temperature. Adjust if necessary.
4. **Maximum temperature setting:** The high temperature limit stop is threaded on to the bonnet and is turned counter clockwise for an increased setting and clockwise for a decreased setting. Powers recommends a maximum setting of 110°F (43°C). To adjust the temperature, rotate stem to the maximum desired outlet temperature, screw temperature limit stop until it touches stem's shoulder. Close valve and open it to verify setting.

DIMENSIONAL DATA

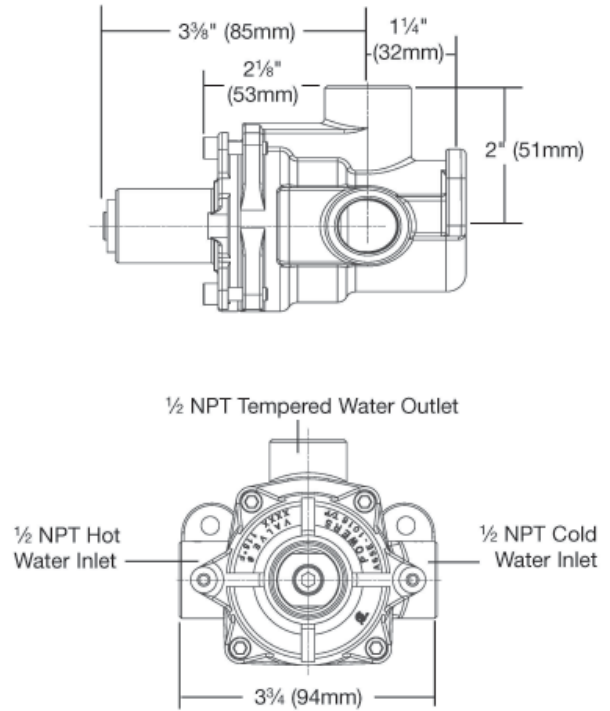

CHECKSTOPS

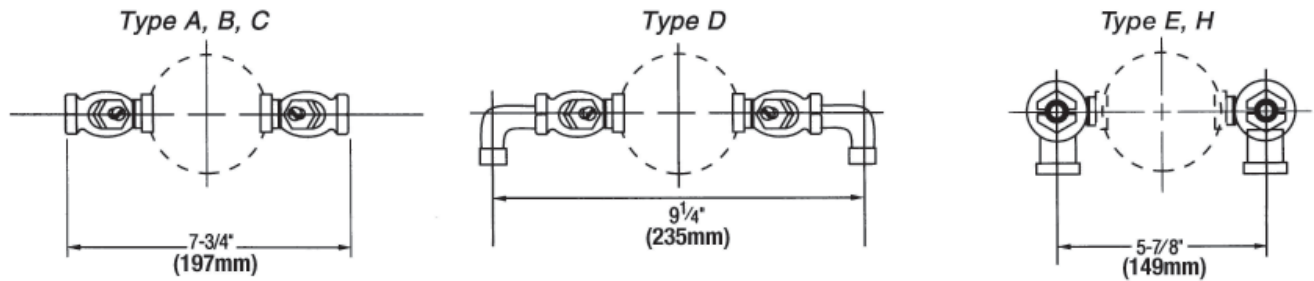

WARRANTY INFORMATION

Powers warrants that the equipment manufactured by it is free from defects in material and workmanship and, without charge, equipment found to be defective in material and workmanship will be repaired, or at Seller's option, replaced F.O.B. original point of shipment, if written notice of failure is received by Seller within one (2) years after date of shipment, provided said equipment has been properly installed, operated in accordance with Seller's instructions, and provided such defects are not due to abuse or chemical decomposition by chemical or galvanic action. This express warranty is in lieu of and excludes all other warranties, guarantees, or representations, express or implied. There are no implied warranties of merchantability or of fitness for a particular purpose. The Seller assumes no responsibility for repairs made on Seller's equipment unless done by Seller's authorized personnel, or by written authority from the Seller. The Seller makes no guarantee with respect to material not manufactured by it.

POWERS™
a division of Watts Water Technologies, Inc.

© 2007 Powers
USA: Phone: 1.800.669.5430 • Fax 1.847.229.0526 • www.powerscontrols.com
Canada: Phone: 1.888.208.8927 • Fax 1.888.882.1979 • www.powerscontrols.ca

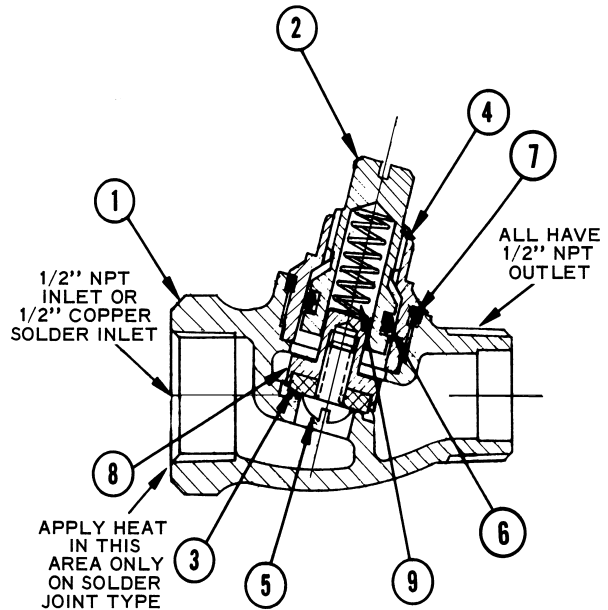
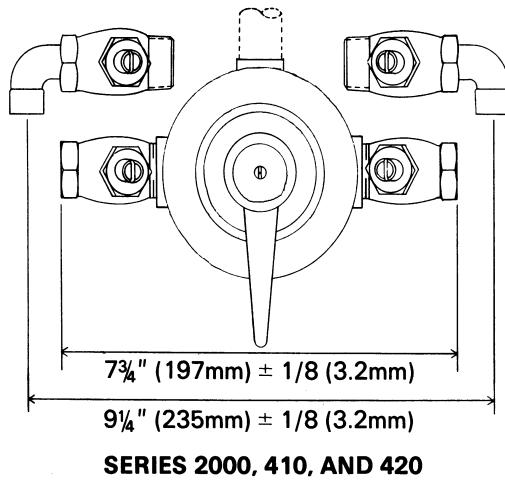

INSTALLATION INSTRUCTIONS

1. Connect the stop valves to the mixing valve with a 1-1/16" (27mm) wrench. Be sure the adjustment screw (2) is accessible.
2. Before inspecting or replacing the disc (3), or seal rings (6), and (7), the water supplies must be shut off at some other point. Remove the bonnet (4) with a 15/16" (23.8 mm) hex wrench.
3. The bonnet seal ring (7) and the disc (3) can be inspected or replaced. The disc retaining screw (5) must be removed before replacing the disc (3).
4. To inspect or replace the adjustment screw ring (6), unscrew the adjustment screw (2) from the bottom of the bonnet (4).

Part numbers shown below are for a pair of checkstops:

1/2" NPT screwed inlet straight:

Rough BronzeP/N 141-176
Polished Chrome Plate141-177

1/2" Copper solder inlet straight:

Rough BronzeP/N 141-187

1/2" Copper solder inlet angle:

Rough BronzeP/N 141-326

REPAIR KITS

ITEM	DESCRIPTION	PRODUCT NUMBERS			
		141-176	141-177	141-187	141-326
1	Body	N/A	N/A	N/A	N/A
2, 4	Stem and Bonnet Kit	230-337	230-337A	230-337	230-337
3, 5, 6, 7, 8, 9	Internal Parts Kit	141-845	141-845	141-845	141-845

Above kit contains parts for one pair.

CALIFORNIA PROPOSITION 65 WARNING

WARNING: This product contains chemicals known to the State of California to cause cancer and birth defects or other reproductive harm. (California law requires this warning to be given to customers in the State of California.)
For more information: www.wattsind.com/prop65



*Cost effective, compact
elapsed time indicator ...
large display with
backlighting*

All in the family - Other matching A103 series products in this catalog:

A103 Totalizing Counters:	Page 1.02
A103 Preset Counters:	Page 2.07
A103 Tachometers/Rate Indicators:	Page 4.04 - 4.06
A103 Preset Timers:	Page 5.05



The A103 Elapsed Time Indicators provide a range of capabilities unequalled in products of similar size and cost. A single model can be programmed to display in seconds, minutes, hours, or hours: minutes: seconds. The A103 series also includes matching indicators for count totalization and rate metering, as well as models with a preset output for control by count or time. All are in a uniform 36 x 72 millimeters bezel size package, enhancing your control panel with a family of devices that look and program alike.

A supertwist LCD display with thick 12mm (.47") high digits allows for easy viewing at a glance and feature display-backlight capability by simply connecting an external 12VDC supply.

Powered by an internal 3 volt battery, the A103's unique design has two battery slots; this allows battery changeover without loss of memory.

Timing start/stop can be initiated by solid-state signals or mechanical switches.

- Matching totalizing and preset counters, preset timers, tachometer/rate indicators are available – look great together on a panel
- High visibility 7-digit LCD display with backlighting capability standard
- Long life 3 Volt lithium battery eliminates the need for external power
- Accepts input signals from a variety of sources: Dry Contact, PNP or NPN Sensors
- Single multirange model covers popular time resolutions
- Resettable remotely or from the front panel
- Programmable security of front panel reset button
- Option modules provide additional functionality and added convenience – fast, easy installation
- NEMA 4X/IP65 rated front panel for use in washdown environments

The A103 timers are further enhanced by a series of quick-attach option modules. These can provide a power supply for sensors and display backlighting, and accept high or low voltage AC or DC input signals.

SPECIFICATIONS

Start/Stop Input: NPN, Contact Closure; Accumulates time when connected to common; Low State: < 1.0 VDC, High State: > 2.0 VDC (28VDC max)

Security Input: Allows access to panel reset and programming features

Remote Reset Input: NPN or Contact Closure to common; level sensitive

Power Source: Single or dual 3V Lithium battery; typical 5 years life w/single battery, 10 years w/dual batteries

Ranges & Resolution: Seconds, minutes to 1/10, hours to 1/10, hours: minutes: seconds

Display: 12mm high, Supertwist LCD; 7 digits; "Low Bat" indicator

Backlighting: Green Illumination over whole viewable area. Requires 10 to 28 VDC power source

Dimensions & Mounting: See dimensions figure. Panel Mount with supplied mounting bracket and gasket

Connections: Screw terminals

Weight: Approximately 64 grams (2.25 ounces)

OPTION MODULE SPECIFICATIONS

Option modules accessories provide a convenient integrated solution to applications that require AC or high voltage DC signals, and/or a voltage source for use with the A103's display backlight feature or external. Specifications for each option module feature follow, while specific combinations of features are listed in the "Models" table, below.

High Voltage Input: Allows A103 to accept 100 to 260 Volt AC/DC as timing input

Low Voltage Input: Allows A103 to accept 5 to 30 VAC or VDC as timing input

AC Power Supply: Provides 10 - 20 VDC @ 50 mA for display backlighting and/or sensor. Requires connection to 115 or 230 VAC, 50/60 Hz

Model No.	Description		
A103-006	A103 Elapsed Time Indicator		
The following option modules attach to the rear of A103 timers:			
Model No.	AC Power Supply	Low Voltage Input	High Voltage Input
A103-A12	X		
A103-A17		X	
A103-A19	X	X	
A103-A10			X
A103-A14	X		X
Replacement Battery: 605472-0001			
Panel Hole Punch: A103-A40			

Dimensions:

