



User Manual of

**W20-GSM indoor single
band selective repeaters**

Amplitec Corporation

CATALOGUE

CHAPTER 1. SAFETY WARNNING	2
CHAPTER 2. SUMMARY	3
CHAPTER 3. SPECS AND FEATURES	4
3.1 FEATURES	4
3.2 SYSTEM DIAGRAM	4
3.3 ELECTRICAL SPECIFICATION	4
3.4 MECHANICAL SPECIFICATION.....	4
3.5 APPEARANCE DIAGRAM	6
3.6 PORTS.....	6
CHAPTER 4. INSTALLATION	7
4.1 INSTALLATION REQUIREMENTS	7
4.2 INSTALLATION	7
4.3 CONNECTION	9
4.4 SYSTEM INSPECTION	10
CHAPTER 5. REPEATER SETTING	10
5.1 POWER SUPPLY CONNECTION	10
5.2 PERFORMANCE SETTING	11
CHAPTER 6. ENGINEERING MAINTENANCE	13
6.1 OPERATION AND MAINTENANCE	13
6.2 EMERGENCY DEALING	13
6.3 MAINTAINING DIRECTIONS.....	14

Chapter 1. Safety Warning

Users must follow the below principles:



1. Repeater should follow system requirement of communication equipment, assure good groundings and lightning protection.



2. The power supply voltage of repeater should meet the standards of security requirement; any repeater-operator can operate only after cutting power in advance. Only the professional can operate electrified.



3. Do not dismantle machine, maintain or displace accessories by yourself, because in this way, the equipment may be damaged or even get an electric shock.



4. Do not open the repeater, touch the module of repeater, even not to open the cover of module to touch the electronic component, the components will be damaged due to electrostatic



5. Please keep away from heating-equipment, because the repeater will dissipate heat when working. And do not cover repeater with anything that influences heat-dissipation.

Chapter 2. Summary

In mobile communication, it is inevitable that macro-cell coverage cannot cover weak or dead zones; to use repeater is a good choice in these areas. Single band selective repeaters mainly applied in covering small blind and weak zones.

Indoor single band selective repeater W20-GSM is a good choice for VIP rooms, offices, houses, restaurants, apartments, packing, etc.



Picture 2.1 Application

Indoor single band selective repeater W20-GSM enhances consumer satisfaction greatly with its integrated design, compact size, easy engineering and rapid installation and debugging,

Indoor single band selective repeater W20-GSM is made with the characteristics of industrial aesthetic design, and thus can be installed in high-class places as a decoration.

SAW filter technology enables it to amplify only the targeted operator's signals and reject all the others effectively, it is, therefore, an optimal solution for coverage extension.

Chapter 3. Specs and features

3.1 Features

- Adjustable range of 31dB at 1dB per step.
- Advanced digital controlled frequency selection to ensure high out of band rejection.
- Highly stable power design, to work normally even in very tough power environments.
- ALC technology to maintain stable signal in coverage areas

3.2 System diagram

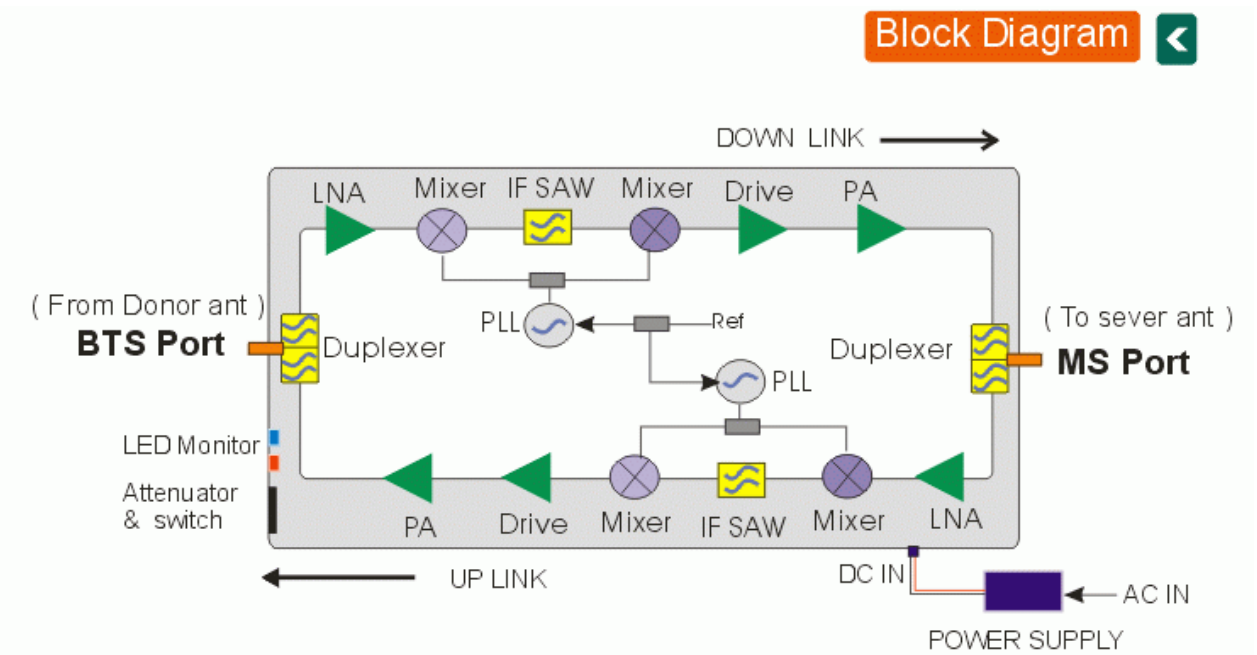

3.3 Specification

W20-GSM		
Electrical Specification	Uplink	Downlink
Frequency Range	890.1 ~ 901.1 MHz	935.1 ~ 946.1 MHz

Max.Gain		$\cong 65\text{dB}$	$\cong 70\text{dB}$
Band width		11MHz	
Gain Adjust Range		31dB in step of 1dB	
Automatic Level Control		$\cong 20\text{dB}$	
Ripple in Band (P-P)		$\leq 3\text{dB}$	
Output Power		$\cong 15\text{dBm}$	$\cong 20\text{dBm}$
Max. Input Power Without Damage		$\cong 0\text{dBm}$	
Out of Band Gain		$\pm 400\text{ KHz} \cong +50\text{dB}$	
		$\pm 600\text{ KHz} \cong +40\text{dB}$	
		$\pm 1\text{ MHz} \cong +35\text{dB}$	
		$\pm 5\text{ MHz} \cong +25\text{dB}$	
Intermodulation Products	9KHz~1GHz	$\cong -36\text{dBm}$	
	1GHz~12.75GHz	$\leq -30\text{dBm}$	
Spurious Emission	9KHz~1GHz	$\cong -36\text{dBm}$	
	1GHz~12.75GHz	$\cong -30\text{dBm}$	
Noise Figure		$\cong 6\text{dB}$	
VSWR		$\cong 2\text{dB}$	
Time Delay		$\cong 5\mu\text{s}$	
MTBF		$> 50000\text{hours}$	
Power Supply		AC160~264V, 50/ 60Hz	
Impedance		50 ohm	
Mechanical Specification			
I/O Port		N-Female	
Dimensions (D x W xH)		268*225*58mm	
Weight		$\cong 3.5\text{Kg}$	
Installation Type		Wall Installation	
Environment Conditions		IP40	
Environmental Specifications			
Humidity		$< 90\%$	
Operating Temperature		$-10^{\circ}\text{C} \sim 55^{\circ}\text{C}$	
LED Indication			
Power LED		DC ON/OFF	
Alarm LED		ALC 1~5dB,orange	
		ALC 20~25dB,red	

3.4 Appearance Diagram

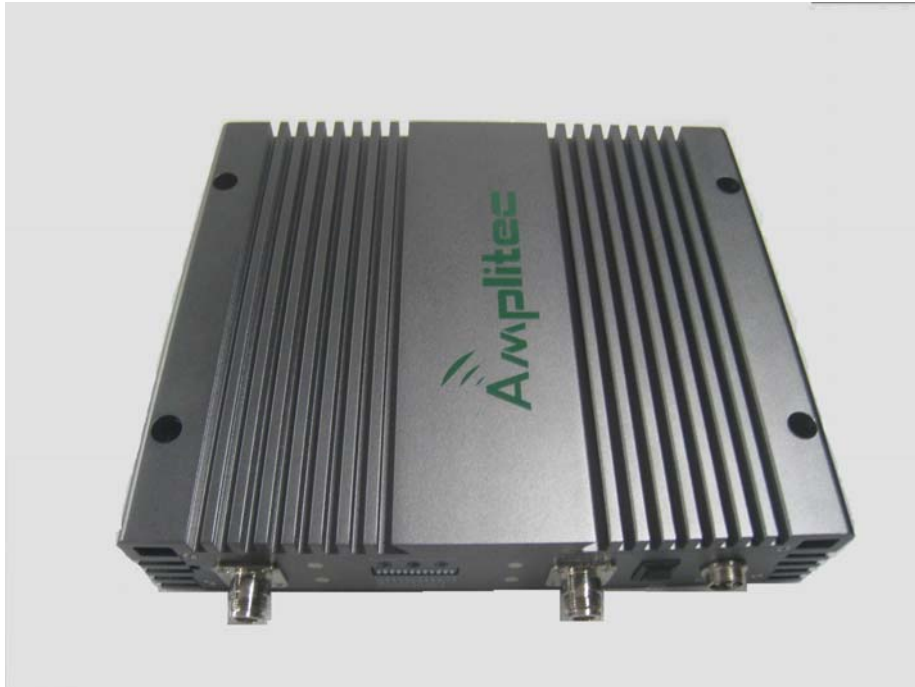

3.5 Ports



A B

C D E F

G

H

I

- A、Grounding
- B、Connection of Donor antenna
- C、Downlink Alarm Indicator
- D、Power Indicator
- E、Attenuator of GSM/WCDMA(UL/DL)
- F、Uplink Alarm Indicator
- G、Connection of Sever antenna
- H、Power Switch
- I、Connection of DC Power Supply

Chapter 4. Installation

4.1 Installation requirements

Indoor single band selective repeaters W20-GSM are mainly applied as indoor coverage system, the changes of air moisture and temperature may influence its reliability. So such factors as the temperature, air moisture, dustproof, current source and space requirement, etc shall be fully considered during installation.

■ Position selection

- Install in the place that is not easy to be reached by irrelevant people.
- Install at the place that is convenient for power supply and cabling.
- Avoid heat source and moist environment
- Install at drought space, hang on wall vertically in order to assure good heat distribution.

■ Power supply requirement

AC power supply of 160~264V, 50/ 60Hz

■ Installation tools and accessories

Serie s	item	specification	Quantity	Remarks
1	Expanding plug	M7	4	Accessories
2	Tapping screw	M6*40	4	Accessories
3	Spinner			
4	Waterproof tape			
5	Ruler		1	measurement and installation of hole
6	Percussion drill		1	drilling on wall

4.2 Installation

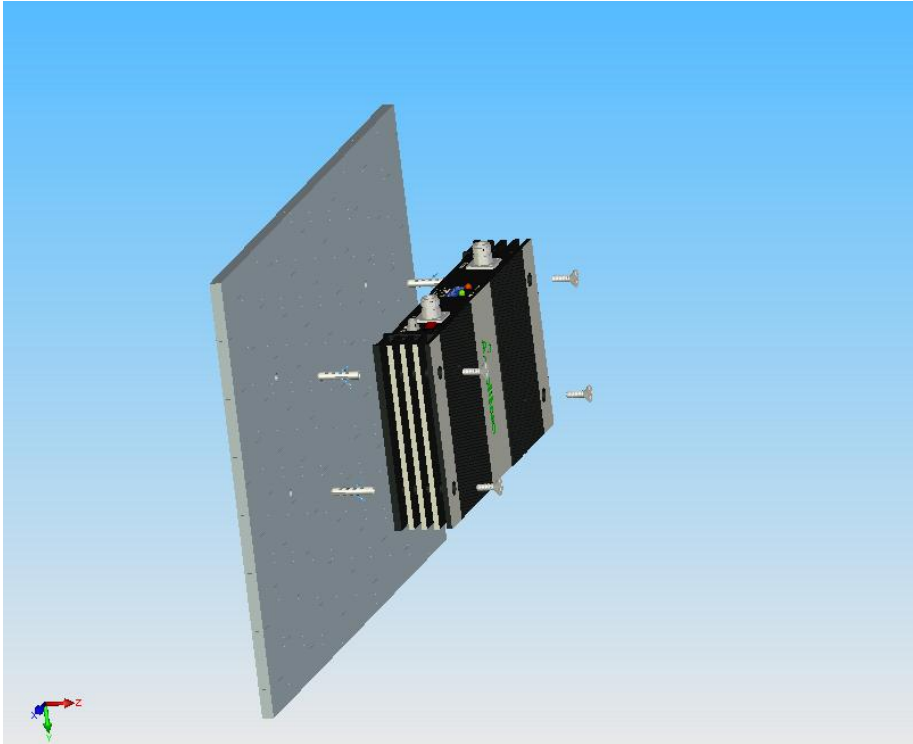

Picture 4.1 Installation diagram

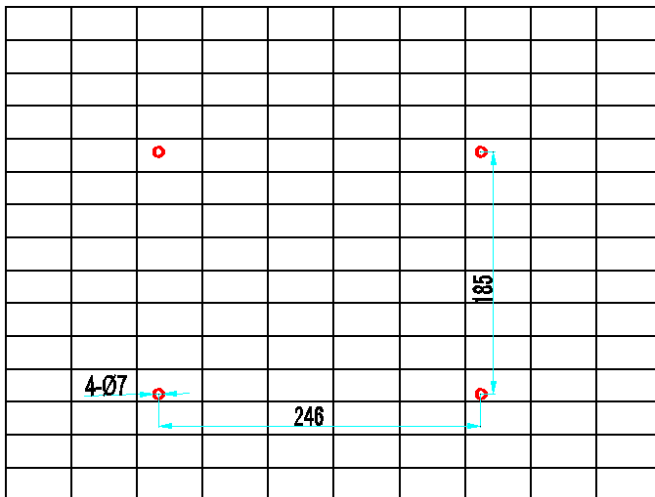

Picture 4.2 Hole positions

Installation Steps:

- A) Use percussion drill to make four $\Phi 6$ holes on the wall according to above hole diagram.
- B) Fill the holes with expanding plug
- C) Put the tapping screw through the holes and fit tightly with the expanding plug, and fasten the repeater onto the wall.
- D) Make sure that the installation is firm and correct

4.3 Connection**■ Connection of RF cable**

Input Port : donor antenna cable is connected with BS Port;

Output Port : service antenna cable is connected with Output Port;

■ Grounding

Please connect one end of a copper wire with the intersection size of 16mm² with the grounding screw, and the other end with the grounding system of the building. It is requested that the grounding impedance shall be less than 10Ohm.

■ Power supply connection

Installation of air switch is recommended for the convenience of power supply switch off.

Please use three-pin plug to assure good grounding

Please use the grounding screw, nut, washer to connect the grounding wire and repeater shell

Lightening Arrestor can be installed if necessary

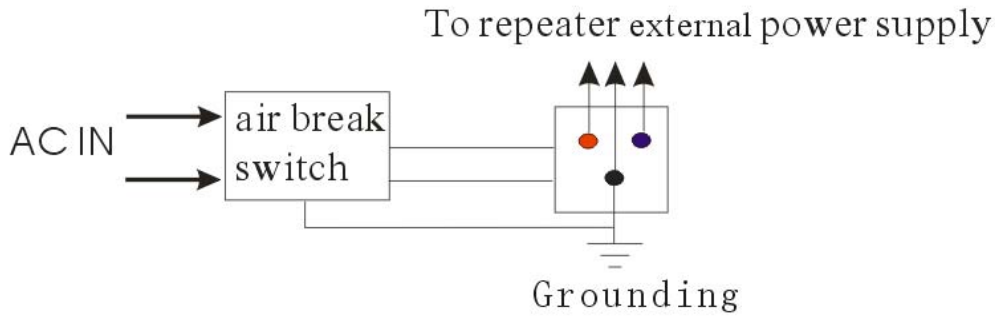

Picture 4.3 Power supply connection

4.4 System inspection

The followings should be checked after installation:

- Grounding impedance <math>< 10\Omega</math>;
- Antenna socket, cable are well grounded;
- Power supply lightning protection
- Building lightning protection
- Antenna lightning Protection.

Chapter 5. Repeater setting

Please check whether the connection of RF cable is correct (donor antenna connected to Input Port, service antenna connected to Output Port), and whether every port is stable. After affirmation, please go along the followings:

5.1 Power supply connection

After power supply connection, check ALARM and POWER indicators first.

- Status and definition of POWER indicators:

Status	Definition
Green	Normal
Off	DC power problem

- Status and definition of ALARM indicators:

Status	Definition of ALARM
--------	---------------------

Green	Meaning: working in linearity
	<i>attention: Input signals may be not enough</i>
Red	Meaning: overloading or self oscillation, strong input signals
	<i>Attention: cut the connection of equipment and service antenna, then connect the Output Port to load, if the red light changes to green or orange, which means the isolation of donor antenna and service antenna is not enough, then please adjust the isolation. If the red light still turning on that means over accepting of donor antenna or strong interference, then please adjust the place of donor antenna..</i>
Orange	Meaning: it is working in linearity
	<i>Notice: Please adjust MGC to increase the attenuation value, till you find the "edge point", and let the repeater work at this point.</i>
Off	Repeater break down

5.2 Performance Setting

✧ Curve chart of equipment working condition

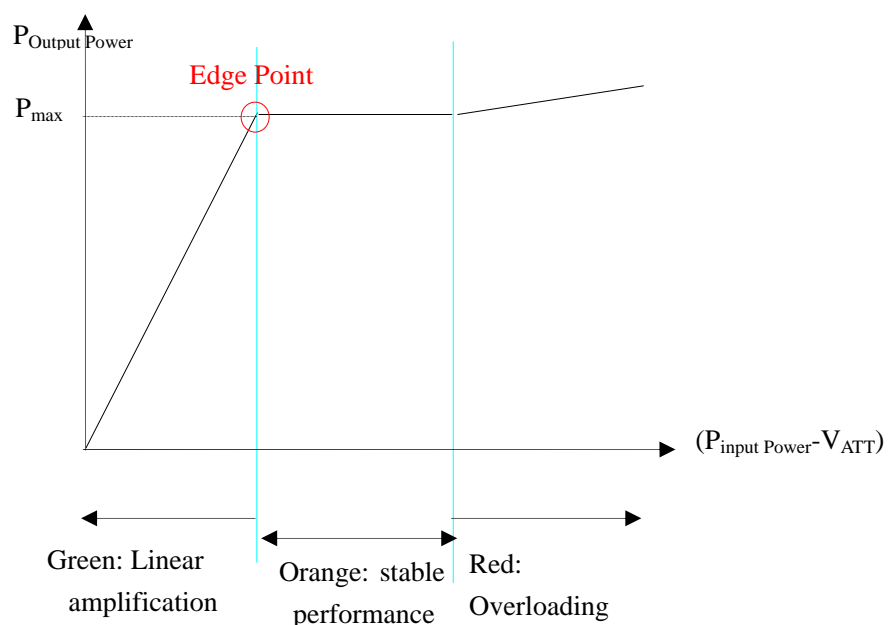

Picture 5.1 : Curve of output power, input signal and attenuation

value

$P_{\text{Output Power}}$: output power

$P_{\text{Input Power}}$: input power

V_{ATT} : attenuation value

$P_{\text{Input Power}} - V_{\text{ATT}}$: input power—attenuation value

P_{max} : output power rating

✧ **Downlink gain setting**

As for the downlink working performance, “orange” is a good working point. At this time, downlink output power and coverage effect are stable.

But from another point of view, we hope the equipment is as far as possible away from overloading status of “red” (thus the equipment would hold higher interference depression ability). So we try our best to set the equipment near “edge point” when engineering.

Setting of “edge point”: (Switch on the power supply after connection with donor antenna and coverage antenna, and observe ALARM indicator.)

- If it shines “orange”, use 1dB as stepping to increase attenuator until “green” turns on, then decrease 1~3dB attenuation value until “orange” turns on. The setting of downlink gain can reach the perfect status.
- If it shines “green” then,
- ◆ To check whether the attenuation value has been set, if it is, use 1dB as stepping to decrease attenuation until the “orange” turns on, then the downlink gain can reach the perfect status.
- ◆ But if attenuation is not set, it indicates that the input power is not enough.
 - Then please check coverage effect first, if the coverage effect is good, the engineering has reached expecting target
 - But if the coverage effect is not so good, the donor antenna should be adjusted until “orange” turns on or the effect reaches the target.

◇ Uplink gain setting

Uplink gain is set based on downlink gain..

Standards: uplink attenuation value=downlink attenuation value

Chapter 6. Engineering Maintenance

6.1 Operation and maintenance

- Equipment Disassembly

Close the outside air switch

Plug off the power supply

- Cleaning

Close the outside air switch

Plug off the power supply.

Do not use liquid materials to clean the equipment to avoid short circuit;

Please use dry dishclout

- Grounding

Using grounded power plug (three-pin plug)

- Power supply

Please make sure the voltage and frequency comply with the repeater requirement.

Component replacement

Please do not maintain or replace components by yourself, otherwise may get an electric shock. Only the authorized professional can maintain and replace the components.

- Waterproof and moist proof

Please do not turn on or off the booster in moist environment when its door is opened.

6.2 Emergency dealing

Switch off is recommended during following situations:

- The power supply is not normal

- Liquid flows into the equipment;
- Working conditions is not normal, (overheating, abnormal smelling, abnormal sundries)
- Closet damage
- Performance decrease
- Near to fire
- Flooding

6.3 Maintaining directions

Please check the booster step by step according to below processes, to find out the problem with the repeater.

