



Instructions and Parts List

3M-Matic™

200a

Type 39600

Adjustable

Case Sealer

with

AccuGlide™

Taping Heads

Serial No. _____
For reference, record machine serial number here.

3M Packaging Systems Division

3M Center, Building 220-8W-01
St. Paul, MN 55144-1000



Important Safety Information

Read "Important Safeguards", pages 3-5 and also operating "Warnings", page 14 BEFORE INSTALLING OR OPERATING THIS EQUIPMENT.

Spare Parts

It is recommended you immediately order the spare parts listed on page 31, Section I and page 17, Section II. These parts are expected to wear through normal use and should be kept on hand to minimize production delays.

"3M-Matic" and "AccuGlide" are Trademarks of 3M, St. Paul, MN 55144-1000

Litho in U.S.A.

© 3M 1999 44-0009-1894-4 (F69.0)

Replacement Parts and Service Information

To Our Customers:

This is the 3M-Matic™/AccuGlide™/Scotch™ brand equipment you ordered. It has been set up and tested in the factory with "Scotch" brand tapes. If technical assistance or replacement parts are needed, call or Fax the appropriate number listed below.

Included with each machine is an Instructions and Parts List manual.

Technical Assistance:

3M-Matic™ Helpline – 1-800/328 1390. Please provide the customer support coordinator with the machine number, machine type/model and serial number. If you have a technical question that does not require an immediate response, you may Fax it to 715/381 0248.

Replacement Parts and Additional Manuals

Order parts by part number, part description and quantity required. Also, when ordering parts and/or additional manuals, include machine name, number and type. A parts order form is provided at the back of this manual.

3M/Tape Dispenser Parts

241 Venture Drive

Amery, WI 54001-1325

1-800/344 9883

FAX# 715/268 8153

Minimum billing on parts orders will be \$25.00. Replacement part prices available on request.

\$10.00 restocking charge per invoice on returned parts.

Note : Outside the U.S., contact the local 3M subsidiary for parts ordering information.



3M Packaging Systems Division

3M Center, Building 220-8W-01
St. Paul, MN 55144-1000

"3M-Matic", "AccuGlide" and "Scotch" are trademarks of
3M, St. Paul, Minnesota 55144-1000

Printed in U.S.A.

© 3M 1999 44-0009-1851-4(E79.0)

Replacement Parts And Service Information

To Our Customers:

This is the 3M-Matic™/AccuGlide™/Scotch™ brand equipment you ordered. It has been set up and tested in the factory with "Scotch" brand tapes. If any problems occur when operating this equipment, and you desire a service call, or phone consultation, call, write or Fax the appropriate number listed below.

Included with each machine is an Instructions and Parts List manual.

**SERVICE, REPLACEMENT PARTS AND ADDITIONAL MANUALS
AVAILABLE DIRECT FROM:**

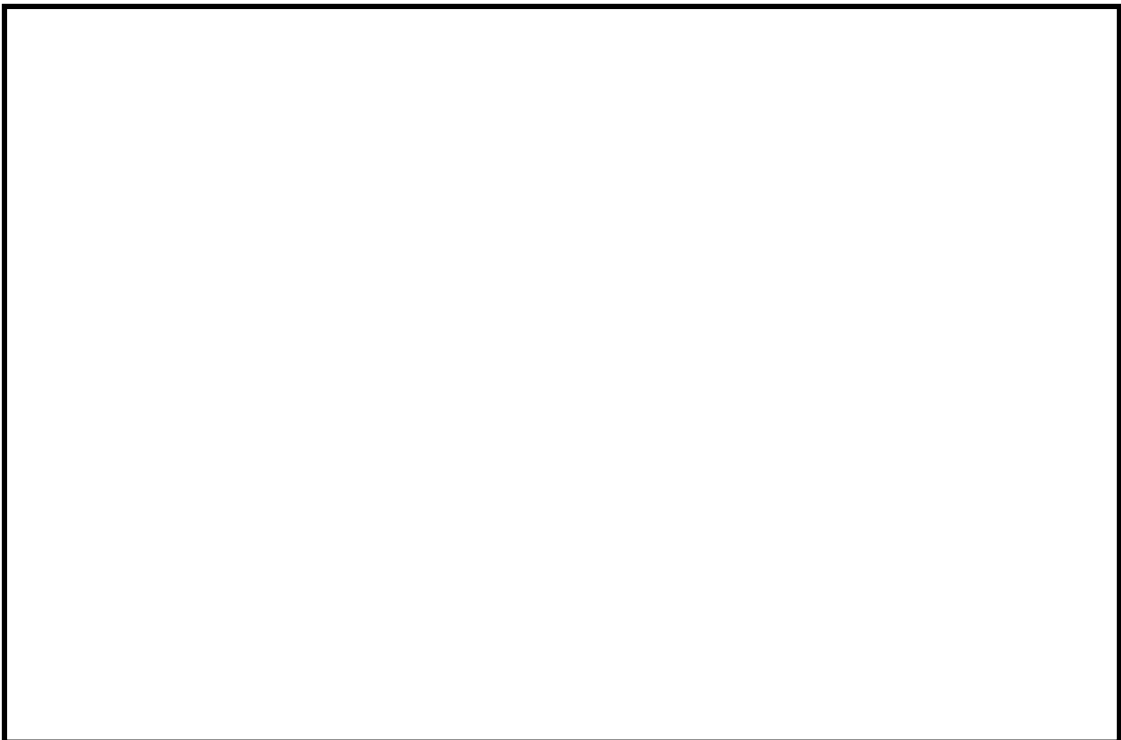

Order parts by part number, part description and quantity required. Also, when ordering parts and/or additional manuals, include machine name, number and type.

3M

3M Packaging Systems Division

3M Center, Building 220-8W-01
St. Paul, MN 55144-1000
1-800/328 1390

"3M-Matic", "AccuGlide" and "Scotch" are trademarks of
3M, St. Paul, Minnesota 55144-1000

Printed in U.S.A.

© 3M 1999 44-0009-1852-2(D79.0)

Instruction Manual

200a, Adjustable Case Sealer, Type 39600

This instruction manual is divided into two sections as follows:

- Section I** Includes all information related to installation, operation and parts for the case sealer.
Section II Includes specific information regarding the AccuGlide™ II STD 2 Inch Taping Heads.

Table of Contents

Page

Section I – 200a Adjustable Case Sealer

Description	1
Equipment Warranty and Limited Remedy	2
200a Contents	2
Important Safeguards	3 - 5
Specifications	6 - 8
Installation and Set-Up	9 - 11
Receiving and Handling	9
Machine Set-Up	9 - 11
Packaging and Separate Parts	9 - 10
Machine Bed Height	11
Outboard Tape Roll Mounting	11
Tape Leg Length	11
Box Size Capacity of Case Sealer	12
Electrical Connection and Controls	12
Initial Start-Up of Case Sealer	12
Operation	13 - 16
Electrical On/Off Switch	14
Tape Loading/Threading	14
Box Size Set-Up	15 - 16
Box Sealing	16
Maintenance	17 - 18
Cleaning	17
Lubrication	17
Circuit Breaker	18
Knife Replacement, Taping Head	18
Box Drive Belt Replacement	18

(Table of Contents continued on next page)

Table of Contents (Continued)	Page
Adjustments	19 - 21
Drive Belt Tension	19 - 20
Taping Head Adjustments	21
Special Set-Up Procedure	23 - 25
Changing Tape Leg Length	23 - 24
Box and Machine Bed Height Range	24 - 25
Troubleshooting	27
Electrical Diagram	29
Parts and Service Information	31
Options/Accessories	32
Replacement Parts Illustrations and Parts Lists (Yellow Section)	33 - 57

Section II – AccuGlide™ II STD 2 Inch Taping Heads

(See Section II for Table of Contents)

Description

The **3M-Matic™ 200a Adjustable Case Sealer with AccuGlide™ II Taping Heads** is designed to apply a “C” clip of **Scotch™** brand pressure-sensitive film box sealing tape to the top and bottom center seam of regular slotted containers. The 200a is manually adjustable to a wide range of box sizes (see "Specifications – Box Weight and Size Capacities", Page 7).

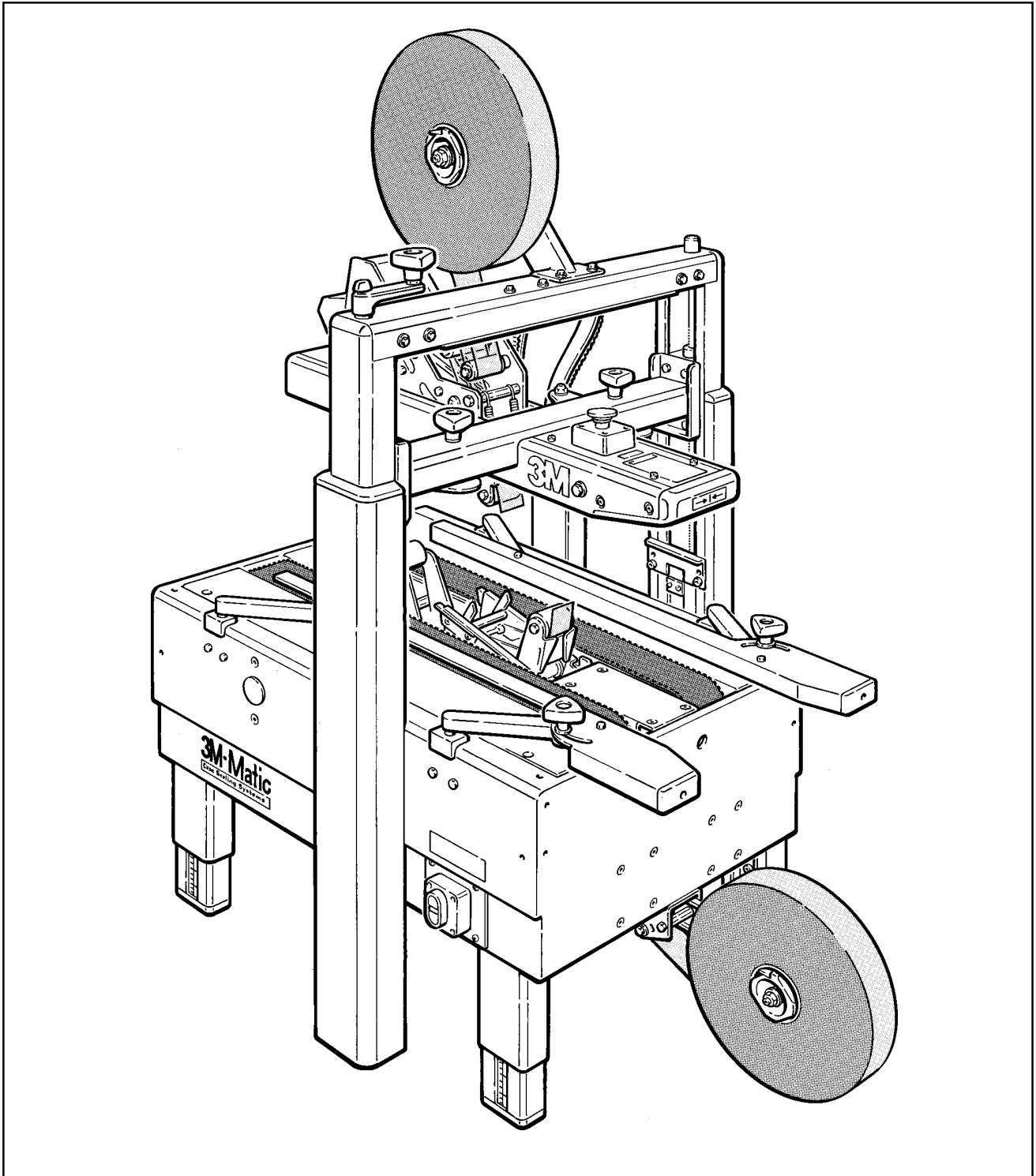

3M-Matic™ 200a Adjustable Case Sealer, Type 39600 (Note – Lower tape supply roll and bracket assembly are shown in the alternate location)

Equipment Warranty and Limited Remedy: THE FOLLOWING WARRANTY IS MADE IN LIEU OF ALL OTHER WARRANTIES, EXPRESS OR IMPLIED, INCLUDING, BUT NOT LIMITED TO, THE IMPLIED WARRANTY OF MERCHANTABILITY, THE IMPLIED WARRANTY OF FITNESS FOR A PARTICULAR PURPOSE AND ANY IMPLIED WARRANTY ARISING OUT OF A COURSE OF DEALING, A CUSTOM OR USAGE OF TRADE:

3M sells its **3M-Matic™ 200a Adjustable Case Sealer, Type 39600** with the following warranties:

1. The Taping Head knife, springs and rollers will be free from all defects for ninety (90) days after delivery.
2. All other Taping Head parts will be free from all defects for three (3) years after delivery.
3. The gearmotor will be free from all defects for one (1) year after delivery.
4. All other parts will be free from all defects for ninety (90) days after delivery.

If any part is proved to be defective within its warranty period, then the exclusive remedy and 3M's and seller's sole obligation shall be, at 3M's option, to repair or replace the part, provided the defective part is returned immediately to 3M's factory or an authorized service station designated by 3M. A part will be presumed to have become defective after its warranty period unless the part is received or 3M is notified of the problem no later than five (5) calendar days after the warranty period. If 3M is unable to repair or replace the part within a reasonable time, then 3M, at its option, will replace the equipment or refund the purchase price. 3M shall have no obligation to provide or pay for the labor required to install the repaired or replacement part. 3M shall have no obligation to repair or replace (1) those parts failing due to operator misuse, carelessness, or due to any accidental cause other than equipment failure, or (2) parts failing due to non-lubrication, inadequate cleaning, improper operating environment, improper utilities or operator error.

Limitation of Liability: 3M and seller shall not be liable for direct, indirect, special, incidental or consequential damages based upon breach of warranty, breach of contract, negligence, strict liability or any other legal theory.

The foregoing Equipment Warranty and Limited Remedy and Limitation of Liability may be changed only by a written agreement signed by authorized officers of 3M and seller.

Contents – 200a Adjustable Case Sealer

- (1) 200a Adjustable Case Sealer, Type 39600
- (1) Upper Assembly Height Adjustment Crank/Hardware
- (1) Upper Tape Drum/Bracket/Hardware
- (2) Column Stop Bracket/Hardware
- (1) Tool/Spare Parts Kit
- (1) Instruction and Parts Manual

Important Safeguards

 This safety alert symbol identifies important messages in this manual. **READ AND UNDERSTAND THEM BEFORE INSTALLING OR OPERATING THIS EQUIPMENT.**

Important – In the event the following safety labels are damaged or destroyed, **they must be replaced to ensure operator safety.** A label kit, part number 78-8113-6714-9 is available as a stock item or individual labels can be ordered. See Parts Illustration/List, Section I, pages 56 and 57.

The "**Warning – Hazardous Voltage**" label, shown in **Figure 1-2**, is attached to the electrical enclosure on the lower left side of the machine frame. The label warns service personnel to unplug the power supply before attempting any service work on the case sealer.



Figure 1-2 – Electrical Warning Label

The "**Warning – Sharp Knife**" label, shown in **Figure 1-1**, is attached to both sides of the upper ski assembly at the location of the cut-off knife on the upper taping head. The labels warn operators and service personnel of the very sharp knife used to cut the tape at the end of the tape application.

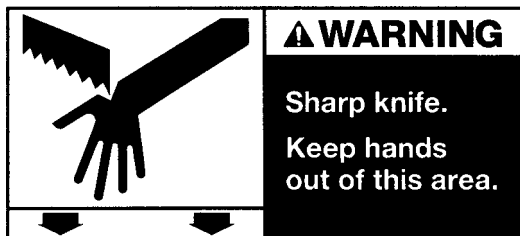

Figure 1-1 – Knife Warning Label

The "**Caution – Pinch Point**" label, shown in **Figure 1-3**, is attached to the center plate at the exit end of the machine bed. The label warns the operator to keep hands out of this area when the drive belts are running.

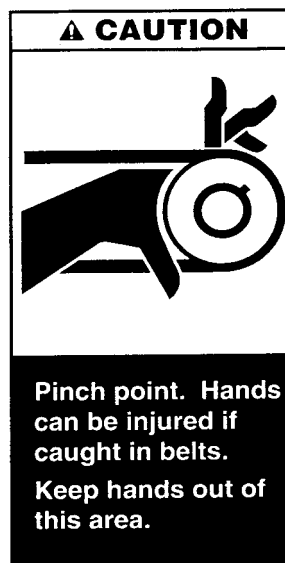

Figure 1-3 – Pinch Point Caution Label

Important Safeguards (Continued)

The "**Caution – Pinch Point**" label, shown in **Figure 1-4**, is attached to the top of the upper assembly crossbar on both sides of the machine. The label reminds operator to keep hands away from compression rollers when machine is running.

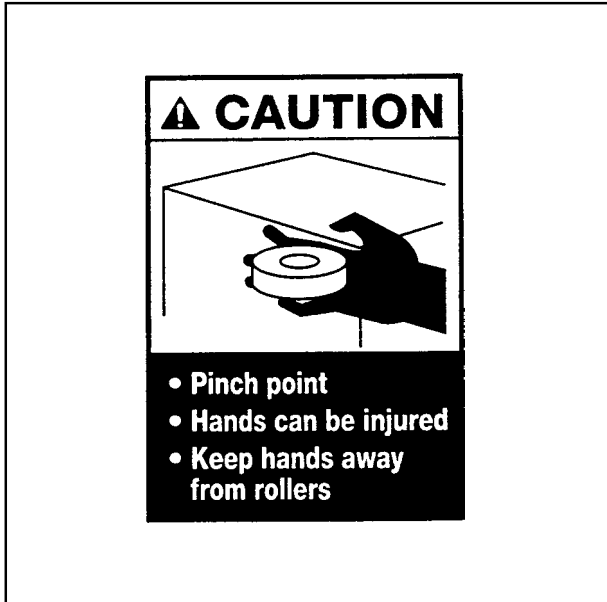

Figure 1-4 – Pinch Point Caution Label

The 200a is equipped with a "Red" emergency stop switch located on the top/front of the upper ski assembly. The "**Stop**" label, shown in **Figure 1-5**, is located near the switch and reminds operators and casual personnel of the function of this switch.

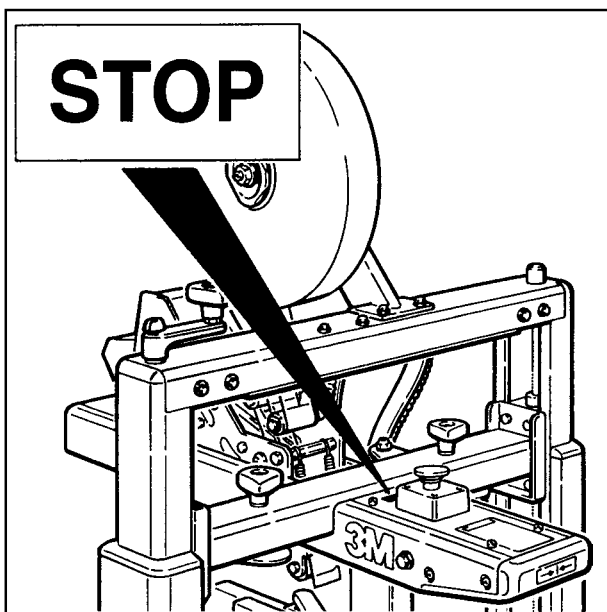

Figure 1-5 – Stop Label

The "**Safety Instructions**" label, shown in **Figure 1-6**, is attached to the top/front of the upper ski assembly. The label provides convenient safeguard instructions for the operator and service personnel.

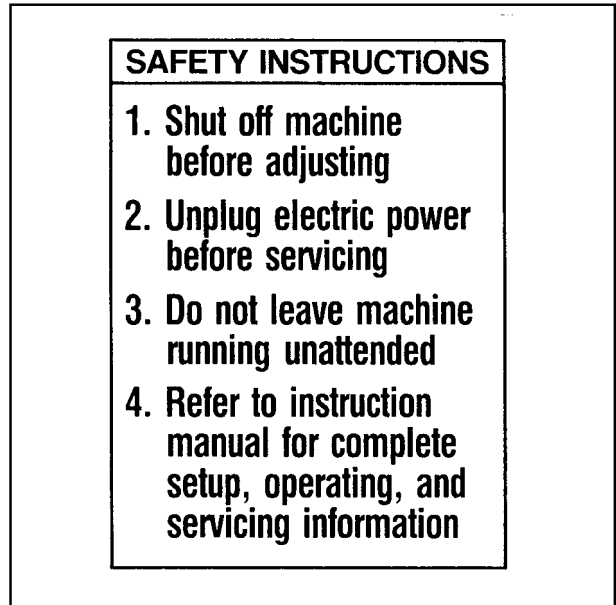

Figure 1-6 – Safety Instruction Label

The "**Center Box Here**" label, shown in **Figure 1-7**, is attached to the front of the upper frame to remind the operator of the proper box placement procedure.



Figure 1-7 – Center Box Label

Important Safeguards (Continued)

The "Up/Down/Lock" label, shown in **Figure 1-8**, is located on the top surface, on each side, of the upper column assembly. The label reminds the operator of the direction to turn the height adjustment crank to raise and lower the upper ski/taping head and the locking feature.

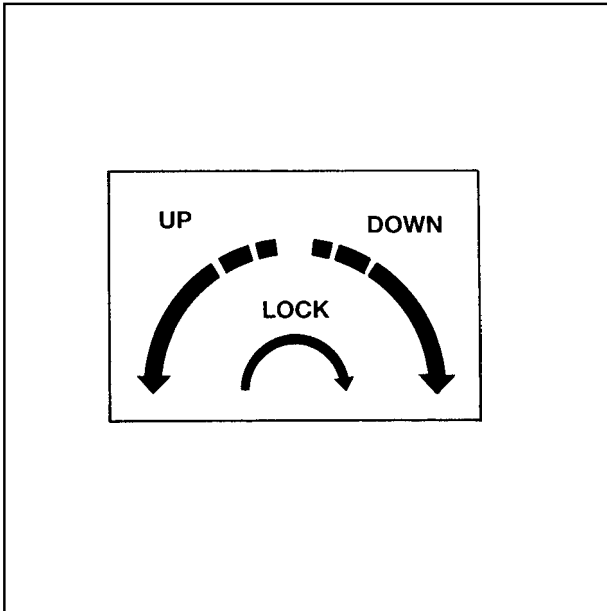

Figure 1-8 – Up/Down/Lock Label

The following two labels are located on the upper and lower taping heads. Replacement part numbers for these labels are listed in Section II.

The "Tape Threading Label", shown in **Figure 1-9**, is attached to the left side of both the upper and lower taping heads.

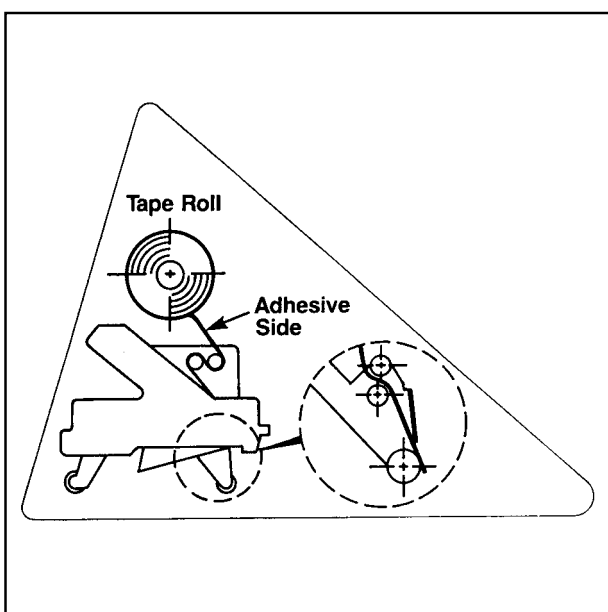

Figure 1-9 – Tape Threading Label

The "**Warning – Sharp Knife**" label warns operators and service personnel of the extremely sharp knife used to cut the tape at the end of the box sealing operation. The label, shown in **Figure 1-10**, is located on the orange knife guard between the applying roller assembly and the buffing roller assembly. **Never operate taping head with knife guard removed.**

Before working with the taping heads or loading/threading tape, refer to Figures 3-1 and 3-2 in Section II to identify the knife location. **Keep hands out of these areas except as necessary to service the taping heads or to load/thread tape.**

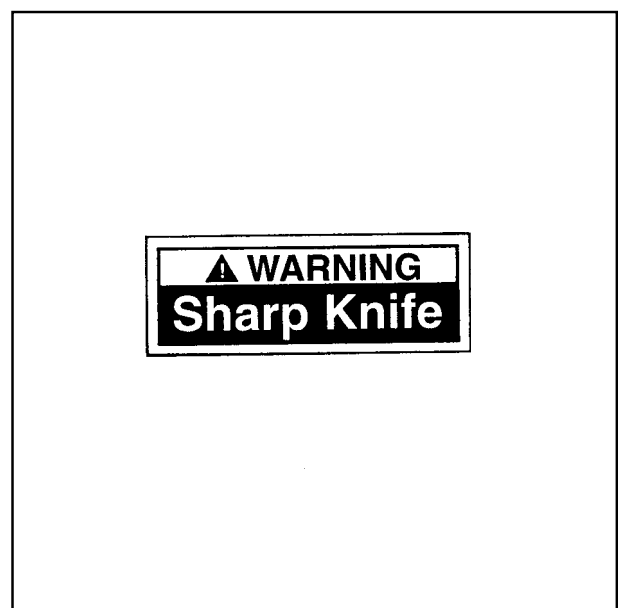

Figure 1-10 – Knife Warning Label

Specifications

1. Power Requirements:

Electrical - 115 VAC, 60 Hz, 1.9 A (220 watts)

The machine is equipped with a 1/6 HP gearmotor and comes with a standard neoprene covered power cord and a grounded plug. Contact your 3M Representative for power requirements not listed above.

2. Operating Rate:

Box drive belt speed is approximately 0.4 m/s [78 feet per minute].

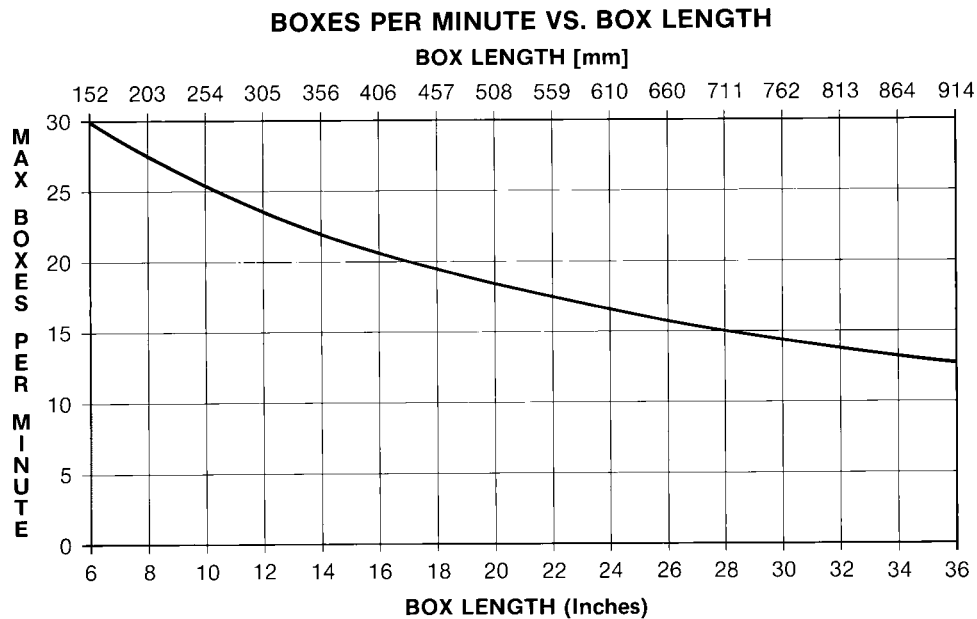

Actual production rate is dependent on operator's dexterity.
Boxes must be 18 inches [455mm] apart minimum.

3. Operating Conditions:

Use in dry, relatively clean environments at 5° to 40° C [40° to 105° F] with clean, dry boxes.

Note: Machine should not be washed down or subjected to conditions causing moisture condensation on components.

4. Tape:

Scotch™ brand pressure-sensitive film box sealing tapes.

5. Tape Width:

36 mm [1 1/2 inch] minimum to 48 mm [2 inch] maximum.

(Specifications continued on next page)

Specifications (Continued)

6. Tape Roll Diameter:

Up to 405 mm [16 inch] maximum on a 76.2 mm [3 inch] diameter core.
(Accommodates all system roll lengths of **Scotch™** brand film tapes.)

7. Tape Application Leg Length – Standard:

70 mm ± 6 mm [2.75 inch ±.25 inch]

Tape Application Leg Length – Optional:

50 mm ± 6 mm [2 inch ±.25 inch]

(See "Special Set-Up Procedure – Changing the Tape Leg Length", Page 23.)

8. Box Board:

Style – regular slotted containers – RSC

125 to 275 P.S.I. bursting test, single wall or double wall B or C flute.

9. Box Weight and Size Capacities:

A. Box Weight, filled – 2.3 kg [5 lbs.] **minimum**, 38.6 kg [85 lbs.] **maximum**.

B. Box Size:	Minimum	Maximum
Length –	150 mm [6.0 inch]	Unlimited
Width –	150 mm [6.0 inch]*	550 mm [21.5 inch]
Height –	120 mm [4.75 inch]** ***	620 mm [24.5 inch] ***

* Cartons narrower than 250 mm [10 inch] in width may require more frequent belt replacement because of limited contact area.

** 90 mm [3.5 inch] height with heads adjusted to apply 50 mm [2 inch] tape leg lengths. (See "Special Set-Up Procedure – Changing the Tape Leg Length", Page 23.)

*** 165 mm [6.5 inch] minimum to 725 mm [28.5 inch] maximum height with columns adjusted to upper position. (See "Special Set-Up Procedure – Box and Machine Bed Height Range", Page 24.)

**Special modifications may be available for carton sizes not listed above.
Contact your 3M Representative for information.**

Note: The case sealer can accommodate most boxes within the size range listed above. However, if the box length (in direction of seal) to box height ratio is .75 or less, then several boxes should be test run to assure proper machine performance.

DETERMINE THE BOX LIMITATIONS BY COMPLETING THIS FORMULA:

$$\frac{\text{BOX LENGTH IN DIRECTION OF SEAL}}{\text{BOX HEIGHT}} \quad \text{MUST BE GREATER THAN } .75$$

Any box ratio approaching this limitation should be test run to assure performance.

(Specifications continued on next page.)

Specifications (Continued)

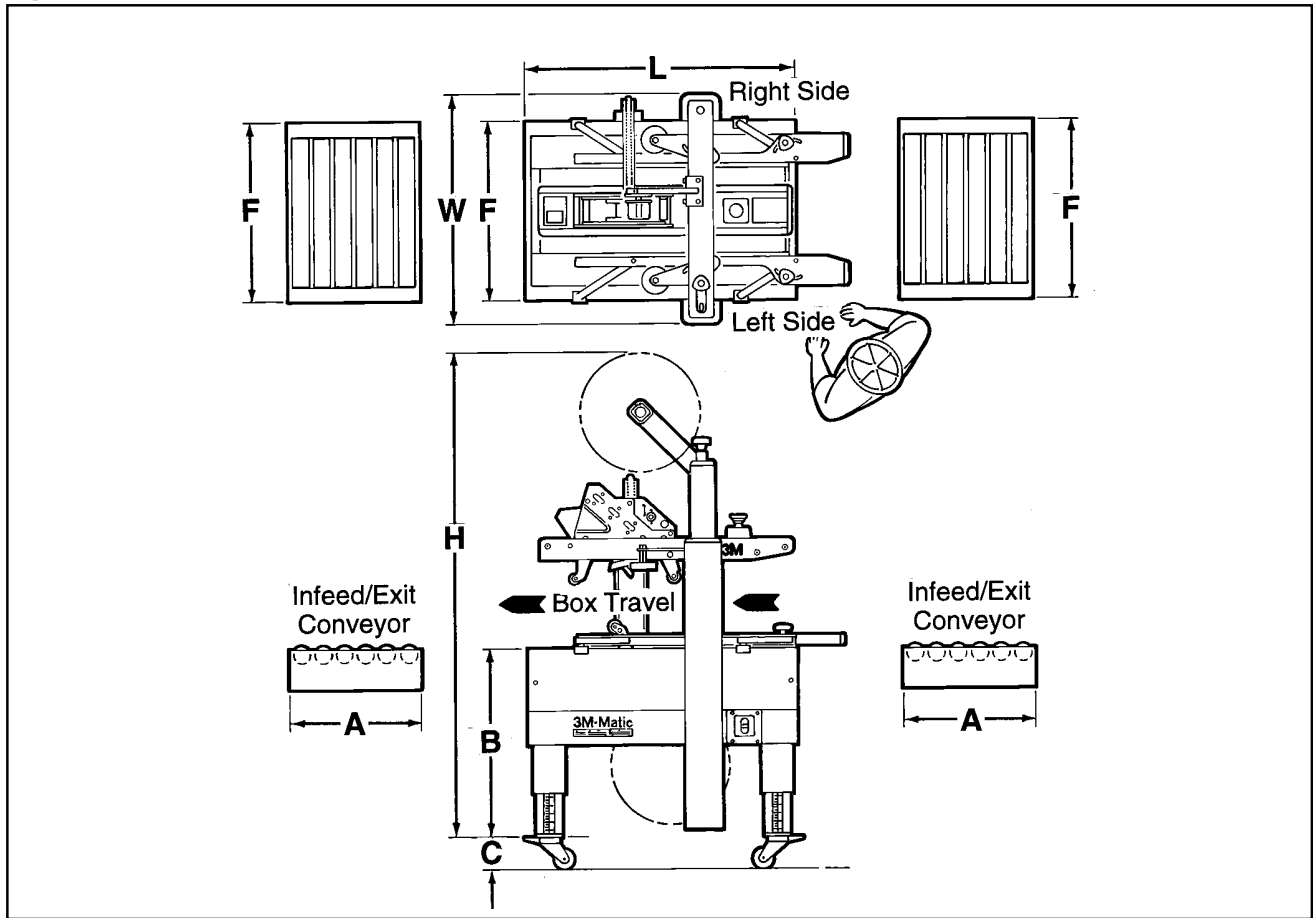

10. Machine Dimensions:

	W	L	H	A*	B	C**	F
Minimum							
mm	790	930	1350	460	610	100	620
[Inches]	[31]	[36 1/2]	[53]	[18]	[24***]	[4]	[24 1/2]
Maximum							
mm			2185		890		

* Infeed/Exit conveyors are optional
 ** Casters are optional
 *** When columns are adjusted to upper position, "B" minimum/maximum dimension decreases by 90 mm [3 1/2 inches] and "H" maximum dimension increases by 100 mm [4 inch]. (See "Special Set-Up Procedure – Box and Machine Bed Height Range", Page 24.)

Weight – 145.6 kg [320 lbs] crated (approximate)
 123.4 kg [280 lbs] uncrated (approximate)

11. Set-Up Recommendations:

- Machine must be level.
- Customer supplied infeed and exit conveyors (if used) should provide straight and level box entry and exit.
- Exit conveyors (powered or gravity) must convey sealed boxes away from machine.

Installation and Set-Up

Receiving And Handling

After the machine has been uncrated, examine the case sealer for damage that might have occurred during transit. **If damage is evident, file a damage claim immediately** with the transportation company and also notify your 3M Representative.

Machine Set-Up

Important – Read "Warnings", on page 14, before attempting to set-up the case sealer for operation.

The following instructions are presented in **the order recommended** for setting up and installing the case sealer, as well as **for learning the operating functions and adjustments**. Following them step by step will result in your thorough understanding of the machine and an installation in your production line that best utilizes the many features built into the case sealer. Refer to Figure 3-1 to identify the various components of the case sealer.

Note – A tool kit consisting of metric open end and hex socket wrenches is provided with the machine. These tools should be adequate to set-up the machine, however, other tools supplied by the customer will be required for machine maintenance.

5. Cut cable ties that secure upper assembly to machine bed on each side of machine. Remove and discard cable ties and protective foam sheeting.
6. Remove tape drum bracket bolts (4) from top crossbar and install tape drum bracket from parts box on top crossbar as shown in Figure 2-1A.
7. Install height adjustment crank handle on top of left column as shown in Figure 2-1B. Crank upper assembly up high enough to allow clear access to lower taping head. Remove and discard the two cushion shipping blocks.
8. Loosen both side guides, pivot to full open position and re-tighten locking knobs.
9. Wipe protective shipping oil off stainless steel covers on machine bed.
10. Cut and remove cable ties on both upper and lower taping heads. (Applying/buffing rollers are held retracted for shipment.)



WARNING – Follow this step carefully as spring pressure is applied to applying and buffing arms when cable tie is removed. Keep hands/fingers AWAY from tape cut-off knife under orange knife guard. Knife is extremely sharp and can cause severe injury.

PACKAGING AND SEPARATE PARTS

1. Lift fiberboard cover off pallet after removing staples at bottom.
2. Remove protective wrapping around machine.
3. Remove hardware that secures case sealer legs to pallet.
4. Cut and remove cable tie that secures black electrical conduit to the electrical mast on top of machine.

Hold taping head **BUFFING ROLLER** and cut and remove cable tie that holds applying/buffing arms retracted. See Figure 2-1C. Allow buffing/applying arms to extend slowly.

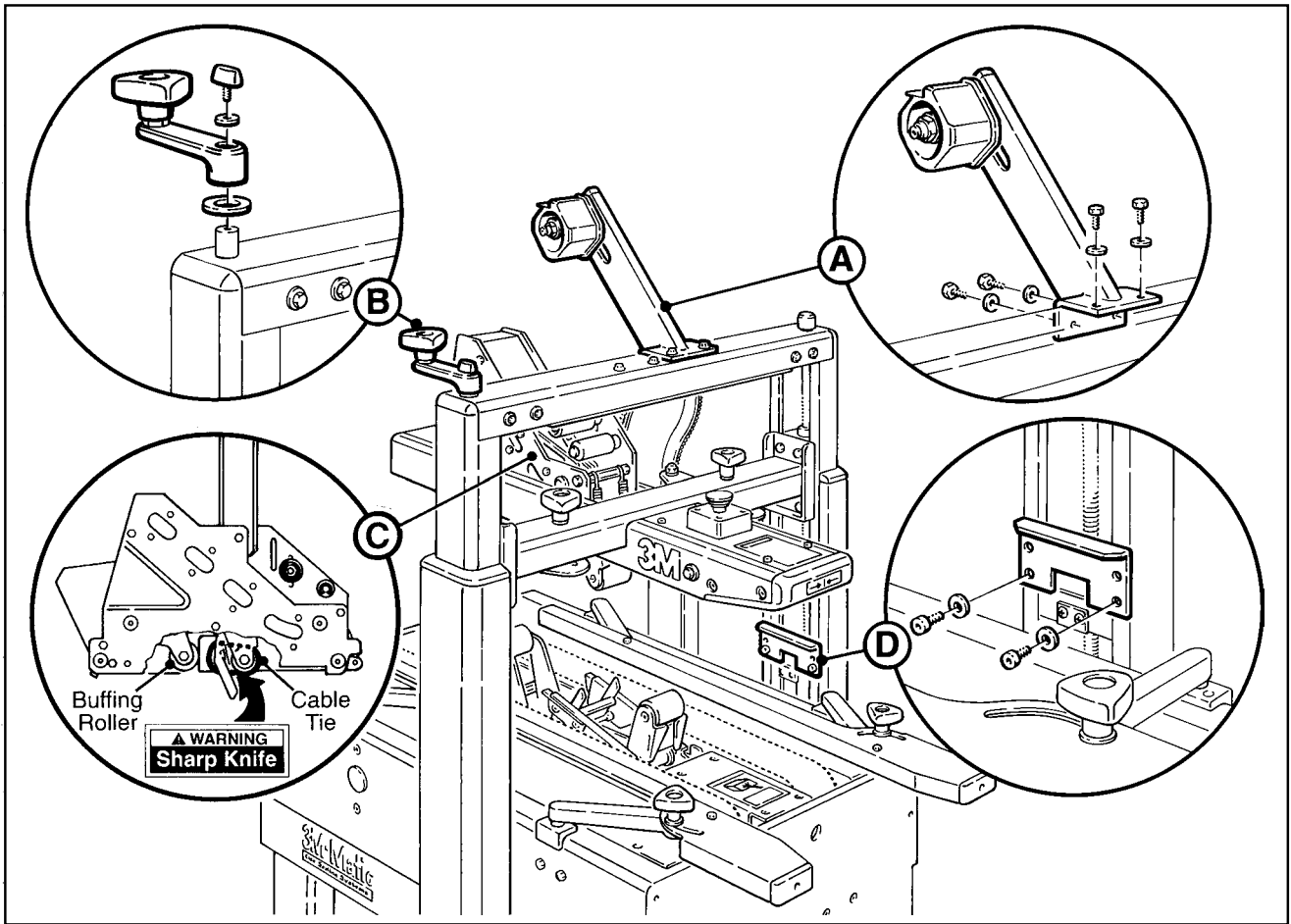

Figure 2-1 – 200a Frame Set-Up

11. Check for free action of both upper and lower taping heads.

WARNING – Keep hands/fingers away from tape cut-off knife under orange knife guard. Knife is extremely sharp and can cause severe injury.

Push buffing roller into head to check for free, smooth action of taping heads.

12. Loosen lock knobs and pivot side guides to center position. Install machine stops (from parts box) as shown in Figure 2-1D. Use the lowest hole position and bolt into the lowest threaded insert on the column. (The upper hole position in the stops are only used when the taping heads are adjusted to apply 50 mm [2 inch] tape legs.)

13. Ensure that the tape drum bracket assembly, located on the lower taping head, is mounted straight down, as shown in Figure 2-2A. The tape drum bracket assembly can be pivoted to provide tape roll clearance in certain cases.

14. Use appropriate material handling equipment to remove the machine from the pallet and move it into position.

Whenever the machine is lifted with a fork truck, insure that the forks span completely across the machine frame and do not contact any wiring or mechanism under the machine frame. In some cases the lower taping head may need to be removed to avoid damage.

CAUTION – Machine weighs approximately 123 kg [280 pounds] uncrated.

15. Continue with the remainder of the Installation and Set-Up procedure through page 12.

Installation and Set-Up (Continued)

MACHINE BED HEIGHT

Adjust machine bed height. The case sealer is equipped with four adjustable legs that are located at the corners of the machine frame. The legs can be adjusted to obtain different machine bed heights from 610 mm [24 in] minimum to 890 mm [35 in] maximum.

Note – Minimum machine bed height can be reduced to 520 mm [20.5 in] by moving outer columns up one set of mounting holes. However, this change also reduces minimum box height of 120 mm [4.75 in] to 165 mm [6.5 in]. (See "Special Set-Up Procedure – Box/Machine Bed Height Range", page 24.)

Refer to Figure 2-2C and set the machine bed height as follows:

1. Use appropriate material handling equipment and blocking techniques to raise the machine frame to allow adequate leg adjustment.

2. Loosen, but do not remove, two M8 x 16 socket head screws in one leg (use M6 hex wrench). Adjust the leg length for the desired machine bed height. Retighten the two screws to secure the leg. Adjust all four legs equally.

OUTBOARD TAPE ROLL MOUNTING (Lower Taping Head Alternate Position)

Remove the tape drum bracket assembly, spacer and fasteners from the lower taping head. Install and secure on the infeed end of the lower frame, as shown in Figure 2-2B.

TAPE LEG LENGTH

Taping heads are pre-set to apply 70 mm [2.75 in] long tape legs. To change tape leg length to 50 mm [2.0 in], see "Special Set-Up Procedure – Changing the Tape Leg Length", page 23.

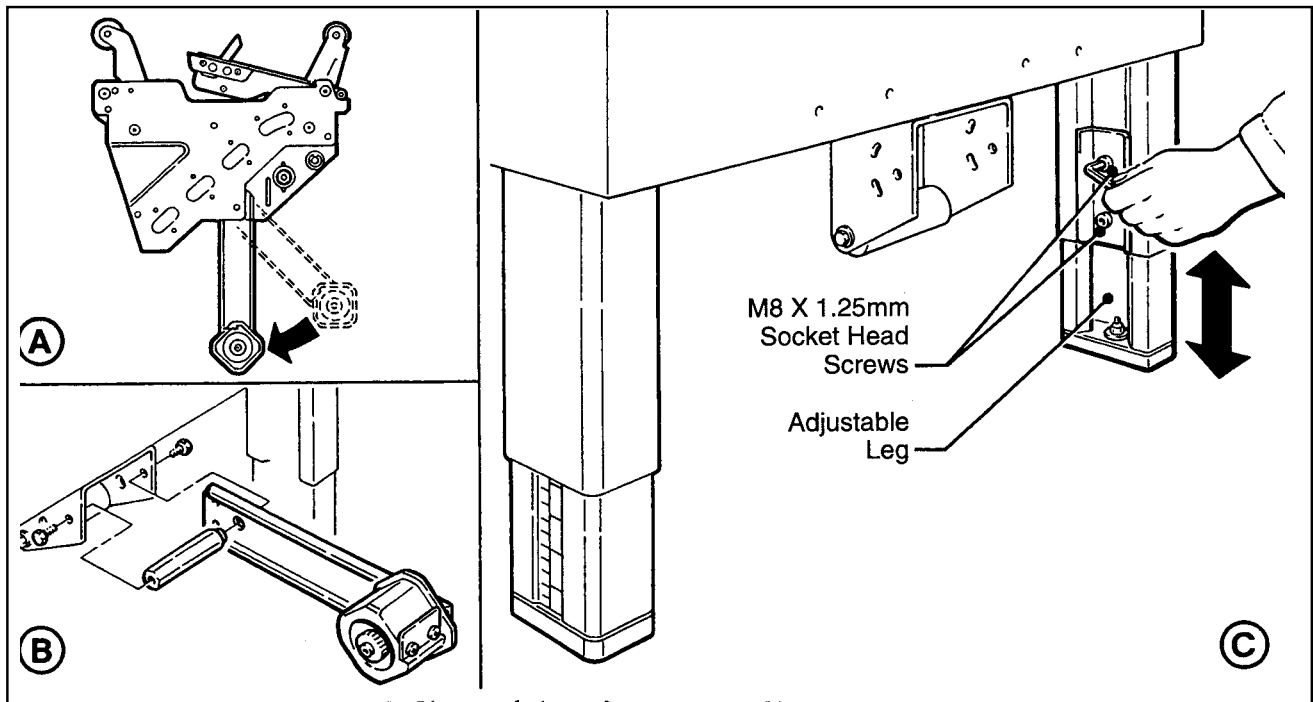

Figure 2-2 – Machine Bed Height Adjustment and Lower Tape Drum Bracket Position

Installation and Set-Up (Continued)

BOX SIZE CAPACITY OF CASE SEALER

At its factory setting, the case sealer handles box sizes up to 620 mm [24.5 in] maximum height. If larger capacity is needed, the machine can be adjusted to accommodate boxes up to 725 mm [28.5 in] high. Refer to "Special Set-Up Procedure – Box and Machine Bed Height Range", page 24. **Note – Adjusting machine to accommodate 725 mm [28.5 in] high boxes also increases minimum box size to 165 mm [6.5 in].**

Use of an extension cord is not recommended. However, if one is needed for temporary use, it must have a wire size of AWG 16 [1.5 mm dia], have a maximum length of 30.5 m [100 ft], and must be properly grounded.



WARNING – To prevent shock and fire hazard: Position extension cord where it will be out of the way of foot or vehicle traffic. Extension cord is only for temporary use – do not use for a permanent installation.

ELECTRICAL CONNECTION AND CONTROLS

The electrical control box, located on the lower right side of the machine frame, contains the pre-set circuit breaker. The control box can be located on the opposite side of the machine frame if desired.

A standard three conductor power cord with plug is provided at the back of the electrical control box for 115 Volt, 60 Hz., 1.9 Amp electrical service. The receptacle providing this service shall be properly grounded. Before the power cord is plugged into 115 Volt, 60 Hz outlet make sure that all packaging materials and tools are removed from the machine. **Do not plug electrical cord into outlet until ready to run machine.**

Note – Machines outside the U.S. may be equipped with 220/240 Volt, 50 Hz systems or other electrical requirements compatible with local practice.

INITIAL START-UP OF CASE SEALER

After completing the "Installation and Set-Up" procedure, continue through "Operation" for tape loading and start-up to be sure case sealer is properly adjusted to run boxes

Operation

IMPORTANT – Before operating the case sealer, read the "Important Safeguards", pages 3-5 and "Warnings" on page 14 as well as all of the "Operation" instructions.

Refer to Figure 3-1 below to acquaint yourself with the various components and controls of the case sealer. Also see Figures 3-1 and 3-2 in Section II for taping head components.

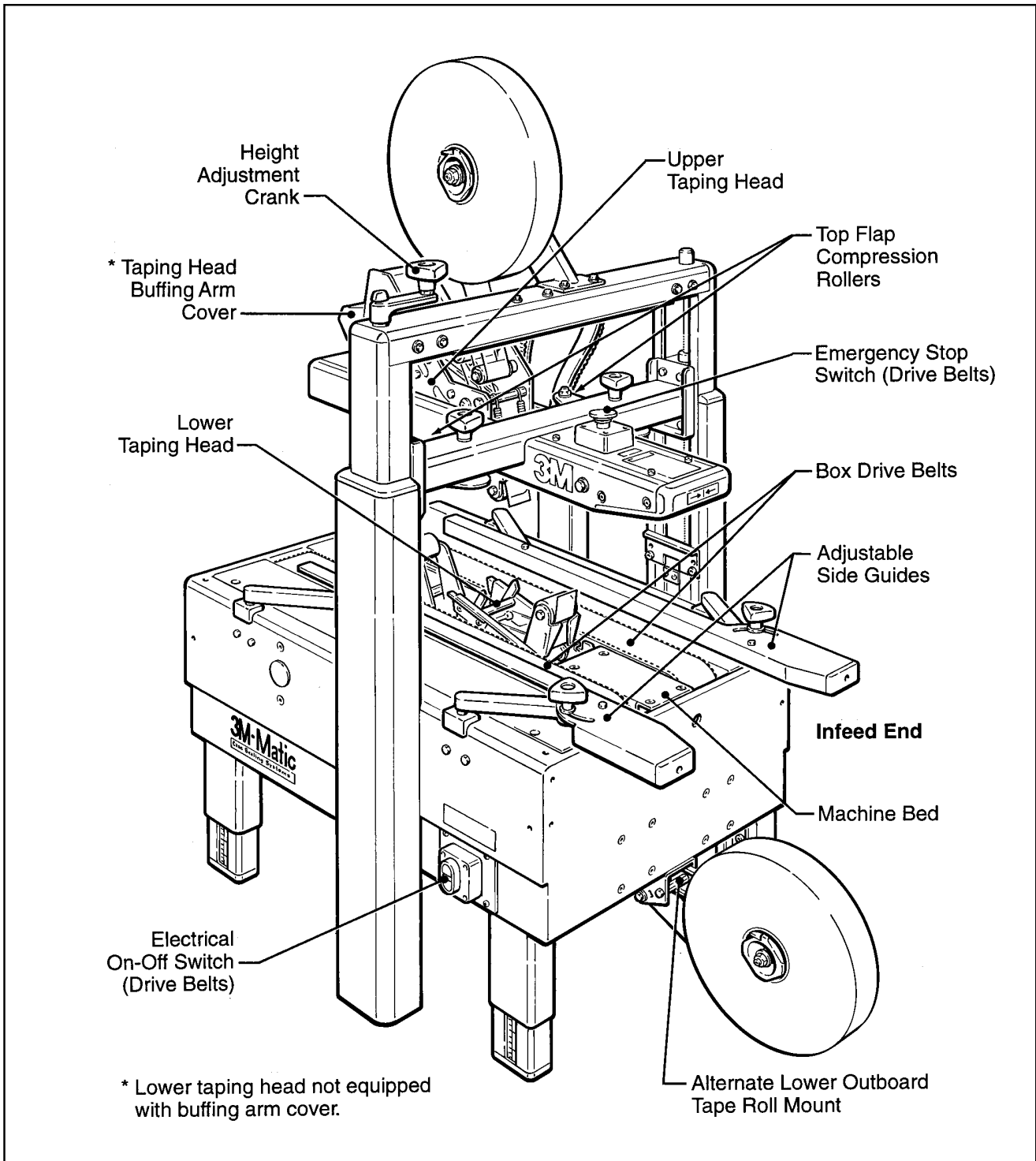

Figure 3-1 – 200a Case Sealer Components (Left Front View)

Operation (Continued)

WARNINGS

1. Turn electrical supply off and disconnect before servicing taping heads or performing any adjustments or maintenance on the machine.
2. Do not leave machine running unattended.
3. Before turning drive belts on, be sure no tools or other objects are on the machine bed.
4. Keep hands and loose clothing away from moving belts.
5. Keep hands and clothing away from taping heads when machine is running. A box traveling through the machine causes taping head rollers to retract when box enters and extend as box leaves taping head.
6. Never attempt to work on any part of the machine, load tape or remove jammed boxes from the machine while machine is running.
7. When feeding boxes to the machine by hand, push box in from end only – DO NOT PUSH WITH HANDS ON ANY CORNER OF THE BOX.
8. Both the upper and lower taping heads utilize extremely sharp knives. The knives are located under the orange knife guard which has the "WARNING – SHARP KNIFE" label. Before loading tape, refer to Figures 3-1 and 3-2 in Section II to identify the knife location. Keep hands out of these areas except as necessary to service the taping heads.
9. Turn drive belts "Off" when machine is not in use.
10. Failure to comply with these warnings could result in severe personal injury and/or equipment damage.

Electrical "On/Off" Switch

The box drive belts are turned on and off ("Off" button is red) with the electrical switch on the side of the machine frame.

Note – The case sealer has a circuit breaker located in the electrical control box on the lower right side of the machine frame. If circuit becomes overloaded and circuit breaker trips, see "Maintenance – Circuit Breaker", page 18.

Emergency Stop Switch

The machine electrical supply can be turned off by pressing the latching emergency stop switch. To restart machine, rotate emergency stop switch (releases switch latch) and then restart machine by pressing "I" (On) button on side of machine frame.

Tape Loading/Threading

See Section II, Pages 7 and 8

Note – If lower tape drum is mounted in alternate lower outboard position, remove taping head from machine bed by pulling straight up, insert threading needle in taping head and replace taping head. Install tape roll on drum (adhesive on tape leg up), thread tape under knurled roller on outboard mount, then attach tape to threading needle and pull tape through taping head with threading needle.

 **CAUTION** – Taping head weighs approximately 7.2 kg [16 pounds] without tape. Use proper body mechanics when removing or installing taping head.

Operation (Continued)

Box Size Set-Up

1. ADJUST UPPER TAPING HEAD

The upper taping head is positioned for the box height by means of the height adjustment crank shown in Figure 3-2. Turn crank clockwise to lower head, counterclockwise to raise head.

Place box on infeed end of machine bed with both top and bottom flaps folded and insert under upper head ski approximately 150 mm [6 inch] as shown in Figure 3-3. Lower the head until all flaps are fully closed.

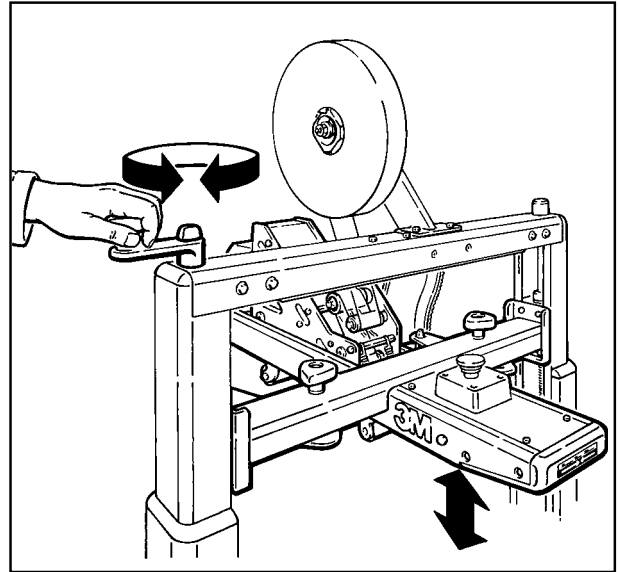

Figure 3-2 – Upper Taping Head

2. ADJUST SIDE GUIDES (Figure 3-4)

Align box top flap center seam with arrows on front of ski.

Move side guides against each side of box to hold box in position, centered on arrows on front of ski.

Tighten hand knobs to secure side guides.

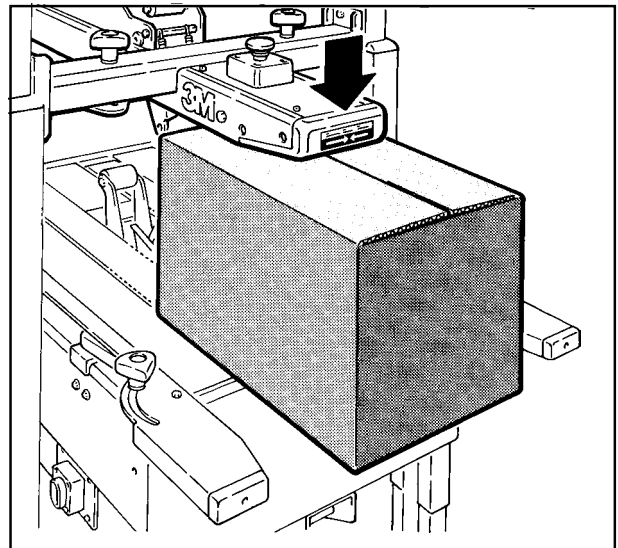

Figure 3-3 – Upper Taping Head

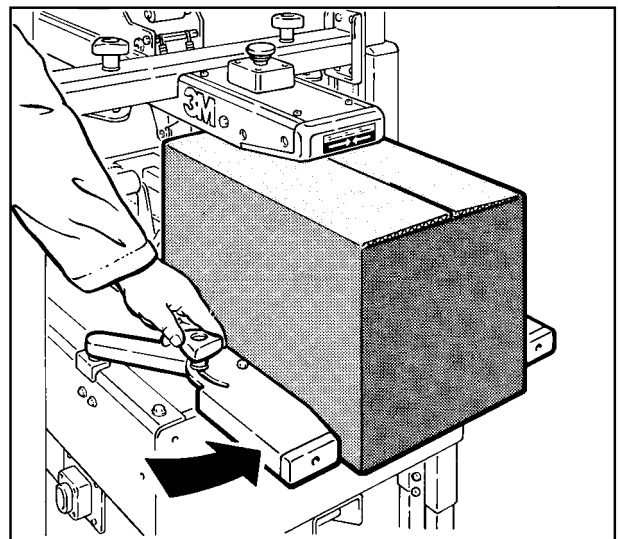

Figure 3-4 – Side Guides

Operation (Continued)

3. RUN BOXES TO CHECK ADJUSTMENT (Figure 3-5)

Turn electrical switch to "On" to start drive belts. Move box forward under upper taping head until it is taken away by drive belts. If box is hard to move under head or is crushed, **raise** head slightly. If box movement is jerky or stops under upper head, **lower** upper head slightly to add more pressure between box and drive belts.

Note – Upper head has unique feature for overstuffed boxes. The head will raise up to 13 mm [1/2 inch] to compensate for this type of condition.



CAUTION – If drive belts are allowed to slip on box, excessive belt wear will occur.

4. POSITION COMPRESSION ROLLERS (Figure 3-6)

Push box into machine and alternately turn "On/Of" switch "On" and "Off" until box is positioned where flap compression rollers can be adjusted against top edge of box.

Pivot both flap compression rollers against top edge of box and lock in place with hand knobs.

Turn electrical switch "On" and run box through machine.

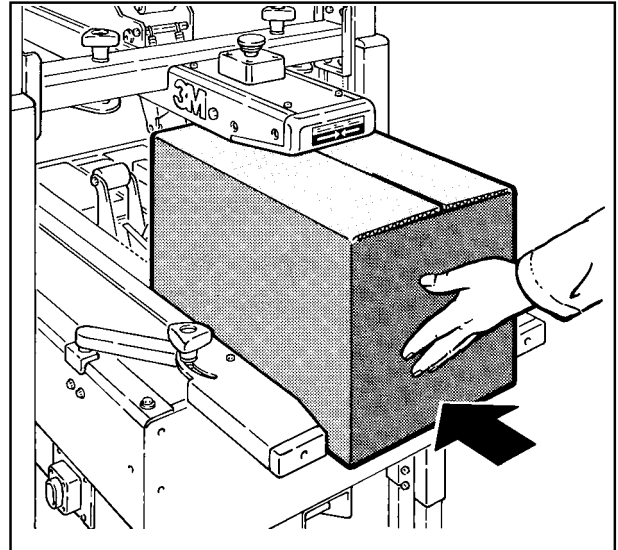

Figure 3-5 – Check Adjustments

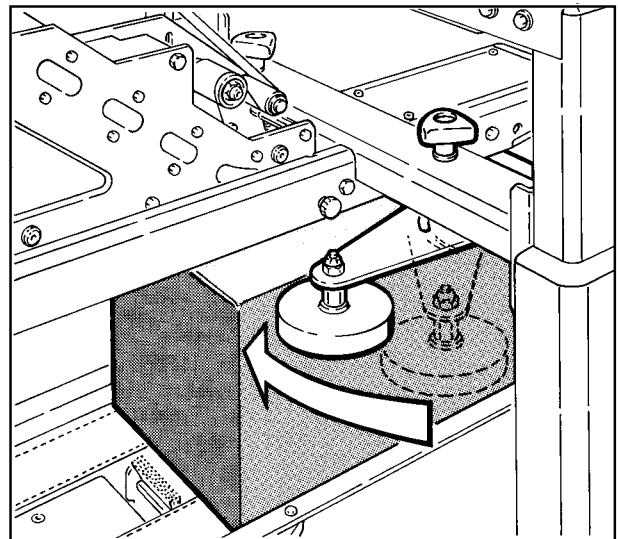

Figure 3-6 – Compression Rollers

Box Sealing

1. Feed boxes to machine at minimum 455 mm [18 inch] intervals.
2. Turn electrical supply "Off" when machine is not in use.
3. Reload and thread tape as necessary.
4. Be sure machine is cleaned and lubricated according to recommendations in "Maintenance" section of this manual.

Notes –

1. Machine or taping head adjustments are described in "Adjustments" Section I for machine or Section II for taping heads.
2. Box drive motors are designed to run at a moderate temperature of 40°C [104°F]. In some cases, they may feel hot to the touch.

Maintenance

The case sealer has been designed for long, trouble free service. The machine will perform best when it receives routine maintenance and cleaning. Machine components that fail or wear excessively should be promptly repaired or replaced to prevent damage to other portions of the machine or to the product.

WARNING – Turn off electrical power supply and disconnect power cord from electrical supply before beginning maintenance. If electrical power is not disconnected, severe injury to personnel could result.

Cleaning

Note – Never attempt to remove dirt from taping heads by blowing it out with compressed air. This can cause the dirt to be blown inside the motor and onto sliding surfaces which may cause premature equipment wear. Never wash down or subject equipment to conditions causing moisture condensation on components. Serious equipment damage could result.

Regular slotted containers produce a great deal of dust and paper chips when processed or handled in equipment. If this dust is allowed to build-up on machine components, it can cause component wear and overheating of drive motor. The dust build-up can best be removed from the machine by a shop vacuum. Depending on the number and type of boxes sealed in the case sealer, this cleaning should be done approximately once per month. If the boxes sealed are dirty, or if the environment in which the machine operates is dusty, cleaning on a more frequent basis may be necessary. Excessive dirt build-up that cannot be removed by vacuuming should be wiped off with a damp cloth.

Lubrication

Most of the machine bearings, including the drive motor, are permanently lubricated and sealed and do not require additional lubricant.

Figure 4-1 illustrates the machine points that do require lubrication every 250 hours of operation. Lubricate the points indicated by arrows () with a small amount of multi-purpose grease.

Note – Wipe off excess oil and grease. It will attract dust which can cause premature equipment wear and jamming. Take care that oil and grease are not left on the surface of rollers around which tape is threaded, as it can contaminate the tape's adhesive.

TAPING HEAD LUBRICATION – See Section II, "Maintenance – Lubrication", page 10.

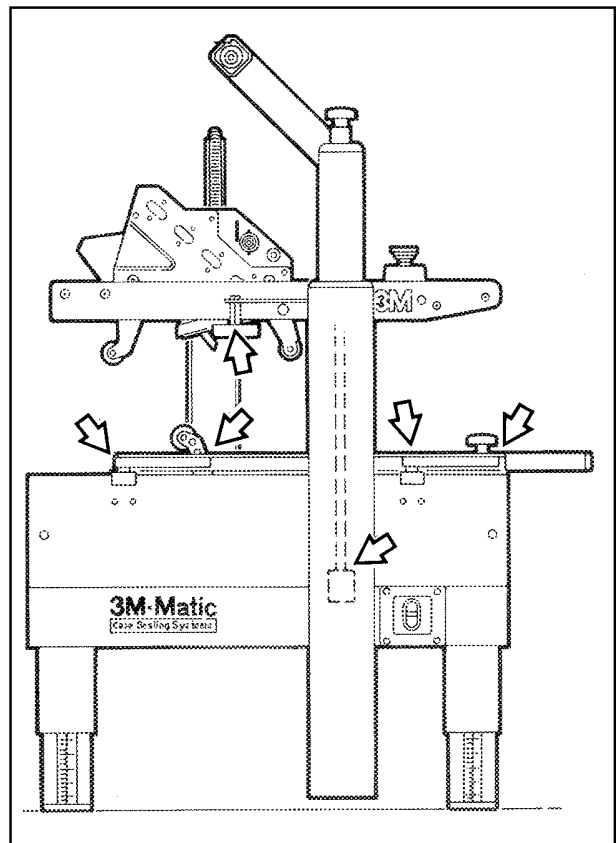

Figure 4-1 – Lubrication Points – Frame

Maintenance (Continued)

WARNING – Turn off electrical power supply and disconnect power cord from electrical supply before beginning maintenance. If power cord is not disconnected, severe injury to personnel could result.

Circuit Breaker

The case sealer is equipped with a circuit breaker which trips if the motor is overloaded. The circuit breaker is located inside the electrical control box on the side of machine frame just below the machine bed.

WARNING – The following procedure must be performed by trained service personnel because of the high voltage electrical hazard within the control box.

If circuit is overloaded and circuit breaker trips, unplug machine from electrical power:

1. Determine cause of overload and correct.
2. Remove electrical enclosure cover.
3. Lift circuit breaker switch to reset. If circuit breaker will not reset, wait 2 minutes and retry.
4. Replace cover.
5. Plug in machine.
6. Press machine "On" button to resume case sealing.

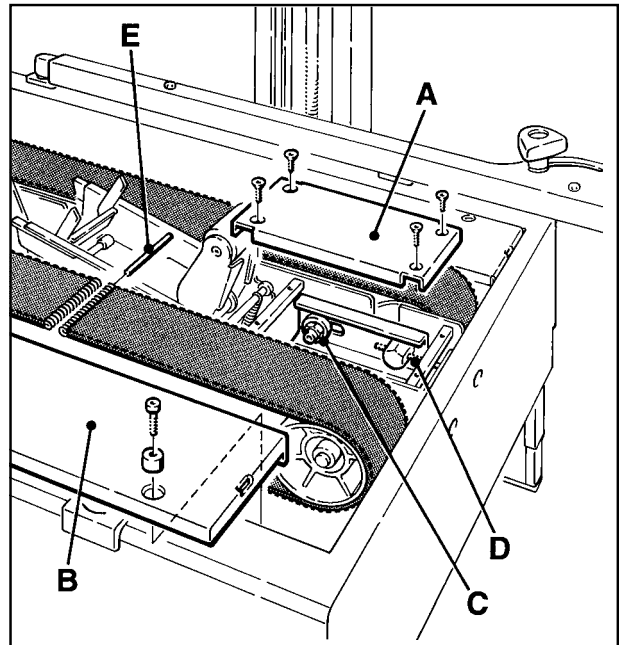

Figure 4-2 – Box Drive Belt Replacement

Knife Replacement, Taping Head

See Section II, "Maintenance – Knife Replacement", page 9.

Box Drive Belt Replacement

Figure 4-2

Note – 3M recommends the replacement of drive belts in pairs, especially if belts are unevenly worn.

To remove old belt:

1. Remove and retain center plate (A) and four screws.
2. Remove and retain side cover (B) and fasteners.
3. Loosen, but do not remove lock nut (C).
4. Loosen tension screw (D) until all belt tension is removed.
5. Pull belt splicing pin (E) out and remove belt.
6. Place new belt over pulleys with laced splice at top. Insert splicing pin. **Note - Pin must not extend beyond edge of belt.**
7. Adjust belt tension as explained in "Adjustments - Box Drive Belt Tension", Page 19.
8. Replace side cover and center plate and secure with original fasteners.

Adjustments



WARNING – Turn off electrical power supply and disconnect power cord from electrical supply before beginning adjustments. If power cord is not disconnected, severe injury to personnel could result.

Box Drive Belt Tension

The two continuously moving drive belts convey boxes through the tape applying mechanism. The box drive belts are powered by an electric gear motor.

Tension adjustment of these belts may be required during normal operation. Belt tension must be adequate to positively move the box through the machine and the belts should run fully on the surface of the pulleys at each end of the frame. The idler pulleys on the infeed end are adjusted in or out to provide proper belt tension. Each belt is adjusted separately.

Belt tension is obtained by tightening the adjustment screw so that a moderate pulling force of 3.5 kg [7.5 lbs.] applied at the midspan, as shown in Figure 5-1, will deflect the belt 25 mm [1 inch]. This will assure positive contact between the belt and the drive pulley on the discharge end of the taping head.

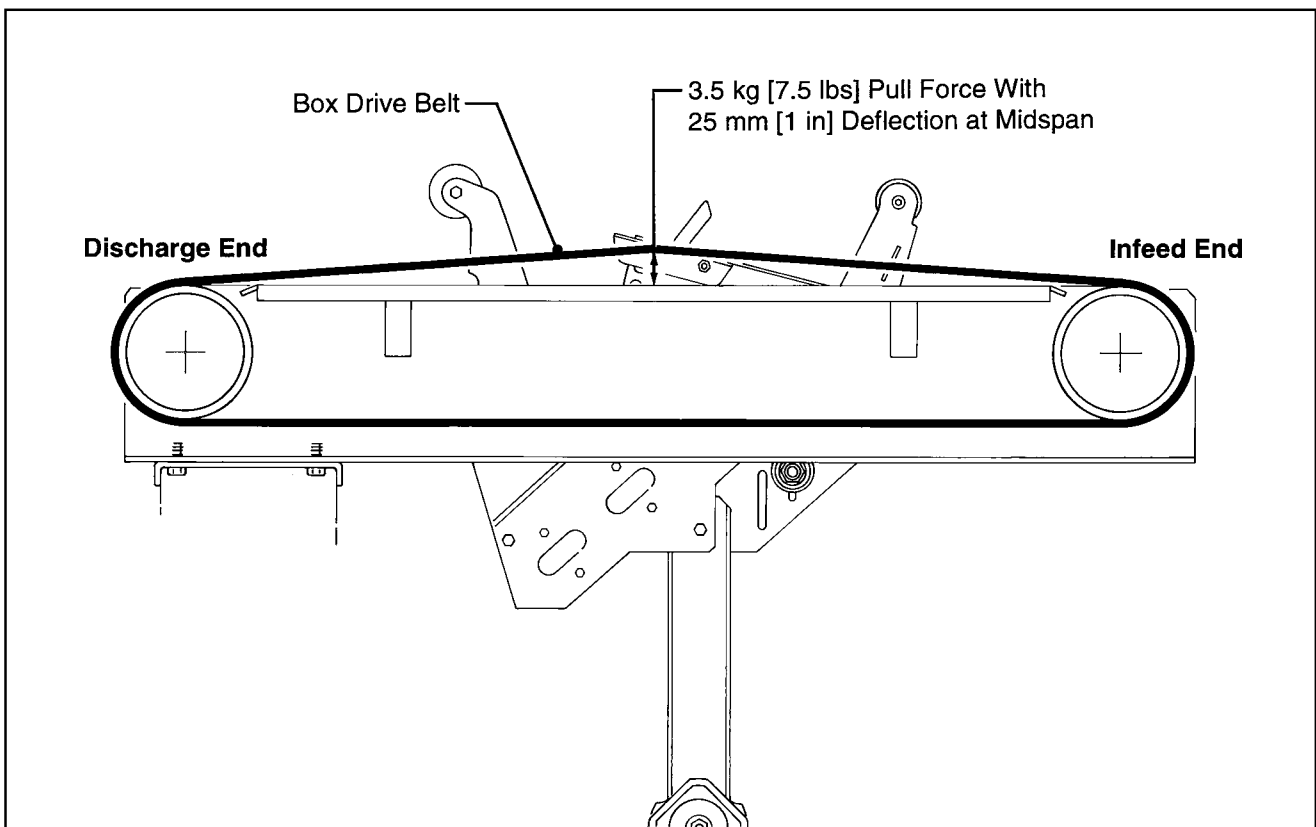

Figure 5-1 – Box Drive Belt Tension Adjustment

Adjustments (Continued)



WARNING – Turn off electrical power supply and disconnect power cord from electrical supply before beginning adjustments. If power cord is not disconnected, severe injury to personnel could result.

Refer to Figure 5-2 and adjust belt tension as follows:

1. Remove and retain center plate and four screws.
2. Loosen, but do not remove, M10 lock nut with a 17 mm open end wrench.
3. Reset the tension on the drive belt as needed. Use M6 hex wrench and adjust the M8 socket head tension screws in (clockwise) to **increase** tension or out (counterclockwise) to **decrease** tension. Tighten lock nut to secure tension setting.
4. Replace center plate and secure with original screws.

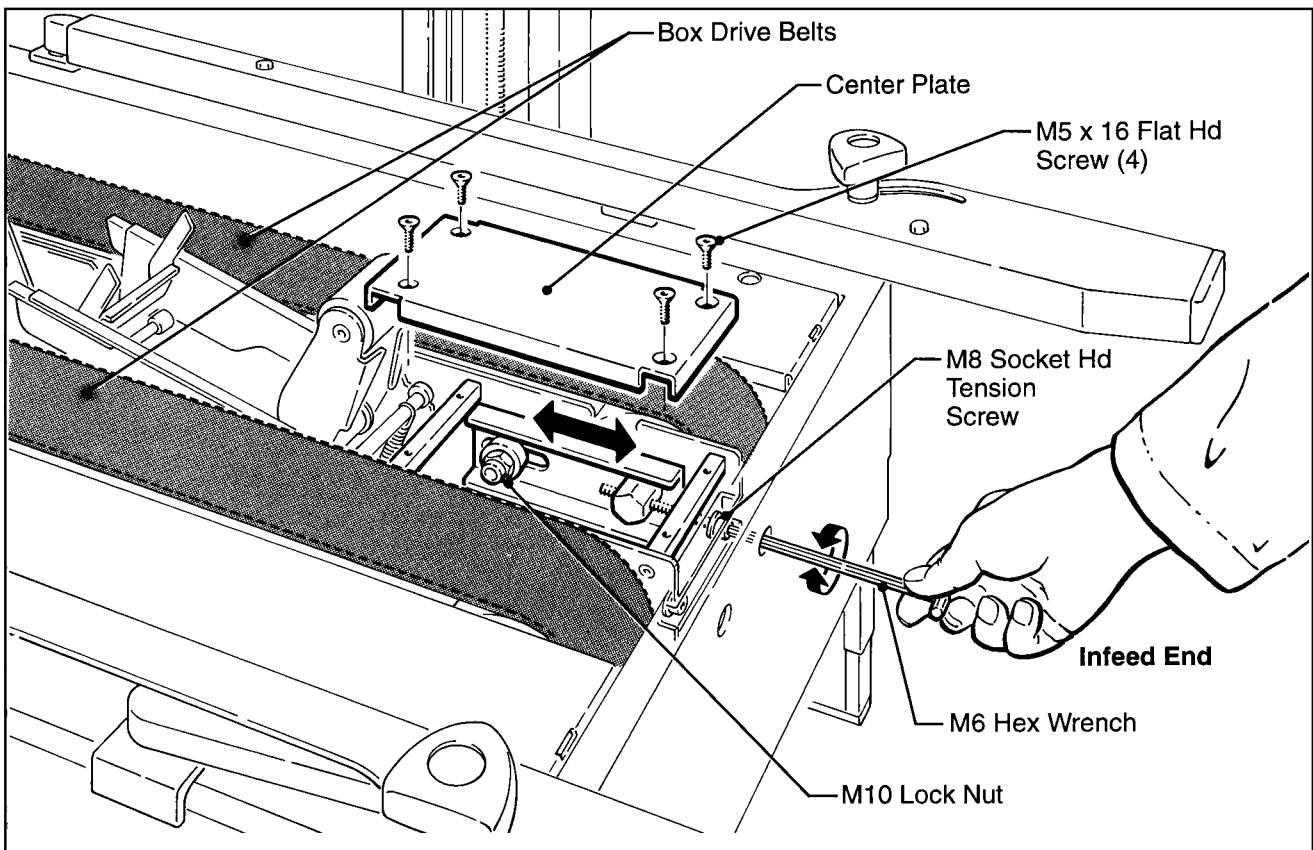

Figure 5-2 – Box Drive Belt Tension Adjustment (Machine Bed Infeed End)

Adjustments (Continued)



WARNING – Turn off electrical power supply and disconnect power cord from electrical supply before beginning adjustments. If power cord is not disconnected, severe injury to personnel could result.

Taping Head Adjustments – Refer to Section II



WARNING – Use care when working near tape cut-off knives on taping heads as knives are extremely sharp. If care is not taken, severe injury to personnel could result.

TAPE WEB ALIGNMENT – Section II, Page 11

TAPE DRUM FRICTION BRAKE – Section II, Page 11

APPLYING MECHANISM SPRING – Section II, Page 12

ONE-WAY TENSION ROLLER – Section II, Page 12

THIS PAGE IS BLANK

Special Set-Up Procedure

⚠ WARNING – Turn off electrical power and disconnect power cord from electrical supply before beginning Special Set-Up Procedure. If power cord is not disconnected, severe injury to personnel could result.

Changing the Tape Leg Length

(From 70 to 50 mm [2-3/4 to 2 inch])

The following changes to the case sealer frame and upper/lower taping heads will allow the taping of boxes 90 mm [3.5 inch] minimum height.

CASE SEALER FRAME

(Refer to Figure 6-1A)

1. Raise the upper head assembly by turning crank handle counterclockwise. Remove and retain the two stop bracket screws and washers from the normal position holes "A-A".
2. Move stop bracket down and secure with original fasteners through upper holes "A" in stop bracket. Relocate both right and left stop brackets.

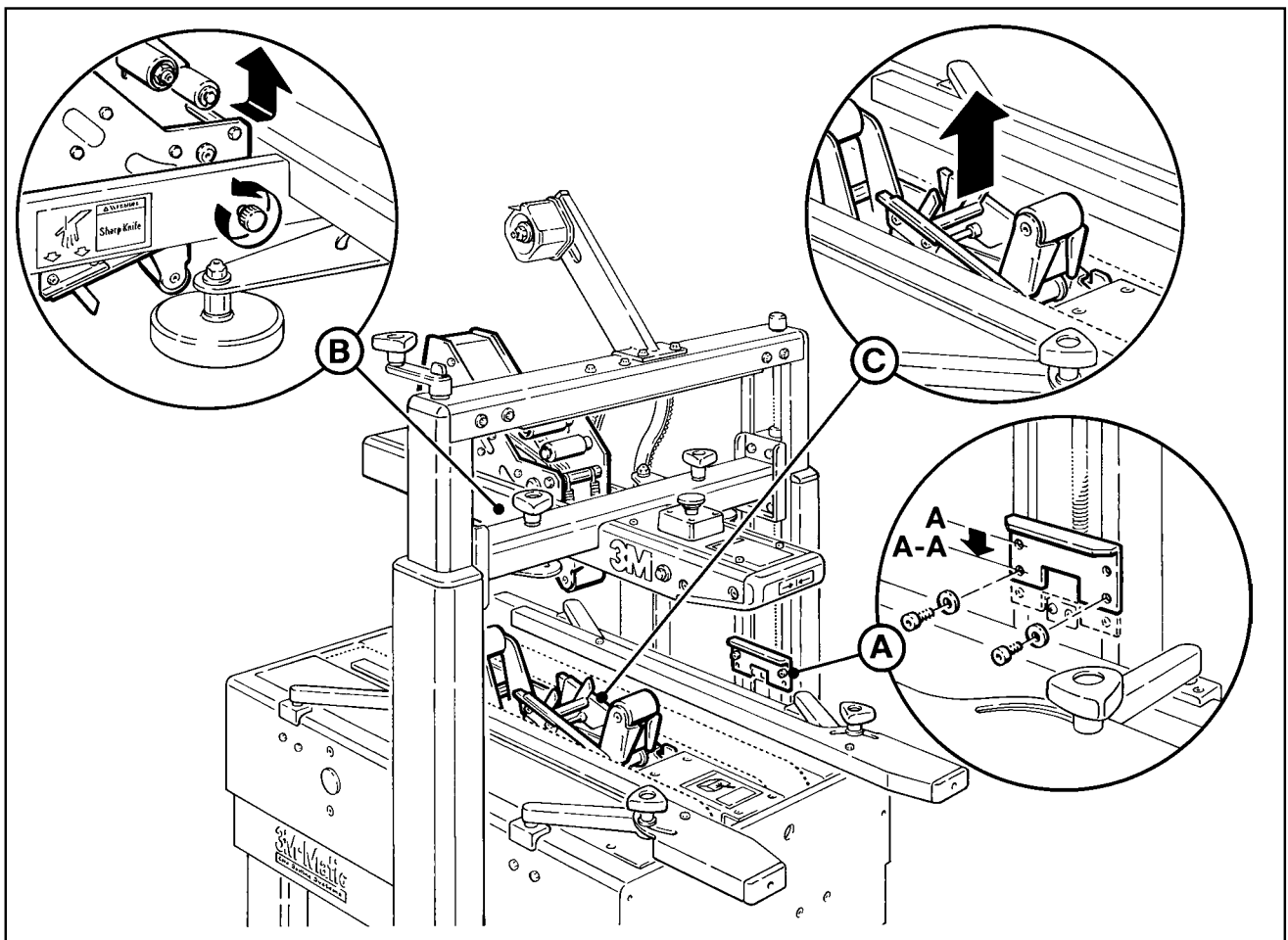

Figure 6-1 – Case Sealer Frame Changes

Special Set-Up Procedure (Continued)



WARNING – Turn off electrical power and disconnect power cord from electrical supply before beginning Special Set-Up Procedure. If power cord is not disconnected, severe injury to personnel could result.

TAPING HEADS



WARNING – Use care when working near knives as knives are extremely sharp. If care is not taken, severe injury to personnel could result.

1. Loosen, but do not remove, the two retaining screws that secure the upper taping head shown in Figure 6-1B.
2. Slide the head forward and lift straight up to remove it from the case sealer.



CAUTION – Taping head weighs approximately 7.2 kg [16 lbs]. Use proper body mechanics when lifting upper or lower taping heads.

3. Lift the lower taping head, shown in Figure 6-1C, straight up to remove it from the case sealer bed.
4. Refer to Section II, "Adjustments – Changing Tape Leg Length", page 13 for taping head set-up.

Box and Machine Bed Height Range – Refer to Figure 6-2

Moving the outer columns up one set of mounting holed increases the maximum box size handled by the 200a case sealer and decreases the minimum machine bed height.

Note – This also increases the minimum box height from 120 mm [4.75 inch] to 165 mm [6.5 inch].

To move the outer columns up one set of mounting holes:

1. Place minimum 305 mm [12 inch] high blocks at the front and rear of the upper taping head assembly as shown in Figure 6-2A. **Important – Blocks (front and rear) must be same height in order to keep upper taping head assembly parallel with machine bed/drive belts.** Crank the upper taping head assembly down until it touches these blocks.
2. Remove and retain the six screws and plain washers that fasten each column to the frame. Figure 6-2B.
3. Turn the height adjustment crank clockwise to raise the outer columns up one set of mounting holes (100 mm [4 inch]).



WARNING – Blocks and spacers must be capable of supporting the 34 Kg [75 pound] weight of the outer columns and upper taping head assembly.

4. Install and tighten the six screws and plain washers in each column that were removed in Step 2. Crank upper taping head assembly up and remove blocks.

If desired, the bed height can now be decreased to 520 mm [20.5 inch] by adjusting legs upward. (See "Installation and Set-Up – Machine Bed Height", Page 11.)

Special Set-Up Procedure (Continued)

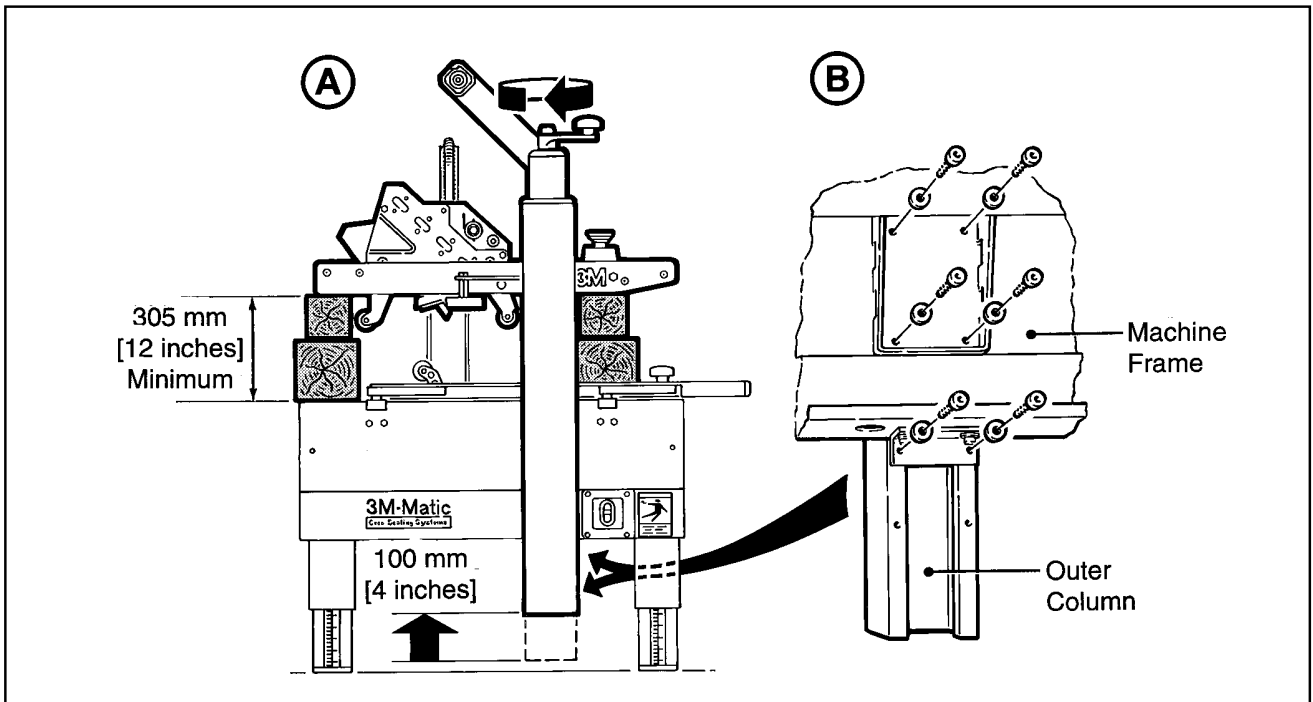

Figure 6-2 – Box and Machine Bed Height Range

THIS PAGE IS BLANK

Troubleshooting

The Troubleshooting Guide lists some possible machine problems, causes and corrections. Also see Section II "Troubleshooting", pages 15 and 16 for taping head problems.

Troubleshooting Guide

Problem	Cause	Correction
Drive belts do not convey boxes	Narrow boxes	Check machine specifications. Boxes are narrower than recommended, causing slippage and premature belt wear.
	Worn drive belts	Replace drive belts
	Top taping head does not apply enough pressure	Adjust the box height adjustment with the crank
	Top flap compression rollers in too tight	Readjust compression rollers
	Taping head applying spring holder missing	Replace spring holder
Drive belts do not turn	Taping head applying spring set too high	Reduce spring pressure
	Worn or missing friction rings	Replace friction rings
	Drive belt tension too low	Adjust belt tension
	Electrical disconnect	Check power and electrical plug
	Circuit breaker not at correct setting	Set to correct current value
Upper and lower applying mechanisms interfere with each other	Motor not turning	Evaluate problem and correct
	Machine's minimum height stop does not match tape head leg length setting	Check manual to make sure taping heads match machine setting
Drive belts break	Worn belt	Replace belt
Light boxes tip back on exit	Upper ski down too far	Carefully adjust upper ski
Squeaking noise as boxes pass through machine	Dry compression rollers	Lubricate compression rollers
	Dry column bearings	Lubricate column bearings
	Defective column bearings	Replace column bearings

Electrical Diagrams (Continued)

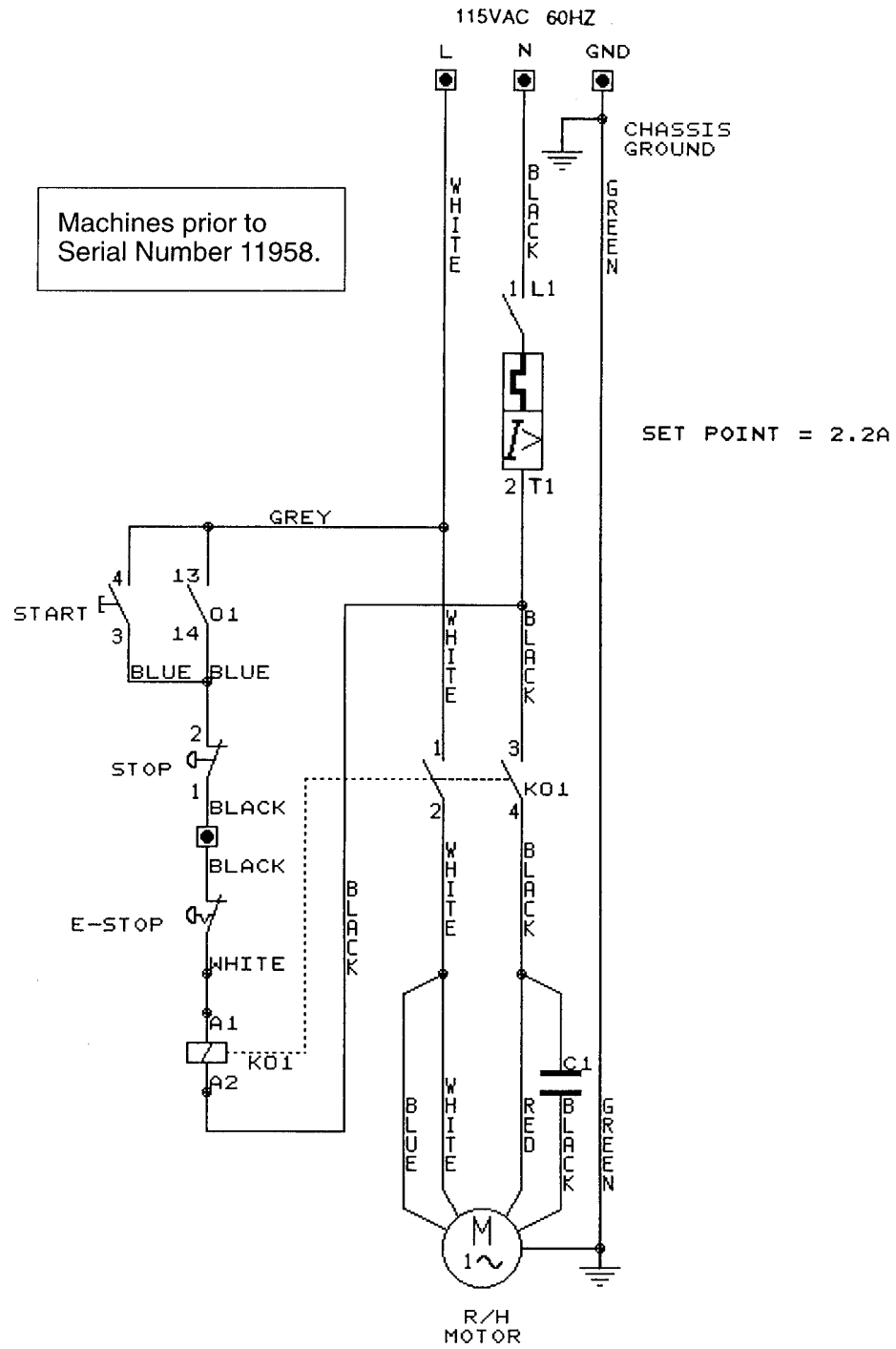

Figure 7-2

Electrical Diagrams (Continued)

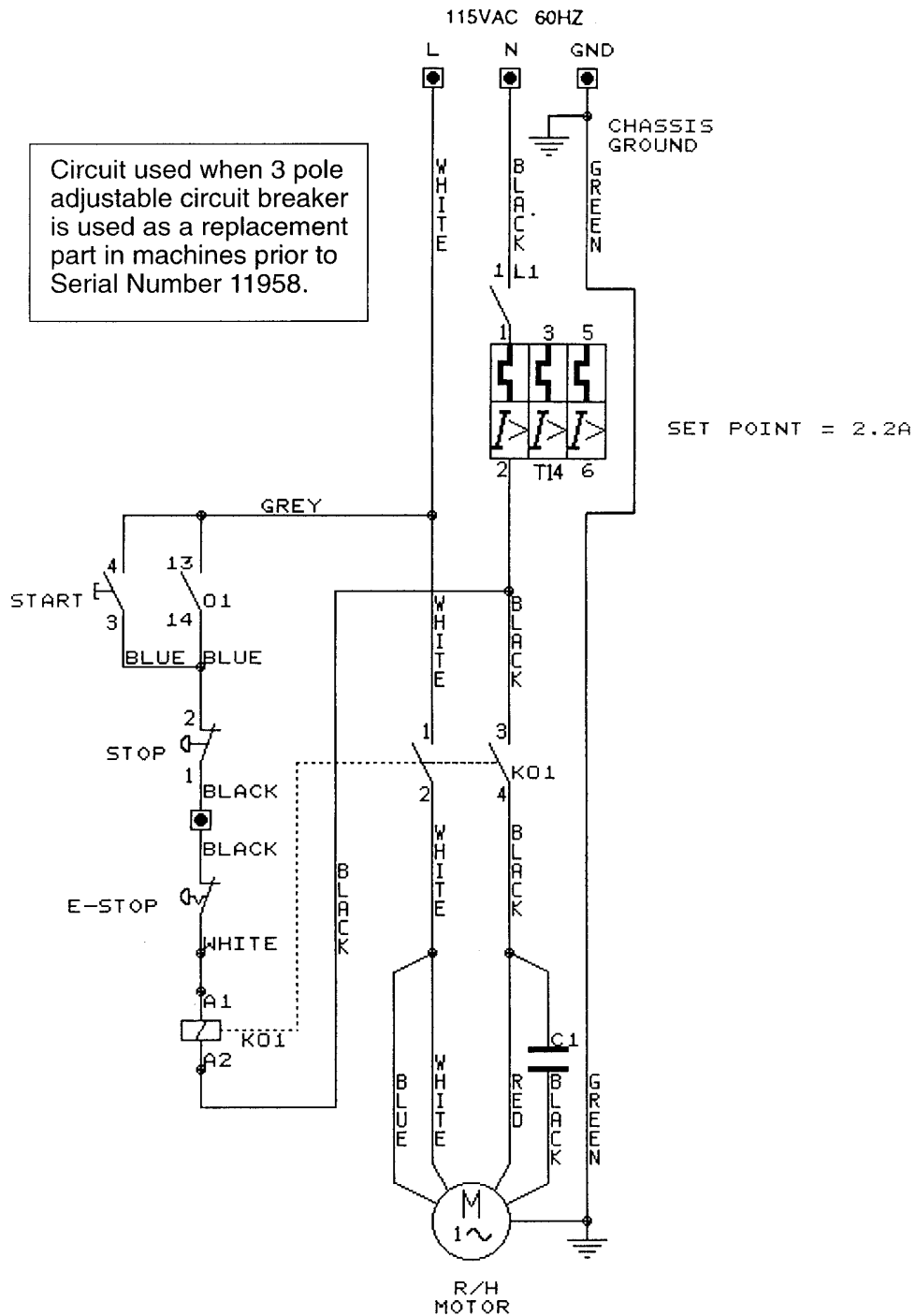

Figure 7-3

Replacement Parts and Service Information

Spare Parts

It is suggested that the following spare parts be ordered and kept on hand:

Qty.	Ref. No.	Part Number	Description
2	2795-39	78-8070-1531-4	Belt - Drive W/Pin

Label Kit

In the event that any labels are damaged or destroyed, **they must be replaced to ensure operator safety.** A label kit, part number 78-8113-6714-9, is available as a stock item. It contains all the safety labels used on the 200a Adjustable Case Sealer.

Tool Kit

A tool kit, part number 78-8060-8476-6, is available as a stock item. The kit contains the necessary open end and hex socket wrenches for use with the metric fasteners on the case sealer. The threading tool, part number 78-8076-4726-4, contained in above kit is also available as a replacement stock item.

Replacement Parts Ordering Information and Service

Refer to the first page of this instruction manual "Replacement Parts and Service Information.

Options/Accessories

For additional information on the options/accessories listed below, contact your 3M Representative.

Part Number	Option/Accessory
78-8052-6553-1	Box Hold Down Attachment, Model 18500
78-8069-3983-7	Caster Kit Attachment
78-8069-3924-1	Conveyor Extension Attachment
78-8069-3926-6	Low Tape Sensor Kit
78-8114-0828-1	AccuGlide™ II STD 2 Inch Upper Taping Head, Type 39600
78-8114-0829-9	AccuGlide™ II STD 2 Inch Lower Taping Head, Type 39600
78-8079-5505-5	Three Flap Folder Kit

Replacement Parts – Illustrations and Parts Lists

200a Adjustable Case Sealer, Type 39600
Frame Assemblies

To Order Parts:

1. Refer to first illustration, **Frame Assemblies**, page 35 for the **Figure Number** that identifies a specific portion of the machine.
2. Refer to the appropriate **Figure or Figures** to determine the parts required and the parts reference number.
3. The Parts List that follows each illustration, includes the **Reference Number, Part Number** and **Part Description** for the parts on that illustration.

Note – The complete description has been included for standard fasteners and some commercially available components. This has been done to allow obtaining these standard parts locally, if desired.

4. Order parts by **Part Number, Part Description** and **Quantity** required. Also include machine name, number and type.
5. Refer to the first page of this instruction manual “**Replacement Parts and Service Information**” for replacement parts ordering information.

IMPORTANT – Not all the parts listed are normally stocked items. Some parts or assemblies shown are available only on special order. Contact 3M/Tape Dispenser Parts to confirm item availability.

THIS PAGE IS BLANK

200a Adjustable Case Sealer

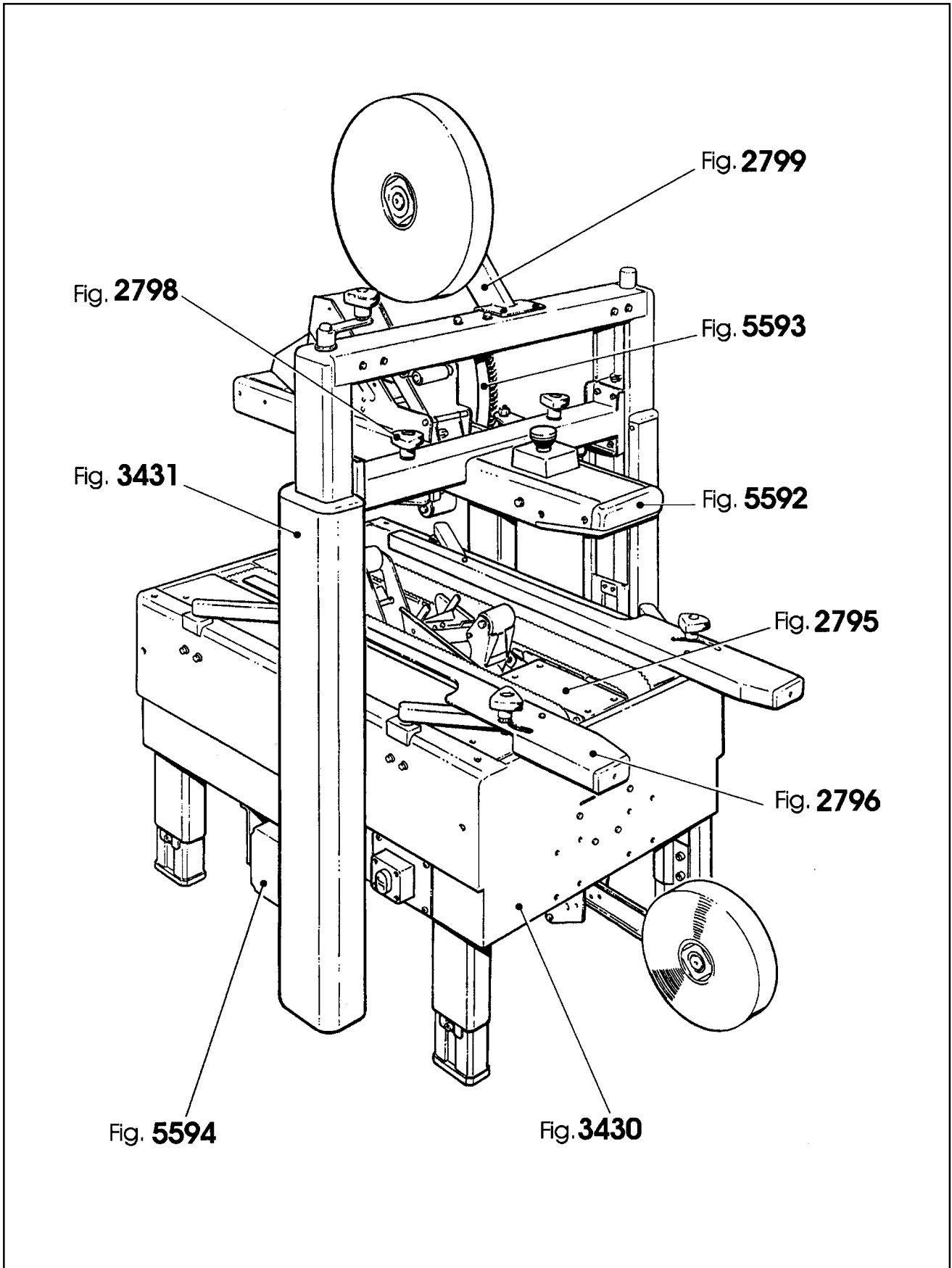

Frame Assemblies

200a Adjustable Case Sealer

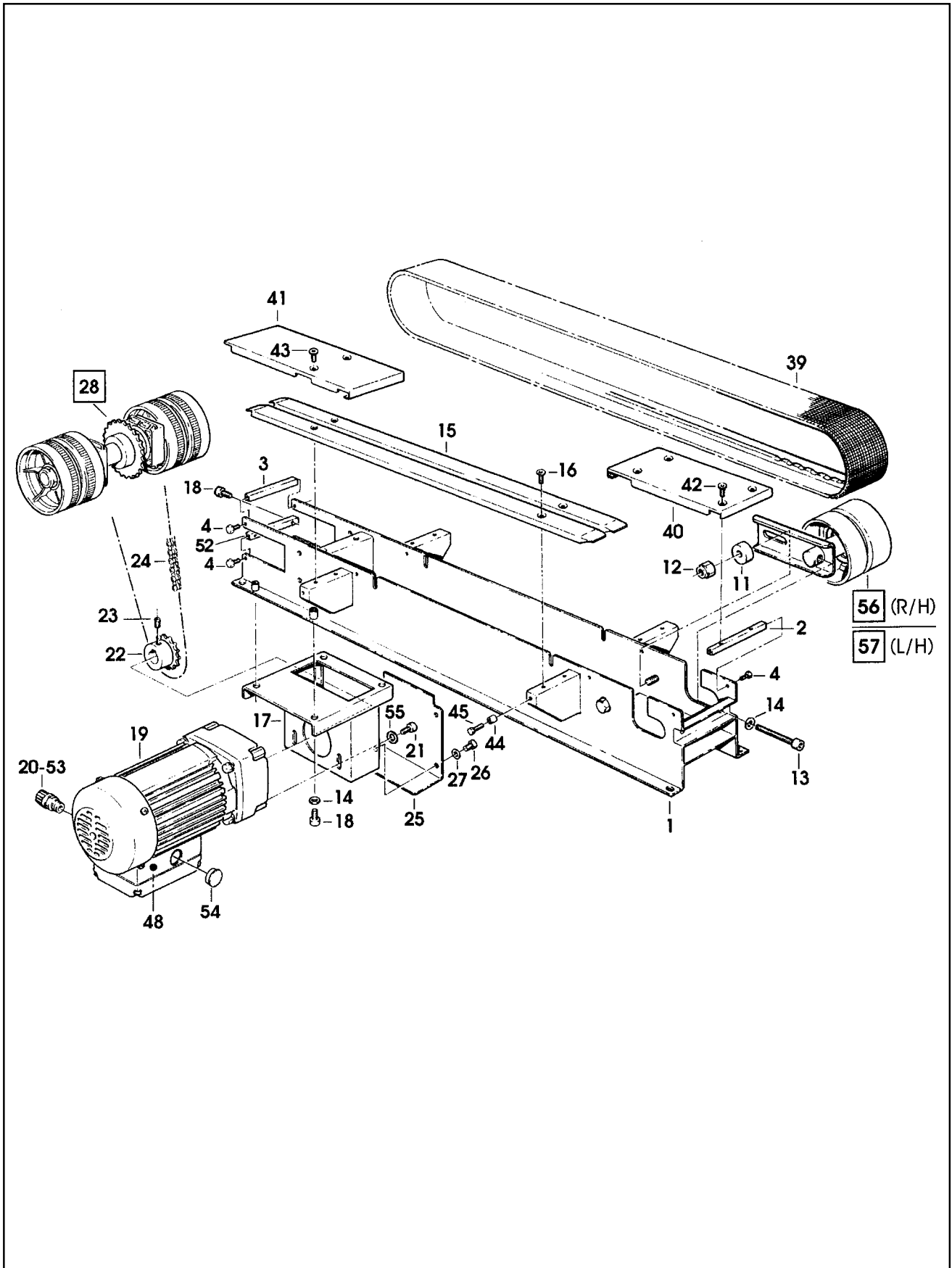

Figure 2795/1 of 2

Figure 2795 (Page 1 of 2)

Ref. No.	3M Part No.	Description
2795-1	78-8070-1513-2	Frame – Drive
2795-2	78-8070-1514-0	Spacer
2795-3	78-8070-1515-7	Spacer
2795-4	26-1003-5829-5	Screw – Hex Hd, M6 x 12
2795-7	78-8052-6710-7	Roller – Idler
2795-8	78-8052-6709-9	Washer – Special
2795-9	78-8010-7435-8	Washer – Lock, M6
2795-10	26-1003-7957-2	Screw – Soc Hd Hex Hd, M6 x 16
2795-11	78-8070-1518-1	Spacer – Shaft
2795-12	26-1003-6918-5	Nut – Hex Flange, M10, Plastic Insert
2795-13	78-8070-1519-9	Screw – Soc Hd Hex Hd, M8 x 70
2795-14	78-8017-9318-9	Washer – Plain 8 mm
2795-15	78-8070-1520-7	Guide – Drive Belt
2795-16	26-1005-4757-4	Screw – Flat Hd M5 x 20
2795-17	78-8070-1521-5	Support – Gearbox
2795-18	26-1003-7964-8	Screw – Soc Hd Hex Soc Dr, M8 x 20
2795-19	78-8070-1522-3	Gear Motor – 115V, 60HZ
2795-20	78-8076-4715-7	Cord – Grip
2795-21	78-8070-1523-1	Screw – 1/4-28 x 1/2 SHCS
2795-22	78-8070-1524-9	Sprocket – 3/8 inch
2795-23	78-8023-2479-4	Screw – Set M6 x 10, W/End Cup
2795-24	78-8070-1525-6	Chain – 3/8 inch, 54 Links

200a Adjustable Case Sealer

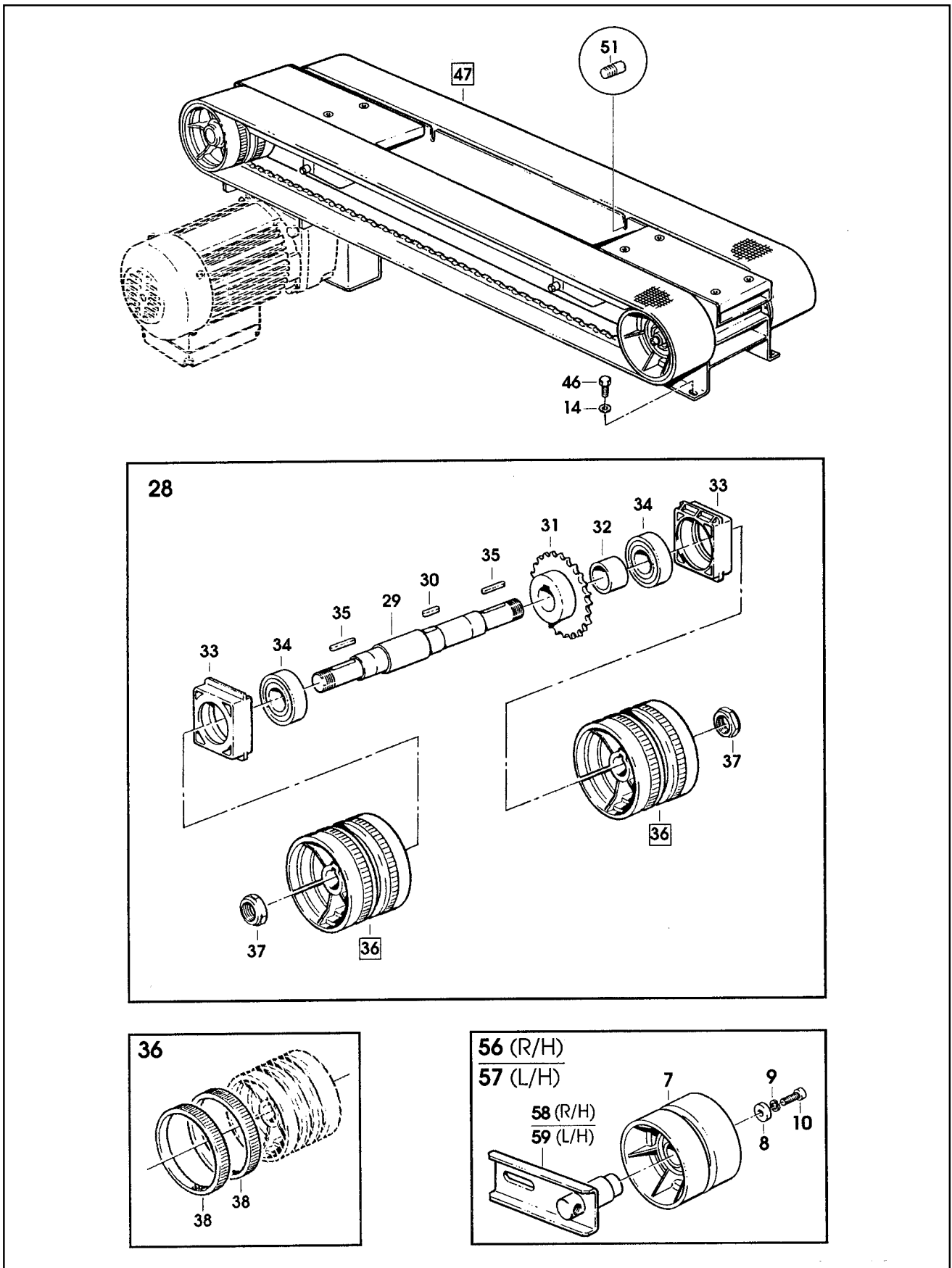

Figure 2795/2 of 2

Figure 2795 (Page 2 of 2)

Ref. No.	3M Part No.	Description
2795-25	78-8070-1526-4	Cover – Chain
2795-26	78-8010-7209-7	Screw – Soc Hd, M6 x 12
2795-27	26-1000-0010-3	Washer – Flat, M6
2795-28	78-8070-1527-2	Shaft – W/Drive Pulleys
2795-29	78-8070-1528-0	Shaft – Gearbox
2795-30	78-8057-5811-3	Key – 6 x 6 x 20 mm
2795-31	78-8054-8986-7	Sprocket – 3/8 inch Pitch, 28 teeth
2795-32	78-8054-8984-2	Bushing
2795-33	78-8070-1529-8	Support – Shaft
2795-34	78-8070-1530-6	Bearing – 6205-2RS
2795-35	78-8057-5739-6	Key – M5 x 5 x 30 mm
2795-36	78-8076-5105-0	Pulley Assembly – Drive
2795-37	78-8060-8416-2	Nut – Special, M20 x 1
2795-38	78-8052-6713-1	Ring – Polyurethane
2795-39	78-8070-1531-4	Belt – Drive W/Hook
2795-40	78-8070-1532-2	Plate – Front
2795-41	78-8113-6754-5	Cover – Rear, W/English Language Label
2795-42	26-0001-5862-1	Screw – Flat Hd Soc, M5 x 12
2795-43	26-1005-5316-8	Screw – Flat Hd Hex Dr, M5 x 16
2795-44	78-8070-1534-8	Stud – Side Plate
2795-45	78-8060-8488-1	Screw – Hex Hd, M5 x 20
2795-46	26-1003-5841-0	Screw – M8 x 16
2795-47	78-8070-1535-5	Bottom Drive Assembly
2795-48	26-1011-8828-7	Capacitor – 115V Gearmotor
2795-51	78-8076-4500-3	Stud – Mounting
2795-52	78-8094-6015-3	Spacer
2795-53	78-8076-5211-6	Set Nut – GMP13.5
2795-54	78-8060-7885-9	End Cap – /25X1,2
2795-55	78-8042-2919-9	Washer – Triple, M6
2795-56	78-8100-1236-5	Belt Tensioning Assembly – R/H
2795-57	78-8100-1237-3	Belt Tensioning Assembly – L/H
2795-58	78-8100-1238-1	Belt Tensioner – R/H
2795-59	78-8100-1239-9	Belt Tensioner – L/H

200a Adjustable Case Sealer

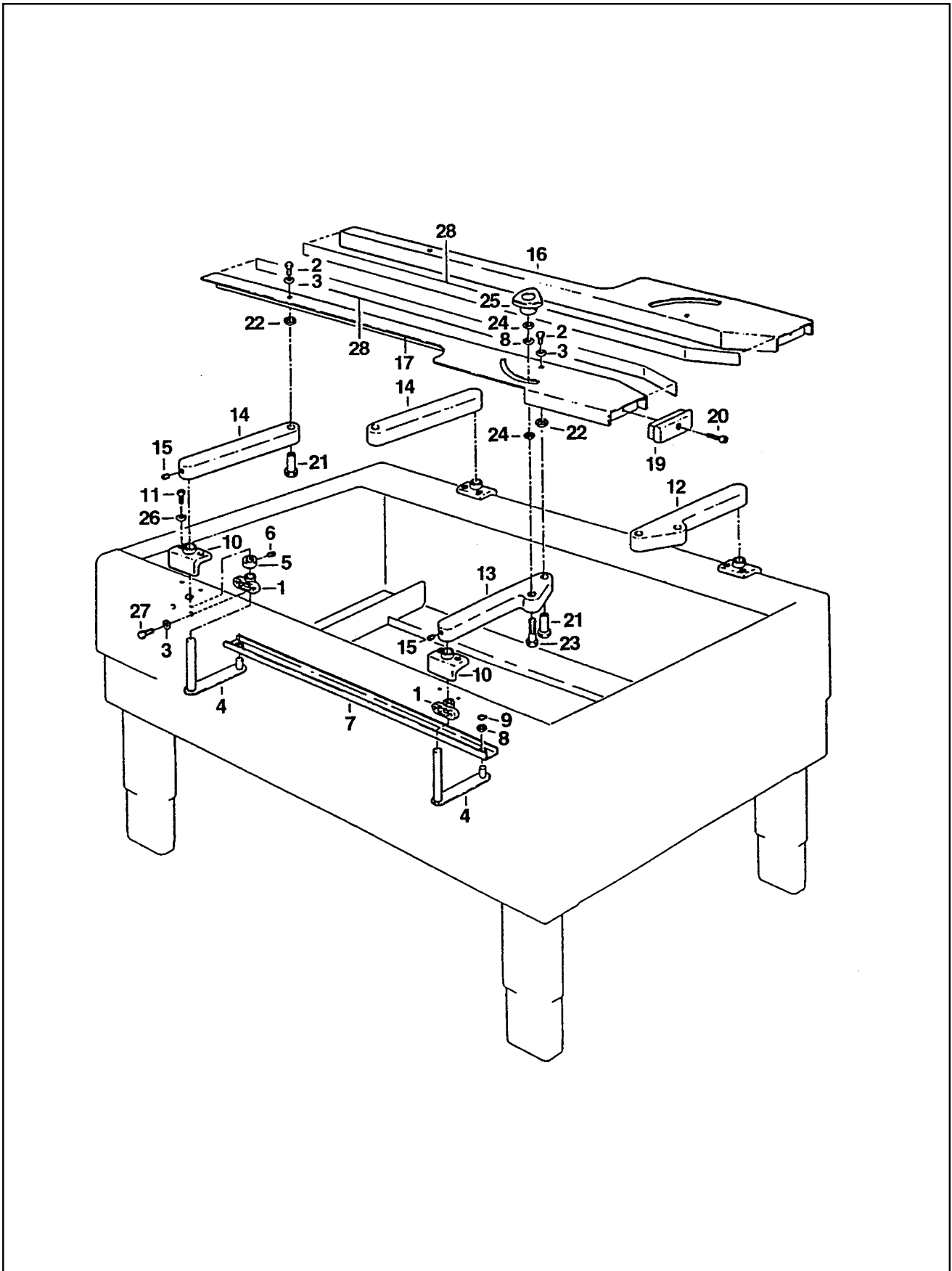

Figure 2796

Figure 2796

Ref. No.	3M Part No.	Description
2796-1	78-8070-1536-3	Support – Guide Arm
2796-2	78-8010-7169-3	Screw – Hex Hd, M6 x 12
2796-3	26-1000-0010-3	Washer – Flat, M6
2796-4	78-8070-1537-1	Lever With Pivot
2796-5	78-8070-1538-9	Bushing
2796-6	26-1003-8816-9	Screw – Set, M5 x 6
2796-7	78-8070-1539-7	Link – Guide
2796-8	78-8017-9074-8	Washer – 15 mm, Nylon
2796-9	78-8052-6733-9	Ring – M10, Special
2796-10	78-8070-1540-5	Support – Lever
2796-11	78-8032-0382-3	Screw – Soc Hd, M5 x 16
2796-12	78-8070-1541-3	Guide Arm – Front, Right
2796-13	78-8070-1542-1	Guide Arm – Front, Left
2796-14	78-8070-1543-9	Guide Arm – Rear
2796-15	78-8076-4505-2	Screw – Set, M6 x 8
2796-16	78-8070-1544-7	Guide – Right
2796-17	78-8070-1545-4	Guide – Left
2796-19	78-8070-1546-2	Cap – Guide
2796-20	26-1003-7953-1	Screw – Soc Hd, M5 x 30
2796-21	78-8070-1547-0	Shaft - Guide
2796-22	78-8070-1548-8	Washer – 20 x 12, 5 x 1 Nylon
2796-23	26-1003-5852-7	Screw – Hex Hd, M10 x 40
2796-24	78-8052-6566-3	Washer – Friction
2796-25	78-8070-1549-6	Knob – VTR-B-M10
2796-26	78-8005-5735-3	Washer – Lock, M5
2796-27	78-8032-0375-7	Screw – Hex Hd, M6 x 16
2796-28	78-8079-5378-7	Tape – Guide

200a Adjustable Case Sealer

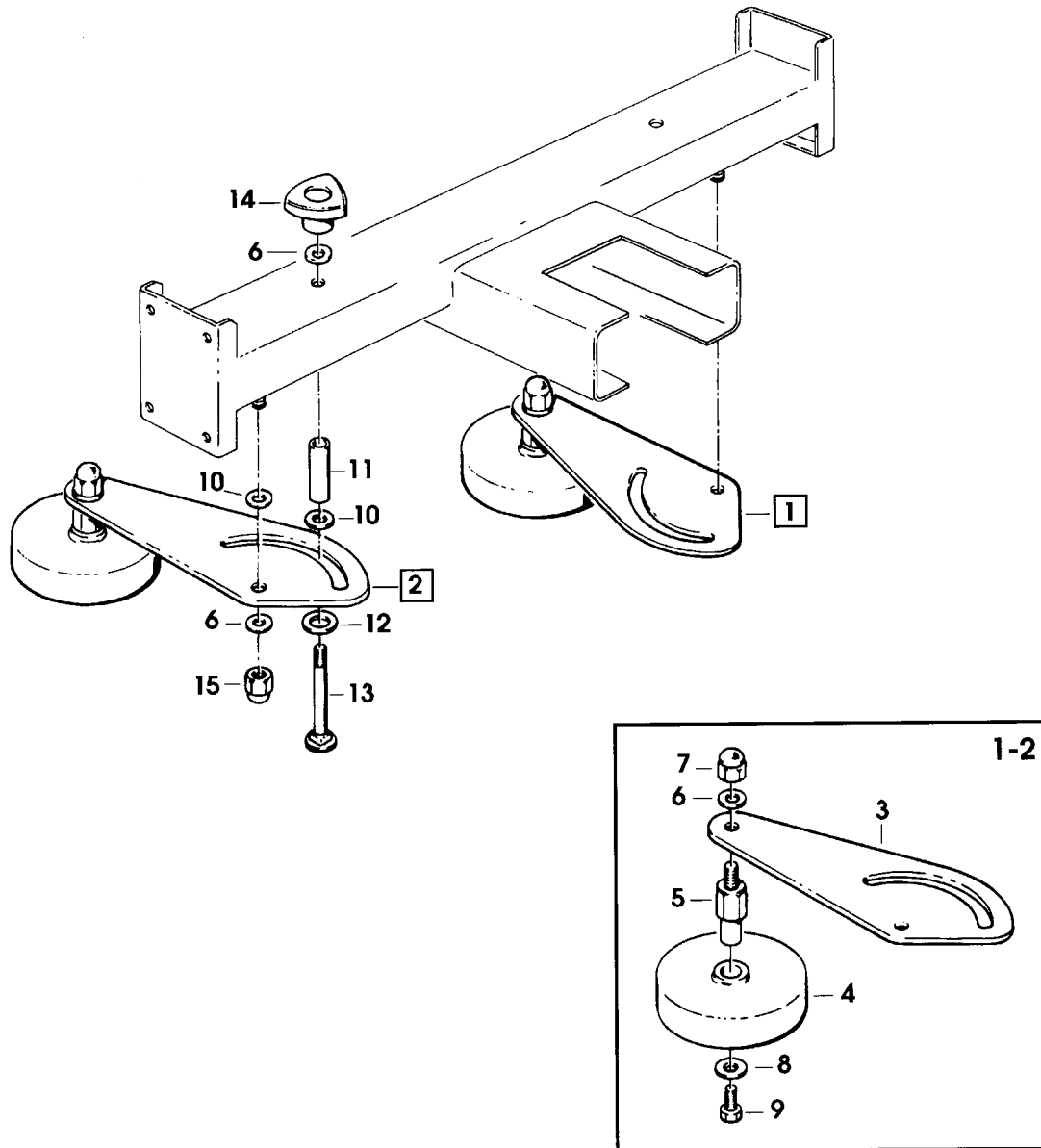

Figure 2798

Figure 2798

Ref. No.	3M Part No.	Description
2798-1	78-8070-1557-9	Compression Roller Assembly – Right
2798-2	78-8070-1558-7	Compression Roller Assembly – Left
2798-3	78-8070-1559-5	Support – Compression Roller
2798-4	78-8054-8648-3	Pressure Roller
2798-5	78-8070-1560-3	Stud – Roller Mounting
2798-6	78-8052-6566-3	Washer – Friction
2798-7	78-8070-1561-1	Nut – M10
2798-8	26-1004-5507-5	Washer – M8
2798-9	26-1003-5841-0	Screw – M8 x 16
2798-10	78-8017-9074-8	Washer – 15 mm, Nylon
2798-11	78-8070-1562-9	Tube – Roller Support
2798-12	12-7991-1752-3	Washer – M14, Plain
2798-13	78-8070-1563-7	Screw – M10 x 80
2798-14	78-8070-1549-6	Knob – VTR-B-M10
2798-15	26-1003-6918-5	Nut – Plastic Insert M10 Hex Flange

200a Adjustable Case Sealer

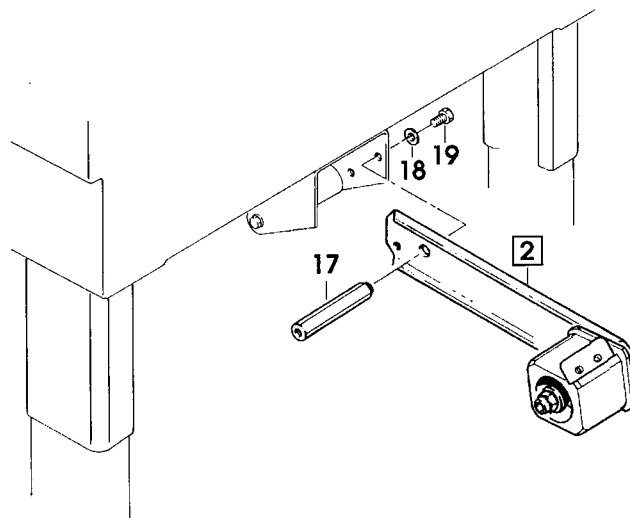
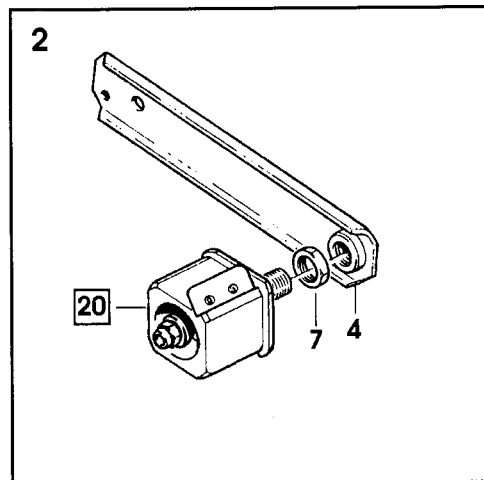
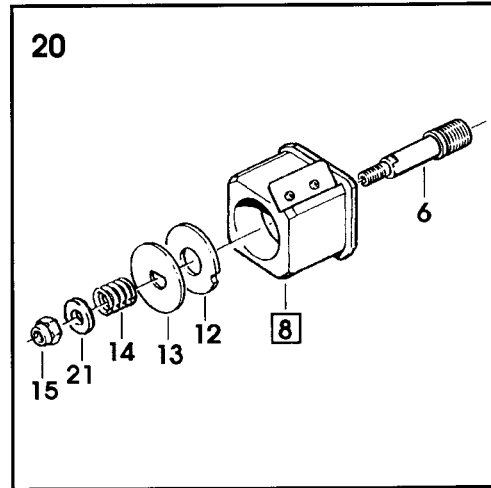
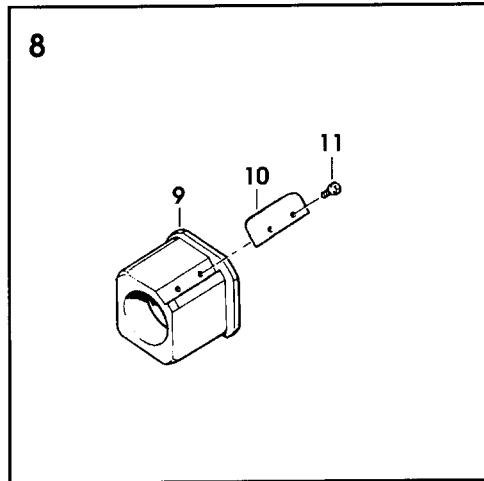
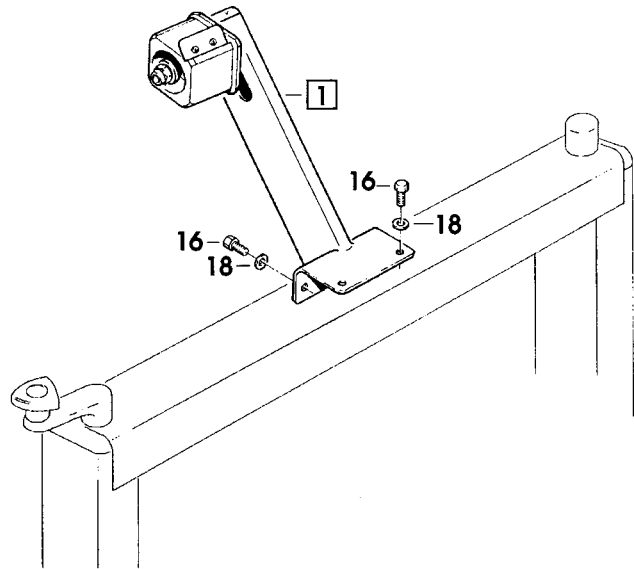
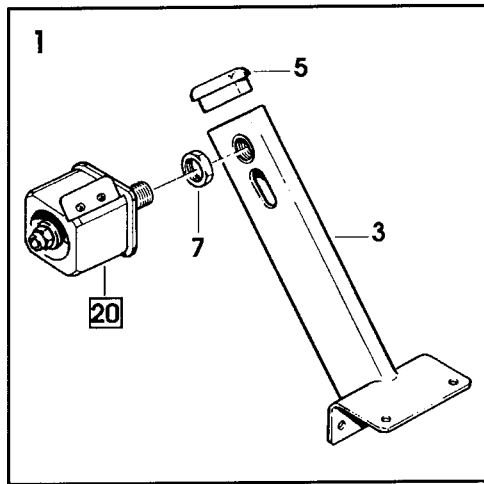

Figure 2799

Figure 2799

Ref. No.	3M Part No.	Description
2799-1	78-8070-1564-5	Tape Drum Bracket Assembly
2799-2	78-8070-1565-2	Tape Drum Bracket Assembly
2799-3	78-8070-1566-0	Bracket – Tape Drum
2799-4	78-8070-1395-4	Bracket – Bushing Assembly
2799-5	78-8070-1568-6	Cap – Bracket
2799-6	78-8076-4519-3	Shaft – Tape Drum 2 Inch
2799-7	78-8017-9169-6	Nut – M18 x 1
2799-8	78-8070-1569-4	Tape Drum Assembly
2799-9	78-8052-6749-5	Tape Drum Assembly
2799-10	78-8052-6268-6	Leaf Spring
2799-11	26-1002-5753-9	Screw – Self Tapping
2799-12	78-8060-8172-1	Washer – Friction
2799-13	78-8052-6271-0	Washer – Tape Drum
2799-14	78-8100-1048-4	Spring – Core Holder
2799-15	78-8017-9077-1	Nut – Self-Locking, M10 x 1
2799-16	78-8032-0375-7	Screw – Hex Hd M6 x 16
2799-17	78-8070-1215-4	Spacer – Stud
2799-18	26-1000-0010-3	Washer – Flat M6
2799-19	78-8010-7169-3	Screw – Hex Hd M6 x 12, Metric
2799-20	78-8060-8474-1	Tape Drum Assembly – 2 Inch Head
2799-21	26-1004-5510-9	Washer – Plain, M10

200a Adjustable Case Sealer

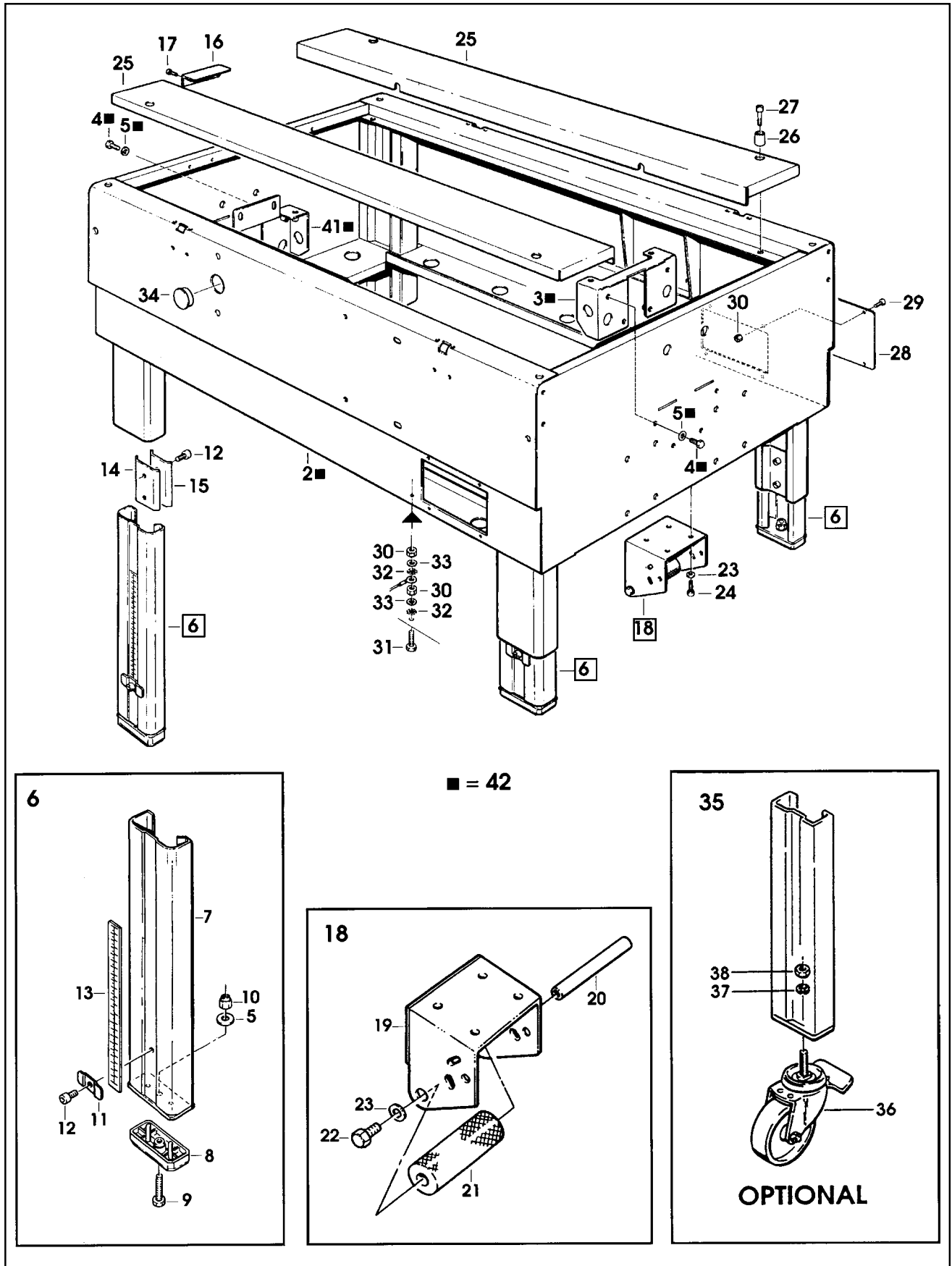

Figure 3430

Figure 3430

Ref. No.	3M Part No.	Description
3430-2	78-8091-0306-8	Bed Conveyor
3430-3	78-8091-0307-6	Support – Drive
3430-4	26-1003-5842-8	Screw – Hex Hd, M8 x 20
3430-5	78-8017-9318-9	Washer – Plain, 8 mm
3430-6	78-8076-5381-7	Leg Assembly – Inner W/Stop
3430-7	78-8076-5382-5	Leg – Inner
3430-8	78-8060-8480-8	Pad – Foot
3430-9	78-8055-0867-4	Screw – Hex Hd, M8 x 30
3430-10	78-8017-9313-0	Nut – Self Locking, M8
3430-11	78-8076-5383-3	Stop – Leg
3430-12	26-1003-7963-0	Screw – Soc Hd, M8 x 16
3430-13	78-8060-8481-6	Label – Height
3430-14	78-8052-6677-8	Clamp – Inner
3430-15	78-8052-6676-0	Clamp – Outer
3430-16	78-8060-8482-4	Plate – Protection
3430-17	26-1003-7948-1	Screw – Soc Hd M5 x 10
3430-18	78-8076-5392-4	Support – Tape Drum
3430-19	78-8060-8483-2	Support – Outboard Roll
3430-20	78-8060-8484-0	Shaft – Roller
3430-21	78-8060-8485-7	Roller
3430-22	78-8032-0375-7	Screw – Hex Hd, M6 x 16
3430-23	26-1000-0010-3	Washer – Flat, M6
3430-24	26-1003-7957-2	Screw – Soc Hd, M6 x 16
3430-25	78-8070-1579-3	Plane – Conveyor Bed
3430-26	78-8060-8486-5	Bushing
3430-27	78-8010-7211-3	Screw – Soc Hd M6 x 25
3430-28	78-8060-8487-3	Cover – Switch
3430-29	78-8060-8087-1	Screw – M5 x 10
3430-30	78-8010-7417-6	Nut – Hex, M5
3430-31	78-8060-8488-1	Screw – Hex Hd, M5 x 20
3430-32	78-8046-8217-3	Washer – Special
3430-33	78-8005-5741-1	Washer – Plain, M5
3430-34	78-8076-4701-7	Cap – /28
3430-35	78-8098-9076-3	Caster Assembly
3430-36	26-1009-9096-4	Caster – Dual Locking
3430-37	26-1009-9094-9	Washer – Spring, Helical, M12
3430-38	26-1009-9095-6	Nut – M12
3430-41	78-8094-6013-8	Support – Drive
3430-42	78-8094-6014-6	Bed – Conveyor, W/Support

200a Adjustable Case Sealer

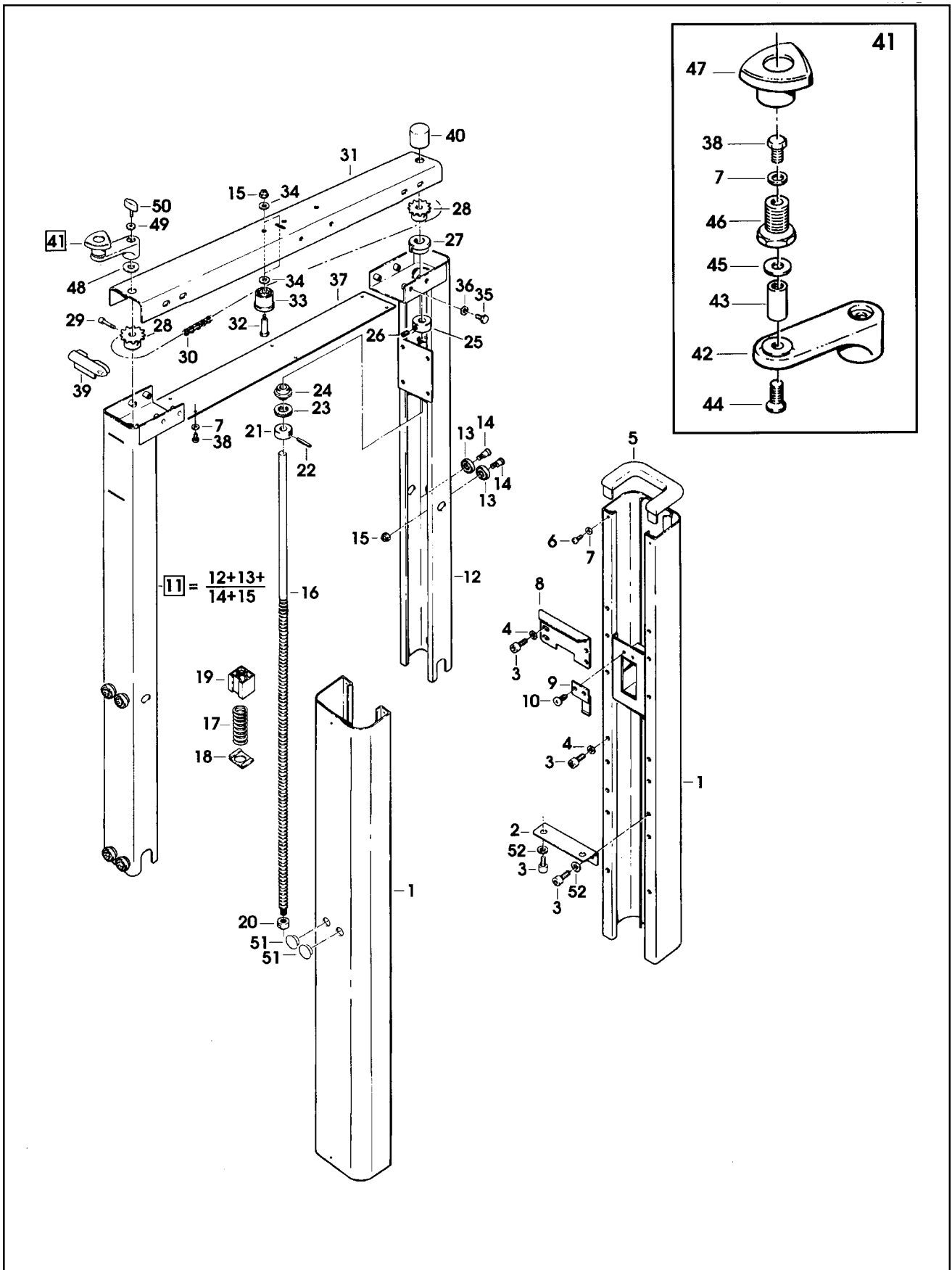

Figure 3431

Figure 3431

Ref. No.	3M Part No.	Description
3431-1	78-8060-8489-9	Column – Outer
3431-2	78-8060-8490-7	Plate – Column Mounting
3431-3	26-1003-7964-8	Screw – Soc Hd Hex Soc Dr, M8 x 20
3431-4	78-8017-9318-9	Washer – Plain, 8 mm
3431-5	78-8060-8491-5	Cap – Column
3431-6	26-1002-4955-1	Screw – Self Tap, 8P x 13
3431-7	78-8005-5740-3	Washer – Plain, 4 mm
3431-8	78-8060-8492-3	Stop – Height
3431-9	78-8076-5482-3	Plate – Nut Stop
3431-10	78-8060-8087-1	Screw – M5 x 10
3431-11	78-8060-8494-9	Column Assembly – Inner
3431-12	78-8060-8495-6	Column – Inner
3431-13	78-8054-8617-8	Bearing – Special
3431-14	78-8054-8589-9	Screw – Special
3431-15	26-1003-6916-9	Nut – Locking M6, Plastic Insert
3431-16	78-8060-8496-4	Lead Screw
3431-17	78-8054-8969-3	Spring
3431-18	78-8054-8970-1	Bed Plate – Spring
3431-19	78-8054-8571-7	Nut – Plastic
3431-20	78-8054-8968-5	Nut – Special
3431-21	78-8054-8585-7	Collar
3431-22	78-8054-8586-5	Pin
3431-23	78-8054-8584-0	Spacer
3431-24	78-8054-8583-2	Bushing
3431-25	78-8060-8497-2	Bushing – Lead Screw
3431-26	78-8059-5617-0	Screw – Set, M6 x 8
3431-27	78-8060-8498-0	Bushing – Inner Column
3431-28	78-8060-8499-8	Sprocket – 3/8 inch
3431-29	26-1003-7946-5	Screw – Soc Hd, M4 x 25
3431-30	78-8070-1501-7	Chain – 3/8 inch, 156 Links
3431-31	78-8113-6755-2	Housing – Chain, W/English Language Label
3431-32	78-8060-7878-4	Screw – Idler
3431-33	78-8070-1503-3	Roller – Chain Tensioning
3431-34	78-8042-2919-9	Washer – M6
3431-35	26-1003-5829-5	Screw – Hex Hd, M6 x 12
3431-36	26-1000-0010-3	Washer – Flat, M6
3431-37	78-8070-1504-1	Cover
3431-38	78-8010-7157-8	Screw – Hex Hd, M4 x 10
3431-39	78-8070-1505-8	Cap – Inner Column
3431-40	78-8070-1506-6	Cover – Screw
3431-41	78-8076-4807-2	Crank Assembly
3431-42	78-8076-5422-9	Crank
3431-43	78-8070-1509-0	Shaft – Crank
3431-44	26-1005-5316-8	Screw – Flat Hd, Hex Dr, M5 x 16
3431-45	78-8070-1510-8	Washer – Nylon, 7 x 15 x 1
3431-46	78-8070-1511-6	Bushing
3431-47	78-8070-1512-4	Knob – VTR-B-M12
3431-48	78-8076-4800-7	Washer – Crank
3431-49	78-8076-4809-8	Washer – Crank
3431-50	78-8076-4821-3	Key – Stop
3431-51	78-8054-8821-6	Cap – End
3431-52	26-1004-5507-5	Washer – M8

200a Adjustable Case Sealer

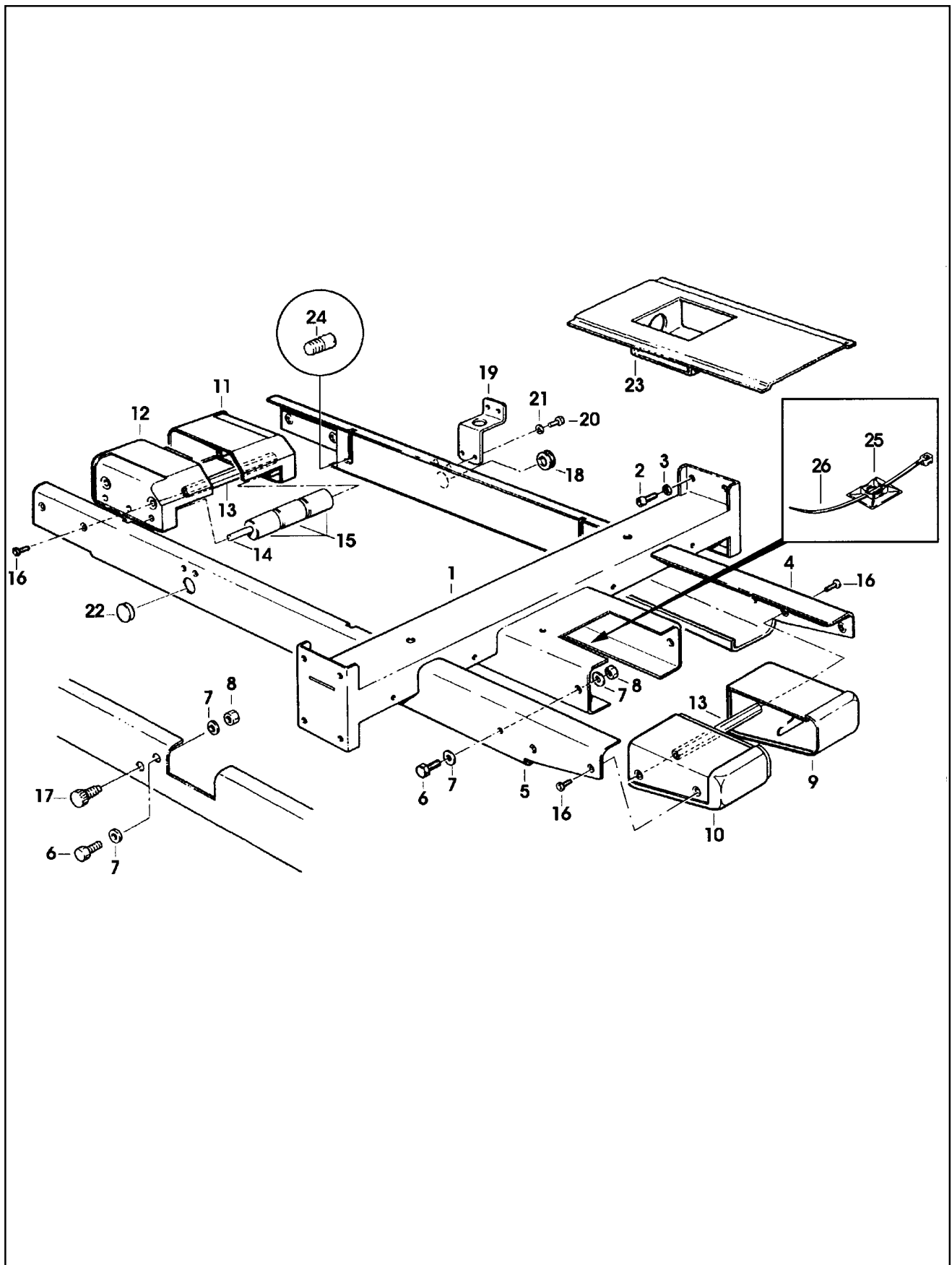

Figure 5592

Figure 5592

Ref. No.	3M Part No.	Description
5592-1	78-8091-0508-9	Bar – Supporting
5592-2	26-1003-7957-2	Screw – Soc Hd Hex Hd, M6 x 16
5592-3	78-8100-1042-7	Washer – /15 x 6.35 x 2
5592-4	78-8113-6756-0	Side Plate – Right, W/English Language Label
5592-5	78-8113-6757-8	Side Plate – Left, W/English Language Label
5592-6	26-1003-5842-8	Screw – Hex Hd, M8 x 20
5592-7	78-8017-9318-9	Washer – Plain, 8 mm
5592-8	26-1000-1347-8	Nut – Hex, M8
5592-9	78-8070-1574-4	Slide – Front, Right
5592-10	78-8070-1575-1	Slide – Front, Left
5592-11	78-8070-1576-9	Slide – Rear, Right
5592-12	78-8070-1577-7	Slide – Rear, Left
5592-13	78-8070-1553-8	Spacer
5592-14	78-8070-1554-6	Stud
5592-15	78-8060-7693-7	Roller – 32 x 38
5592-16	26-1005-5316-8	Screw – Flat Hd Hex Dr, M5 x 16
5592-17	78-8070-1555-3	Block – Upper Head
5592-18	78-8060-7758-8	Fairlead – /20
5592-19	78-8054-8955-2	Clamp – Bracket
5592-20	26-1003-5820-4	Screw – Hex Hd, M5 x 12
5592-21	78-8005-5741-1	Washer – Flat, M5
5592-22	78-8076-4517-7	End Cap – /22 x 1
5592-23	78-8113-6758-6	Cover – Upper, W/English Language Labels
5592-24	78-8076-4500-3	Stud – Mounting
5592-25	78-8070-1318-6	Label – Box Centering
5592-26	78-8100-1234-0	Bezel

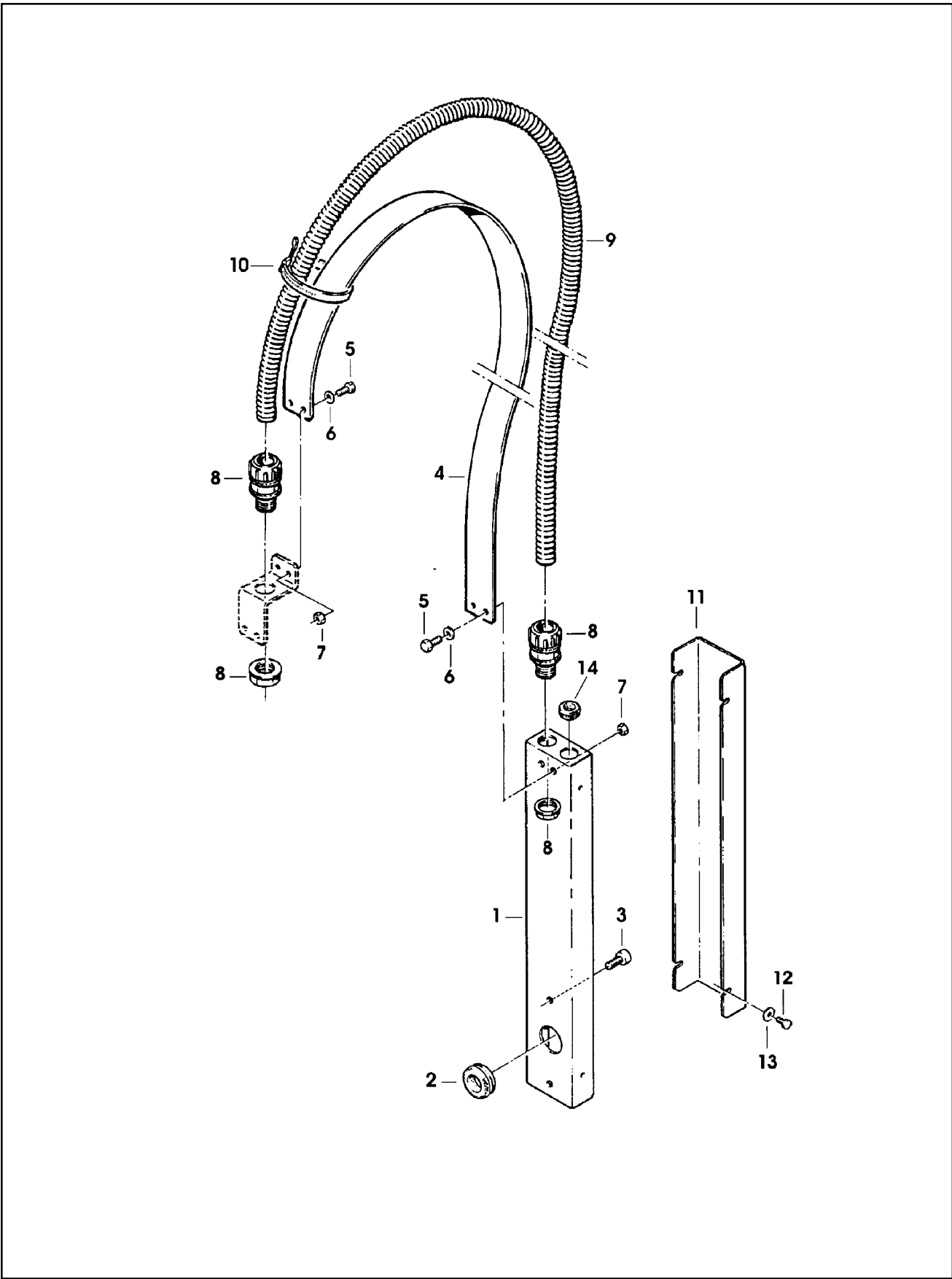

Figure 5593

Figure 5593

Ref. No.	3M Part No.	Description
5593-1	78-8091-0660-8	Housing – Wire
5593-2	78-8076-4702-5	Grommet – /28
5593-3	26-1003-7963-0	Screw – Soc Hd, M8 x 16
5593-4	78-8076-4636-5	Strap – Wire
5593-5	78-8010-7163-6	Screw - Hex Hd, M5 x10
5593-6	78-8005-5741-1	Washer – Flat, M5
5593-7	78-8010-7417-6	Nut – Hex, M5
5593-8	78-8060-7631-7	Connector – 3/8 Inch
5593-9	78-8060-8028-5	Sleeving – /12, 0,93 M.
5593-10	78-8060-8029-3	Clamp – 140 x 3, 5
5593-11	78-8076-4641-5	Cover
5593-12	78-8010-7157-8	Screw – Hex Hd, M4 x 10
5594-13	78-8017-9018-5	Washer – Plain, M4 SPEC.
5594-14	78-8060-7758-8	Fairlead – /20

200a Adjustable Case Sealer

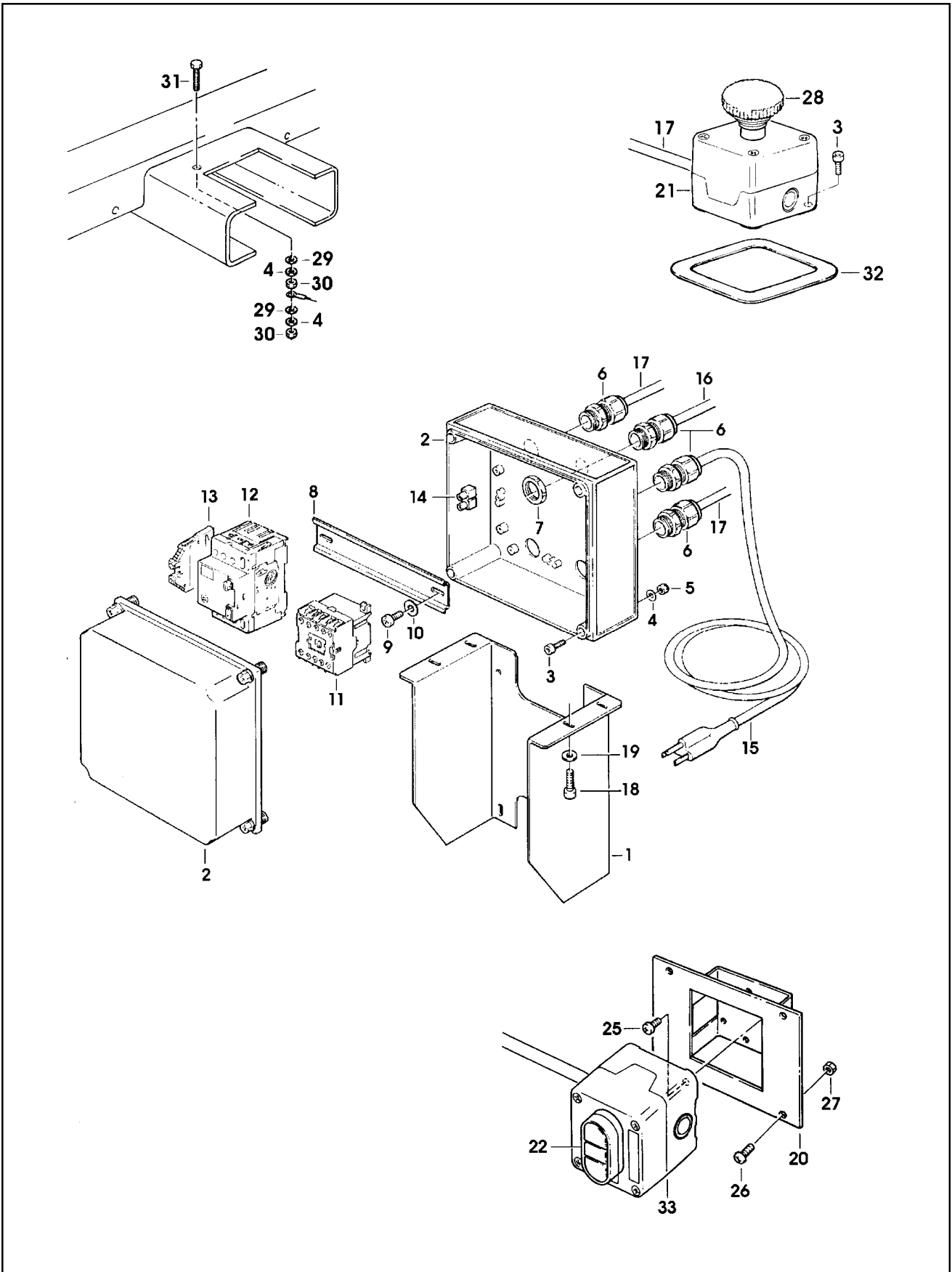
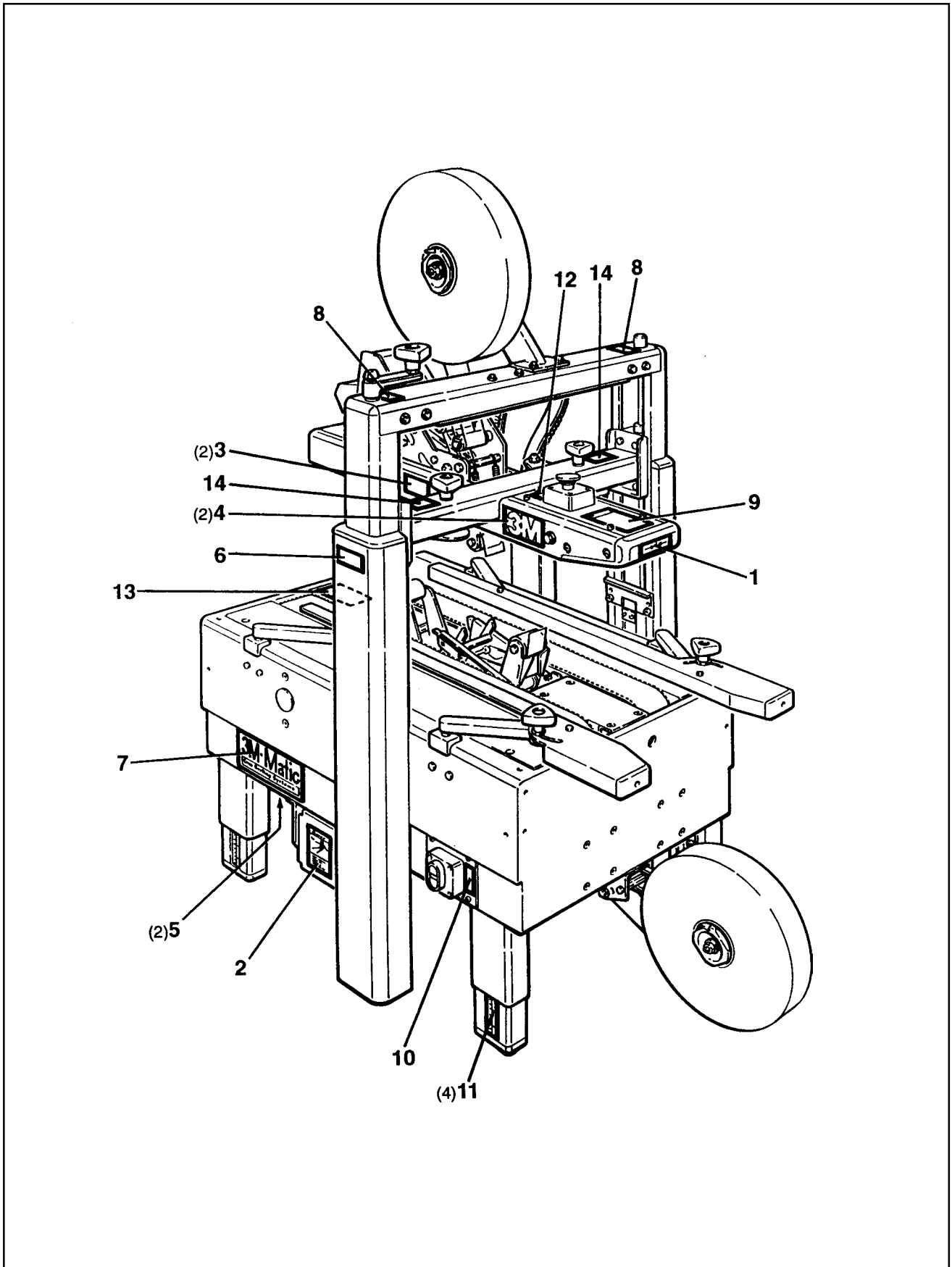

Figure 5594

Figure 5594

Ref. No.	3M Part No.	Description
5594-1	78-8094-6379-3	Support – Box
5594-2	78-8113-6759-4	Enclosure – W/English Language Label
5594-3	78-8094-6381-9	Screw – Soc Hd, M4 x 15
5594-4	78-8005-5740-3	Washer – Plain, 4 mm
5594-5	26-1003-6914-4	Nut – Plastic Insert, M4
5594-6	78-8076-4715-7	Cord Grip
5594-7	78-8076-5211-6	Set Nut – GMP13.5
5594-8	78-8094-6382-7	Guide – Mounting
5594-9	78-8028-8208-0	Screw – 6P X 9,5
5594-10	78-8017-9018-5	Washer – Plain, M4, SPEC
5594-11	78-8094-6383-5	Contactor – Sprecher and Shuh CA4-5-10, 110V, 60Hz
5594-12	78-8076-5378-3	Circuit Breaker – KTA-3-25
5594-13	78-8094-6384-3	Ground Clamp – VGPE 4/6
5594-14	78-8076-4882-5	Terminal Board
5594-15	78-8028-7909-4	Power Cord W/Plug
5594-16	78-8100-1038-5	Cable – 4 x 20 AWG, MT .5
5594-17	78-8060-8053-3	Wire – 3-Pole, 5 Meters Length
5594-18	26-1003-7957-2	Screw – Soc Hd Hex, M6 x 16
5594-19	26-1000-0010-3	Washer – Flat, M6
5594-20	78-8113-6887-3	Support – On/Off Switch, W/English Language Label
5594-21	78-8076-5194-4	Box – E-Stop, Yellow, Allen Bradley 800E-1PY
5594-22	78-8094-6386-8	Switch – On/Off
5594-25	78-8017-9257-9	Screw – M4 x 10
5594-26	78-8060-8087-1	Screw – M5 x 10
5594-27	78-8010-7417-6	Nut – Hex, M5
5594-28	26-1014-5845-8	E-Stop – Allen Bradley MTS-44-3LX01
5594-29	78-8076-4716-5	Star Washer – M4
5594-30	78-8010-7416-8	Nut – Hex, M4
5594-31	78-8091-0538-6	Screw – Hex Hd, M4 x 20
5594-32	78-8100-1234-0	Collar
5594-33	78-8114-4896-4	Box – On/Off, Grey

200a Adjustable Case Sealer



Safety and Information Labels

A label kit, part number 78-8113-6714-9, is available as a stock item. It contains all the safety and information labels used on the case sealer, or labels can be ordered separately from the following list.

Ref. No.	3M Part No.	Description	Qty.
1	78-8070-1318-6	Label – Box Centering	1
2	78-8070-1329-3	Label – Warning, Hazardous Voltage	1
3	78-8070-1336-8	Label – Warning, Sharp Knife	2
4	78-8070-1339-2	Information – 3M Logo	2
5	78-8069-3852-6	Label – Ground	2
6	78-8068-3859-1	Label – Service and Spares	1
7	78-8062-4266-1	Label – Product	1
8	78-8070-1628-8	Label – Up and Down/Lock	2
9	78-8070-1366-5	Label – Safety Instructions	1
10	78-8113-6775-0	Label, Electrical, On/Off	1
11	78-8060-8481-6	Label – Leg	4
12	78-8095-1141-9	Label – Stop	1
13	78-8113-6717-2	Label – Caution, Pinch Point	1
14	78-8113-6912-9	Label – Caution, Pinch Point	2