

SFS81 Series

Servo Finishing Stand

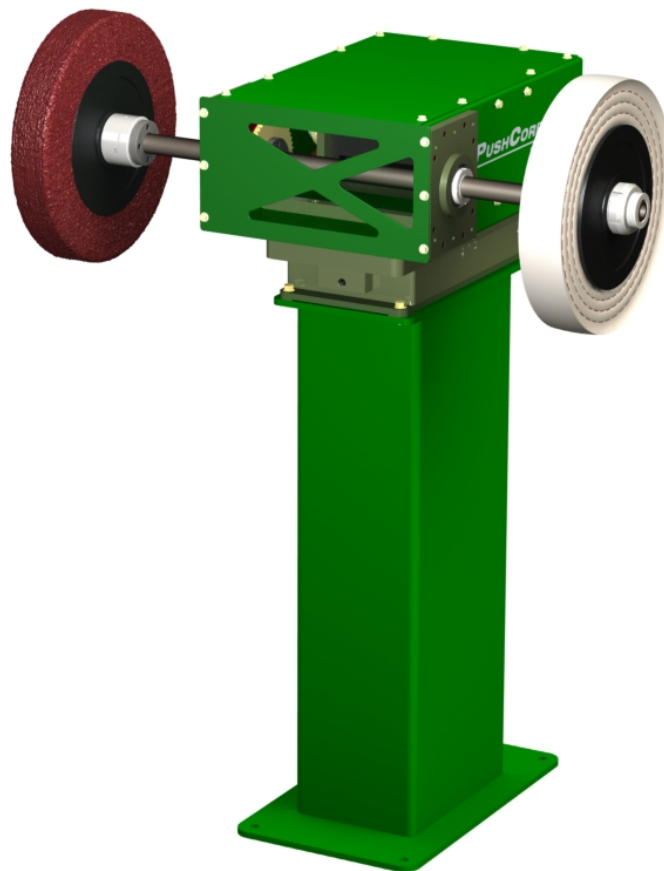

PUSHCORP, INC.

Dallas, Texas

May, 2012

**NEVER OPERATE THE
SFS81 MANUALLY**

**NEVER OPERATE THE SFS81 WITH
PERSONEL IN THE WORKCELL**

DO NOT USE LUBRICATED AIR.

**This device requires a dry, non-lubricated
100 psi (6.9 bar) maximum air supply
filtered to 5 μm and a 0.3 micron oil mist
separator.**

**Non-compliance with these requirements
will void the manufacturer's warranty.**

(See Section 3.4)

**All fasteners, mounting holes and pipe
threads on this tool are METRIC.**

Table of Contents

1.0 LIMITED WARRANTY.....	2
2.0 GENERAL OVERVIEW.....	4
3.0 INSTALLATION.....	5
3.1 Mounting the SFS81.....	5
3.2 Electrical Connections.....	6
3.3 Electrical Control Box.....	8
3.4 Pneumatic Connections.....	8
4.0 OPERATION.....	10
4.1 Media Mounting.....	10
4.2 Achieving Desired Force.....	11
4.3 Achieving Desired Media Speed.....	11
4.4 Drive Belt Replacement.....	11
4.5 Media Position Feedback.....	11
5.0 TECHNICAL SPECIFICATIONS.....	13

1.0 Limited Warranty

Duration:

One year from date of delivery to the original purchaser.

Who gives this warranty (warrantor):

PushCorp, Inc.

Telephone: (972) 840-0208

Corporate Address:

P. O. Box 181915

Dallas, Texas 75218

Shipping Address:

3001 W. Kingsley Rd.

Garland, Texas 75041

Who receives this warranty (purchaser):

The original purchaser (other than for purposes of resale) of the *PushCorp, Inc.* product

What products are covered by this warranty:

Any *PushCorp, Inc.* Adjustable Force Device or Adjustable Force Device accessory supplied or manufactured by the Warrantor.

What is covered under this warranty:

Defects in material and/or workmanship which occur within the duration of the warranty period.

What is NOT covered in this warranty:

- A. IMPLIED WARRANTIES, INCLUDING THOSE OF MERCHANTABILITY AND FITNESS FOR A PARTICULAR PURPOSE ARE LIMITED TO ONE YEAR FROM THE DATE OF ORIGINAL PURCHASE. Some states do not allow limitations on how long an implied warranty lasts, so the above limitations may not apply to you.
- B. ANY INCIDENTAL, INDIRECT, OR CONSEQUENTIAL LOSS, DAMAGE or EXPENSE THAT MAY RESULT FROM ANY DEFECT, FAILURE, MALFUNCTION OF THE *PUSHCORP, INC.* PRODUCT. Some states do not allow the exclusion or limitation of incidental or consequential damages so the above limitation or exclusion may not apply to you.
- C. Any failure that results from an accident, purchaser's abuse, neglect, unauthorized repair or failure to operate the products in accordance with the instructions provided in the owner's manual(s) supplied with the product.

Responsibilities of the Warrantor under this warranty:

Repair or replace, at Warrantor's option, products or components which have failed within the duration of the warranty period.

Responsibilities of the purchaser under this warranty:

- A. Deliver or ship the *PushCorp, Inc.* product or component to PushCorp, Inc. Service Center, Dallas, TX. Freight and insurance costs, if any, must be borne by the purchaser.
- B. Use reasonable care in the operation and maintenance of the product as described in the owner's manual(s).

When warrantor will perform repair or replacement under this warranty:

Repair or replacement will be scheduled and serviced according to the normal work flow at the service center, and depending on the availability of replacement parts. Purchasers requiring quicker repair may receive such with payment of a *PushCorp, Inc.* predetermined expediting fee.

This Limited Warranty gives you specific legal rights and you may also have other rights which vary from state to state.

2.0 General Overview

The PushCorp SFS81 Series Servo Finishing Stand combines passive compliant force control and closed-loop servo motor speed control technology. The SFS81 has been designed from the ground up as a Finishing Stand for robotic applications with many new and unique features.

Accurate force and speed control allows you to achieve unprecedented levels of quality and consistency. The SFS81 enables maximum flexibility for any part-in-hand grinding, sanding, buffing or polishing application. Linear compliance with 1.6 inches (40 mm) of travel and excellent access allow a robot to easily manipulate parts over the Media. An important feature of the SFS81 Finishing Stand is the high torque servo motor and belt drive. The belt drive system provides a 2:1 increase in torque at the Media for heavy material removal.

The force control technology in the SFS81 is based on the *PushCorp* Passive AFD80 Series Force Devices. This technology has proven itself in thousands of hours of production robotic applications. The standard regulator supplied with the SFS81 allows the force to be varied from 2 to 100 lbs. (8 to 445 N). This regulator has a coarse adjustment and must be manually set to the desired force output. If the force must vary during the finishing process, then an electrically controlled proportional regulator is required. Very accurate force output requires a precision regulator that operates in a narrow pressure range.

The electrical control box is mounted remotely from the Finish Stand outside the robot enclosure to protect it from dust and vibration. Electrical interface cables are ordered separately and can be made to any length up to 30 meters as required by the customer's installation.

In most any finishing process, consistency is of paramount importance. For this reason the SFS81 is powered by a high torque servo motor with adjustable speed control that can be varied at any time during the finishing process. The SFS81 has a 6 horsepower (4.5 kW) motor that supplies 16 lb•ft (22 N•m) of continuous torque and a maximum rotational speed of 2000 RPM at the media mounting shaft. With dual 30mm shafts the user can mix & match their Media allowing multiple finishing operations at the same piece of equipment. This flexibility allows the SFS81 to perform a wide variety of finishing applications.

3.0 Installation

3.1 Mounting the SFS81

The SFS81 Servo Finishing Stand is secured by four (4) fasteners passing through mounting holes located in the Base Plate. The Base Plate mounting hole locations are shown in Figure 1. The SFS81 must be securely mounted to keep the unit from moving during operation, and must be mounted level to achieve the desired force output. A spirit level can be placed on the top of the Finishing Stand and shims can be inserted under the Base Plate as required.

WARNING: Do NOT operate the unit without first mounting it securely.

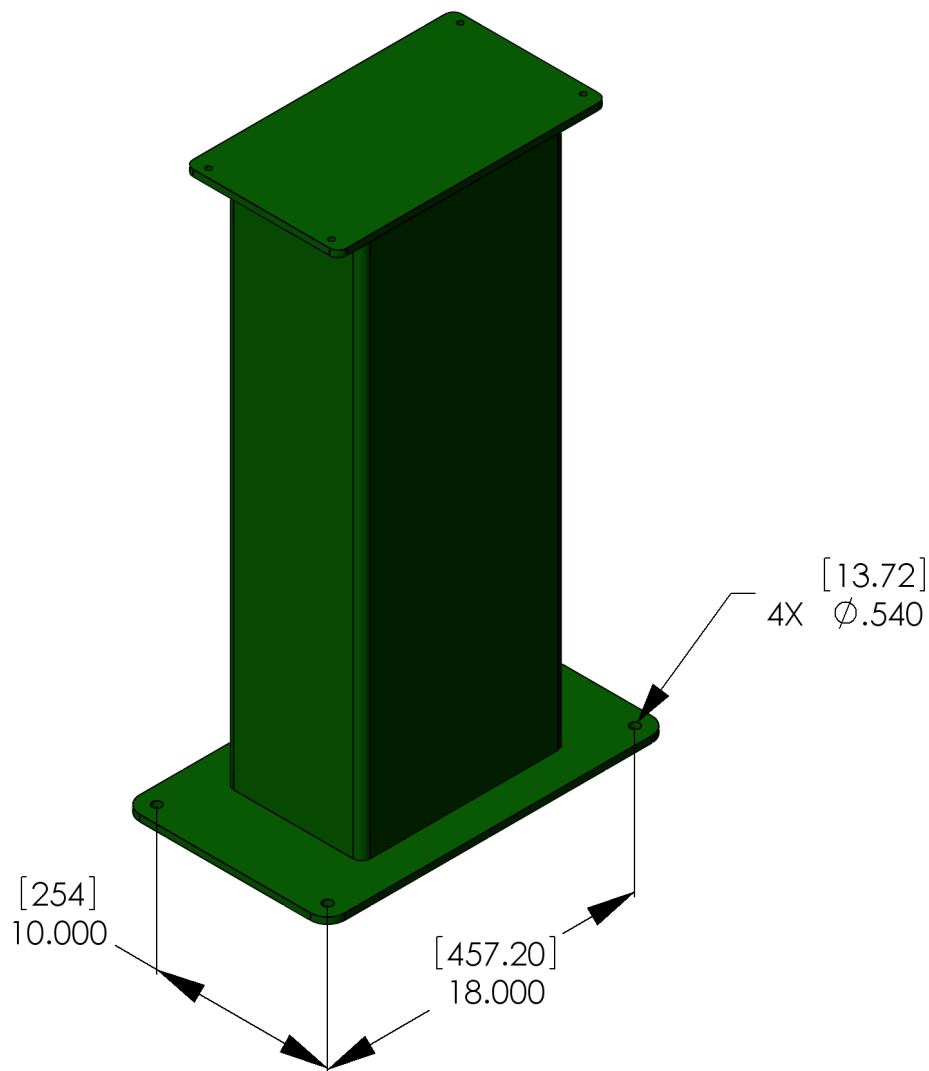

Figure 1. SFS81 Base Plate mounting holes

The SFS81 attaches with four (4) fasteners, 1/2 inch (12 mm) in diameter. These fasteners are to be provided by the installer.

3.2 Electrical Connections

The SFS81 requires 208 - 480 VAC, 3-Phase, 50-60 Hz. power to operate. This should be supplied via conduit connection to the Control Box. The electrical connections are made to the User Interface Blocks as shown in Figure 2.

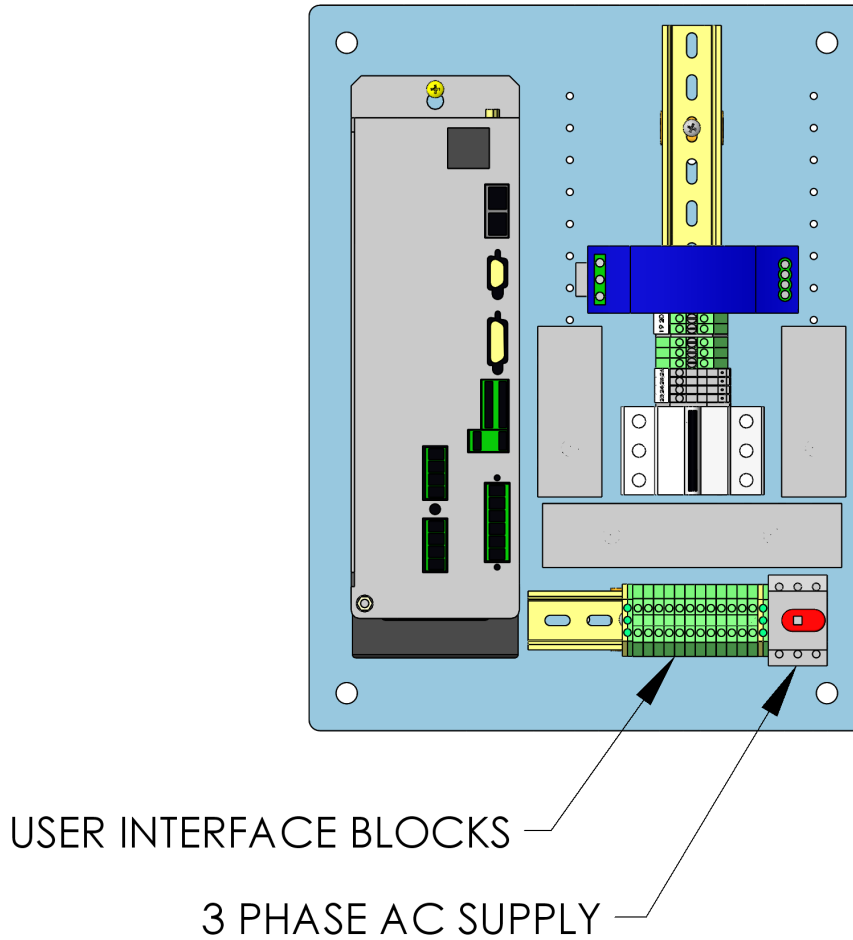

Figure 2. User Interface terminal blocks

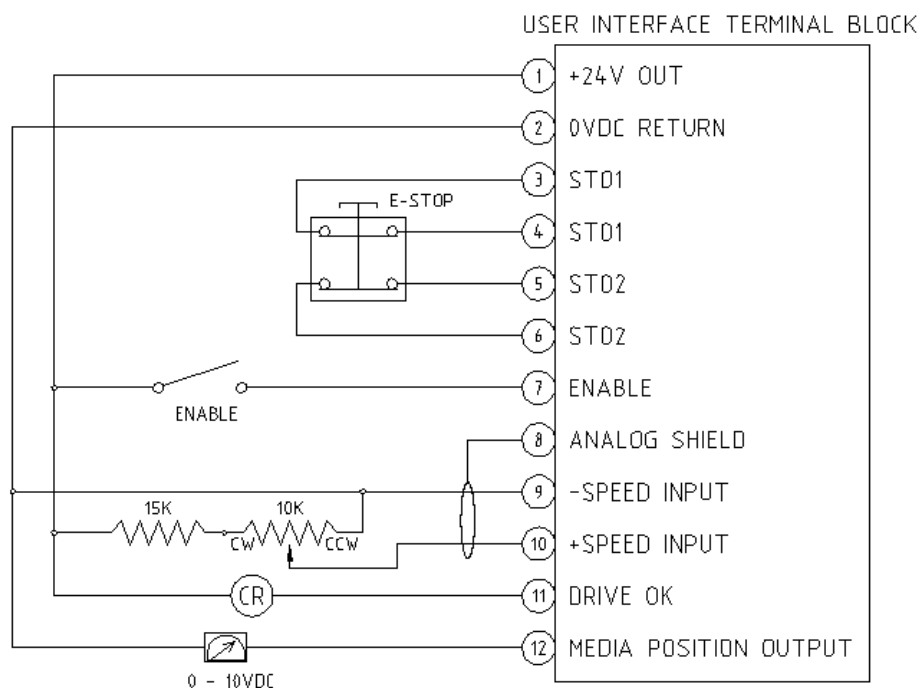

Figure 3. SFS81 Typical User Interface Schematic

The circuit diagram in Figure 3 shows the SFS81 wired for stand-alone panel operation. **All digital I/O on the SFS81 is designed for 24 VDC control voltages.**

The Mounting Shaft rotational speed is controlled via a 0 - 10VDC analog signal applied to terminals 9 and 10. The analog input is a true floating differential signal connected directly to the servo amplifier. The circuit shown in Figure 2 is an example of how the shaft speed may be controlled with a simple panel mount linear potentiometer. If remote robot teach pendent adjustment is desired, the potentiometer would be replaced with an analog signal from a robot analog output card connected directly to Pins 9 and 10.

WARNING: The differential voltage applied to terminals 9 and 10 should not exceed 10 VDC or damage will occur to the servo amplifier.

Terminal 7, shown in Figure 2 provides the servo amplifier enable signal. Connecting Terminal 7 to +24VDC enables the servo amplifier and applies voltage to the servo motor. Removing voltage from terminal 7 disables the amplifier.

The “DRIVE OK” output on Terminal 11 should be continuously monitored by the End-user control system. This signal should be “ON” during normal operation. An “OFF” condition indicates a drive fault. The cause of the fault will be indicated by a flashing code on the servo drive amplifier.

OPERATION SHOULD CEASE UNTIL THE FAULT CONDITION IS CORRECTED.

The Electrical Control box includes a built-in E-Stop push button switch that, when pressed, immediately removes all electrical power from the motor. If desired, the SBS81 can be connected to an external, dual-channel, E-Stop circuit by connecting to the STO1 and STO2 signal on Terminals 3, 4, 5, and 6 as shown.

It is the responsibility of the System Integrator and/or End-user to follow all applicable electrical codes and OSHA safety standards when wiring the SFS81.

This includes the proper and judicious use of fuses, contactors, cut-off switches, lock-out switches, and Emergency Stop circuits. PushCorp, Inc. assumes no responsibility or liability for the electrical system design and implementation of the SFS81 in the End-user application. Refer to OSHA rules and regulations, as well as the CE Machinery Regulations (IEC 204-1), when designing systems that include motors and drives to ensure that the user is protected.

PushCorp will provide answers to any questions regarding the servo drive system and will be responsible for any warranty issues.

3.3 Electrical Control Box

The SFS81 Electrical Control Box is designed to be wall mounted outside the robot work area in a relatively clean environment. Figure 4 shows the mounting dimensions of the electrical enclosure.

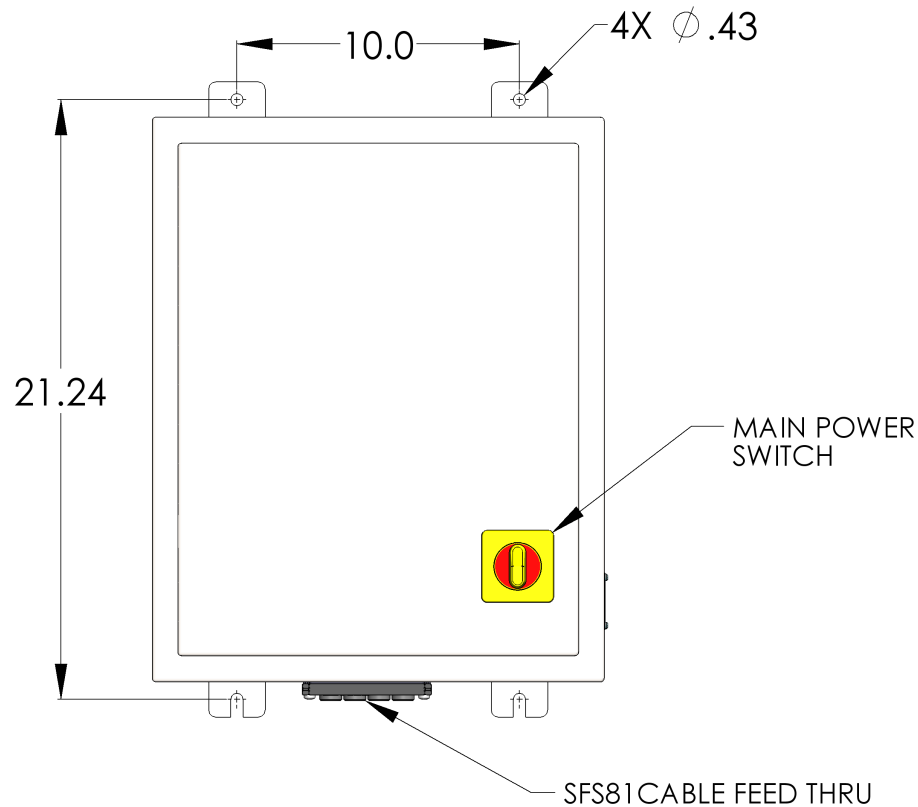

Figure 4. Electrical Control Box Mounting

It is the responsibility of the installer to punch holes in the enclosure for conduit and/or cord grips as required for the electrical supply power wiring and low-voltage control signals.

3.4 Pneumatic Connections

The SFS81 Finishing Stand requires a dry, non-lubricated, 5 micron filtered, 80 to 100 psi (5 - 7 Bar) air supply with a 0.3 micron oil mist separator. Failure to provide supply air to these specifications can degrade performance and will void any warranty repairs concerning pneumatic components. Additionally, a *minimum* 80 psi (5 Bar) air pressure must be maintained for the device to operate within published specifications. Low air pressure will cause inferior force control performance.

The pneumatic supply system should be configured as shown in Figure 5.

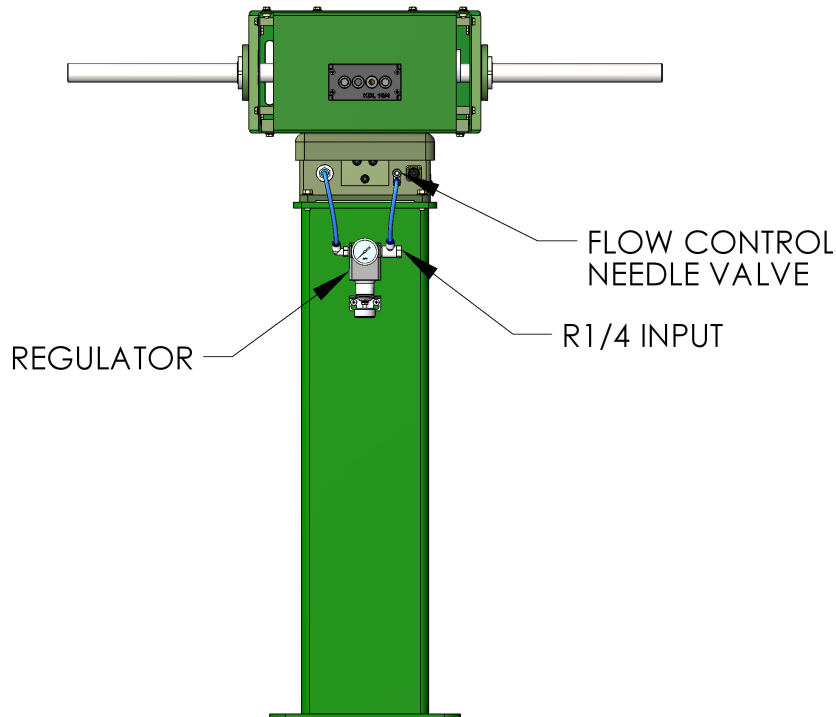

Figure 5. Pneumatic Connections

WARNING: If water condensation is present in your air supply system, an air dryer device is highly recommended. Moisture inside the device will cause premature failure that will not be covered under warranty.

The SFS81 Finishing Stand AFD maintains a positive air pressure to impede the infiltration of contaminate materials. The amount of air entering the AFD is set by adjusting the Flow Control Needle Valve located on the rear of the unit. It is important to provide a continuous compressed air supply to the device at all times if the work environment contains airborne contaminants. If the environment is clean during non-operational periods, the air supply to the device may be shut off.

The SFS81 has one pneumatic input, an R 1/4 (Metric) port located on the SFS81 Regulator (Figure 5). This port supplies all the air needed to operated the Finishing Stand. Before connecting the supply to the air fitting, open the supply valve to blow out any contaminants which may be in the line. Charge the supply line with compressed air and verify that there are no air leaks and that there is a minimum of 80 psi (5 Bar). If a minimum air pressure of 80 PSI cannot be achieved, then an auxiliary air compressor or booster pump must be installed.

4.0 Operation

4.1 Media Mounting

The SFS81 has dual 30mm diameter Mounting Shafts that protrude 10.6 in. (271 mm). The user is responsible for choosing the appropriate means to attach their Media to the Mounting Shafts. One option PushCorp recommends is to use an SKF 30mm Shaft Hub (SKF Part # SHT30, PushCorp P/N PAR02456). These may be purchased directly from SKF or through PushCorp. The hubs securely lock the Media Adapter Arbor to the Output Shaft in a way that keeps the Media concentric to the Mounting Shaft and transmits the required torque. Media adapter assemblies are not supplied with the SFS81.

Figure 6, below, illustrates one method of mounting utilizing the SKF Shaft Hubs.

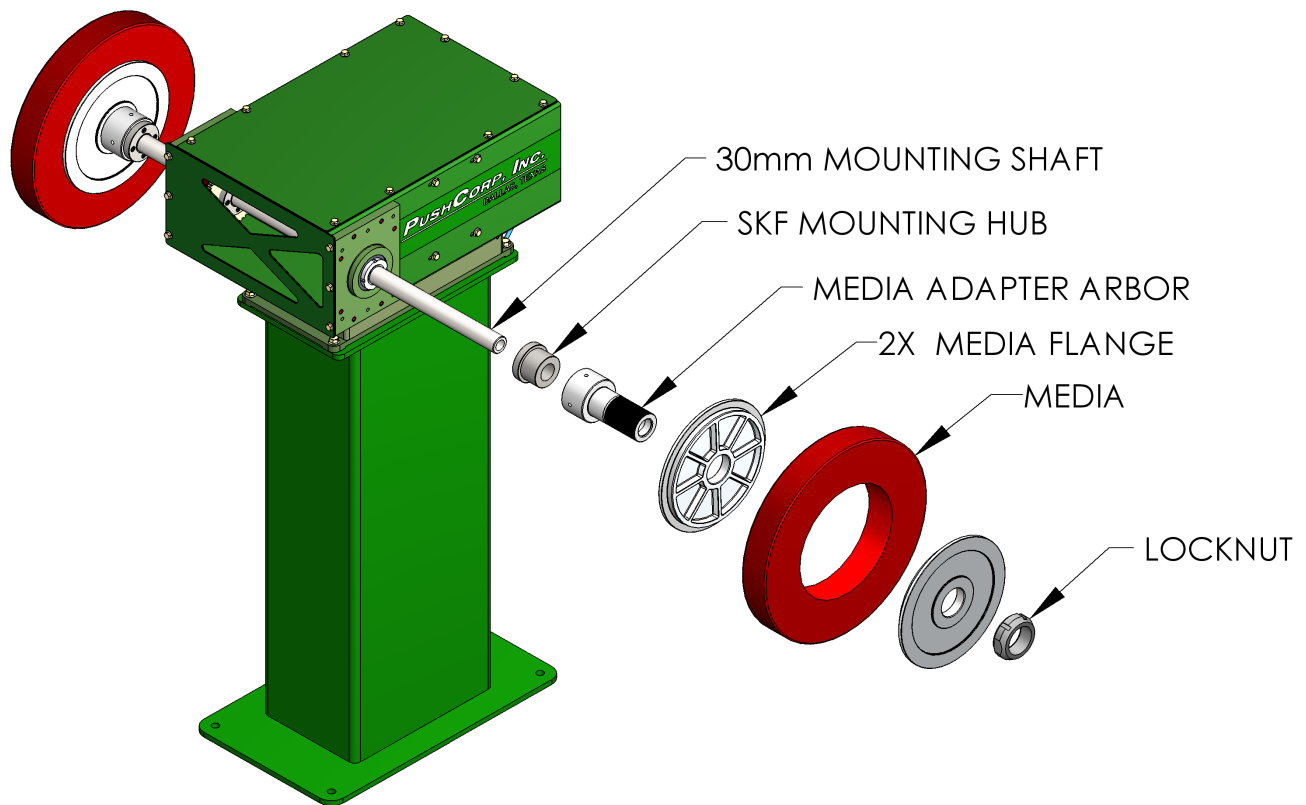

Figure 6. Example of Media mounting

4.2 Achieving Desired Force

The SFS81 uses a modified passive *80 Series* AFD to supply a compliant force from 2 to 100 lbs. (8 to 445 N). The passive force device requires the user to provide regulated air pressure to achieve a desired force output at the Media. Use the following equations to determine the pressure required to achieve the desired output force:

$$F = (1.4 \times P_s) \text{ Applied Force (lbs)}$$

$$F = (89 \times P_s) \text{ Applied Force (N)}$$

Where:

$$P_s = \text{Regulator pressure (PSI or Bar)}$$

PushCorp has included a manual regulator to allow for quick set-up. This manually adjustable pressure regulator may be sufficient, but if remote operation of the force output is needed, then an electrically controlled proportional air regulator will be required. The accuracy of the force output is directly related to the precision and quality of the pressure regulator. A regulator that operates over a limited range (i.e., 0-15 psi) is required for the most precise low force output.

4.3 Achieving Desired Media Speed

The Output Shaft rotational speed is controlled via a 0 - 10VDC analog signal applied to Pins 9 and 10 of the User Interface Connector. The user must scale the command voltage to the servo motor amplifier from 0 to 10 Volts, which commands an Output Shaft rotational speed of 0 to 2000 rpm. The user is responsible for determining the maximum allowable speed for their Media. The SFS81 is factory limited to operate at a maximum Mounting Shaft rotational speed of 2000 rpm. Figure 2 shows a simple circuit using a linear potentiometer to control Media speed, however most installations will require a remote voltage command from a robot or PLC analog output card to vary the rotational speed of the Media.

4.4 Drive Belt Replacement

The SFS81 uses a 2:1 reduction timing belt drive to transfer power from the Servo Motor to the Mounting Shaft. This drive incorporates a high-strength Gates Poly Chain GT2 belt, PushCorp Part No. PAR01889-1. Should this Drive Belt ever require replacement, contact PushCorp for the proper procedure.

4.5 Media Position Feedback

The SFS81 comes equipped with an internal potentiometer that provides a voltage signal based on the linear position of the Media. The voltage signal is at a minimum value when the Media is pushed back against the rubber stops, and a maximum value when the Media is forward against the rubber stops. The total linear compliant stroke is 1.6 in. (40 mm).

The linear position signal must be calibrated for each installation. User calibration is easily accomplished using the following steps.

1. Turn off the supply air to the SFS81
2. Push the Media to the rearward (negative) position.
3. Read the voltage signal on Pin 12 of the User Interface Connector. Record this voltage for future reference. This will be referred to as V_n .
4. Pull the Media to the forward (positive) position.
5. Read the voltage signal on Pin 12 of the User Interface Connector. Record this voltage for future reference. This will be referred to as V_p .
6. The position of the Media can now be determined by measuring the voltage, V_m on Pin 12 of the User Interface Connector, and inserting the value into the following equation:

$$p = 1.6\text{in} \times \left(\frac{V_m - V_n}{V_p - V_n} \right) \text{ English units}$$

$$p = 40\text{mm} \times \left(\frac{V_m - V_n}{V_p - V_n} \right) \text{ Metric units}$$

Where,

p = Media Wheel Position (in,mm)

V_m = Voltage measured on Pin 12 (V)

V_n = Calibrated voltage at rearward position (V)

V_p = Calibrated voltage at forward position (V)

5.0 Technical Specifications

Maximum Applied Force: 100 lbs. (445 N)
Weight: 370 lbs. (168 kg)
Force Scale Factor: 1.4 lbs/psi (890 N/MPa)
Compliant Stroke: 1.6 in. (40 mm)
Supply air: Non-lubricated, Dry, 5µm Filtered, 100 psi (0.7 MPa) Max.
Supply Voltage: 208 - 480 VAC, 3-Phase
Max. Cont. Current: 30 Amps
Max. Peak Current: 60 Amps (2 Seconds)

Specifications subject to change without notice.

Fastener Tightening Torque Specs					
Fastener Size	Torque			Minimum Depth	
	in.-lbs.	ft.-lbs.	N·m	in.	mm
M4 x .7	50	4.2	5.6	0.17	4.3
M5 x .8	85	7.1	9.6	0.21	5.3
M6 x 1	140	11.7	15.8	0.25	6.3
M8 x 1.25	348	29.0	39.3	0.33	8.4
M10 x 1.5	600	50.0	67.8	0.41	10.5