

---

## AF-305 and AF-605 Punch cutter for belts and tapes

---



The AF-xx05 punch cutter range includes models AF-305 and AF-605 which can punch cut belt ends according to flex geometries, thus preparing edges for subsequent hot joining.

The main features are:

- ❑ Reduced dimensions and transportable for field use
  - ❑ Wide range of achievable flex geometries
  - ❑ Only compressed air supply is required for operation
  - ❑ Wide range of punch cut products (tapes, belts, HabaSYNC timing belt)
  - ❑ Easy to use with high quality results
-

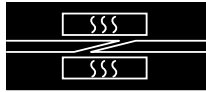

## Contents

<b>1</b>	<b>GENERAL INFORMATION .....</b>	<b>3</b>
1.1	APPLICATION.....	3
1.2	SAFETY INDICATIONS .....	3
1.3	STANDARDS AND ACCESSORIES .....	4
1.3.1	STANDARD MATERIAL.....	4
1.3.2	OPTIONAL ACCESSORIES.....	4
1.4	ACCESSORY/SPARE PART ORDERS.....	5
1.5	WARRANTY .....	5
1.6	TECHNICAL CONSULTING.....	5
<b>2</b>	<b>OPERATING MODE .....</b>	<b>6</b>
2.1	PRELIMINARY OPERATIONS .....	6
2.2	TRANSPORT .....	6
2.3	COMPRESSED AIR CONNECTION .....	7
2.4	FLEX CUTTING HEAD INSTALLATION.....	7
<b>3</b>	<b>PUNCH CUTTING.....</b>	<b>8</b>
3.1	PRELIMINARY OPERATIONS .....	8
3.2	FLEX PUNCH CUTTING OPERATIONS .....	11
<b>4</b>	<b>ASSISTANCE .....</b>	<b>12</b>
4.1	FAULTS.....	12
4.2	KNIFE REPLACEMENT ON THE CUTTING HEAD .....	12
4.3	MAINTENANCE.....	12
4.4	ROUTINE MAINTENANCE .....	13
5.1.1	EXTRAORDINARY MAINTENANCE .....	13
<b>5</b>	<b>TECHNICAL SPECIFICATIONS .....</b>	<b>14</b>
5.1	AF-305 AND AF-605 PUNCH CUTTER TECHNICAL SPECIFICATIONS.....	14
	AF-05 SERIES PUNCH CUTTER PNEUMATIC DIAGRAM .....	15
<b>6</b>	<b>PREFACE .....</b>	<b>17</b>
1.7	MANUFACTURER'S ADDRESS.....	17
1.8	TECHNICAL CONSULTING.....	17
<b>7</b>	<b>REGULATIONS AND GENERAL WARNINGS .....</b>	<b>18</b>
7.1	MANUAL LAYOUT CRITERIA.....	18
7.2	MANUAL USE CRITERIA.....	18
7.3	DIMENSIONS .....	19
<b>8</b>	<b>SPARE PARTS.....</b>	<b>20</b>
8.1	COMPLETE MACHINE GROUP .....	20
	.....	20
8.2	SUPPORT BEAM AND CARRIAGE MOVEMENT GROUP – ID004763.....	22
8.3	SUPPORT BEAM AND CARRIAGE MOVEMENT GROUP – ID004763.....	25
8.4	CARRIAGE MOVEMENT GROUP – PITCH INDEXING SYSTEM DETAIL.....	27
8.5	GROUP – ID004674 FRAME GROUP.....	29
8.6	GROUP – ID004764 – MAIN FRAME.....	31
<b>9</b>	<b>PRODUCT AND PRODUCT USE LIABILITIES.....</b>	<b>33</b>

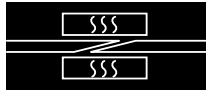

# 1 General information

## 1.1 Application

The AF-xx05 punch cutter series was specifically designed to punch cut Habasit power transmission tapes and transport belts elements according flex geometries using a knife cutting process.

The AF-xx05 punch cutter series was exclusively developed for the applications described hereto. Other or unsuitable applications are prohibited. Habasit shall not be liable for unintended application consequences.

The AF-xx05 punch cutter series was professionally manufactured in accordance with EC safety instructions.

All assembly, maintenance and repair work, as well as the operation of the equipment, is expected to be carried out by qualified personnel or staff under the supervision of responsible specialists and experts.

For space reasons, these instructions for use cannot cover all possible operating, maintenance and repair aspects. The indications provided concern normal machine use by qualified personnel. In the event of doubt or in need of further information, always contact the manufacturer (see chapter 1.4).

## 1.2 Safety indications

This manual includes the terms ATTENTION, CAUTION, NOTE, which indicate hazards or specific information to be kept in mind.

<b>ATTENTION</b>	Serious injury and/or serious material damages may ensue if ignored.
<b>CAUTION</b>	injury and/or material damages may ensue if ignored.
<b>NOTE</b>	Indicates important technical information that may not be known to even expert personnel.

Observe all the machine assembly, operating and maintenance indications as well as technical specifications!

This will prevent personal or property problems and/or damages.

Expert personnel means people authorized to perform the required operations. These people have been sufficiently trained and have acquired experience in their field that lets them recognise and avoid hazards and they are aware of specific safety provisions and regulations.

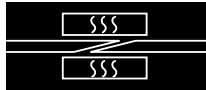

## 1.3 Standards and accessories

### 1.3.1 Standard material

1. The AF-305 or AF-605 comes with a user manual and spare parts manual.

### 1.3.2 Optional accessories

Cutting heads for flexproof geometries, spare knives and cutting pads:

H Code	Item Description	Flex geometry
H080709541	Flex cutting head AF-10/80	10 x 80 mm
H080709542	Flex cutting head AF-20/80	20 x 80 mm
H080709543	Flex cutting head AF-10/50	10 x 50 mm
H080709544	Flex cutting head AF-20/50	20 x 50 mm
H080709545	Flex cutting head AF-10/120	10 x 120 mm
H080709573	Flex cutting head AF-8/30	8 x 30 mm
H08D003641	Flex cutting head AF-16/120-TB	16 x 120 mm
H08D004129	Flex cutting head AF-16/80-TB	16 x 80 mm
H08D006115	Flex cutting head AF-10/30	10 x 30 mm

### Knives

H Code	Item Description	Suitable for
H080700070	Knife for AF-10/50 and 20/50	AF head 10/50 and 20/50
H080700071	Knife for AF-10/80 and 20/80,SL70	AF head 10/80 and 20/80, SL-70
H080700072	Knife for AF-10/120	AF head 10/120
H080700079	Knife for AF-6/30 and 8/30	AF head 6x30 and 8x30
H08D003699	Knife for AF-16/80-TB	AF head 16/80 TB
H08D003642	Knife for AF-16/120-TB	AF head 16/120 TB

### Cutting pads

H Code	Item Description	Suitable for
H080702058	Cutting pad for AF-1201	AF-305 and AF-605 To be cut to length
H08D004769	Cutting pad for AF-305	AF-305 only
H08D004748	Cutting pad for AF-605	AF-605 only
H08D004175	Aluminium cutting pad for HabaSYNC timing belt	AF-305 AF-605 only

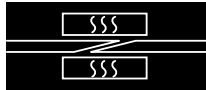

## 1.4 Accessory/spare part orders

Spare parts and accessories can be directly ordered from the manufacturer.

Address: Habasit Italiana S.p.A.  
Via del Lavoro, 50  
I-31016 CORDIGNANO (TV)  
Tel ++39 438 91 13  
Fax ++39 438 91 2374

Clearly specify the required parts.

ATTENTION	The use of other branded spare parts that do not meet Habasit specifications is prohibited. Habasit is not liable to consequences derived from the use of non original Habasit spare parts.
-----------	--

## 1.5 Warranty

All tools are subject to attentive final inspection. They are guaranteed free of material and factory defects for 1 year provided they are used correctly.

## 1.6 Technical consulting

Our experts are available for all consultations. For technical questions on cutting device operations and conditions, contact the manufacturer (for contact information, see 1.4).

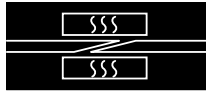

## 2 Operating mode

- The AF-05 punch cutter series exploits the application of a gusset cylinder to generate adequate drive to cut the belt. After positioning the belt, punch cut moving forward one pitch at a time, using the gusset cylinder to lower the cutting head.

**ATTENTION** A preset punch cut pitch must be equal to the distance between the cutting head knives in use. Inconsistency causes incorrect cuts with consequent material loss.

- Head carriage pitch movement is bi-directional; belts can be punch cut in both directions.

### 2.1 Preliminary operations

**CAUTION** Punch cutter use requires the manipulation of parts with cutting blades. Avoid touching or accessing the cutting head work area during operations.

### 2.2 Transport

4 handles (1) for the AF-305 and 4 lift rings (2) (eye screws) with 4 support handles for the AF-605 are included to lift the punch cutter. Before lifting, close and even tighten any auxiliary lifting systems such as belts, cords, etc.



AF-305

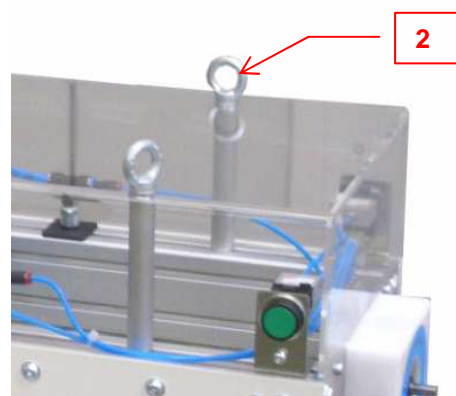

AF-605 lifting rings (eye screws)

**ATTENTION** Never use lifting points other than those specifically foreseen to lift the machine.

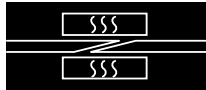

## 2.3 Compressed air connection

The machine is connected to the compressed air supply by the inlet fitting (1). Do not exceed maximum working pressure of 6MPa (6Kg/cm<sup>2</sup>).

The inlet fitting is ¼" and a supply tube with at least an 8 mm internal diameter is recommended.

Physical compressed air specifications:  
- Filtered, non-lubricated air



**CAUTION** Make sure effective pressure is at least 6 bar (Kg/cm<sup>2</sup>).

## 2.4 Flex cutting head installation

- To facilitate this operation, removing the belt lock rods on both sides is recommended to have free access to the chamber.
- Move the head carriage to mid work stroke to have the flex head housing accessible.

**ATTENTION** Disconnect compressed air supply before replacing the head.

- Unscrew the two screws (1) with a Nr. 13 Allen key; Only two turns are required to release the lock dowel.
- Remove the head and insert a new head, pushing it fully in to limit stop (2).
- Tighten the two screws to lock the head in place.

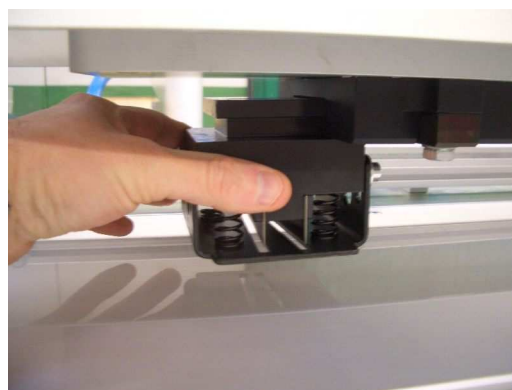
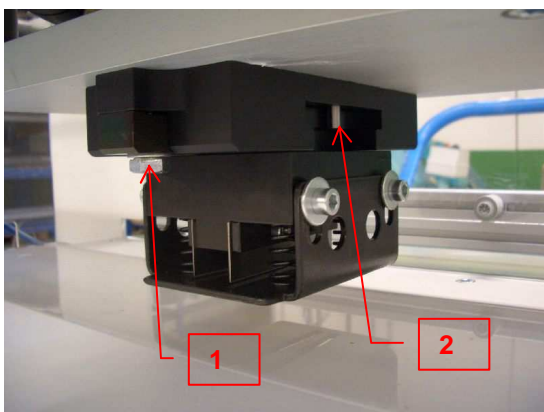

Select the appropriate cutting head recommended by Habasit for the product to be punch cut.

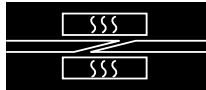

## 3 Punch cutting

### 3.1 Preliminary operations

The range of Habasit products that AF-05 series punch cutters can cut is very wide; in addition to all tapes and power belts up to 8 mm thick, HabaSYNC series timing belts up to AT-20 or XH size can be punch cut with the specific 80 x 16 flex cutting head.

Follow the procedure in paragraph 2.4 to assemble the appropriate flex head with the selected cutting geometry.

- ❑ Place the head and zero point which is at the end opposite the carriage push handle side (1). In this starting position, both pitch indexing pins must be inserted in their housings on the cam (2).

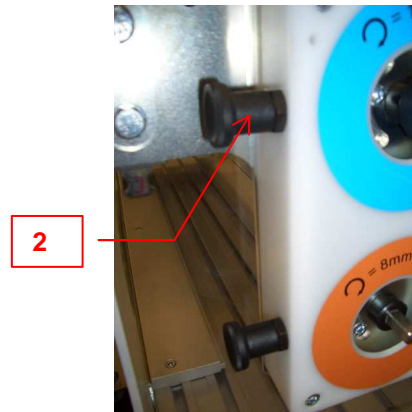
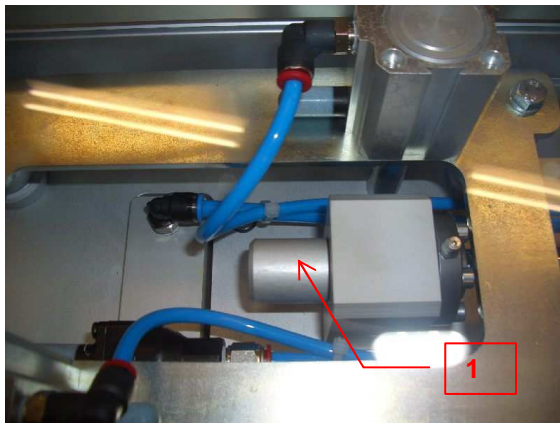

- ❑ Insert the product to be punch cut in the machine resting the edge against the fixed square on both the input and output sides. Rest the mobile squares against the other edge of the belt and lock them in place using the knobs.

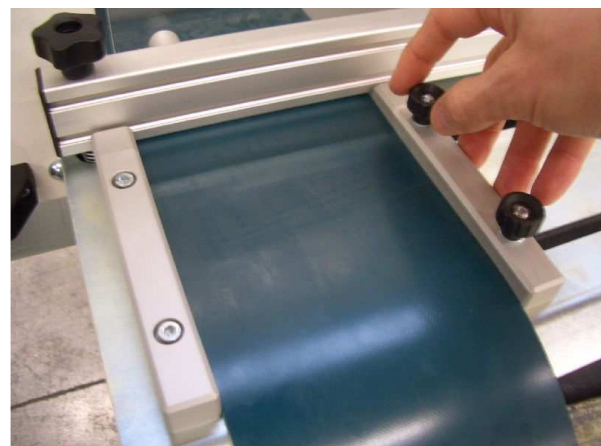



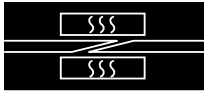

- ❑ Close the belt lock rods using the knobs.



- ❑ Select the correct pitch to be used according to the type of flex head installed. If the head has a 10 mm or 20 mm pitch, the blue cam is used excluding the orange cam by removing the pin and rotating it 90° so that it is raised.

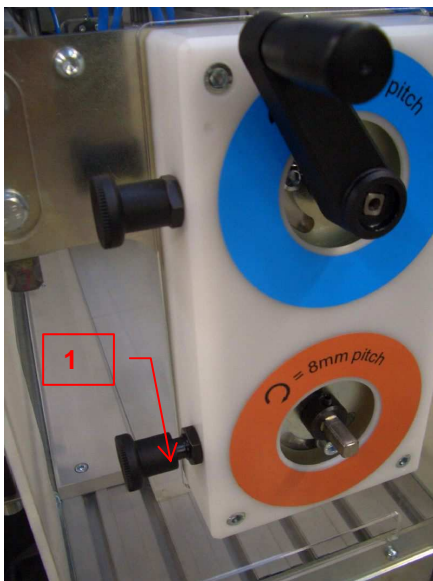

**Use with 10 or 20 mm pitch**  
Raise the pin (1) and rotate it 90°  
Place the handle on the blue cam

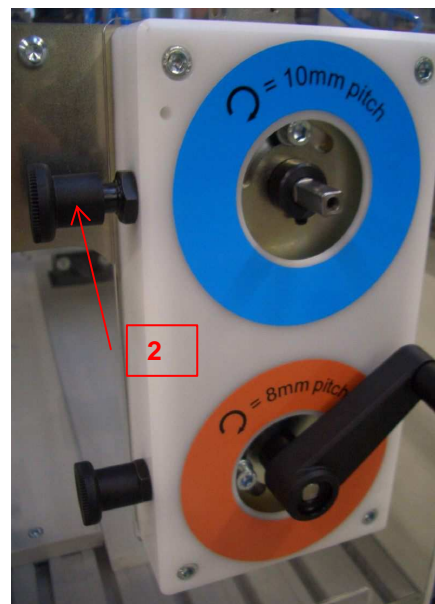

**Use with 8 or 16mm pitch**  
Raise the pin (2) and rotate it 90°  
Place the handle on the orange cam

This way only the concerned cam operates while the other freely rotates.

If both indexing pins are lifted and locked in position, the screw rotates freely to permit quick carriage movement.

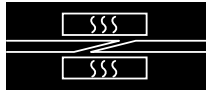

Check the nylon pad and its wear. If too marked by the knives, move it a few mm right or left to exploit the entire surface. It has a long working life if correctly used.

When evenly marked by the knives, it can be regenerated by milling the surface 1 mm deep to eliminate knife marks.

HabaSYNC belt punch cutting

To correctly punch cut HabaSYNC belts, the following flex head models must be used:

H08D003641	Flex cutting head AF-16/120-TB	16 x 120 mm
------------	--------------------------------	-------------

For A-20, AT-20 and XH series belts, the 16x80 mm flex head must be used:

H08D004129	Flex cutting head AF-16/80-TB	16 x 80 mm
------------	-------------------------------	------------

Additionally, the nylon cutting pad must be replaced with the aluminium version:

Nylon cutting pad



Alu cutting pad



HabaSYNC cutting head widia knives are able to punch cut on aluminium cutting pads without ruining them.

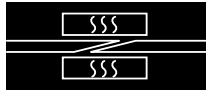

### 3.2 Flex punch cutting operations

1. Refer to the preliminary operations to prepare the machine and belt to be cut. The belt can be cut once these operations are completed.
2. Always start from the zero carriage position.
3. Simultaneously press the two buttons (1); The head lowers to cut the material. Release the buttons several seconds after the head reaches limit stop to be sure the cut is complete.
4. Once familiar with operations, the operator will recognise when the cut is complete by the typical noise the knives make during operations. The buttons can be released at that point.

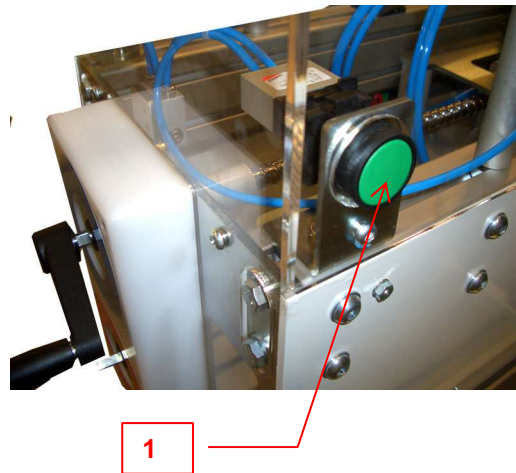

5. Release one or both buttons immediately causes the head to lift.
6. After cutting, lift the indexing pin (2) and rotate the cam one turn. During rotation, release the pin that will stop the cam at the end of the turn. If foreseen pitch is double the one generated by one cam turn, repeat the operation.
7. Repeat punch cutting (3) by pressing both buttons simultaneously.
8. Repeat the operations (3) and (6) until the belt is fully cut.

<b>CAUTION</b>	Do not introduce hands or objects under the cutting head. Injury or cutting head damage hazard.
----------------	---

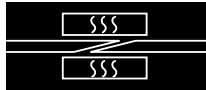

## 4 Assistance

### 4.1 Faults

**ATTENTION** Maintenance and/or repairs on freely accessible pneumatic parts must be performed by skilled specialized personnel

- For faults of this or other types, inform the manufacturer.

### 4.2 Knife replacement on the cutting head

Follow the instructions below to replace the cutting knives on the heads:

- Unscrew the 4 screws (1) that secure the belt press and screws (2) on the guide dowel;
- Remove the belt press and internal pressure springs;
- Unscrew the screws (3) that hold the knives, remove the knives and insert the new ones being careful to fully insert the knife in its housing;
- Tighten the screws (3) to lock the knife in place;
- Assemble the springs and belt press by tightening the screws.

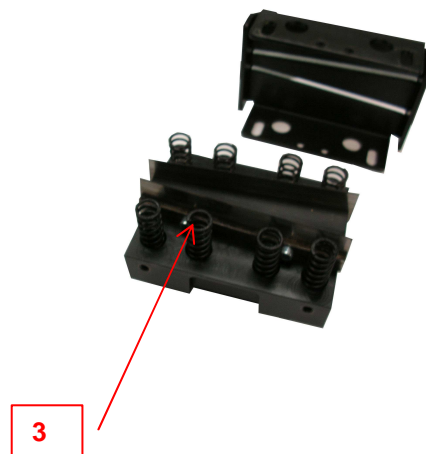
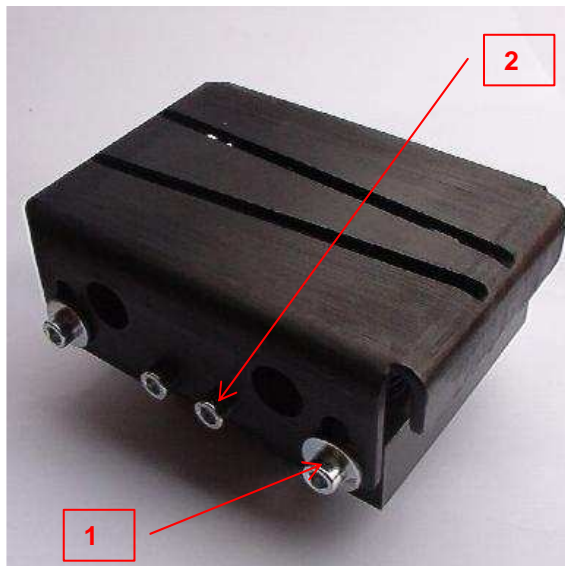

### 4.3 Maintenance

**ATTENTION** Maintenance personnel must be aware of the mechanical and electrical safety devices.  
Maintenance personnel must be authorized

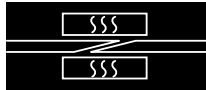

#### 4.4 Routine maintenance

**ATTENTION** Before performing any maintenance, make sure electrical, pneumatic and water supplies are disconnected and the pneumatic circuit depressurized.

**Table 5.3.1 Periodic maintenance**

Operation	Period	Personnel	Method
Cleaning	Daily	Operator	Clean the machine after use removing residue deposits
Check cutting pad wear	Daily	Maintenance worker	Check cutting pad wear and move or replace it as necessary
Check compressed air fittings and inlets	Monthly	Maintenance worker	Check for leaks
Check Plexiglas guard integrity	Monthly	Maintenance worker	Make sure there are no breaks or cracks in the protective panels

#### 5.1.1 Extraordinary maintenance

Extraordinary maintenance must be conducted at a Habasit Italiana SpA branch unless otherwise specifically authorised and agreed with the customer.

Contact:

Habasit Italiana S.p.A.  
Via del Lavoro, 50  
Zona Industriale  
I - 31016 Cordignano (TV)  
Tel.: 0039. (0) 438.9113  
Fax: 0039. (0) 438.200545

Clearly specifying the machine model, serial number, problems or faults found and documenting all problems as thoroughly as possible, even with photos.

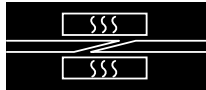

## 5 Technical Specifications

### 5.1 AF-305 and AF-605 punch cutter technical specifications

**TABLE 1 - PNEUMATIC CHARACTERISTICS**

Fluid characteristics	Filtered, non-lubricated air
Minimum supply pressure	6 bar (0.6MPa or 6Kg/cm <sup>2</sup> )
Min. supply diameter	Rapid connector of ¼"

**TABLE 2 - DIMENSIONS AND ENVIRONMENTAL CHARACTERISTICS**

	<b>AF-305</b>	<b>AF-605</b>
Dimensions (LengthxWidthxHeight) (including handles)	800x770x590 mm 31.49 x 30.31 x 23.22 in	1100x770x590 mm 43.3 x 30.31 x 24.8 in
Total Weight	kg / lbs.	
Noise level	<70 db	
Working temperature	Between 5° – 45°	
Humidity tolerance	Between 45 – 70%	

**TABLE 3 - CHARACTERISTICS OF WORKABLE ELEMENTS**

	<b>AF-305</b>	<b>AF-605</b>
Max length of belt	300 mm / 47.24 in	600 mm / 47.24 in
Max width of belt	14 mm / 0.55 in	14 mm / 0.55 in

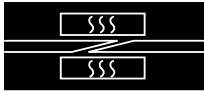

### AF-05 series punch cutter pneumatic diagram

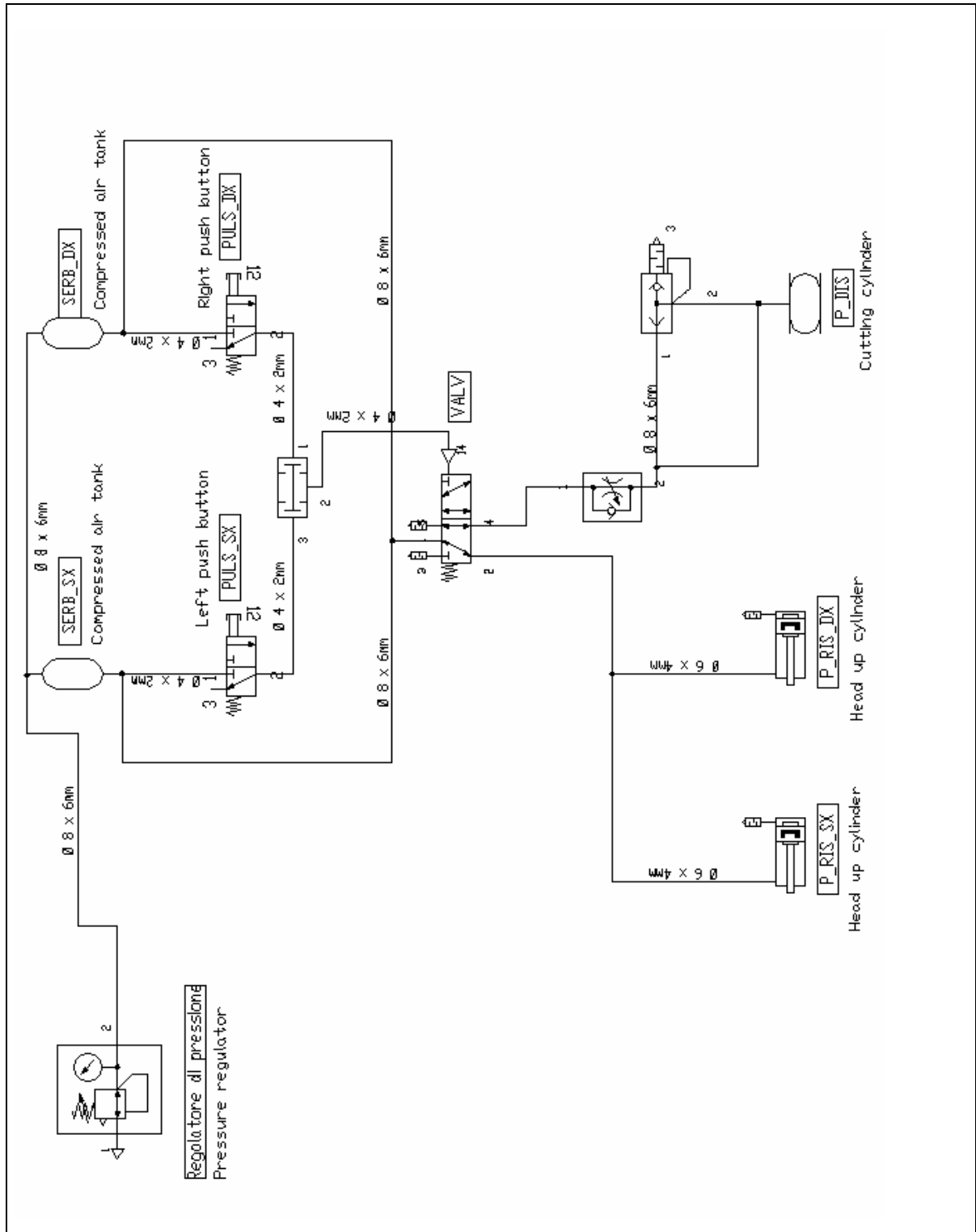

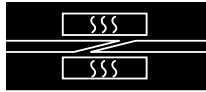

# AF-305/0 & AF-605/0

## Manual punch cutter for flex

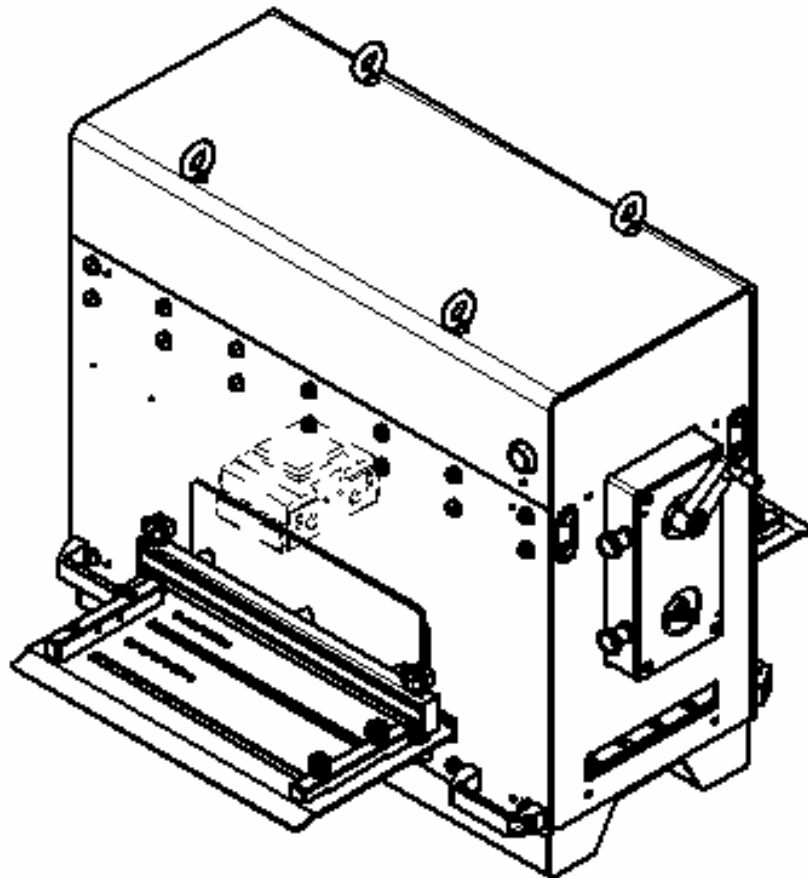

Spare parts manual and machine diagrams



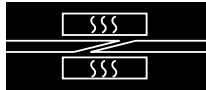

## 6 Preface

Habasit thanks you for purchasing the PM-09/160W-458 range press. If treated with care, the PM-09/160W-458 series press is able to guarantee reliability and junction quality for many years.

**In order to ensure correct and safe press use, the user must carefully read this manual and strictly follow the instructions before installation and use.**

For any question or problem concerning your press, please contact Habasit Customer Care. You can find the Habasit branch or dealer near you at [www.habasit.com](http://www.habasit.com).

### 1.7 Manufacturer's address

For further information, contact our headquarters at the following address:

Habasit Italiana S.p.A.  
Via del Lavoro, 50  
I - 31016 Cordignano (TV)

Tel.: 199 199 333  
Fax: 199 199 555

For international calls only:  
Phone: +39 0438 911444  
Fax: +39 0438 912374

### 1.8 Technical consulting

Our experts are available for all consultations.

For technical questions regarding equipment operations and conditions, please contact the manufacturer (paragraph 0).

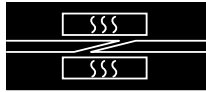

## 7 Regulations and general warnings

### 7.1 Manual layout criteria

This manual observes the organizational rules and requirements of Directive 98/37/CE, duly amended, being the Directive of the Council of the European Community of 14 June 1989, concerning the reconciliation of the laws of member states regarding machines, also known as the «Machine Directive», and also all the other Directives and Regulations referred to in the said Machine Directive, inspired by criteria which, in addition to illustrating the technical characteristics of the machine and its use, maintenance and troubleshooting methods, also clearly indicate the following:

- All the protection measures adopted on the machine, fully integrating design safety planning and construction safety
- All protection measures to be adopted to meet those risks that cannot be completely eliminated
- All indications for the training of personnel using the machine, while indicating where it is necessary to provide for individual safety protection devices.
- The manual is divided up into sections. Each section deals with a specific subject in which every aspect of safety is considered and clearly highlighted in the text.

### 7.2 Manual use criteria

HABASIT encourages the reader to fully read this manual when receiving the equipment it comes with and, in any case, before handling the equipment. This manual is designed to provide all the instructions, indications and warnings needed by the user to learn about the equipment, understand its main operating principles and be suitably informed for safe use.

In addition to the instructions in this manual, we would ask users to observe any specific current laws.

This manual must be considered as an essential part of the equipment. Its contents must be made known to the entrusted maintenance persons and users.

The purpose is to provide all the information required for good, correct use of the equipment.

The manuals must be kept throughout the equipment's life and must be updated in the event of modifications aimed at improving the equipment's performance.

The manuals must be available to qualified personnel.

Consultation of this manual is facilitated by the general index on the first page, which makes it possible to immediately find the subject of interest.

If the subject dealt with is particularly important it is highlighted with references to the type of technical personnel required to intervene.

All updates HABASIT considers necessary to improve the quality of the equipment will be communicated by way of sending of further specific documentation or a new manual to replace the previous one.

Should the equipment be transferred to another customer, manuals must be included and HABASIT informed in order to provide future modifications or updates.

A copy of this manual, delivered with the equipment, is meant for the maintenance operators, who shall read and keep it near the equipment, and consult it before undertaking any action on the equipment.

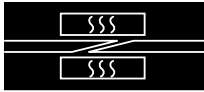

### 7.3 Dimensions

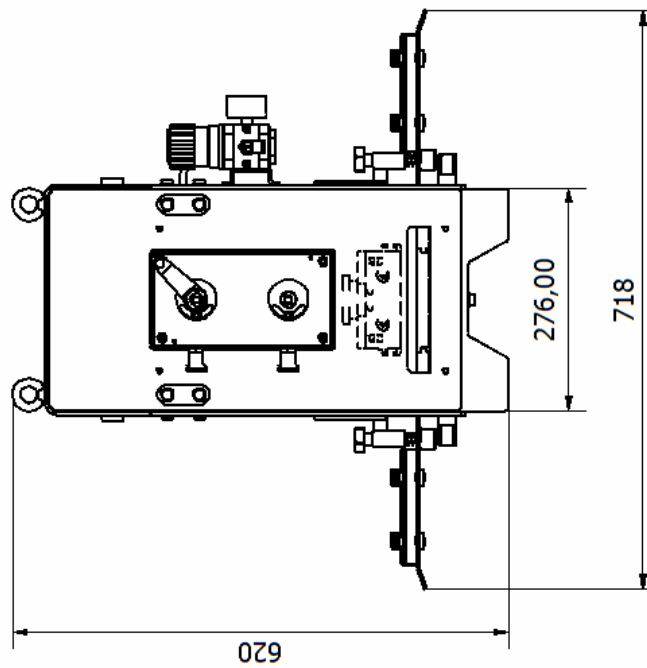
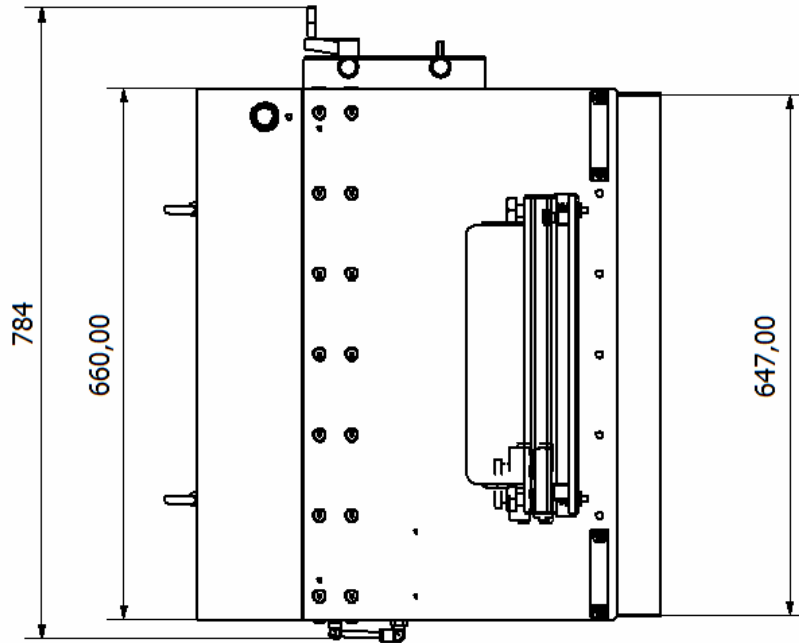



## 8 Spare parts

### 8.1 Complete machine group

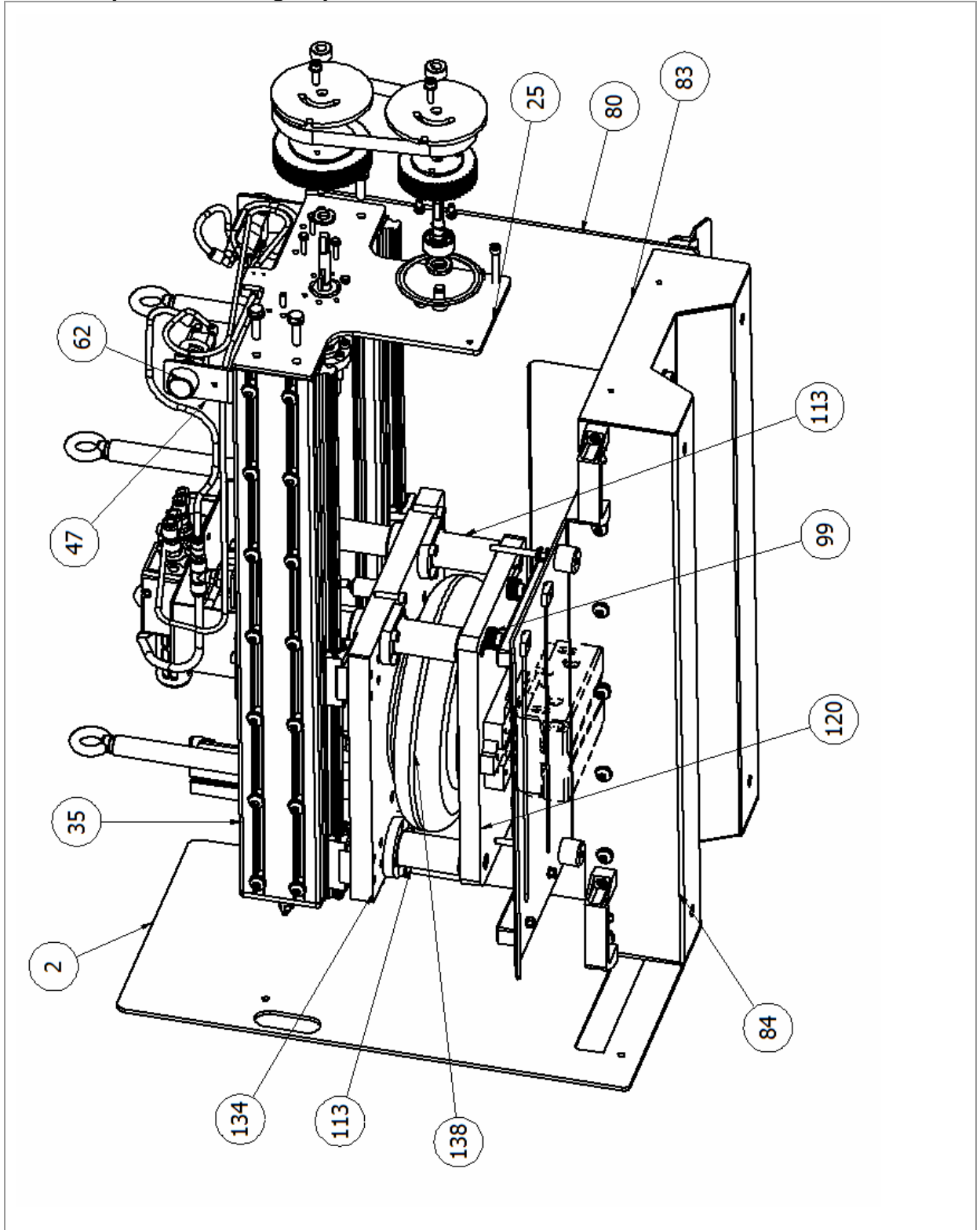



**Flex punch cutter  
AF-305/0 & AF-605/0**

**Complete machine group  
ID004762 – AF-305  
H08D004711 – AF-605**

POS.	QTY	CODE	DESCRIPTION
2	1	ID004716	RIGHT GUARD
25	1	ID004718	LEFT HEAD
35	2	ID004777	SUPPORT PROFILE ITEM 40x80 art. 0002604
35	2	ID004761	<b>AF-605</b> SUPPORT PROFILE ITEM 40X80 ART. 0002604
47	2	ID004733	START BUTTON BRACKET
62	2	IN020251	BLACK BUTTON 9290_T_22_GE6_0
80	1	ID004768	LEFT STRUCTURE PLATE
80	1	ID004747	<b>AF-605</b> LEFT STRUCTURE PLATE
83	2	ID004756	WELD LID
84	1	ID004774	REINFORCEMENT AND SUPPORT PLATE
84	1	Id004755	<b>AF-605</b> REINFORCEMENT AND SUPPORT PLATE
99	4	IN011785	GROOVED KNOB BT.20 FP-M6
113	4	ID004738	SLEEVE CARRIAGE
120	1	ID004736	GUIDE FASTENING PLATE
134	1	ID004735	CARRIAGE PLATE
138	1	XN000031	GUSSET CYLINDER 36489 EB-250-85 FESTO



## 8.2 Support beam and carriage movement group – ID004763

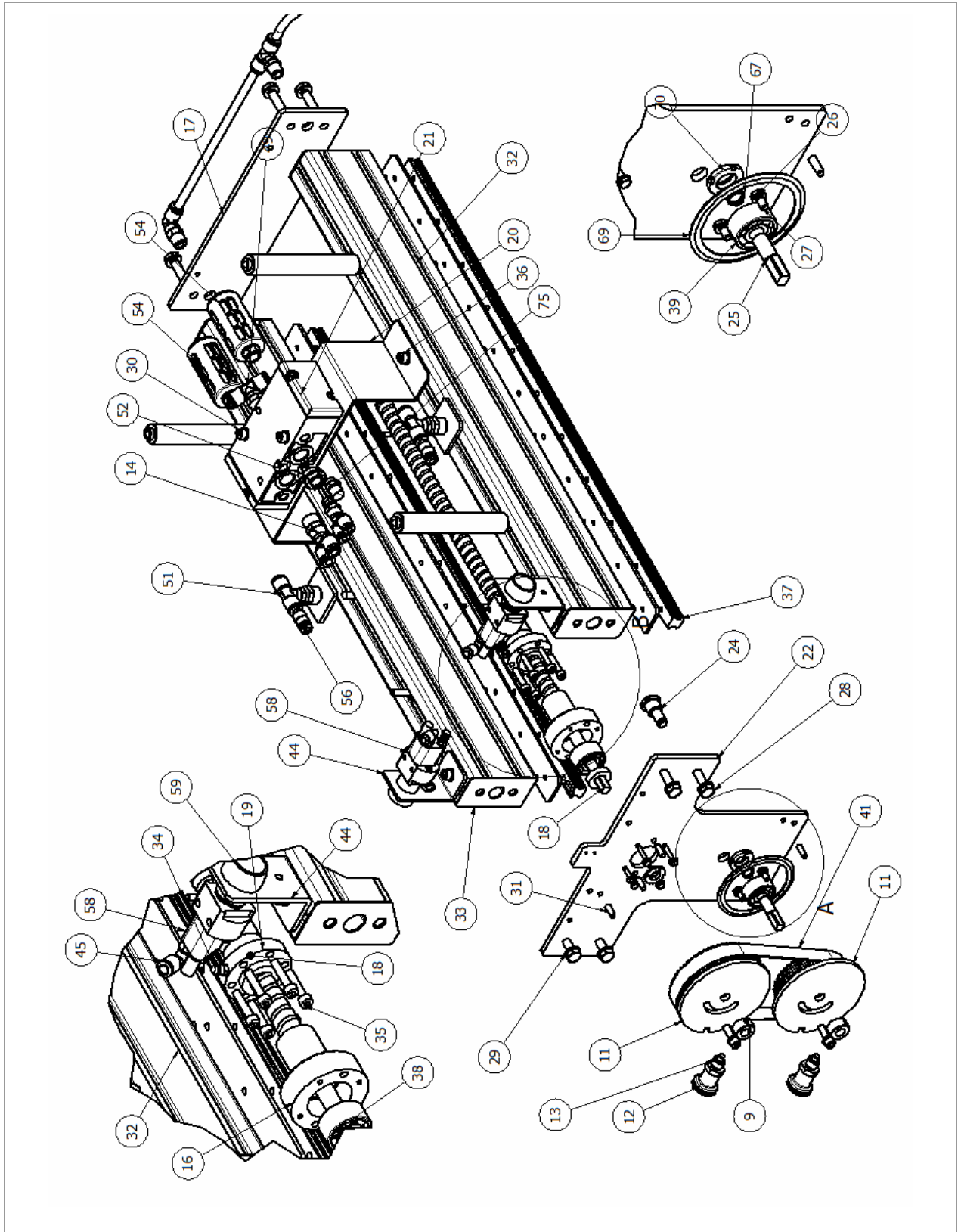



**Flex punch cutter  
 AF-305/0 & AF-605/0**

**Support beam and carriage movement group  
 H08D004763 – AF-305  
 H08D004714 – AF-605**

POS.	QTY	CODE	DESCRIPTION
9	2	XN000006	POSITIONING RING GN 705-10-E
11	2	ID004724	DISC WITH NOTCH
12	2	XN000001_1	GN 607.1_PART1 - INDEXING PLUNGERS WITH REST POSITION
13	2	XN000001_2	GN 607.1_PART2 - INDEXING PLUNGERS WITH REST POSITION
14	1	XN000004	COUPLING 153143_QSY_3_8_86_0
16	1	ID004721	BEARING PRESS
17	1	ID004722	RIGHT HEAD
18	1	ID004775	BALL SCREW VCS 16X10
18	1	ID004719	<b>AF-605</b> – BALL SCREW VCS 16X10 L=845
19	1	XN000056	WORM SCREW RU1610 VCS
20	1	ID004720	VALVE SUPPORT
21	1	XN000003	PNEUMATIC VALVE 14952_VL_5_3_8_B6_0
22	1	ID004718	LEFT HEAD
24	1	ID004728	PULLEY PIN 48
25	1	ID004760	WELD PIN FOR CRANK
26	3	IN010061	WASHER DIN 125 - A 5,3
27	3	XN000025	ALLEN SCREW DIN 933 - M5 X 10
28	8	IN011641	SCREW UNI 5739-M8X35 GALVANIZED
29	8	IN010009	UNI 6592-8.5X21 GALVANIZED WASHER
30	6	XN000023	ALLEN SCREW DIN 912 – M6 X 45
31	4	XN000016	PARALLEL PIN ISO 8734 - 5 X 16 - A
32	2	ID004777	<b>AF-305</b> SUPPORT PROFILE ITEM 40X80 ART. 0002604
32	2	ID004761	<b>AF-605</b> SUPPORT PROFILE ITEM 40X80 ART. 0002604
33	4	XN000009	GASKET 8 80X40PE 0.0.420.80 ITEM
34	1	XN000027	LUBRICATION NOZZLE, CONIC TYPE A DIN 71412 - AM 6
35	6	IN010595	ALLEN SCREW DIN 912 - M5 X 25
36	4	IN010064	ALLEN SCREW DIN 912 - M6 X 12
37	2	XN000051	AF-305 GUIDE HGR15R-640 HIWIN
		XN000010	<b>AF-605</b> GUIDE HGR15R-640 HIWIN
38	1	XN000021	ANGULAR CONTACT BALL BEARINGS DIN 628 SKF - SKF 3201 A-2RS1
39	1	XN000020	ANGULAR CONTACT BALL BEARINGS DIN 628 SKF - SKF 3200 A-2RS1
41	1	XN000008	TOOTHED BELT AT 5-500/16
44	2	ID004733	START BUTTON BRACKET
45	2	XN000012	COUPLING A L 533850_QSL_F_M5_66_0
49	1	XN000015	COUPLING A T 130945_QST_B_3_8_8_106_0
51	3	XN000014	COUPLING A T 130943_QST_B_1_4_8_206_0
52	1	IN020014	REDUCTION 3581_D_1_4I_3_8A6_0
54	2	IN020110	MUFFLER 2309 U-3/8
56	2	XN000018	REDUCTION 153042_QS_8H_66_0



Author:

Page 24 of 33

Edition: 08

Save modifications

Substitutes: =

58	2	IN020099	VALVE 3/2 PANEL 6817_SV_3_M56_0
59	2	IN020251	BLACK BUTTON 9290_T_22_GE6_0
67	1	IN010140	ELASTIC STOP RING
69	1	XN000055	PULLEY FLANGE B19





### 8.3 Support beam and carriage movement group – ID004763

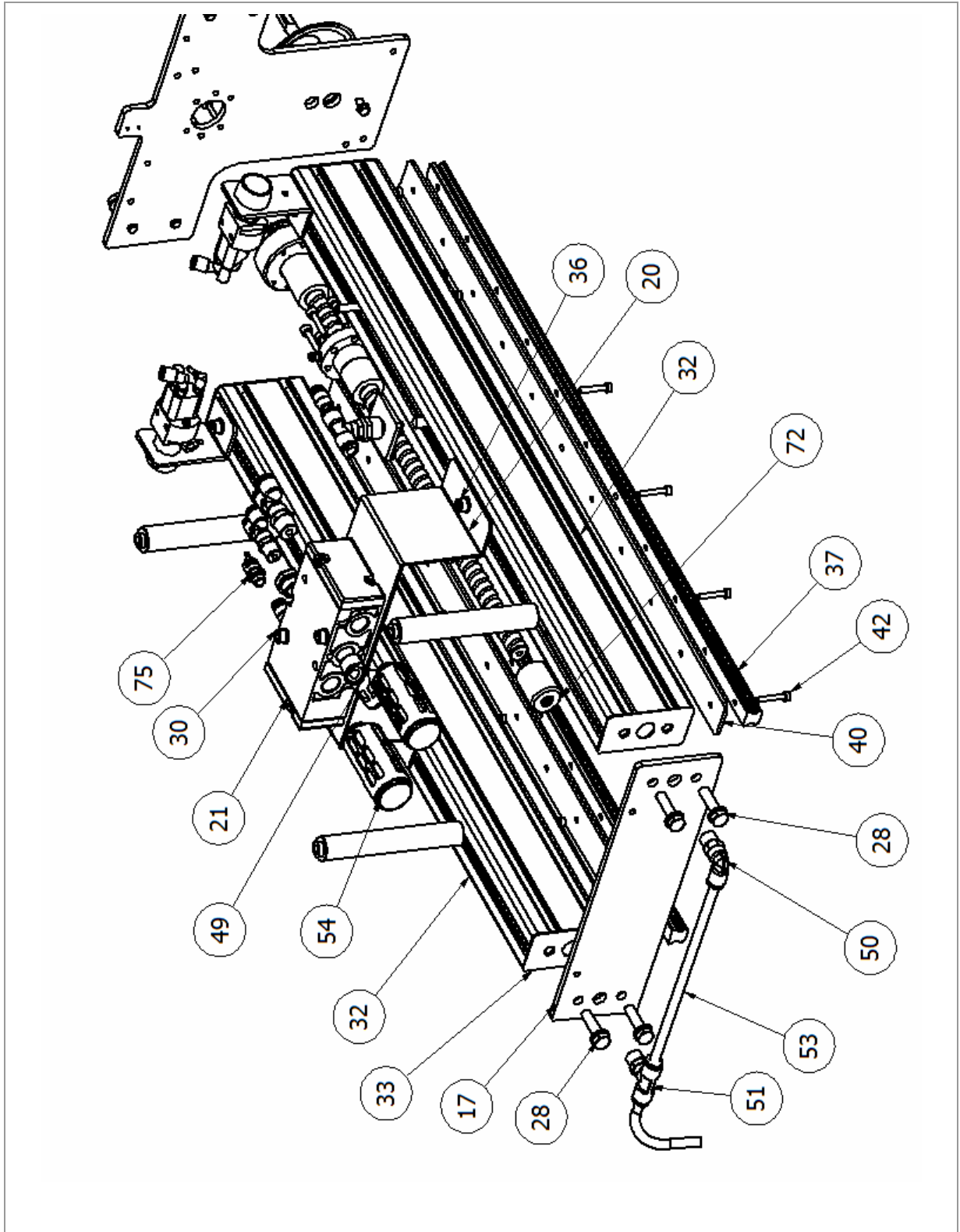



Flex punch cutter AF-305/0 & AF-605/0			Support beam and carriage movement group - H08ID004763 – AF-305 H08D004714 – AF-605
POS.	QTY	CODE	DESCRIPTION
17	1	ID004722	RIGHT HEAD
20	1	ID004720	VALVE SUPPORT
21	1	XN000003	PNEUMATIC VALVE 14952_VL_5_3_8_B6_0
28	8	IN011641	SCREW UNI 5739-M8X35 GALVANIZED
30	6	XN000023	ALLEN SCREW DIN 912 - M6 X 45
32	2	ID004777	AF-305 SUPPORT PROFILE ITEM 40X80 ART. 0002604
32	2	ID004761	<b>AF-605</b> SUPPORT PROFILE ITEM 40X80 ART. 0002604
33	4	XN000009	GASKET 8 80X40PE 0.0.420.80 ITEM
36	2	IN010064	ALLEN SCREW DIN 912 - M6 X 12
37	2	XN000051	AF-305 GUIDE HGR15R-640 HIWIN
37	2	XN000010	<b>AF-605</b> GUIDE HGR15R-640 HIWIN
40	2	ID004776	AF-305 – REINFORCEMENT PLATE FOR SUPPORT
40	2	ID004730	<b>AF-605</b> - REINFORCEMENT PLATE FOR SUPPORT
42	12	IN011744	ALLEN SCREW RICA DIN 912 - M4 X 25
49	1	XN000015	COUPLING A T 130945_QST_B_3_8_8_106_0
50	1	XN000013	COUPLING A L 130931_QSL_B_1_4_8_206_0
51	3	XN000014	COUPLING A T 130943_QST_B_1_4_8_206_0
53	1	XN000041	TUBE SECTION 8
54	2	IN020110	MUFFLER 2309 U-3/8
72	1	ID004732	REAR CARRIAGE LOCK SHIM
75	1	XN000060	COUPLING FESTO 11955 LCN 1/8 PK 3



### 8.4 Carriage movement group – pitch indexing system detail

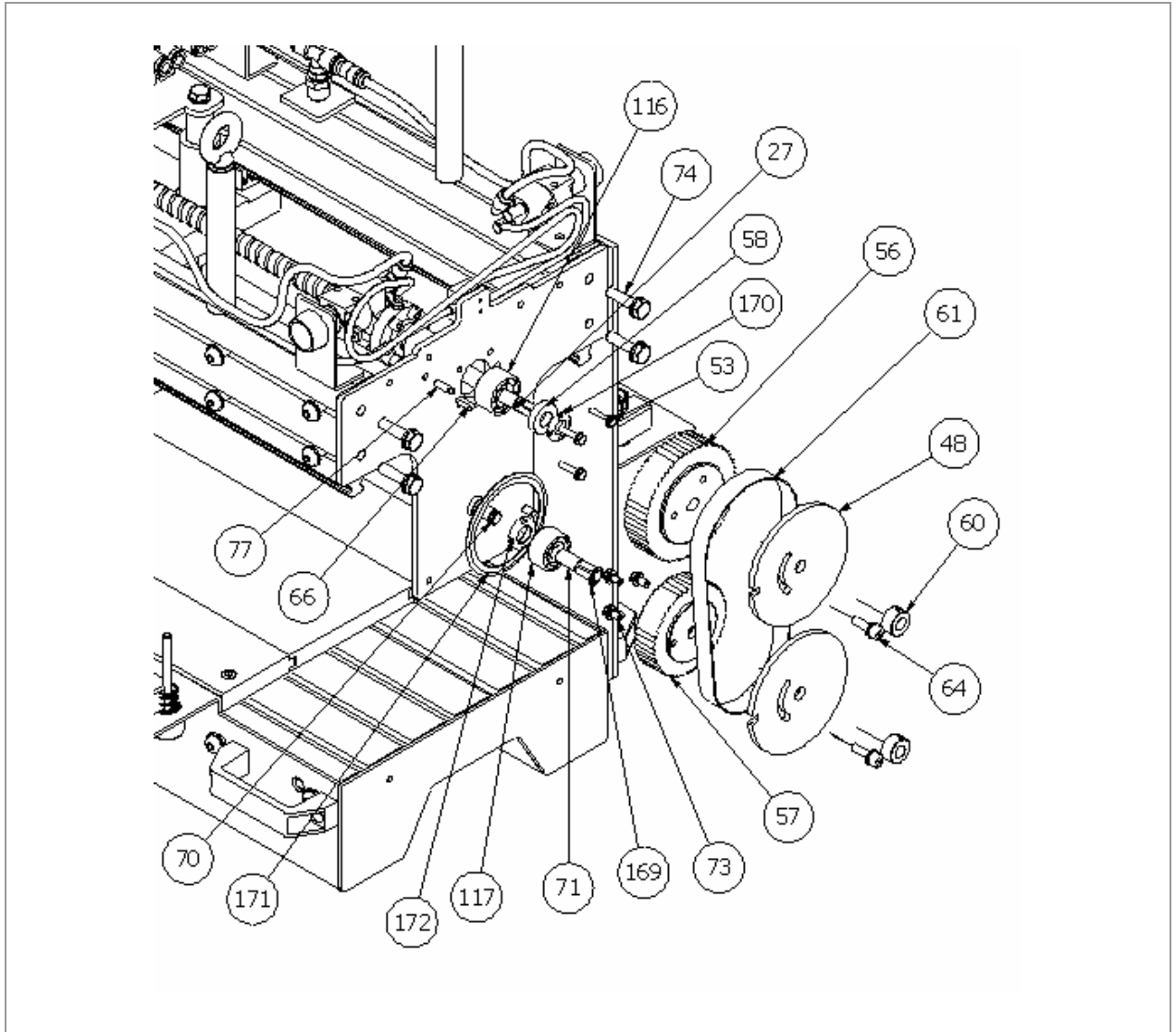



Flex punch cutter AF-305/0 & AF-605/0			Carriage movement group – pitch indexing system detail
POS.	QTY	CODE	DESCRIPTION
27	1	ID004775	BALL SCREW VCS 16X10
48	2	ID004724	DISC WITH NOTCH
53	4	XN000024	ALLEN SCREW DIN 933 – M4 X 20
56	1	ID004726	PULLEY 27 AT 5/60-6
57	1	ID004727	PULLEY 27 AT 5/48-6
58	1	ID004725	SHIM WASHER
60	2	XN000006	POSITIONING RING GN 705-10-E
61	1	XN000008	TOOTHED BELT AT 5-500/16
62	1	XN000007	CRANK MT.64 AS-8X8
63	10	IN010065	WASHER DIN 125 - A 6,4
64	6	IN010020	ALLEN SCREW DIN 912 - M6 X 20
66	1	XN000022	PARALLEL KEY DIN 6885 - A 4 X 4 X 16
70	1	ID004728	PULLEY PIN 48
71	1	ID004760	WELD PIN FOR CRANK
73	3	XN000025	ALLEN SCREW DIN 933 - M5 X 10
74	8	IN011641	SCREW UNI 5739-M8X35 GALVANIZED
77	4	XN000016	PARALLEL PIN ISO 8734 - 5 X 16 - A
116	1	XN000021	ANGULAR CONTACT BALL BEARINGS DIN 628 SKF - SKF 3201 A-2RS1
117	1	XN000020	ANGULAR CONTACT BALL BEARINGS DIN 628 SKF - SKF 3,200 A-2RS1
169	1	IN010140	ELASTIC STOP RING
170	1	IN011767	GROOVED ROUNDED NUT DIN 981 - KM 1
171	1	XN000055	PULLEY FLANGE B19
172	1	IN010189	GROOVED ROUNDED NUT DIN 981 - KM 2



### 8.5 Group – ID004674 frame group

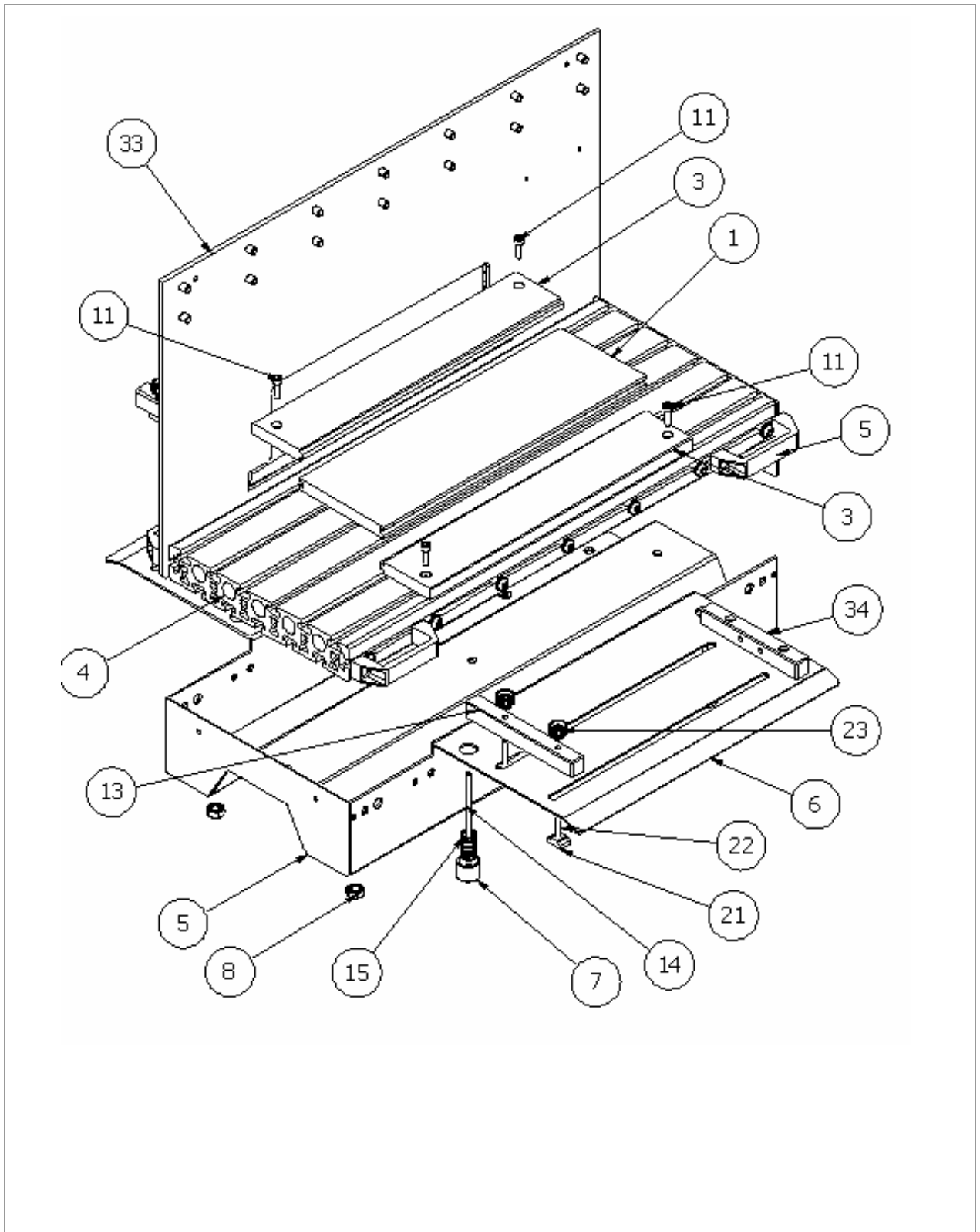



Flex punch cutter AF-305/0 & AF-605/0			ID004764 – frame group
POS.	QTY	CODE	DESCRIPTION
1	1	ID004769	NYLON CUTTING PAD
1	1	ID004748	<b>AF-605</b> – NYLON CUTTING PAD
3	2	ID004771	CUTTING PAD GUIDE
3	2	ID004750	<b>AF-605</b> – CUTTING PAD GUIDE
4	1	ID004770	EXTRUDED ALUMINIUM PROFILE BOSCH 45X270 COD. 3842992927/643
4	1	ID004749	<b>AF-605</b> - EXTRUDED ALUMINIUM PROFILE BOSCH 45X270 COD. 3842992927/643
5	2	ID004756	WELD LID
6	1	ID004774	REINFORCEMENT AND SUPPORT PLATE
6	1	ID004755	<b>AF-605</b> - REINFORCEMENT AND SUPPORT PLATE
7	4	ID004757	STUD LOCK
8	4	IN010271	ALLEN NUT DIN 934 - M10
11	4	IN010020	ALLEN SCREW DIN 912 - M6 X 20
13	2	ID004751	FIXED GUIDE
14	4	ID004752	THREADED STUD
15	4	XN000034	SPRING 16X30
18	4	XN000050	PROFILE CAP 0037011 40X20 BLACK
19	4	XN000057	HAND WHEEL LOBI VCT.32B-M6 - 69844
21	4	ID004753	ANTI-ROTATION NUT M6
22	4	ID004754	THREADED BAR M6
23	4	IN011785	GROOVED KNOB BT.20 FP-M6
25	1	XN000038_1	159580_LR_3_8_D_MIDI6_01
33	1	ID004779	RIGHT STRUCTURE PLATE
33	1	ID004747_01	<b>AF-605</b> – RIGHT STRUCTURE PLATE
34	2	ID004780	FIXED GUIDE
36	4	XN000061	HANDLE M.443/110-CH - BLACK 37001 ELESA



## 8.6 Group – ID004764 – Main frame

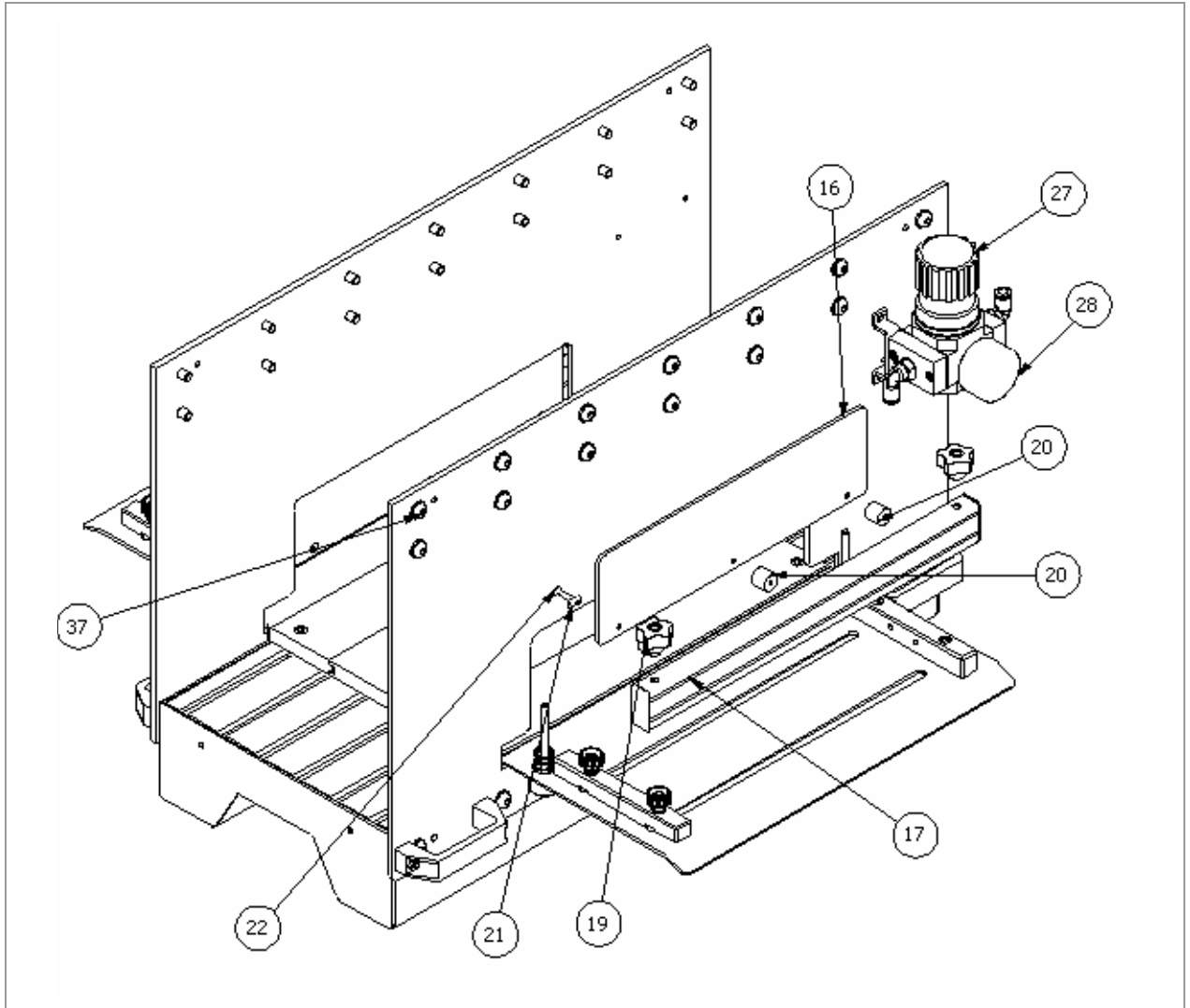



Author:

Page 32 of 33

Edition: 08

Save modifications

Substitutes: =

Flex punch cutter AF-305/0 & AF-605/0			ID004764 – AF-305 frame group ID004714 – AF-605 frame group
POS.	QTY	CODE	DESCRIPTION
16	2	ID004773	AF-305 – PLEXIGLASS SLOT GUARD
16	2	ID004759	<b>AF-605</b> - PLEXIGLASS SLOT GUARD
17	2	ID004772	PROFILE 5 40X20 2N180 ITEM
17	2	ID004758	<b>AF-605</b> - PROFILE 5 40X20 2N180 ITEM L=
19	4	XN000057	HANDWHEEL LOBI VCT.32B-M6 - 69844
20	6	ID004778	PLEXIGLAS PRESS SHIM
21	6	XN000122	SLIDING DOWEL ITEM M4 HOUSING 5 - 0.0.370.06
22	6	IN011518	SCREW TCSEI - DIN 7991 - M4x25
27	1	XN000038	159580_LR_3_8_D_MIDI6_01
28	1	XN000038	159580_LR_3_8_D_MIDI6_02
37	28	XN000058	SCREW VTBEI M8x16
19	4	XN000057	HANDWHEEL LOBI VCT.32B-M6 - 69844





## 9 Product and product use liabilities

The customer is liable for correct product selection and use according to his industrial and/or commercial needs unless use was recommended by Habasis technicians, duly informed by the customer on operating needs. In this case, special instructions for use must be indicated in the order and confirmed by Habasis. The customer is always liable for product use safety.

**ALL THE TECHNICAL INDICATIONS IN THIS CATALOGUE ARE ACCURATE AND RELIABLE. THEY ALWAYS REFER TO STANDARD USE AND ARE THE RESULTS OF TESTS CONDUCTED ON EQUIPMENT IN REDUCED SCALE. THEY SHOULD BE CHECKED BY THE CUSTOMER ACCORDING TO INTENDED INDUSTRIAL USE AND ESPECIALLY FOR SPECIAL APPLICATIONS FOR WHICH ANY MANUFACTURER RECOMMENDATIONS, NOT INDICATED IN THE ORDER AND ORDER CONFIRMATION, ARE MERELY INDICATIVE, WITHOUT ANY GUARANTEE ON THEIR ABILITY TO PROVIDE THE DESIRED RESULT NOR ANY LIABILITY REGARDING END PRODUCT QUALITY OR HABASIT PRODUCT'S CORRESPONDENCE TO THE CUSTOMER'S PRODUCTION NEEDS AND FINAL RESULTS WHICH ARE NOT UNDER THE MANUFACTURER'S CONTROL. THEREFORE, IN THIS CONTEXT, HABASIT SHALL NOT BE LIABLE FOR FAULTS, DEFECTS OR DAMAGES ASSOCIATED WITH THE USE OF THEIR PRODUCTS.**