



HD VIDEO IP STREAMER



CT-HDVD-HDSTR-KIT

MADE IN CHINA

Read this user manual carefully before using this product. Pictures shown in this manual are for reference only.

Safety Precaution

Please read all instructions carefully before using the device. Save this manual for further reference.

- Follow basic safety precautions to reduce the risk of fire, electrical shock and injury to persons.
- Do not dismantle the housing or modify the module to avoid electrical shock or burn.
- Using supplies or parts not meeting the products' specifications may cause damage, deterioration or malfunction.
- Do not expose the unit to rain, moisture or install this product near water.
- Install the device in a place with adequate ventilation
- Do not twist or pull by force the ends any cables.
- Do not use liquid or aerosol cleaners to clean this unit. Always unplug the power to the device before cleaning.
- Unplug the power cord when left unused for a long period of time.
- Refer all servicing to qualified service personnel.

Introduction

The CABLETRONIX CT-HDVD-HDSTR-KIT is a HD Video over IP streamer including a transmitter and a receiver (CT-HDVD-HDSTR-RX). Featuring HDMI and IP ports, the CT-HDVD-HDSTR-KIT features real-time AV encoding (transmitter) and decoding (receiver) to broadcast up to 1080p (max) HDMI signal from 1 transmitter to 1 or several receivers point to point or through an Ethernet Switch. It can be powered by PoE for up to 200m/656ft via single CAT6.

The CT-HDVD-HDSTR-KIT is ideal in various applications, digital signage and video surveillance and monitoring.

Features

- HD interface for digital audio and 1080p@60Hz (max) video up to 175/200m or 574/656ft with CAT5e/CAT6 utilizing a PoE Ethernet switch; 60m or 196ft point to point
- RJ45 port for Ethernet Interchange connection
- HDMI 1.3& HDCP 1.3 compliant
- Auto adjusting indicator for power connection& signal transmission status
- Broadcast HDMI signal from 1 transmitter to 1 or several receiver(s)
- Powered by power adapter or Ethernet Switch with PoE solution
- Compact design for easy operation

Package List

No.	Accessories
1	CT-HDVD-HDSTR-KIT: 1 x Transmitter, 1 x Receiver, 2 x Mounting ears 4 x Screws, 8 x Plastic cushions, 1 x User manual
2	Power Adapter: 2 x Power Adapter (DC 5V 1A)

Connection

The figure below illustrates a typical connection that can be utilized in a point-to-point configuration using a CT-HDVD-HDSTR-KIT with one CT-HDVD-HDSTR-RX unit allowing up to 196' using CAT6 cable.

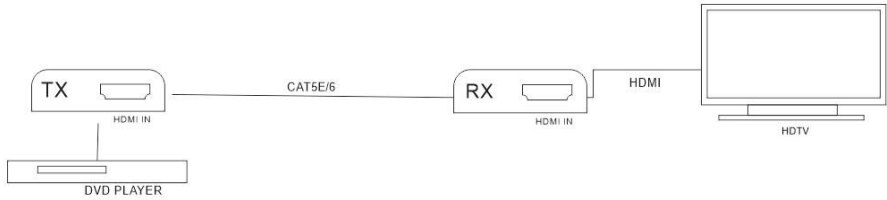

Connection

The figure below illustrates a typical connection that can be utilized with the CT-HDVD-HDSTR-KIT1 and more than 1 CT-HDVD-HDSTR-RX with an Ethernet switch.

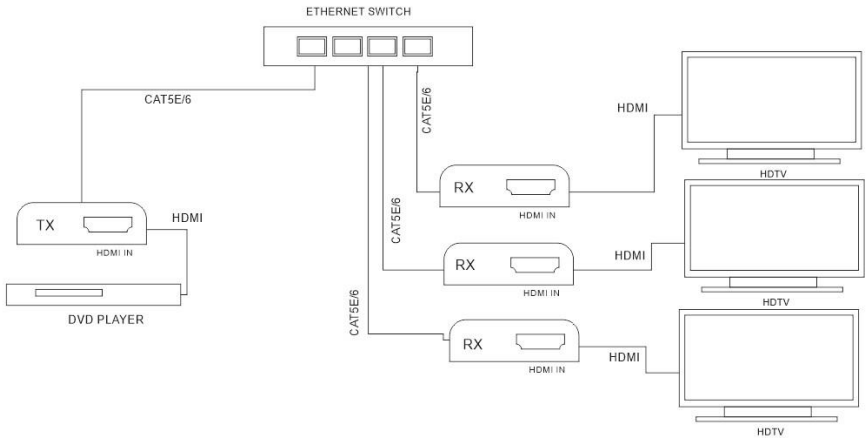

One or more CT-HDVD-HDSTR-RX may be utilized in this case to broadcast signal from 1 CT-HDVD-HDSTR-KIT to 1 or more CT-HDVD-HDSTR-KIT2.

Specification

Input			
Input	1 HDMI, 1 IP		
Input Connector	1 female type A HDMI 1.4, 1 RJ45		
Min/ Max Signal Level	T.M.D.S. 2.9V~3.3V		
Output			
Output	1 HDMI, 1 IP		
Output Connector	1 female type A HDMI 1.4, 1 RJ45		
Min/ Max Signal Level	T.M.D.S. 2.9V~3.3V		
Output Impedance	Differential 100Ω		
Standards	Compliant with HDMI 1.3& HDCP 1.3		
General			
Transmission Distance	60m/196ft (CAT5e/6) If used with Ethernet switch: 200m/656ft (CAT6) 175m/574ft (CAT5e)	Power Consumption	CT-HDVD-HDSTR-KIT1: 4.2W CT-HDVD-HDSTR-KIT2: 3.5W
Power Supply	DC 5V 1A	Resolution	1080P@60Hz(Max)
Temperature	0 ~ 50°C/32 ~ 122°F	Humidity	10% ~ 90%
Weight	80g/2.82oz	Dimension	121x21x60mm 4.7x.9x 2.3in (W*H*D)

CABLETRONIX 1-Year Limited Warranty

CABLETRONIX. (the "Company") warrants to the Original Purchaser that the item purchased is free from defects in workmanship or material under normal use. This warranty starts on the date of shipment of the hardware to the Original Purchaser.

During the warranty period, the Company agrees to repair or replace, at its sole option, without charge to Original Purchaser, any defective component. To obtain service, the Original Purchaser must return the item to the Company properly packaged for shipping. All defective products must be returned to the Company within thirty (30) days of failure. Products must be returned with a description of the failure and Return Merchandise Authorization (RMA) number supplied by the Company. To receive a RMA number and a return shipping address on where to deliver the hardware, call 610-429-1821. The shipping, and insurance charges incurred in shipping to the Company will be paid by Original Purchaser, and all risk for the hardware shall remain with the Original Purchaser until such time as Company takes receipt of the hardware. Upon receipt, the Company will promptly repair or replace the defective unit, and then return said unit to Original Purchaser, shipping prepaid. The Company may use reconditioned or like-new parts or units, at its sole option, when repairing any hardware. Repaired products shall carry the same amount of outstanding warranty as from original purchase. Any claim under the warranty must include dated proof of purchase or invoice. In any event, the Company's liability for defective hardware is limited to repairing or replacing the hardware.

This warranty is contingent upon proper use of the hardware by Original Purchaser and does not cover: if damage is due to Acts of God (including fire, flood, earthquake, storm, hurricane or other natural disaster), accident, unusual physical, electrical, or electromechanical stress, modifications, neglect, misuse, operation with media not approved by the Company, tampering with or altering of the hardware, riot, war, invasion, act of foreign enemies, hostilities (regardless of whether war is declared), civil war, rebellion, revolution, insurrection, military or usurped power or confiscation, terrorist activities, nationalization, government sanction, blockage, embargo, labor dispute, strike, lockout or interruption or failure of electricity, air conditioning, or humidity control, internet, network, or telephone service

The warranties given herein, together with any implied warranties covering the hardware, including any warranties of merchantability or fitness for a particular purpose, are limited in duration to one year from the date of shipment to the Original Purchaser. Jurisdictions vary with regard to the enforceability of warranty limitations, and you should check the laws of your local jurisdiction to find out whether the above limitation applies to you.

The Company shall not be liable to you for loss of data, loss of profits, lost savings, special, incidental, consequential, indirect, or other similar damages arising from breach of warranty, breach of contract, negligence, or other legal action even if the Company or its agent has been advised of the possibility of such damages, or for any claim brought against you by another party. Jurisdictions vary with regard to the enforceability of provisions excluding or limiting liability for incidental or consequential damages. You should check the laws of your local jurisdiction to find out whether the above exclusion applies to you.

This warranty allocates risks of product failure between Original Purchaser and the Company. The Company's hardware pricing reflects this allocation of risk and the limitations of liability contained in this warranty. The warranty set forth above is in lieu of all other express warranties, whether oral or written. The agents, employees, distributors, and dealers of the Company are not authorized to make modification to this warranty, or additional warranties binding on the Company. Accordingly, additional statements such as dealer advertising or presentations, whether oral or written, do not constitute warranties by the Company and should not be relied upon.

This warranty gives you specific legal rights. You may also have other rights which vary from one jurisdiction to another.