

# Pool-2000

## Installation and Operating Manual



Always wear personal protective equipment such as gloves and safety glasses when working with potentially hazardous chemicals.



Caution—Refer to accompanying documents.



Caution—Risk of electric shock



Electrical installation of this equipment should only be performed by trained personnel in accordance with local electrical wiring regulations (in North America, refer to NEC and CSA, C22.2 CEC Part 1). Before working with this equipment, isolate it from any electrical source and lock out/tag out.



A circuit breaker must be included in the installation's building. It must be installed in close proximity to the equipment and within easy reach of the operator, and it must be marked as the disconnecting device for the equipment.



Additional documentation for Pool 2000 units can be found at: <http://www.beta-technology.com>.



If equipment is used in a manner not specified by the manufacturer, the protection provided may be impaired.

## INTRODUCTION

The Pool-2000 is a time-activated water-resistant peristaltic pump for industrial applications. Up to 24 events may be programmed with variable run times for each event from one second to 19 minutes and 50 seconds. The Pool-2000 operates a 7-day clock in which events can be programmed to occur every day or only on particular days throughout the week. A back up battery keeps the clock running in the event of an interruption in the electrical power.

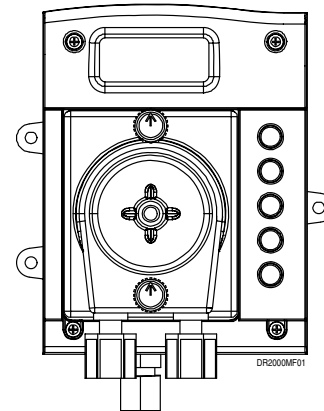

Figure 1a. Pool-2000

## PREFACE

This manual describes how to install, setup, operate and maintain the Pool-2000. Material in this manual is subject to change without notice. Manual revisions will be made on an as needed basis. Special circumstances involving important design, operation or application information will be released via Equipment Technical Bulletins.

© Copyright 2009 Beta Technology, Inc.

## SAFETY

These symbols on the unit mean:

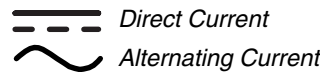

## SPECIFICATIONS

### OPERATING CONDITIONS

Ambient Operating Temperature  
5 to 40°C (41 to 104°F)

Electrical Power  
115V~ 50/60 Hz 0.1A or 230V~ 50/60 Hz  
Voltage fluctuations up to +/- 10% of nominal voltage.

Altitude  
Max operating altitude 2000 meters (6500 feet)

Humidity  
Max relative humidity 80% for temperatures up to 31°C (87.8°F), decreasing linearly to 50% relative humidity at 40°C (104°F).

Ratings  
Intended for indoor or outdoor use (CSA approved for indoor use only).

## TIMING CAPABILITY

Up to 24 different times per period. Daily, weekly, or mixed schedule; variable run time 1 second to 19 minutes and 59 seconds.

## DIMENSIONS

Size	Height	Width*	Depth**
Inches	5.6	4.6	4.8
Centimeters	14.2	11.6	12.2

\*Width includes feet

\*\*Depth with SnapHead pump cartridge in place.

### Weight

1.85 lbs/0.84 kg

### Volume Per Day Output

Flex Tube 0.125" ID: 9.0 GPD/34 liters LPD at 30 psi/2.07 bar

## COMPONENTS

### Enclosure

Molded ABS plastic, water-resistant, flame-resistant

### Pump

Peristaltic, self-priming and self-checking, 6 Volts DC

### Speed & Displacement

100 rpm, 2.5 oz per minute at 30/74 milliliters  
30 psi/2.07 bar nominal\*

Max duty cycle 19 min. 59 sec ON, 20 min. OFF.

*\*Actual values may vary depending on operating conditions. We recommend that you test output at startup and at regular intervals for optimum performance.*

### Hydraulic Performance

**Maximum Vacuum:** 12 in of mercury

**Maximum Pressure:** 30 psi

### Tubing Material

Flex

### Coin Battery

3 Volt Lithium BR2032 or CR2032 – See **OFF-SEASON STORAGE INSTRUCTIONS—PRESERVING PCB BATTERY LIFE AND PROGRAMMING DATA** in the **MAINTENANCE** section for instructions on preserving battery power and storing the unit during the off-season.

### Regulatory

	CE	NSF50	CSA
<b>Pool-2000</b>	✓	✓	115V only

For confirmation of regulatory compliance, see rating label on your Pool-2000.

## INSTALLATION



Refer installation and service to qualified personnel only.

Installation must comply with all applicable plumbing and electrical codes.



Disconnect power from circulation system before replacing tubing.

## INSTALLING THE TUBING INTO THE PUMP CARTRIDGES

The Pool-2000 comes with the pump cartridges affixed to it without tubing. Following these instruction for installing the tubing into the pump cartridge.

1. Make sure the Pool-2000 is powered off.

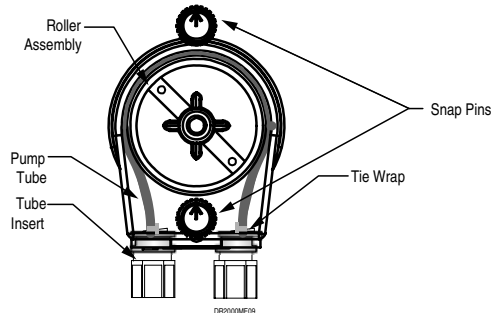

Figure 1b. SnapHead Pump Cartridge

2. Turn the SnapHead pins to the left or right to remove the pump head.
3. Loosen but do not remove the small screw at the bottom of the rear cover and lift the cover from the cartridge.
4. Coat the inside radius of the pump cartridge (the part that comes in contact with the tubing) with Dow Corning III lubricant.
5. Place the squeeze tube inside the pump cartridge.
6. Press the two tube inserts into the cartridge so that the tie wrap "buckles" face toward the center of the pump. **The tube must not be twisted during the assembly.**
7. Replace the rear cover and tighten the screw.
8. Push the black SnapHead pins back into position, with the arrow pointing up or down.

## MOUNTING

The Pool-2000 should be mounted so the LCD screen can be viewed easily. It should be located close enough to both the injection point and liquid supply to ensure unobstructed delivery.

1. Align the metal mounting bracket and mount on a smooth surface using screws.
2. Place the Pool-2000 over the mounting bracket and slide it down tight.

- If desired, a screw can be placed in one of the feet to hold the unit in place.

**NOTE**  The Pool-2000 can also be mounted using the three plastic feet. If mounting on an uneven surface, be careful not to over-tighten or snap the feet off.

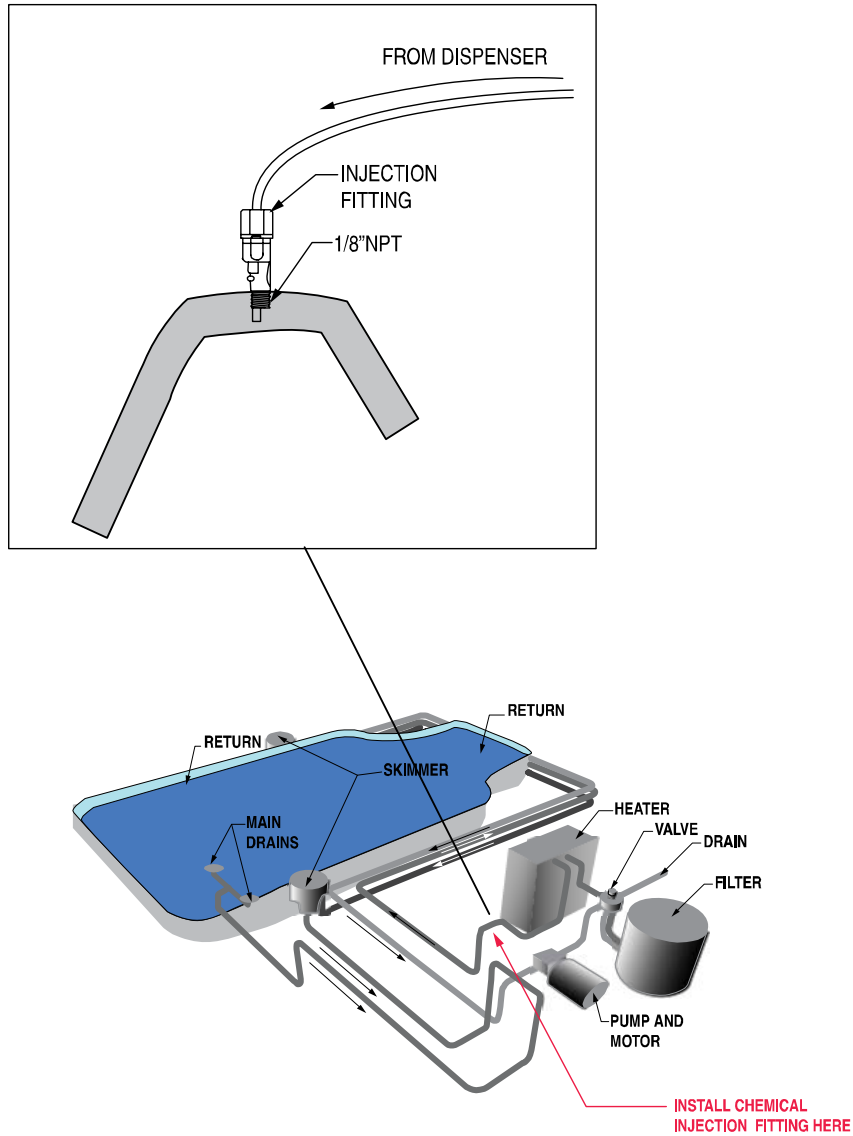

Figure 2. Pool-2000 Full Installation

## INSTALLING SUPPLY LINES

- Cut the desired length of 1/4-inch (6mm) chemical feed line and attach it to the nut of the left side (suction side) of the pump squeeze tube.

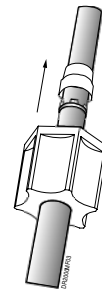

Figure 3. Installing the Chemical Feed Line to the Squeeze Tube Fitting.

- For the chemical uptake side, a standpipe is provided. Cut the bottom of the chemical feed line tubing at a 45-degree angle and press it into the standpipe. Insert the chemical feed line 0.5 inches (12 mm) above the bottom of the standpipe. Both the 45-degree cut and the 0.5 inch (12 mm) distance above the bottom of the standpipe will help avoid the formation of a seal with the bottom of the chemical drum and ensure an unobstructed chemical uptake.

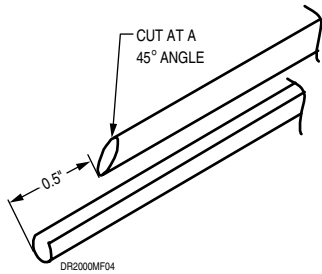

Figure 4. Cutting Chemical Feed Tubing, Inserting into Standpipe

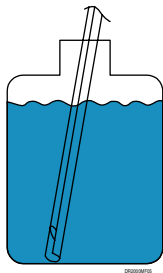

Figure 5. Chemical Feed Tubing (uptake side) with Standpipe in Chemical Drum

- Cut and connect the desired length of chemical feed line for the chemical delivery to the right side of the pump squeeze tube. Run the delivery tube to the desired injection point.

## POWER SUPPLY



*Dispenser power should be interlocked with circulation power supply.*

This unit comes with a standard power cord. No ground connection is required.

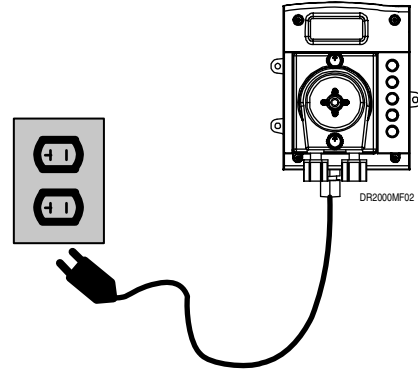

Figure 6. Plugging Pool-2000 into Outlet.



A 15 amp branch circuit protection (circuit breaker) must be included in the building's electrical installation. It must be installed in close proximity and within easy reach of the Pool-2000 operator. The circuit breaker must be marked as the disconnecting device for the Pool-2000. If the equipment is used in a manner not specified by the manufacturer, the protection provided may be impaired.

## OPTIONAL LOW LEVEL ALARM KIT

An optional low level (sonic) alarm and low level alarm lance are available (see Spare Parts list).

The low level alarm lance is inserted into the chemical drum and the sonic alarm is installed on the left side of the pump housing. Both are wired into the appropriate connectors on the main PCB. The lance detects when the chemical drum is empty and the sonic alarm issues an audible alarm.

Refer to the installation instructions in the low level alarm kit for more detailed instructions.

## SETUP & PROGRAMMING

During normal operation, the Pool-2000 is in Run Mode. In Run Mode, the screen will display the current time and day of the week, and the colon will blink once per second.

The Pool-2000 is programmed using the 5 buttons and screen in the front of the unit.

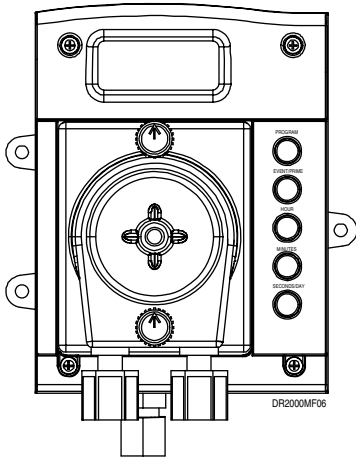

Figure 8. Pool-2000, Front Plate

## ENTERING PROGRAM MODE

To begin programming, you must first enter into Program Mode. To do this, hold down the Program button for 8 seconds. The colon will blink fast and irregularly while the Program button is pressed.

The screen will flash and the colon will stop blinking to indicate that you have successfully entered Program Mode. The screen display will not change. It will continue to show the current time and day of the week.

## SETTING THE CLOCK

Once you enter Program Mode, your first option is to set the clock. Use the Hours button and the Minutes button to change the time of day. The clock will display "P" for PM settings. Use the day button to change the day of the week. We recommend that you program Monday as day 1.

## PROGRAMMING WHEN AN EVENT WILL OCCUR

1. Press the Event button once. You will see the following screen. This screen indicates which event you are entering.

Example:



The screen above indicates that you are entering event number 1.

2. Press the Event button again. This screen shows the day and time this event will begin.
3. Change the time that the event will occur using the Hours and Minutes buttons.
4. Change the day of the week that this event will occur using the day button. When scrolling through the day menus you will see that you are able to select from the following options:
  - Select each day individually, as days 1 through 7.
  - Select all the days of the week, 1 through 7 appear together.
  - Select week day only, 1 through 5 appear together
  - Select weekend days only, 6 and 7 appear together

Example:

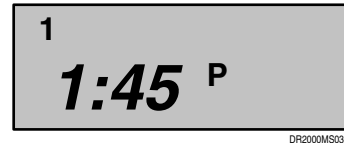

The screen above indicates that the event will occur at 1:45 PM every Monday (only Mondays).

Example:

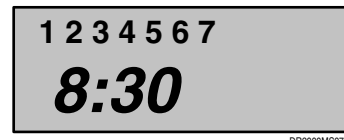

The screen above indicates that the event will occur all days at 8:30 AM (everyday).

## PROGRAMMING HOW LONG AN EVENT WILL BE

Once you have programmed when the event will occur, press the Event button again. The screen will display the day of the event and the duration of the event in Minutes and Seconds. Min:Sec will appear in the bottom of the screen. The maximum run time is 19 minutes and 59 seconds. Set the duration of the event using the Minutes button and the Seconds button.

Example:

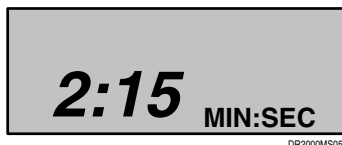

The above screen indicates that the event will have a duration of 2 minutes and 15 seconds.

Once you have finished programming the first event, press the Event button again to move to next event. You can program up to 24 events this way.



*In situations where two events have been programmed for the same time and day, the highest numbered event will be the one the Pool-2000 accepts. For example, if event #1 is set for 30 seconds at 2:00 on day 1 and event #4 is set for 10 seconds at 2:00 on day 1, event #4 will take precedence and the pump will activate for 10 seconds at 2:00 on day 1.*

## CLEARING UNWANTED EVENTS

As a rule, it is a good idea to clear events that you do not plan to use. This eliminates the occurrence of any unwanted events. To clear unwanted events:

1. Go to the event screen of the first event you want to clear.
2. Press and hold the Hours and Minutes buttons.
3. While still pressing the Hours and Minutes buttons, press and hold the Event button. The unit will scroll through all higher-numbered events and clear them (by setting the duration to "000").

The unit will stop clearing after event 24.

### Example of Clearing Unwanted Events

Let's say you've programmed events 1 through 5 and are not planning to use events 6 through 24. It is advisable to be sure that there are no events programmed for 6 through 24. To do this:

1. Go to the event 6 screen.
2. Press the Hours, Minutes and then Event buttons and hold them down. The unit will scroll from event 6 through 24, setting all values to "000". This process will stop when it returns to event 1. You now have events 1 through 5 as you programmed them and events 6 through 24 cleared.

## RETURNING TO RUN MODE

When you have finished programming, you can return to Run Mode by pressing the Program button once. The colon will again flash normally (once per second). If you leave the Pool-2000 in Program Mode and unattended for 2 1/2 minutes, it will switch back into Run Mode automatically.

You can be sure you are in Run Mode by pressing the Prime button and priming the pump. The Prime button will not prime the pump if you are not in Run Mode.

## PRIMING OR EXTRA SHOT

1. Ensure that you are in Run Mode.
2. Press the Prime button to operate the pump.

## MAINTENANCE



*Disconnect power from circulation system before replacing tubing.*



*Safety glasses and protective clothing should be worn while servicing the Pool-2000.*



*Refer installation and service to qualified personnel only.*

## OFF-SEASON STORAGE INSTRUCTIONS—PRESERVING PCB BATTERY LIFE AND PROGRAMMING DATA

The dispenser's PCB battery normally lasts about 10 years with continuous use. However, there may be times, like during the off-season, when your dispenser will be stored and left unused for months at a time. When the dispenser is unplugged and drawing backup power, the battery life is only about 6 months, and once the battery runs out, all programming is lost.

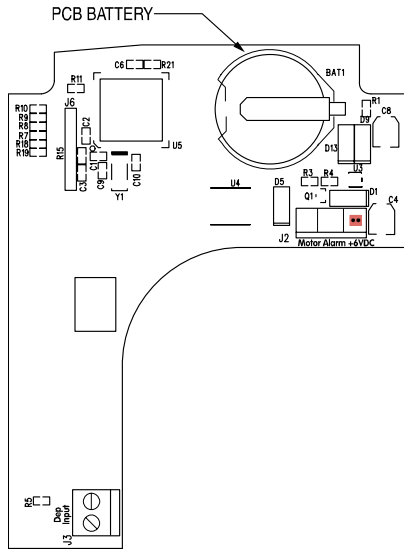

Figure 8.1. Pool-2000 Main PCB

Follow these steps to ensure maximum battery life and to retain programming data:

- If possible, store the dispenser plugged in. This will preserve its programming and preserve the life of the backup battery.
- If #1 cannot be done follow these steps:
  1. Store the dispenser for no more than 6 months. At startup of the new season, verify unit still has a working display. If so, plug unit into power source for 15-20 seconds. This will charge the capacitor on PCB.
  2. Remove the 4 screws on the front of the dispenser to access its PCB, but do not remove the harness between the PCBs.

**IMPORTANT: YOU MUST REPLACE THE OLD BATTERY WITH THE NEW ONE WITHIN 15 SECONDS OF REMOVING OLD BATTERY IN ORDER TO RETAIN PROGRAMMING.**

  3. Remove battery from battery holder on main PCB (needle-nose pliers may help).
  4. Replace battery with Beta item # 058942 **within 15 seconds of removal**. Reassemble. Programmed data should be intact.

## PERIODIC MAINTENANCE

### Pump & Squeeze Tube Replacement Schedule

Since every installation is different (chemicals, tube runs, operating frequency, and so on), an exact tube replacement schedule cannot be specified. With use, the tube slowly evolves from round to oval and the amount of chemical pumped decreases. By regularly checking the amount of chemical pumped, you can determine general tube life. It is recommended that you closely monitor the time it takes the original tube to reach the end of its flex life, and then establish a replacement schedule. Replacing tubes at regularly scheduled intervals

ensures more accurate product use and reduces service calls. In general, short feed lines of a large diameter will improve pump tube life.

## REPLACING PUMP CARTRIDGES

### To Remove

9. Turn off power to the unit to ensure that the pump does not run during maintenance.

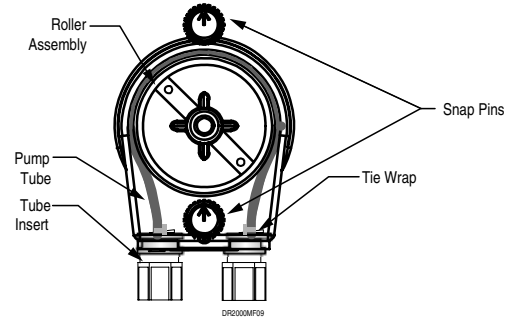

Figure 9. SnapHead Pump Cartridge

10. Remove the cartridge from the motor housing by twisting the snap pins at top and bottom 90° to the left or right.
11. Remove the supply and feed lines from the old pump squeeze tubing and connect them to the new pump squeeze tubing.

### To Install

1. Align and engage the pump drive spline with the motor gear by rotating the roller assembly.
2. Turn the snap pins so that the arrow is pointed up. Then push in until you hear a distinct click.

### Replacing Pump Squeeze Tubing



*Splash danger! Because the squeeze tube contains chemical product and is flexible, extra caution should be taken while changing the squeeze tube to insure that the chemical does not splash in the eyes or on the hands or clothing of the service person.*



*Always wear protective eyewear, gloves and protective clothing when changing the squeeze tube.*

1. Disconnect power from the dispenser.
2. Remove the cartridge as described above.
3. Loosen but do not remove the small screw at the bottom of the rear cover and lift the cover from the cartridge.
4. Pull the roller assembly out of the pump cartridge to release the pump squeeze tubing.
5. Pull the tube inserts out of the pump cartridge.
6. Remove the squeeze tube.
7. Coat the inside radius of the pump cartridge (the part that comes in contact with the tubing) with Dow Corning III lubricant.
8. Replace it with a new squeeze tube.

9. Press the two tube inserts into the cartridge so that the tie wrap "buckles" face toward the center of the pump. Remember, the tube must not be twisted during the assembly.
10. Replace the roller assembly.
11. Replace the rear cover.
12. Re-tighten the screw.

## How To Replace Pump Motor

### To Remove

1. Ensure that power is off.
2. Remove the 4 screws holding the front plate (bezel) in place.
3. Remove the front plate.
4. Remove the pump cartridge from the motor assembly, leaving the chemical lines attached.

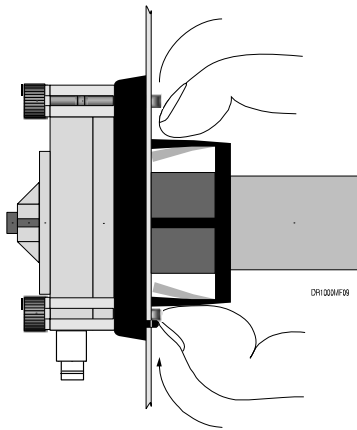

5. Remove the electrical connections at the back of the motor.
6. Compress the two flex ears on the back of the motor until the motor slides out through the hole in the front plate.

### To Replace

1. Locate the alignment tip of the motor housing so it is in the down position.
2. Slide the pump motor housing into the front plate hole. The holding ears will expand to hold the pump motor in place. Verify that both ears popped out and are locked in place.
3. Reinstall the electrical connections at the back of the motor.
4. Install the pump cartridge.
5. Prime the pump to verify proper pump rotation (clockwise). If the direction is wrong, switch the motor wires.

## How to Replace the Main PCB

1. Disconnect power to the unit.
2. Remove the 4 screws holding the front plate of the Pool-2000 control box in place. Remove the front plate (bezel), being careful not to damage the gasket.
3. Detach the power wire connection coming from the power PCB to the main PCB.
4. Detach the motor supply wires from the PCB.

5. Place the bezel face down on the work surface.
6. Remove the 4 screws holding the main PCB to the bezel.
7. Gently lift the main PCB out of the bezel.
8. If the zebra strips and display screen stick to the old PCB, remove them and place them in the bezel, being careful to keep their orientation.
9. Align the new PCB over the zebra strips and replace the 4 screws. Be sure to tighten the screws into position. The pressure these screws exert on the PCB is important for maintaining water resistance and holding the display in place.
10. Reattach the motor supply wires to the main PCB at the terminal marked "motor".
11. Reattach the power supply to the terminal marked "+6VDC".
12. Remount the front plate (bezel) and retighten the screws, being careful not to damage the gasket.



*Between the main PCB and the front plate (bezel) are the buttons, screen and zebra strips. It is important that these items are properly aligned and that the screws holding the PCB in place be properly tightened. If these items are not properly aligned and held in place by pressure from the 4 screws, water resistance may be lost around the buttons or the screen may not display properly.*

## How to Replace the Power PCB

1. Disconnect power to the unit.
2. Remove the 4 screws holding the front plate of the Pool-2000 control box in place. Remove the front plate (bezel), being careful not to damage the gasket.
3. Detach the power wire connection from the main PCB.
4. Battery must be replaced within 15 seconds to retain programming. See **Off-Season Storage Instructions—Preserving PCB Battery Life and Programming Data** at the beginning of the Maintenance section.
5. Detach the power cord.
6. Remove the screws holding the power PCB in place.
7. Gently lift out the power PCB.
8. Align the new power PCB and replace the screws. Be sure to tighten the screws into position.
9. Reattach the power cord to the terminal block.
10. Reattach the power wire connection from the main PCB.
11. Remount the front plate (bezel) and retighten the screws, being careful not to damage the gasket.

## How to Replace Coin Battery

1. Ensure that power is off.
2. Remove the 4 screws holding the front plate of the Pool-2000 control box in place. Remove the front plate (bezel), being careful not to damage the gasket.
3. Locate the coin battery on the PCB.



- Slip the coin battery out and replace it with a new one (3 Volt lithium BR2032 or CR2032).
- Remount the front plate (bezel) and retighten the screws, being careful not to damage the gasket.



*When the lithium backup battery is removed, all programmed events will be erased and the clock will revert to its default setting of 12:00 AM, Monday.*

### Cleaning the Unit

Wipe pump housing clean with a dry rag.

## TROUBLESHOOTING

### Pump Runs Continuously

If the pump runs without being activated, replace the main PCB.

### Pump is Running Backwards

Check that the polarity of the wires from the main PCB to the motor is correct.

### Pump Runs Too Slowly

- Check that the squeeze tube or pump cartridge is not jammed.
- Check the chemical uptake line for kinks.
- Verify that the chemical uptake line is not forming a seal against the side or bottom of the chemical drum (See: **INSTALLING SUPPLY LINES** in **INSTALLATION** section).
- If the liquid being pumped is very viscous the pump may labor in order to move it. Using a less viscous chemical, pumping shorter distances, setting longer run times, and assuring that the squeeze tube is in good condition will help address this issue.

#### Also:

- Verify that the correct line power is installed and adequate power is arriving to the unit.
- Check for 6.0 volts DC or greater at the motor connection wires with the motor disconnected and the pump prime button activated. If this voltage is present, replace the motor gearbox. If the problem persists after the motor gearbox has been replaced, replace the power PCB. If the voltage is absent replace the main PCB.

### Pump Will Not Run

- Check that the squeeze tube or pump cartridge is not jammed.
- Check the chemical uptake line for kinks.
- Verify that the chemical uptake line is not forming a seal against the side or bottom of the chemical drum (See: **INSTALLING SUPPLY LINES** in **INSTALLATION** section).
- Check to see that the motor connection wires are properly connected from the main PCB to the motor gearbox.
- Press the Program button once to assure that you are in Run Mode. If you are in Run Mode the colon should blink once per second. You must be in Run Mode for programmed events to occur.

- Push the Prime button and try to prime the pump. If the pump does prime, check that events are properly programmed.

#### Also:

- Verify that the power is connected.
- Check for 6 to 11 volts in the wire harness from the power PCB to the main PCB. If the voltage is absent replace the power PCB.
- Check for 6 volts DC or greater at the motor connection wires with the motor disconnected and the pump prime button activated. If this voltage is present, replace the motor gearbox. If the voltage is absent, replace the main PCB.



*For a programmed event to occur, the event must be programmed at least 1 minute in the future. If you return to Run Mode after the start of a programmed event, that event will not occur until the next programmed interval.*

Clock Resets to 12:00 AM and Events are Erased When Unplugged or Power is Lost  
Replace backup battery.

### Pump Will Not Operate When Programmed Interval Occurs

Check event programming. If setup is correct, and the prime switch activates the pump, replace the main PCB.

### Pump Will Not Pull Liquid from the Supply Container

- If there is too much vacuum created, the pump will not be able to move the chemical. This is easily recognized when the squeeze tubing collapses. If this happens:
  - Check that the squeeze tube or pump cartridge is not jammed.
  - Check the chemical uptake lines for kinks.
  - Ensure that the chemical uptake line is not forming a seal against the side or bottom of the chemical drum (See **INSTALLING SUPPLY LINES** in **INSTALLATION** section).
  - Using a less viscous chemical, pumping shorter distances, setting longer run times and ensuring that the squeeze tube is in good condition will help address the issue.
- Check to see that there is not an air leak somewhere along the chemical supply line.

## PRODUCT REPAIR

If an item is in need of repair, please call or write to obtain a Return Authorization (RA) number. Call Customer Service at 1-800-858-2382 (within the U.S.A) or 831-426-0882. They provide RA numbers. Then, please write the number on the outside of the box before sending. It is very helpful to our Repair Department to include a note explaining the nature of the problem. Failure to obtain an authorization number before returning an item may delay repair of the equipment.

## SPARE PARTS

<b>Item #</b>	<b>Description</b>
1203652	Flex tube, 0.125 ID
1206740	Pump cartridge without tube
058942	Main PCB battery
093288	Dow Corning III lubricant
1202397	PCB, Main
1202396	PCB, Power 115V
057755	Motor/Gearbox 6V
058942	Coin-Cell Battery, PCB
1202678	230 VAC PCB

# APPENDIX/DRAWING LIBRARY

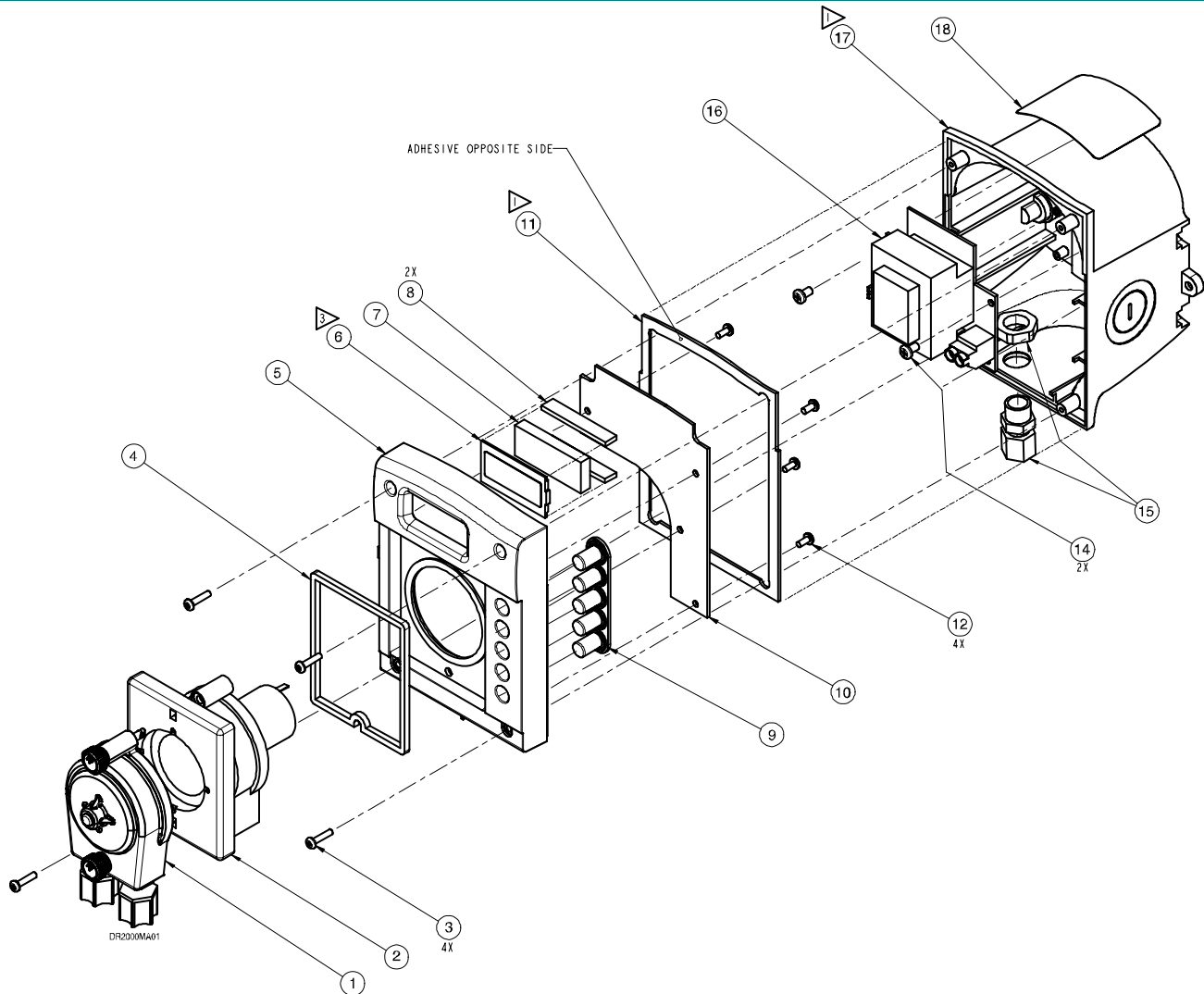

Seq#	Description	Code #
1	SnapHead Pump Cartridge w/Flex Tube	091940
2	Pump Motor Gearbox 6 VDC	057755
3	M3 x 12 mm Panhead Bezel Screws	N/A
4	Pump Gasket	099705
5	Main Bezel	N/A
6	LCD	N/A
7	Foam Spacer	N/A

Seq#	Description	Code #
8	Zebra Strips	N/A
9	Buttons	N/A
10	Main PCB	1202397
11	Bezel Gasket	1202615
12	Main PCB Screws	N/A
16	Power PCB 115 VAC	1202396
16	Power PCB 230 VAC	1202678
17	Bucket	N/A
14	Power PCB Screws	N/A
15	Strain Relief	N/A



**Customer Service**  
 TEL: 831 • 426 • 0882  
 TEL: 800 • 858 • 2382 (toll-free in U.S.A.)  
 FAX: 831 • 423 • 4573  
 FAX: 800 • 221 • 8416  
<http://www.beta-technology.com>

**Global Technical Customer Service**  
**North America:**  
 TEL: 800 • 468 • 4893 (toll-free in U.S.A.)  
 TEL: 262 • 631 • 4461 (international)  
**Europe, Middle East & Africa:**  
 TEL: +1 630 • 513 • 9799

**Asia Pacific:**  
 TEL: +1 86 21-50509900 x 2520  
**Japan:**  
 TEL: +1 090-6506-5140  
**Latin America**  
 TEL: +1 - 541148428270

**Beta Technology is ISO9001 Certified**