

Installation Instructions LP-200012UL Gas Detector

Instructions

Please follow these instructions to connect the LP-200012UL to the NMEA 2000 network via a Maretron SIM100 Switch Indicator Module. The wiring diagram appears in Figure 1 on the reverse side of this page. The diagram shows a connection to channel #1, but connections to other channels are similar.

1. Connect the LP-200012UL power terminals to a 12VDC supply that is independent of the NMEA 2000 network power supply, as shown in Figure 1. Powering the unit separately from the NMEA 2000 network allows the detector to work even when the NMEA 2000 network is powered off.
2. Connect the two alarm contact terminals to a free switch channel on the SIM100. The example in Figure 1 shows the detector connected to switch channel 1, terminals SW1A and SW1B. Note: The detector's protective cover must be removed to perform this function.
3. Use a Maretron DSM250 display (firmware 1.3.5 or higher), the DSM250 Viewing function of Maretron N2KAnalyzer software, or other Maretron display product capable of configuring the SIM100 to set the switch channel mode (indicated as "Channel #x Mode" on the DSM250) for the appropriate channel to the "End of Line Resistor" setting. For this example, you would set "Channel #1 Mode" to "End of Line Resistor".
4. Supply Power to the NMEA 2000 network and to the LP-200012UL and verify that the switch channel indicates an "off" (normal) state using Maretron N2KView software, N2KAnalyzer, or other product capable of displaying switch indicator state.
5. Perform a test using a gas source (cigarette lighter without a flame) applied in front of the LP-200012UL and verify that the switch channel indicates an "on" (alarm) state during the test.
6. Disconnect either of the two alarm wires between the LP-200012UL and the SIM100 and verify that the switch channel indicates an "error" state.
7. Reconnect the alarm wires to the SIM100 and verify that the switch channel indicates an "off" (normal) state.



WARNING: The LP-200012UL is shipped with an 8KΩ end-of-line resistor installed between the alarm contact terminals. Do not remove the resistor; it allows an indication if the wires are inadvertently disconnected between the LP-200012UL and the SIM100.

(continued on reverse)

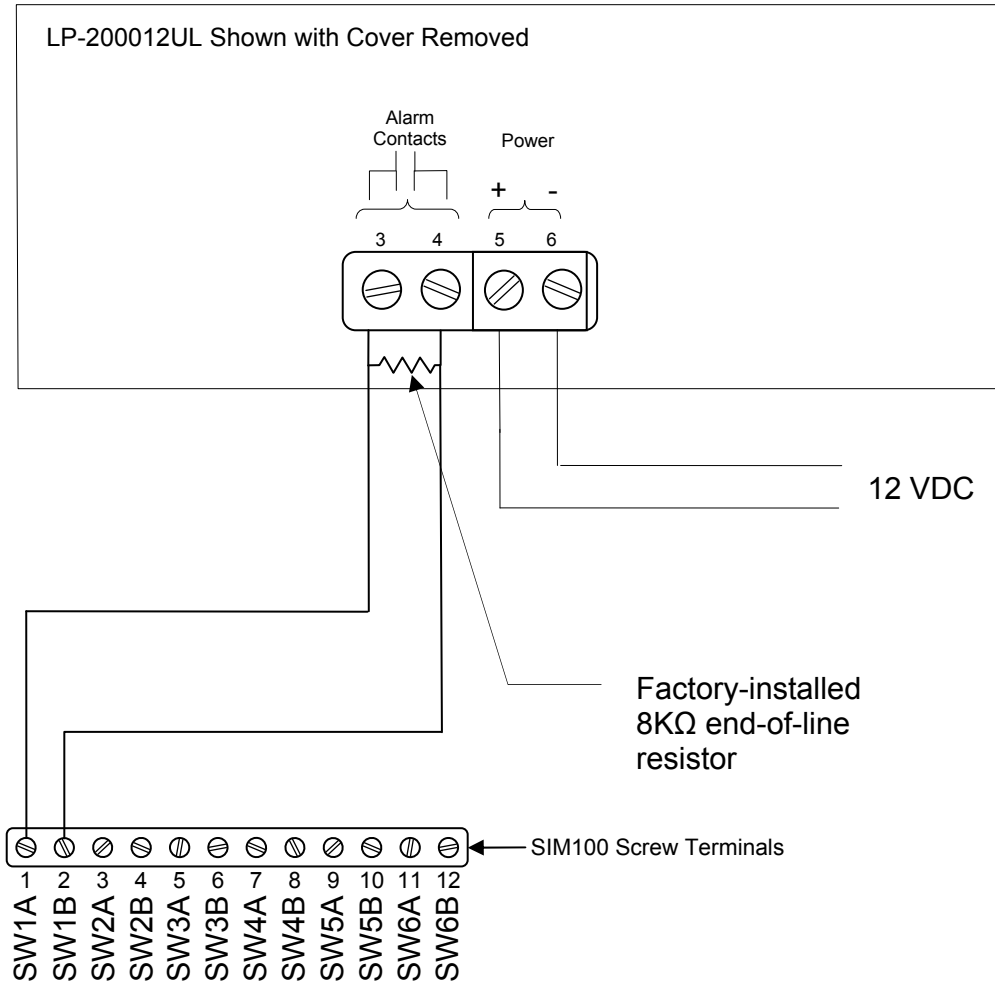

Figure 1 - Wiring Diagram

For installation support, please contact:

Maretron, LLP
9014 N. 23rd Ave #10
Phoenix, AZ 85021-7850
Telephone: (+1) 866-550-9100
E-mail: support@maretron.com
Web: <http://www.maretron.com>