

Sport Climbing Timer

Hengam3 User's Manual

Ordered by KASSA



- An introduction to the device specifications
- Parts
- Technical details of back panel connectors
- Connections and start-up
- General functions
- How to work with menus
- Troubleshooting
- Package contents

Spring 2012

Published by: Technical
Documentation Unit

Version 001; Edition 1.0

[Www.fdpbco.com](http://www.fdpbco.com)



Dear User

Please read the Operation Instructions carefully before attempting to operate the device.

- Please protect this device and its accessories (Sensors, Display Screens, Start Push Button, cables, Audio System, etc.) against moisture and water (such as rain) especially when used outdoors. Exposure to water and moisture may result in serious damages to the device or even electric shock.
- Do your best to preserve and maintain the device in sport centers and avoid from crushing the cables, beating, striking and piercing with sharp objects and also avoid replacing the connectors when connected to the device which is turned on, and protect it against moisture, water and electricity voltage fluctuation.
- This product is made by Iranian engineers who have put in their utmost effort to utilize state-of-the-art technology and highest quality materials so as to optimize its performance. We warmly welcome any user's feedback and recommendations since we believe your comments will certainly help us improve our products.
- All design and manufacturing rights reserved by Fonoun Dadeh Parvari Basamad (FDPB) Company, and all sales rights reserved by Kassa Company. If device is opened or guarantee label removed the company may void warranty system.

An Introduction to the Specifications of Sport Climbing Timer

Due to the increasing in the demand of organizing better sport climbing competitions and the necessity to estimate the competition time more precisely, this device has been manufactured by the effort of Iranian experts to meet the country's need in this regard. More efforts have been done in manufacturing this device which is the third and more developed generation of its previous versions to optimize its functions using the state-of-the-art technology and highest quality materials. The optimization progress involves mechanical to optical (laser) and piezoelectric sensors, software algorithm, packing and mechanical parts, wiring and connectors, display screens. The device has been designed and manufactured with capability of operating in two modes of "Speed" and "Bouldering" for sport climbing competitions.



Parts

Front Panel View

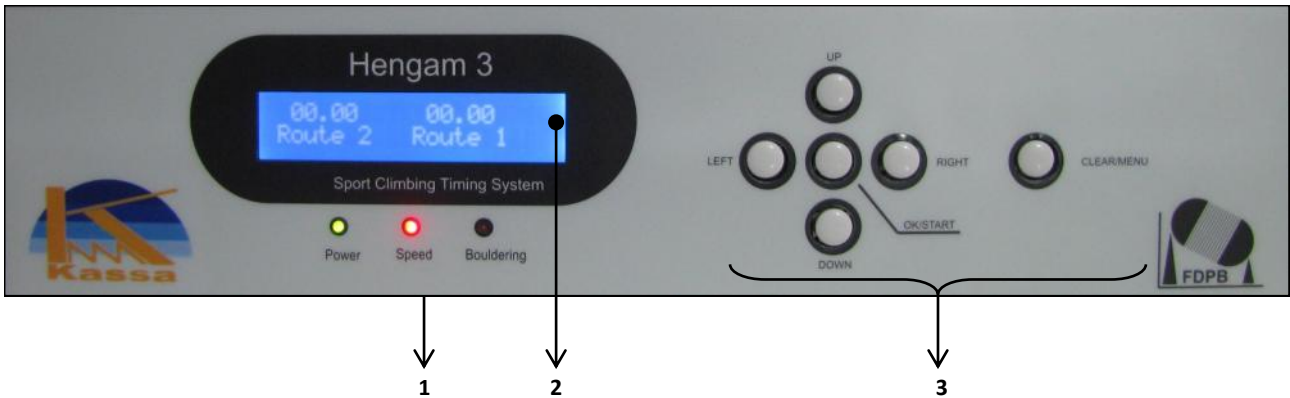

Position	Name	Function
1	LED Indicators: Power indicator: Green Speed indicator: Red	Power indicator turns on when the device is on. Speed indicator turns on when device functions in "SPEED" mode. Bouldering indicator turns on when device functions in "BOULDERING" mode.
2	Character LCD Display Screen	Blue light background – 2 x 16 Character
3	Pushbuttons: UP ,DOWN ,RIGHT, LEFT, OK, START, CLEAR, MENU	The buttons are used for changing the settings, opening the menus, timing and resetting

Technical specifications



GENERAL DATA		
Model: Hengam 3 Sport Climbing System	Power voltage: 85 to 260 voltage AC 47 to 60 Hz	Approximate Dimensions: (Width*Height*Depth) 483*44*300 mm
Weight: ~ 2.5 kg	Software Upgrade Possibility: Yes	Working Temperature: 10 to 50 degree centigrade

Parts

Back - Panel View

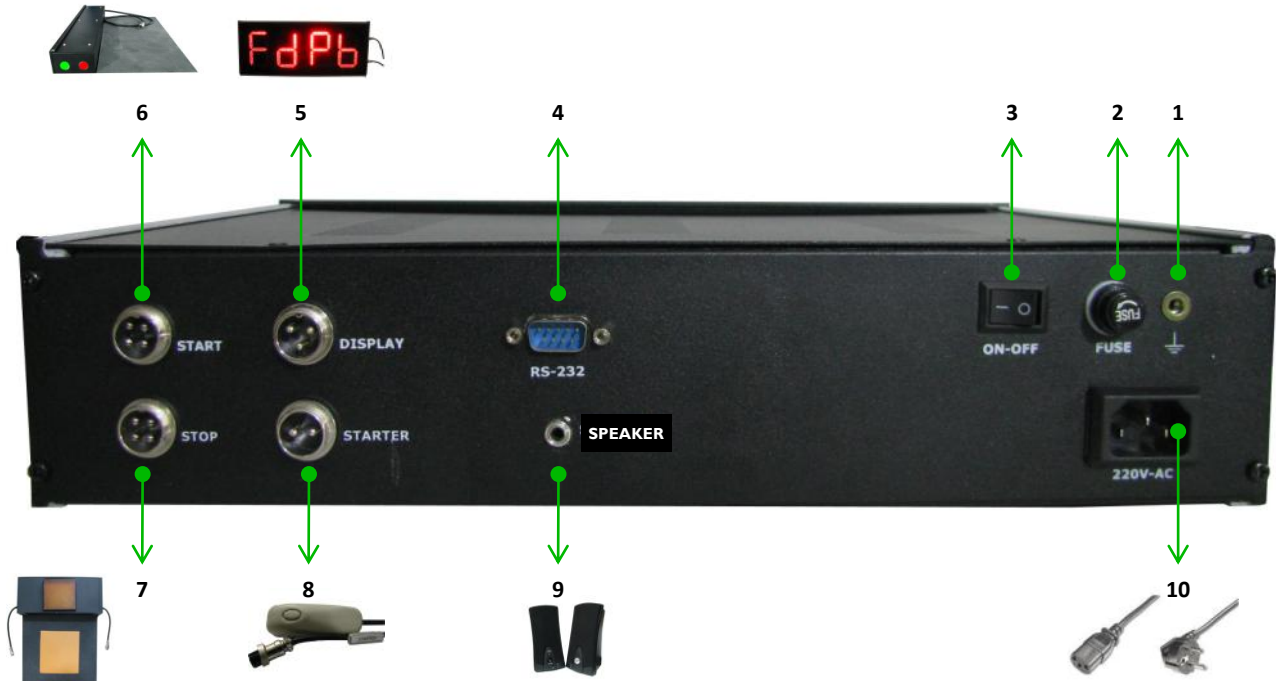

Position	Name	Description
1	GND	Ground Connection Screw
2	FUSE	4 Ampere Glass Fuse
3	ON/OFF KEY	220 Volt Input Power Connector
4	RS-232	Future Development Gate
5	DISPLAY	3- Pin Male Connector to Displays
6	START	4-Pin Male Connector to Foot Sensors
7	STOP	4-Pin Male Connector to Hand Sensors
8	STARTER	2-Pin Male Connector to Start Push Button
9	SPEAKER	Headphone Jack to Audio System (Speaker /Amplifier)
10	220V-AC	Power Connector to 220 V Electricity

Technical Guide for Back-Panel Connectors

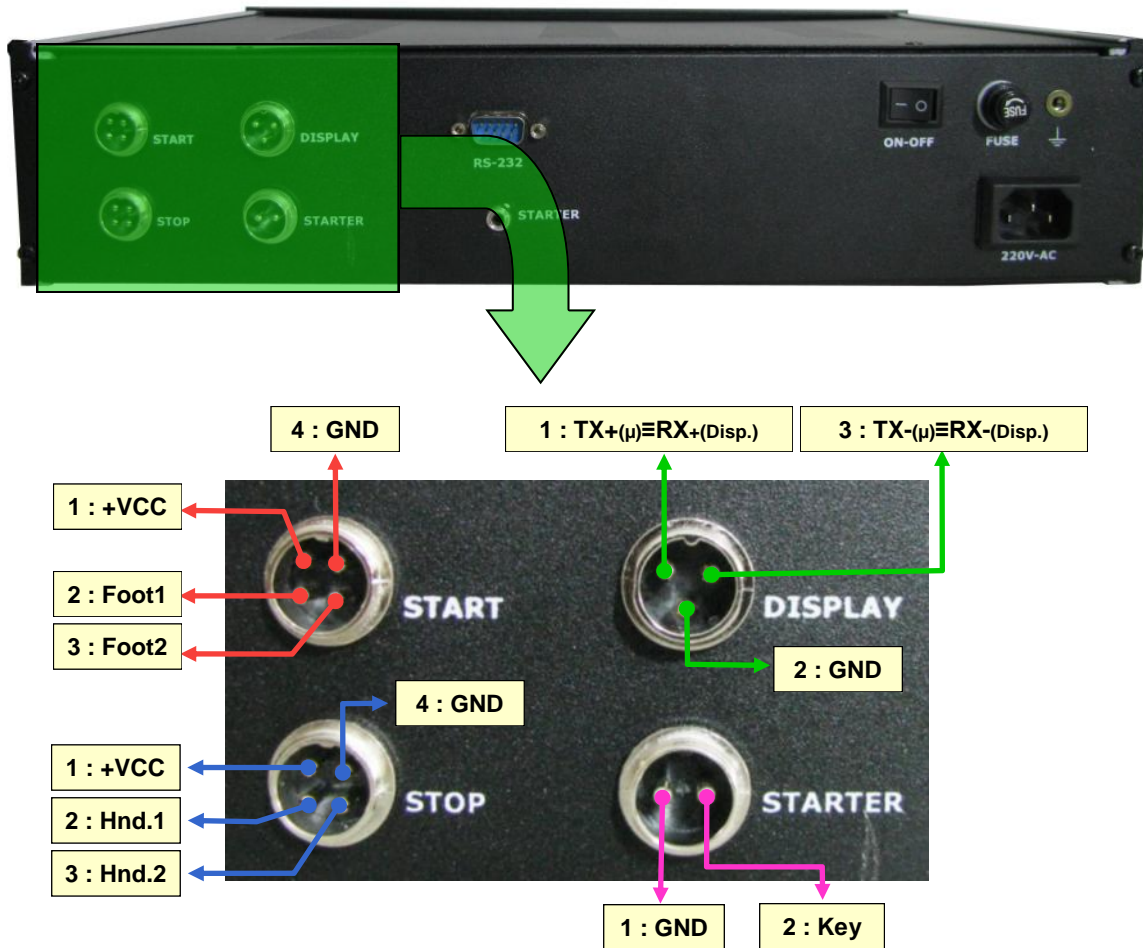

“Hengam 3” Block Diagram

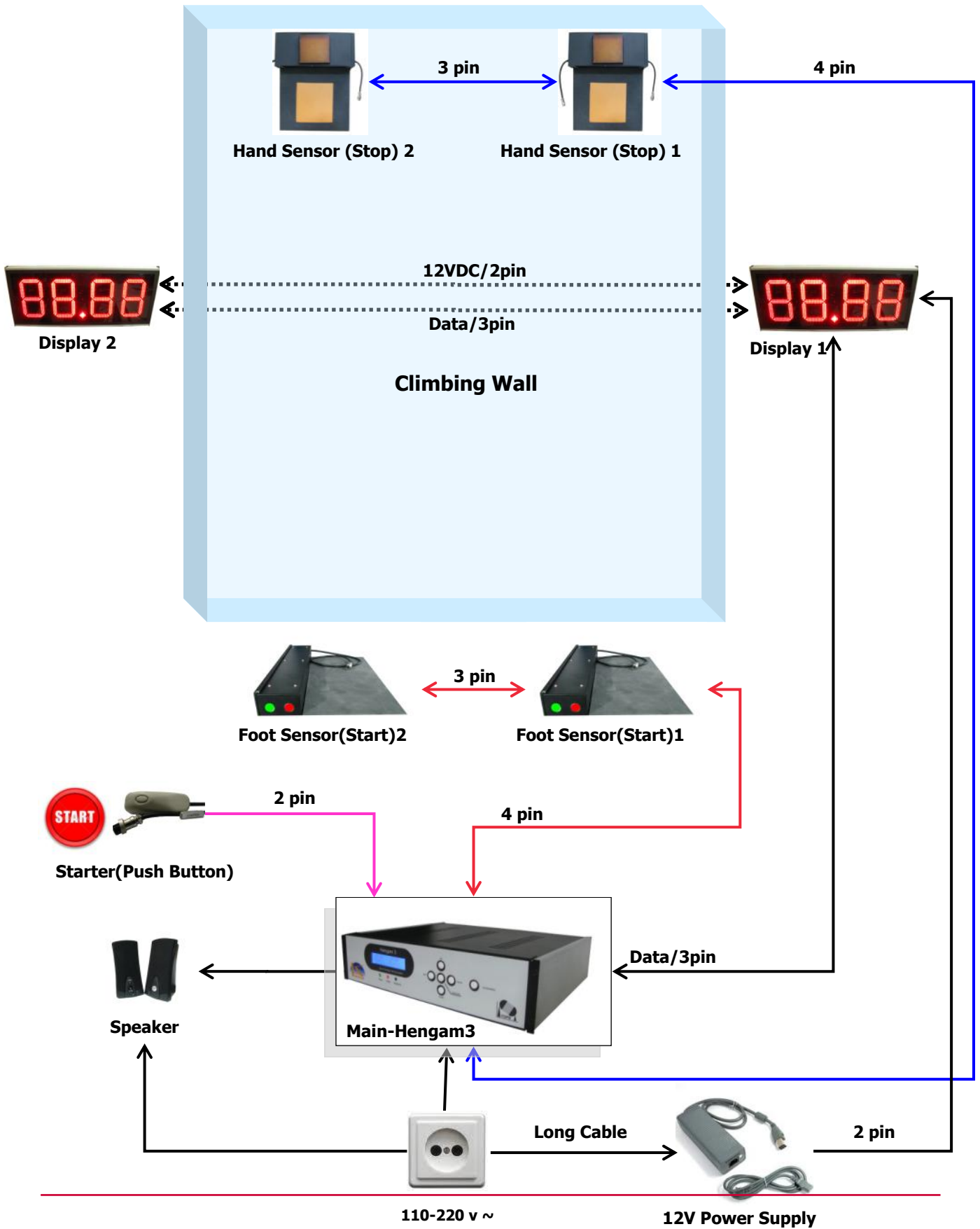

110-220 v ~

12V Power Supply

General Function

This device has been designed and manufactured for two modes of “Speed” and “Bouldering” in sport climbing competitions. The functions of this device in these two modes are explained below.

A. Speed Mode:

A starter asks the climber to stand by the route at start-point and should say “**AT YOUR MARKS**” and then “**Ready**” (as mentioned in the IFSC Rules). Then the climber should hold one foot on foot sensor (Start Panel). By the time the referee pushes the start button a signal is sounded by Speaker for 0.2 second and simultaneously the timing system will be activated. A time sample is recorded from foot sensors when the start key is pushed by the referee for 0.1 second thereafter. In case foot loses contact with sensor within the said time, False Start is displayed. False Start is indicated by a blinking sign of “Err” on Display and is also accompanied by a beeping sound from the Speaker. To stop the False Start you just need to push and hold the Clear/Menu button for 4 seconds.

In case False Start does not occur, the System continues timing. When the athlete touches the colorful part on the Stop Panel with hand, the timing system stops and the whole LED indicators on the panel light up. The time is recorded and will also remain on Display and LED of the main device (Unless the Clear/Menu key on the front panel is pushed and held for 4 seconds to reset the counter).

B. Bouldering Mode:

In bouldering mode, the foot and hand sensors are not used. After setting the trial time on the main unit routes and after pressing the OK/START button, the Audio System sounds the starting signal for five seconds and the timer starts to count down the defined time. The speaker sounds a beeping signal by the time there is only one minute left. When the time is finished the five second sound of Start is heard again which indicates the ending/start time.

Displaying the False Start Message

In case any of the competitors commit a False Start, the Error message is shown on the corresponding display and the alarm sound (beeping sound with half second intervals) is heard.

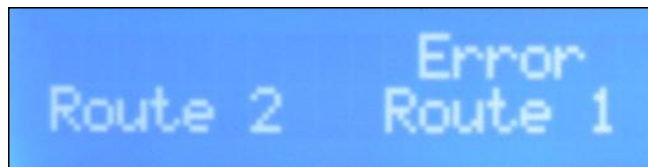

Fig. 4: Route 1 competitor's error

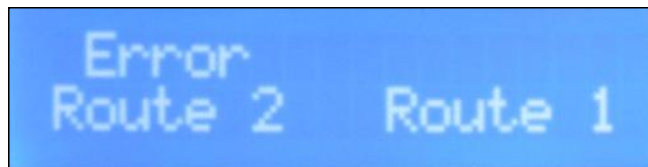

Fig. 5: Route 2 competitor's error

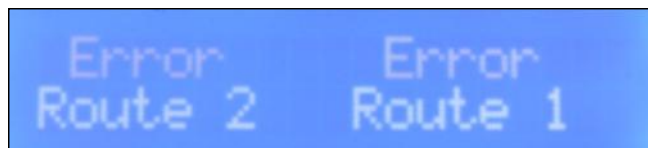

Fig. 6: Both routes competitors' error

To (Reset) the device in case of errors, just push and hold the Clear/Menu button for 4 seconds.

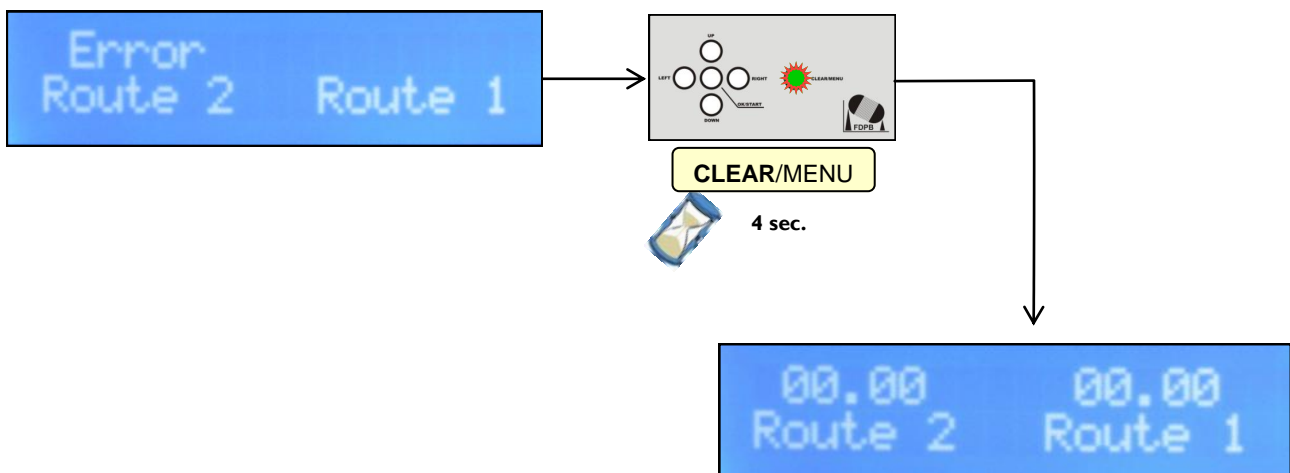

Fig. 7: Holding "Clear" Button to reset

Working with Menus

Using the device is easy and the user can work with it just by two Clear/Menu and OK/Start main buttons and four directional buttons.

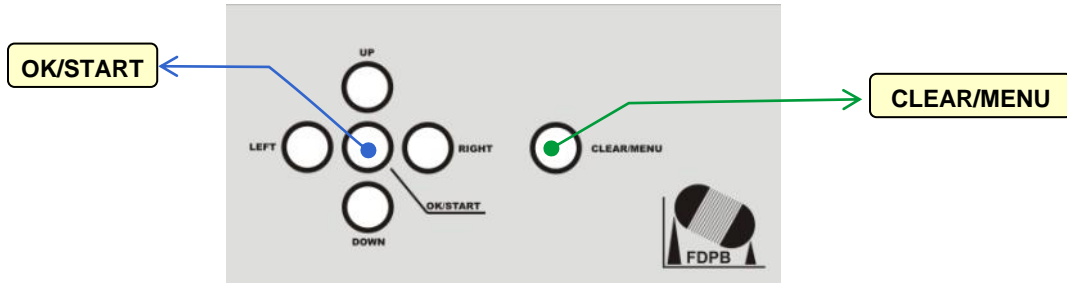

Fig.1

After the device is turned on, the device name and Company' greetings message are displayed.

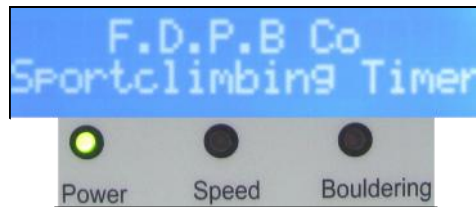

Fig.2

1- Speed Mode

Speed Mode is set by default when the device is turned on (After the corresponding LED displays on the front panel are turned on). After the athlete's foot is suitably put on the foot sensors and after being sure that foot sensor green light is on, the timing can be started by pushing the Start Push Button or the OK/Start button. The timing is started with a 0.2 second sound signal. When any of the corresponding two athletes manually touch the sensors at the top of the wall, the recorded time is indicated on the front panel and the route display.

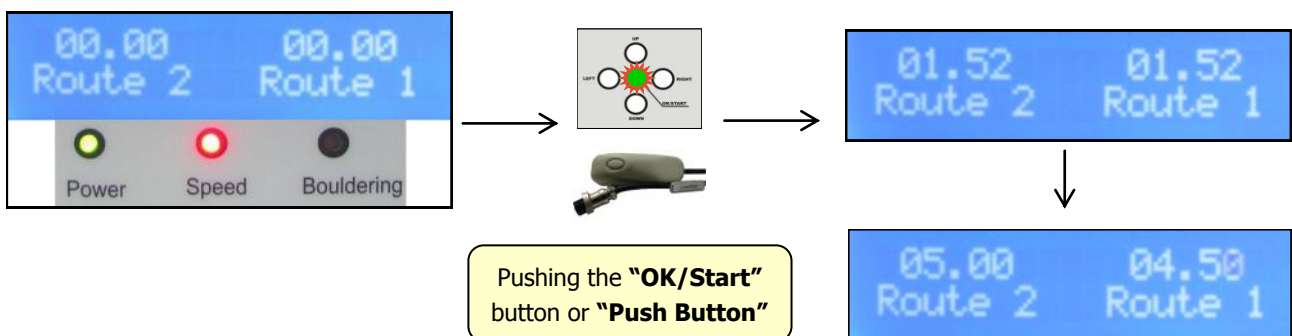

Fig.3

Bouldering Mode

Speed Mode is set by default when the device is turned on. Then the following message appears after pushing Clear/Menu button once (Left picture).

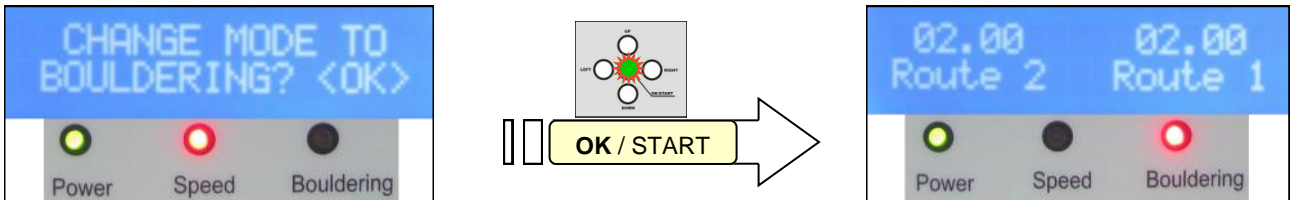

Fig. 8

Now you just need to push OK/Start button once to change the device mode to Bouldering. The mode change is indicated on the



Now, the device is set on bouldering mode and if you push OK/Start button the countdown timing is started for both routes and simultaneously a sound is signaled for 5 seconds that indicates timing is started.

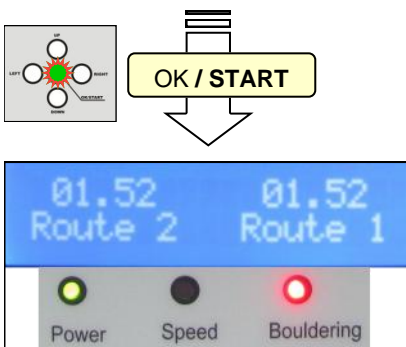

Fig. 9

The default time for bouldering countdown is set to 2 minutes which can be changed in the device menu from 2 to 8 minutes by one-minute steps.

By the following keys combinations you can activate only one route if needed.

Key Equivalent	Combination Equivalent	Route activation
Right (Start)	Up (Reset)	Route 1
Left (Start)	Down (Reset)	Route 2

Bouldering Mode (Continued...)

Timing for both routes by pushing the OK/Start button is possible:

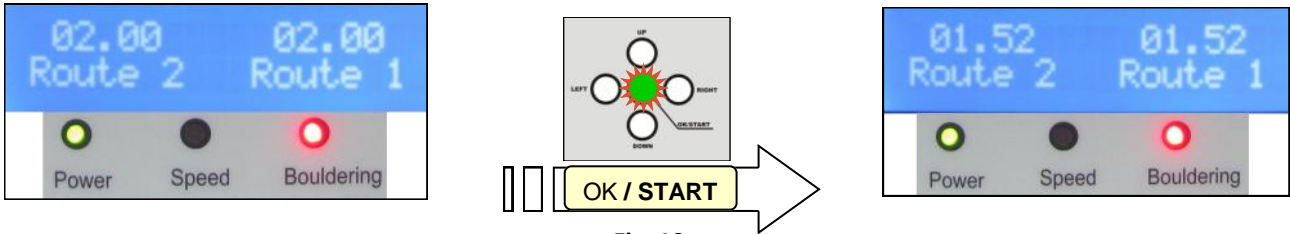

Fig. 10

(Reset)ting the time of both routes by pushing the Clear/Menu button:

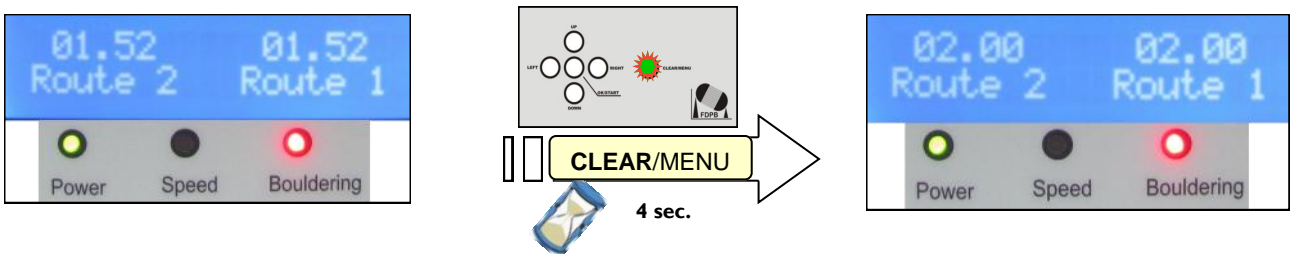

Fig. 11

Timing of route 1 by pushing the Right button:

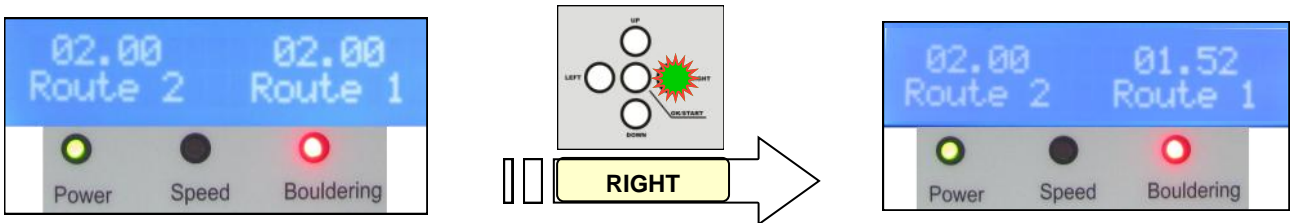

Fig. 12

Time (Reset)ting for route 1 by pushing the Up button:

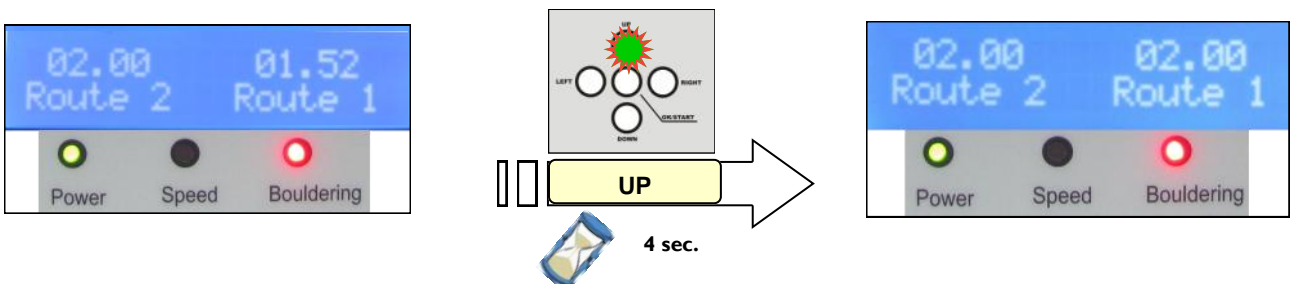

Fig. 13

Bouldering Mode (Continued...)

Timing of route 2 by pushing the Left button:

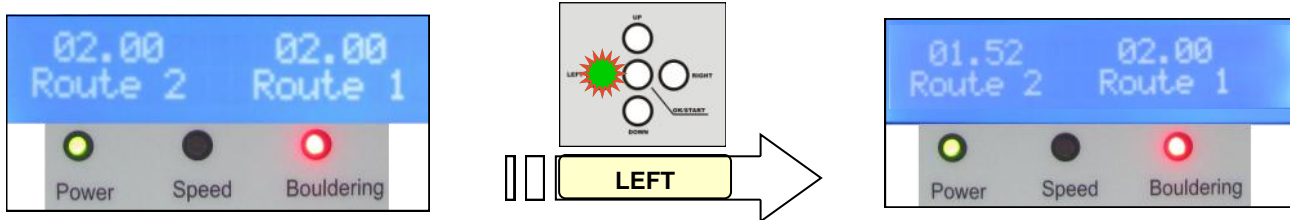

Fig. 14

Time resetting for route 2 by pushing the Down button:

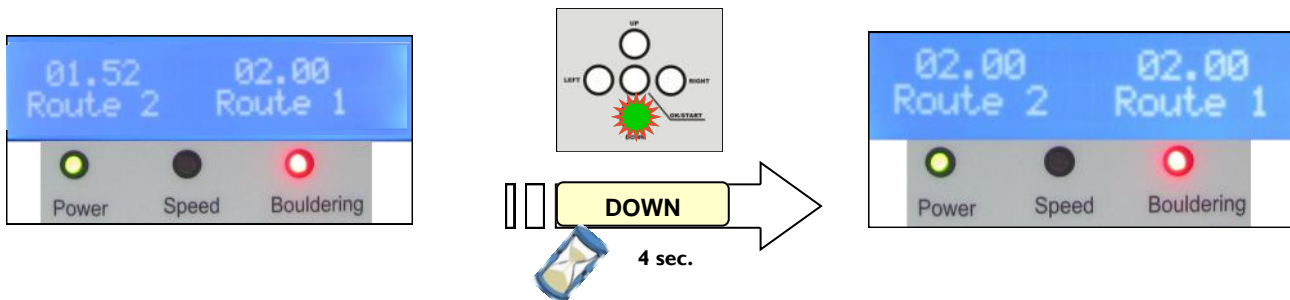

Fig. 15

- In bouldering Mode, whenever there is one minute left, the Speaker sounds an alternative five-second sound while the counter indicates the time counting down. After reaching to zero, the time is then reset to the default time of two minutes automatically.
- You can reset the counter while countdown continued in bouldering mode by pushing and holding the Clear/Menu button for 4 seconds.

Menu for Setting the Bouldering Period

When counter is not counting, you can reach “changing bouldering time” by pressing “Clear/Menu” and the button Down.

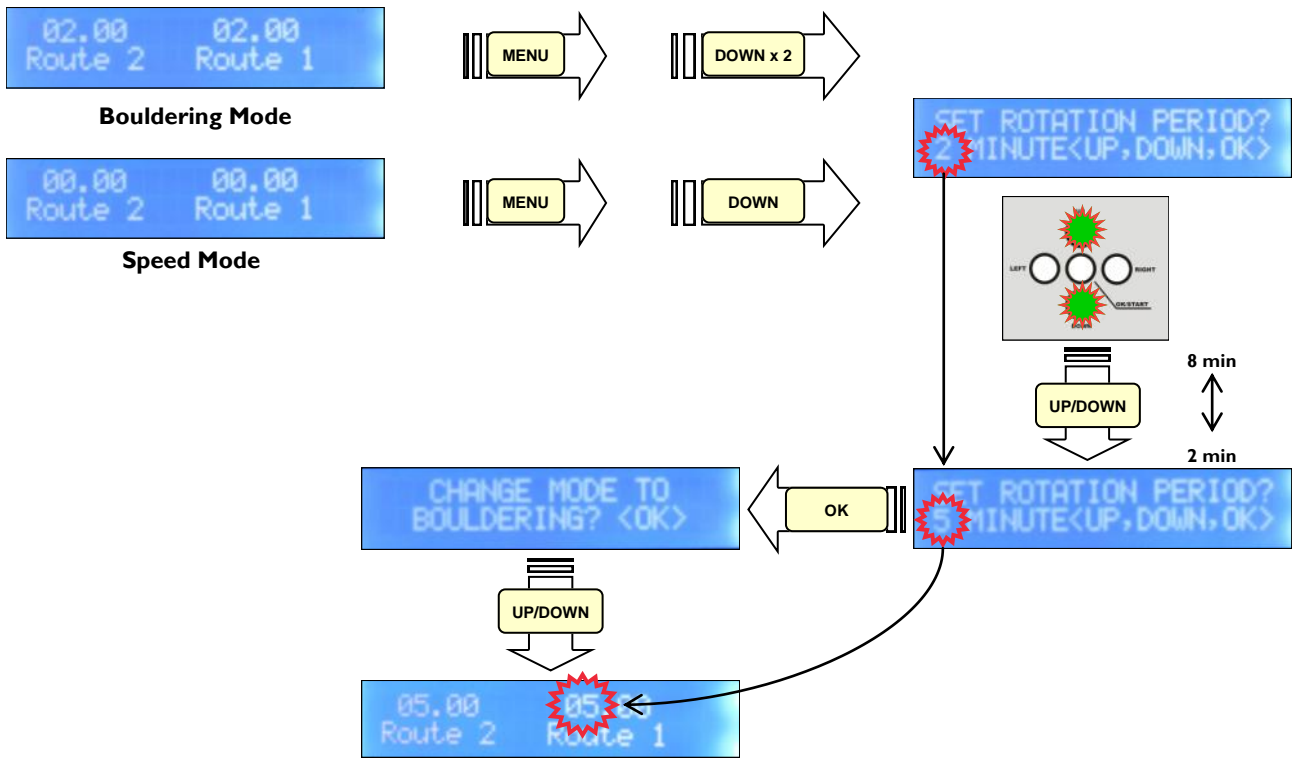

Fig. 16

Light Level Menu

To use the device more conveniently indoors and outdoors, a Light Level setting has been implemented in displays. When the counter is not counting, push Clear/Menu and UP buttons to access LED displays Light Level menu.

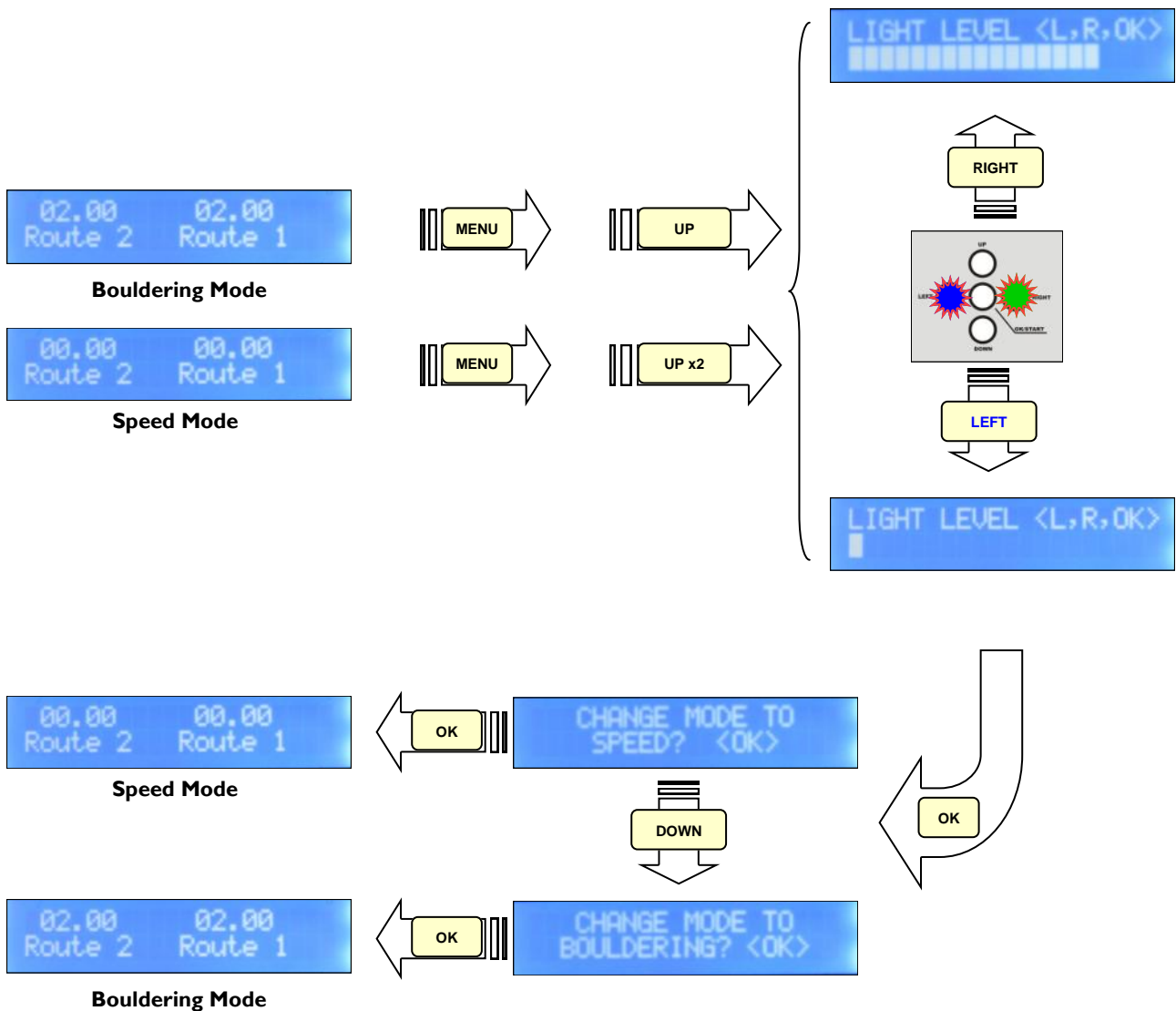

Fig. 17

The light level is saved in device memory after being set so that the light level will be saved after power loss.

Changing the Device Modes (Speed/Bouldering)

Using the Menu, Up, Down and OK buttons you can easily change the modes (Speed/Bouldering).

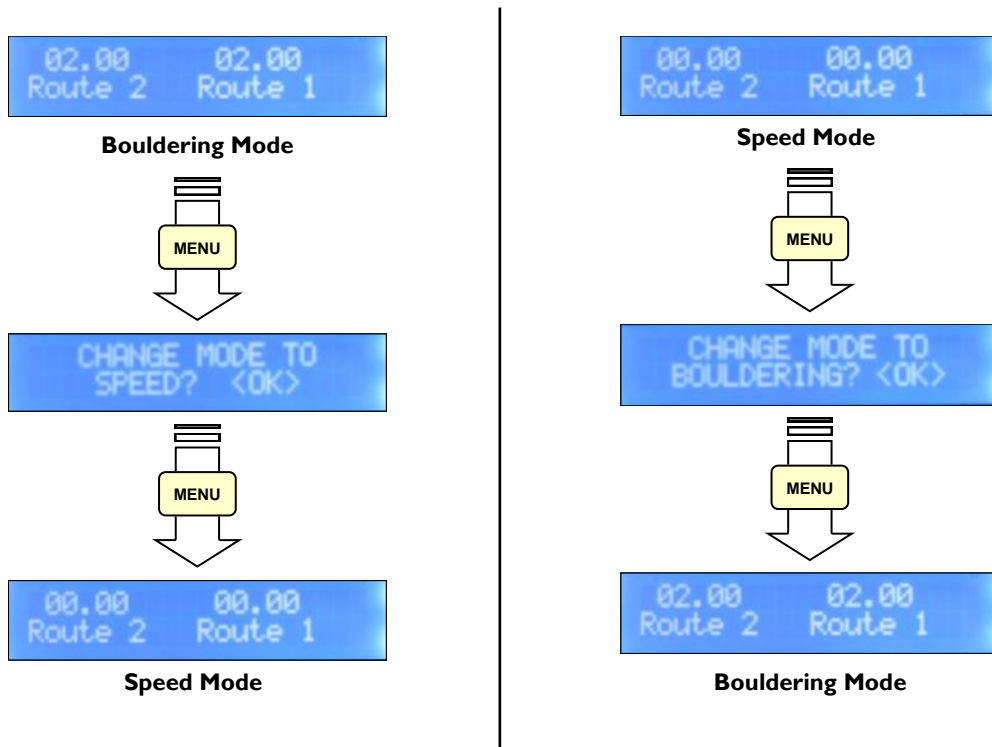

Fig. 18

TROUBLESHOOTING

Problem	Solution
Device does not turn on	Make sure power flows through the mains Check the power supply cable for possible damages Check the existence and functionality of fuse at the device backside Check if the main power button is "ON"
Displays don't turn on	Check the main power supply cable (Display 1) Check the power supply connector (Display 2)
Sensors don't turn on	Check the connector to the main unit (4 pin) (Sensor 1) Check the connector between sensor 1 to 2
False Start message	Check the functionality of sensors by putting a foot on them Check the connecting cables of foot sensors

Accessories & Package Contents:

No.	Item	Quantity	Description
1	Hengam3 Speed Timer Device (Main Unit)	1	(Including the LCD and button panels)
2	Start Push Button	1	Together with the corresponding two-strip cable
3	Stop Panel (Hand sensor)	2	Stop Panel (Activated by hand)
4	Connector of hand sensor 1 to main unit	1	Four-strip cable –25 meters
5	Connector of hand sensor 1 to 2	1	Three-strip cable
6	Start Panel (Foot sensor)	2	
7	Connector of foot sensor 1 (Start Panel) to main unit	1	Four-strip cable – 15 meters
8	Connector of foot sensor 1 to 2	1	Three-strip cable
9	LED Digital display	2	Together with power cable
10	Data connector of display 1 to main unit	1	Four-strip cable – 15 meters
11	Power Supply connector of display 1 to 2	1	Four-strip cable – 15 meters
12	Data Connector of display 1 to 2	1	Three-strip cable
13	Speaker system	1	Two speakers with amplifiers
14	Manual of the Device (The present booklet)	1	
15	220 V Inlet Power Cable of the Device	1	



Maintenance Instructions

The following instructions will ensure longer life for your Sport Climbing Timer:

- Keep the device away from moisture. As mentioned earlier, moisture can cause irreparable damage to the device. If it is to be used in open air, cover the device against rain with equipment such as sunshades.
- Avoid hitting the sensors (Start and Stop Panels).
- In rehearsals, you can remove Displays and Start Push Button, and instead use the screen and buttons on the main device front panel. This will help your device achieve a longer life.
- When the device is working on Bouldering modes, removing Start and Stop Panels(Sensors) is recommended.
- For longer lifetime of rubber foams on Start and Stop Panels, keep away the panels from direct sun light if possible.
- Cables are made of materials with high resistance and quality. However, avoid stretching, crushing or stepping on the cables as that may cause disconnection, signal loss and thus malfunctions in the system. Please put in your utmost care and attention for the maintenance of cables especially their plugs and connectors.

Guarantee Terms

- All parts of Sport Climbing Timer are covered by guarantee services for a one year period from product delivery date. All parts will be repaired for free during guarantee period.
- By the termination of Guarantee Period, users will be charged against repairs.
- Guarantee Policy does not include severe strikes or fire damages.
- Guarantee will be voided if device or any of its parts opened or guarantee label removed.

Sport Climbing Timer– Hengam 3

The Device Check-up Form in Speed Competitions

Competition Number:		Number of Competitors:				Date:		Place:	
Competition Start Time:	Stop Panel (Hand Sensor)		Start Panel (Foot Sensor)		Display		Start Push Button	Speaker	
	Competition End Time:	Right	Left	Right	Left	Right			
Number of Correct Acts (OK)									
Number of Incorrect Acts (Fail)									
Remarks:									
User:		Signature:							

“Hengam 3” Block Diagram

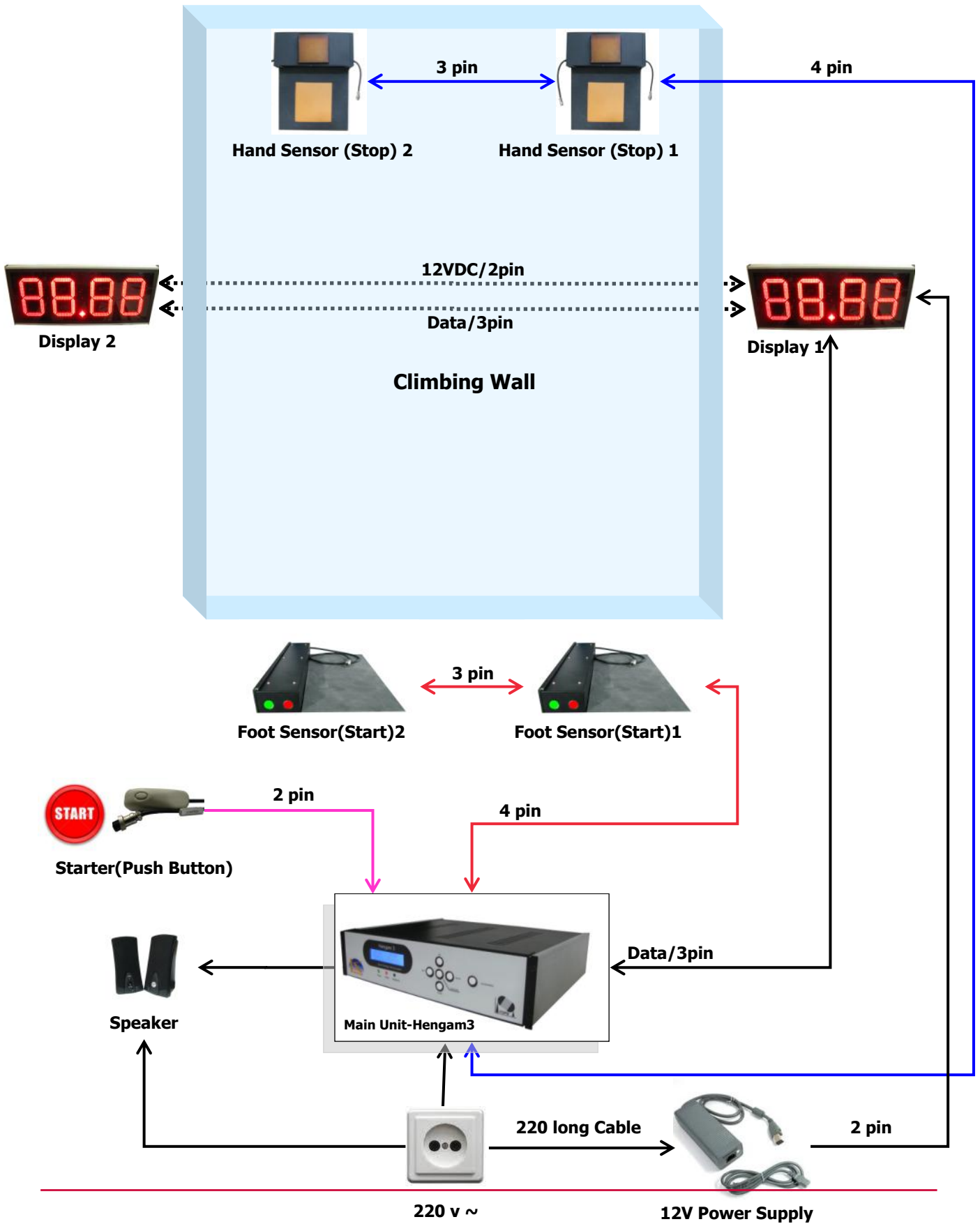



KASSA Mountaineering Co. Ltd.
www.kassa.ir

Unit2, No.27, Razi Complex, Naghdi Alley , Shariati St., Tehran 15637 I.R.IRAN
Tel : +9821 77510463 -4 , Fax : +9821 77622043



FDPB
Fonoun Dadeh Parvari Basamad Ltd.
www.fdpbco.com

Address: Unit 3 No. 2, Sarv Alley, Tohid Avenue, Tohid Sq., Tehran
Tel: (+9821) 66572534 Fax: (+9821) 66934265

