

Kramer Electronics, Ltd.



USER MANUAL

Model:

VS-2DVA

2x1 DVI / XGA / Audio Switcher

Contents

1	Introduction	1
2	Getting Started	1
3	Overview	1
4	Your VS-2DVA 2x1 DVI / XGA / Audio Switcher	2
5	Connecting the VS-2DVA 2x1 DVI / XGA / Audio Switcher	4
5.1	Connecting the Contact Closure Remote Control PINS	6
6	Operating the VS-2DVA 2x1 DVI / XGA / Audio Switcher	7
6.1	Switching DVI and XGA Signals Separately	7
6.2	Switching DVI and XGA Signals Together (Ganged)	7
7	Technical Specifications	8

Figures

Figure 1:	VS-2DVA 2x1 DVI / XGA / Audio Switcher	2
Figure 2:	Connecting the VS-2DVA 2x1 DVI / XGA / Audio Switcher	5
Figure 3:	Connecting the Contact Closure Remote Control PINS	6
Figure 4:	Initial Status of the SELECTOR Buttons	7

Tables

Table 1:	Front Panel VS-2DVA 2x1 DVI / XGA / Audio Switcher Features	3
Table 2:	Rear Panel VS-2DVA 2x1 DVI / XGA / Audio Switcher Features	3
Table 3:	Technical Specifications of the VS-2DVA 2x1 DVI / XGA / Audio Switcher	8

1 Introduction

Welcome to Kramer Electronics (since 1981): a world of unique, creative and affordable solutions to the infinite range of problems that confront the video, audio and presentation professional on a daily basis. In recent years, we have redesigned and upgraded most of our line, making the best even better! Our 350-plus different models now appear in 8 Groups¹, which are clearly defined by function. Congratulations on purchasing your **VS-2DVA 2x1 DVI / XGA² / Audio Switcher**. This product is ideal for:

- Presentation and multimedia applications
- Preview and monitoring graphics and audio signals

The package includes the following items:

- **VS-2DVA 2x1 DVI / XGA² / Audio Switcher**
- Power adapter (12V DC Input)
- This user manual³

2 Getting Started

We recommend that you:

- Unpack the equipment carefully and save the original box and packaging materials for possible future shipment
- Review the contents of this user manual
- Use Kramer high performance high resolution cables⁴

3 Overview

The **VS-2DVA** is an all-in-one 2x1 switcher for DVI, XGA/UXGA², and unbalanced audio signals. In particular, the **VS-2DVA**:

- Equalizes and reclocks the DVI input, effectively reconstructing and retransmitting the DVI signal
- Has an XGA/UXGA¹ video bandwidth of 350MHz, that ensures

1 GROUP 1: Distribution Amplifiers; GROUP 2: Video and Audio Switchers, Matrix Switchers and Controllers; GROUP 3: Video, Audio, VGA/XGA Processors; GROUP 4: Interfaces and Sync Processors; GROUP 5: Twisted Pair Interfaces; GROUP 6: Accessories and Rack Adapters; GROUP 7: Scan Converters and Sealers; and GROUP 8: Cables and Connectors

2 Handles all known computer video resolutions (VGA to UXGA)

3 Download up-to-date Kramer user manuals from the Internet at this URL: <http://www.kramerelectronics.com/manuals.html>

4 The complete list of Kramer cables is on our Web site at <http://www.kramerelectronics.com> (click "Cables and Connectors" in the Products section)

transparent operation is achieved at the highest resolutions

- Comes with contact closure remote control for forced operation
- Is housed in a half 19" rack size and is 12VDC fed

In addition, with the high quality **VS-2DVA**, both:

- DVI inputs have their own corresponding audio inputs, and the DVI output has its own audio output
- XGA/UXGA¹ inputs have their own corresponding audio inputs, and the XGA/UXGA output has its own audio output
- DVI and XGA/UXGA¹ signals can be switched separately or ganged (switched together)

Achieving the best performance means:

- Connecting only good quality connection cables, thus avoiding interference, deterioration in signal quality due to poor matching, and elevated noise levels (often associated with low quality cables)
- Avoiding interference from neighboring electrical appliances and positioning your **VS-2DVA** away from moisture, excessive sunlight and dust

4 Your VS-2DVA 2x1 DVI / XGA / Audio Switcher

Figure 1, Table 1 and Table 2 define the **VS-2DVA**:

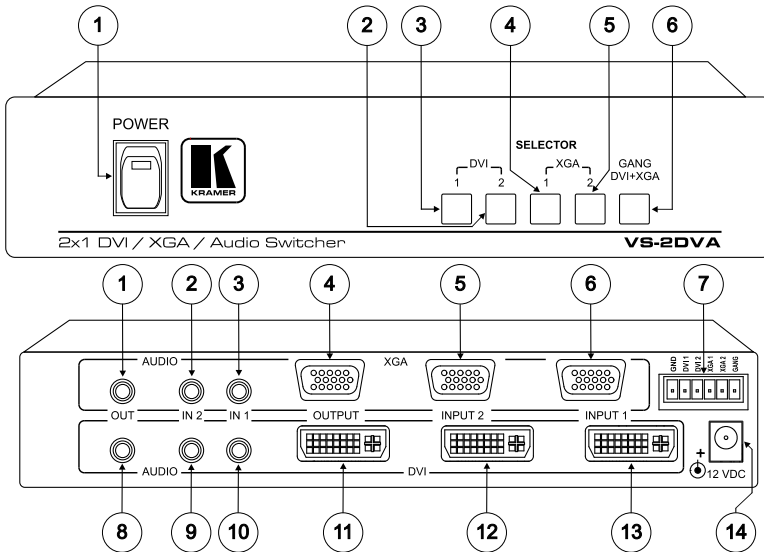

Figure 1: VS-2DVA 2x1 DVI / XGA / Audio Switcher

¹ Handles all known computer video resolutions (VGA to UXGA)

Table 1: Front Panel VS-2DVA 2x1 DVI / XGA¹ / Audio Switcher Features

#	Feature	Function	
1	POWER Switch	Illuminated switch for turning the unit ON or OFF	
2	SELECTOR Buttons	DVI 2	Press to select the DVI source at input 2
3		DVI 1	Press to select the DVI source at input 1
4		XGA ¹ 1	Press to select the XGA ¹ source at input 1
5		XGA ¹ 2	Press to select the XGA ¹ source at input 2
6		GANG DVI+XGA ¹	Press to toggle between switching the DVI and the XGA ¹ signals in one action or separately

Table 2: Rear Panel VS-2DVA 2x1 DVI / XGA¹ / Audio Switcher Features

#	Feature	Function
1	AUDIO OUT (XGA ¹) 3.5mm Mini Jack	Connects to the unbalanced stereo audio acceptor that corresponds to the XGA ¹ output
2	AUDIO IN 2 (XGA ¹) 3.5mm Mini Jack	Connects to the unbalanced stereo audio source that corresponds to the XGA ¹ source 2
3	AUDIO IN 1 (XGA ¹) 3.5mm Mini Jack	Connects to the unbalanced stereo audio source that corresponds to the XGA ¹ source 1
4	XGA ¹ OUTPUT HD15F Connector	Connects to the XGA ¹ acceptor
5	XGA ¹ INPUT 2 HD15F Connector	Connects to the XGA ¹ source 2
6	XGA ¹ INPUT 1 HD15F Connector	Connects to the XGA ¹ source 1
7	REMOTE Terminal Block Connector	Connects to dry contact switches
8	AUDIO (DVI) 3.5mm Mini Jack	Connects to the unbalanced stereo audio acceptor that corresponds to the DVI output
9	AUDIO IN 2 (DVI) 3.5mm Mini Jack	Connects to the unbalanced stereo audio source that corresponds to the DVI source 2
10	AUDIO IN 1 (DVI) 3.5mm Mini Jack	Connects to the unbalanced stereo audio source that corresponds to the DVI source 1
11	DVI OUTPUT Connector	Connects to the DVI acceptor
12	DVI INPUT 2 Connector ²	Connects to the DVI source 2
13	DVI INPUT 1 Connector ²	Connects to the DVI source 1
14	12V DC	+12V DC connector for powering the unit

1 Handles all known computer video resolutions (VGA to UXGA)

2 Does not support High bandwidth Digital Content Protection (HDCP)

5 Connecting the VS-2DVA 2x1 DVI / XGA / Audio Switcher

To connect your **VS-2DVA 2x1 DVI / XGA / Audio Switcher**, as the example in Figure 2 illustrates, do the following¹:

1. Connect up to 2 XGA/UXGA sources to the 2 HD15F input connectors, and connect up to 2 unbalanced stereo audio sources to the 2 corresponding AUDIO input 3.5mm mini jacks, as follows:
 - Connect the XGA source 1 (for example, a laptop's digital graphics card) to the INPUT 1 XGA HD15F connector, and its audio to the IN 1 3.5mm mini jack, for example, using a Kramer C-GMA/GMA cable (VGA HD15M +Audio jack to VGA HD15M +Audio jack)²
 - Connect the XGA source 2 (for example, a PC) to the INPUT 2 XGA HD15F connector and its audio to the IN 2 3.5mm mini jack, using separate cables (as illustrated in Figure 2) or a Kramer C-GMA/GMA cable²
2. Connect up to 2 DVI (that is, DVI-D) sources (for example, computers) to the 2 DVI-I input connectors, INPUT 1 and INPUT 2, and connect up to 2 unbalanced stereo audio sources to the 2 corresponding AUDIO input 3.5mm mini jacks.
3. Connect the XGA HD15F output connector³ to the XGA acceptor (for example, a monitor) and connect the corresponding AUDIO output 3.5mm mini jack to the unbalanced stereo audio acceptor (for example, an amplifier and a pair of speakers).
4. Connect the DVI output connector³ to the DVI acceptor (for example, a projector) and connect the corresponding AUDIO output 3.5mm mini jack of the **VS-2DVA** to the INPUT 1 3.5mm mini jack of the **903 Personal Stereo Amplifier**.
5. Connect⁴ the contact closure remote control PINS (optional), see section 5.1.
6. Connect⁴ the 12V DC power adapter (wall transformer) to the 12V DC socket and connect the transformer to the mains electricity.

1 Switch OFF the power on each device before connecting it to your VS-2DVA. After powering up your VS-2DVA, switch on the power on each device

2 Not supplied. The complete list of Kramer cables is on our Web site at <http://www.kramerelectronics.com> (click "Cables and Connectors" in the Products section)

3 You do not have to connect both outputs. For example, if you only want to switch DVI, connect only that output of the VS-2DVA, and leave the XGA output unconnected

4 The connection is not illustrated in Figure 2

Connecting the VS-2DVA 2x1 DVI / XGA / Audio Switcher

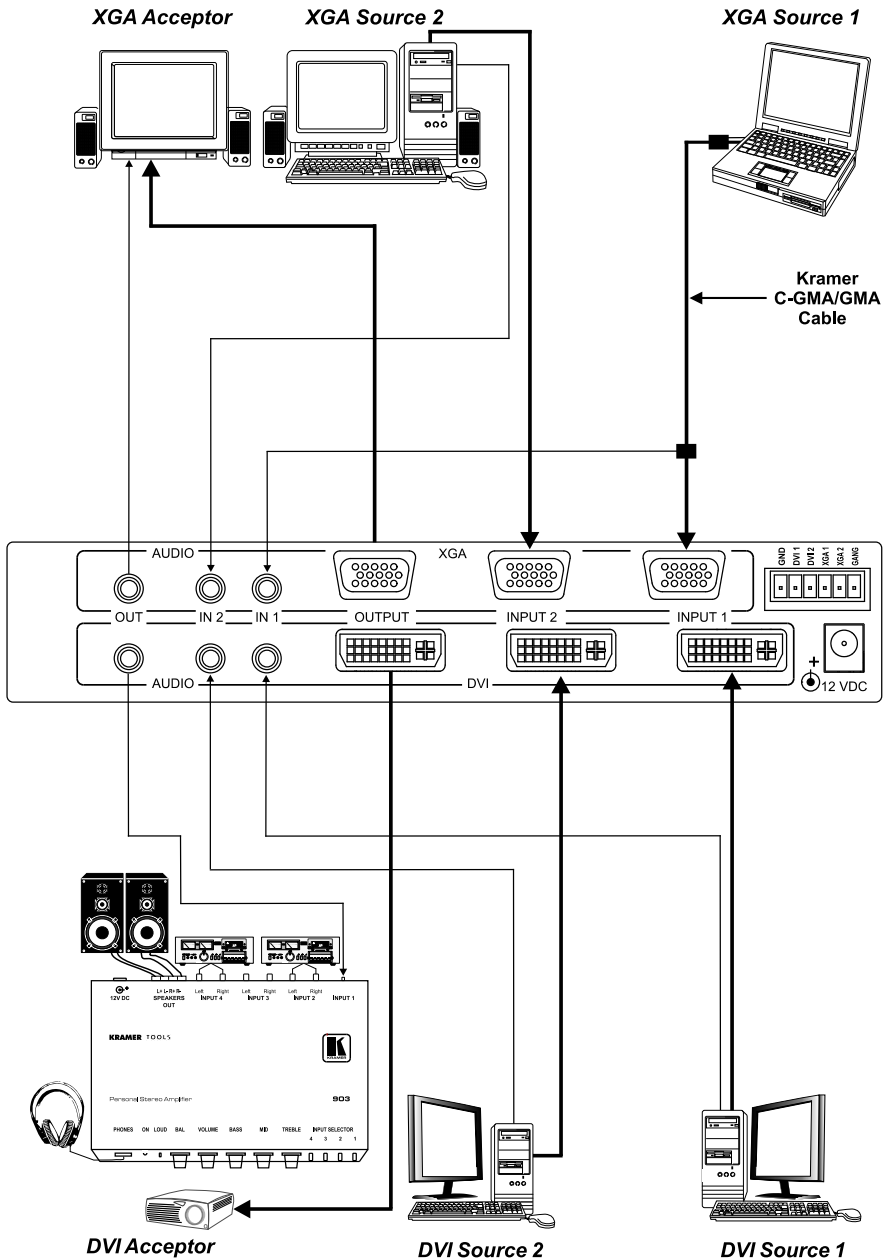

Figure 2: Connecting the VS-2DVA 2x1 DVI / XGA / Audio Switcher

5.1 Connecting the Contact Closure Remote Control PINS

You can use the contact closure remote control PINS to:

- Route an input, and its corresponding unbalanced stereo audio output, by remote control
- Toggle the GANG selection, that is, switching the DVI and XGA inputs in a combined action or separately. (By default, at the moment that the GANG function is selected, the DVI selection takes priority over the XGA selection), see section 6.2

To do so, **momentarily** connect the appropriate¹ REMOTE terminal block connector PIN to the REMOTE terminal block connector Ground PIN (see the illustration in Figure 3). The appropriate front panel push button(s) illuminate(s) as the selected input(s) routes to the appropriate output(s).

DO NOT:

- Interconnect PIN DVI 1, PIN DVI 2, PIN XGA 1, PIN XGA 2, or PIN GANG
- Connect more than one PIN to the Ground PIN at the same time

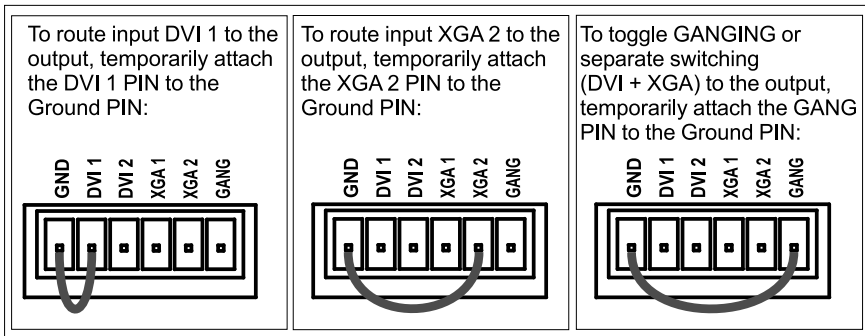

Figure 3: Connecting the Contact Closure Remote Control PINS

¹ To route DVI Input 1, connect PIN DVI 1 to the Ground PIN; to route DVI Input 2, connect PIN DVI 2 to the Ground PIN. To route XGA Input 1, connect PIN XGA 1 to the Ground PIN; to route XGA Input 2, connect PIN XGA 2 to the Ground PIN. To route the GANG, connect PIN GANG to the Ground PIN

6 Operating the VS-2DVA 2x1 DVI / XGA / Audio Switcher

The **VS-2DVA** automatically selects DVI INPUT 1 and XGA INPUT 1 when power to the **VS-2DVA** is turned ON (see Figure 4):

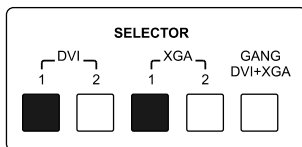

Figure 4: Initial Status of the SELECTOR Buttons

You can switch one of the two DVI inputs¹ to the corresponding DVI output², and one of the two XGA inputs¹ to the corresponding XGA output², either:

- Separately, see section 6.1
- Together (Ganged), see section 6.2

6.1 Switching DVI and XGA Signals Separately

To switch a DVI input and an XGA input in two separate actions:

- If the GANG (DVI + XGA) button is lit, press to toggle for separate selection. The button is now not illuminated
- Press one of the two DVI Selector buttons

The pressed button illuminates, indicating selection and outputting of that video and audio source

- Press one of the two XGA Selector buttons

The pressed button illuminates, indicating selection and outputting of that video and audio source

6.2 Switching DVI and XGA Signals Together (Ganged)

To switch a DVI input and an XGA input in a combined action:

- If the GANG (DVI + XGA) button is not lit, then press to toggle for GANGED operation

The button is now illuminated

- Press one of the two DVI or XGA SELECTOR buttons

The pressed button illuminates, together with the XGA or DVI SELECTOR button corresponding to the same input number, indicating selection and outputting of those video and audio sources

¹ With its unbalanced stereo audio input

² Together with the unbalanced stereo audio output

7 Technical Specifications

Table 3 includes the technical specifications:

Table 3: Technical Specifications¹ of the VS-2DVA 2x1 DVI / XGA / Audio Switcher

INPUTS:	2 XGA/UXGA ² on HD15F connectors; with corresponding 2 unbalanced stereo audio 14dBm/50k on 3.5mm mini jacks 2 DVI ³ , 1.2Vpp on DVI Molex 24pin female connectors; DDC signal 5Vpp (TTL); with corresponding 2 unbalanced stereo audio 14dBm/50k on 3.5mm mini jacks	
OUTPUTS:	1 XGA/UXGA ² on an HD15F connector; with corresponding 1 unbalanced stereo audio 14dBm/50k on a 3.5mm mini jack 1 DVI ³ , 1.2Vpp on a DVI Molex 24pin female connector; DDC signal 5Vpp (TTL); with corresponding 1 unbalanced stereo audio 14dBm/50k on a 3.5mm mini jack	
MAX. OUTPUT LEVEL:	VIDEO: 1.6Vpp	AUDIO: 14.2dBm
BANDWIDTH (-3dB):	VIDEO: 340MHz, Fully Loaded	AUDIO: >100kHz
DIFF. GAIN:	0.03%	
DIFF. PHASE:	0.02 deg	
K-FACTOR:	<0.05%	
S/N RATIO:	VIDEO: 74.2dB	AUDIO: 87.3dB
CROSSTALK (all hostile):	VIDEO: -55.9dB	AUDIO: -59dB
COUPLING:	VIDEO: DC	AUDIO: DC
AUDIO THD + NOISE:	0.019%	
AUDIO 2nd HARMONIC:	0.003%	
POWER SOURCE:	12 VDC 280mA	
DIMENSIONS:	22cm x 18cm x 4.5cm (8.7" x 7" x 1.7") W, D, H.	
WEIGHT:	1.3 kg (2.9 lbs.) approx.	
ACCESSORIES:	Power supply (12V, 500mA)	
OPTIONS:	RK-80 19" rack kit	

¹ Specifications are subject to change without notice

² Handles all known computer video resolutions (VGA to UXGA)

³ On a DVI-I connector. Note that only the digital signal (DVI-D) is available on the DVI connector

LIMITED WARRANTY

Kramer Electronics (hereafter *Kramer*) warrants this product free from defects in material and workmanship under the following terms.

HOW LONG IS THE WARRANTY

Labor and parts are warranted for three years from the date of the first customer purchase.

WHO IS PROTECTED?

Only the first purchase customer may enforce this warranty.

WHAT IS COVERED AND WHAT IS NOT COVERED

Except as below, this warranty covers all defects in material or workmanship in this product. The following are not covered by the warranty:

1. Any product which is not distributed by Kramer, or which is not purchased from an authorized Kramer dealer. If you are uncertain as to whether a dealer is authorized, please contact Kramer at one of the agents listed in the web site www.kramerelectronics.com.
2. Any product, on which the serial number has been defaced, modified or removed.
3. Damage, deterioration or malfunction resulting from:
 - i) Accident, misuse, abuse, neglect, fire, water, lightning or other acts of nature
 - ii) Product modification, or failure to follow instructions supplied with the product
 - iii) Repair or attempted repair by anyone not authorized by Kramer
 - iv) Any shipment of the product (claims must be presented to the carrier)
 - v) Removal or installation of the product
 - vi) Any other cause, which does not relate to a product defect
 - vii) Cartons, equipment enclosures, cables or accessories used in conjunction with the product

WHAT WE WILL PAY FOR AND WHAT WE WILL NOT PAY FOR

We will pay labor and material expenses for covered items. We will not pay for the following:

1. Removal or installations charges.
2. Costs of initial technical adjustments (set-up), including adjustment of user controls or programming. These costs are the responsibility of the Kramer dealer from whom the product was purchased.
3. Shipping charges.

HOW YOU CAN GET WARRANTY SERVICE

1. To obtain service on you product, you must take or ship it prepaid to any authorized Kramer service center.
2. Whenever warranty service is required, the original dated invoice (or a copy) must be presented as proof of warranty coverage, and should be included in any shipment of the product. Please also include in any mailing a contact name, company, address, and a description of the problem(s).
3. For the name of the nearest Kramer authorized service center, consult your authorized dealer.

LIMITATION OF IMPLIED WARRANTIES

All implied warranties, including warranties of merchantability and fitness for a particular purpose, are limited in duration to the length of this warranty.

EXCLUSION OF DAMAGES

The liability of Kramer for any effective products is limited to the repair or replacement of the product at our option. Kramer shall not be liable for:

1. Damage to other property caused by defects in this product, damages based upon inconvenience, loss of use of the product, loss of time, commercial loss; or:
2. Any other damages, whether incidental, consequential or otherwise. Some countries may not allow limitations on how long an implied warranty lasts and/or do not allow the exclusion or limitation of incidental or consequential damages, so the above limitations and exclusions may not apply to you.

This warranty gives you specific legal rights, and you may also have other rights, which vary from place to place.

NOTE: All products returned to Kramer for service must have prior approval. This may be obtained from your dealer. This equipment has been tested to determine compliance with the requirements of:

EN-50081:	"Electromagnetic compatibility (EMC); generic emission standard. Part 1: Residential, commercial and light industry"
EN-50082:	"Electromagnetic compatibility (EMC) generic immunity standard. Part 1: Residential, commercial and light industry environment".
CFR-47:	FCC Rules and Regulations: Part 15: "Radio frequency devices Subpart B – Unintentional radiators"

CAUTION!

- ☒ Servicing the machines can only be done by an authorized Kramer technician. Any user who makes changes or modifications to the unit without the expressed approval of the manufacturer will void user authority to operate the equipment.
- ☒ Use the supplied DC power supply to feed power to the machine.
- ☒ Please use recommended interconnection cables to connect the machine to other components.





For the latest information on our products and a list of Kramer distributors, visit our Web site: www.kramerelectronics.com.

**Updates to this user manual may be found at
<http://www.kramerelectronics.com/manuals.html>.**

We welcome your questions, comments and feedback.



Kramer Electronics, Ltd.

Web site: www.kramerelectronics.com

E-mail: info@kramerelect.com

P/N: 2900-00003 REV 1