

CARBON MONOXIDE ALARM

CAT. **CO600B/CO605B/CO615B**



CO605B/CO615B

ELECTROCHEMICAL CO SENSING

Most accurate carbon monoxide sensor available* as compared to other technologies. Allows for greater temperature and humidity range variations and more accurate digital display readings (CO615B).

FRONT ACCESS BATTERY

(CO605B/CO615B)
Allows easy battery replacement.

SILENCE/TEST BUTTON

Single button tests alarm functions or silences unwanted alarms.

BACKLIT DIGITAL DISPLAY

(CO615B ONLY)

Identifies CO hazard, stores, recalls and displays highest level of CO detected. Illuminates only when button is pressed or unit is alarming.

REMOTE TEST/SILENCE

(CO615B ONLY)
Patented IR remote test/silence technology can be operated with most household TV/VCR remote controls to test alarm functions or silence unwanted alarms from a distance.

First Alert®

120V AC, 60Hz Plug-In
With Two AA Battery Backup (CO605B & CO615B)

Description:

The First Alert Cat. Nos. CO600B, CO605B and CO615B are direct plug-in, 120V AC, 60Hz single station carbon monoxide alarms specifically designed for residential and institutional applications including sleeping rooms of hospitals, hotels, motels, dormitories and other multi-family dwellings as defined in standard NFPA 720. Models CO600B, CO605B and CO615B comply with UL2034, NFPA 720 and other agencies that model their codes after the above agencies. Model CO600B meets codes where plug-in AC carbon monoxide alarms are allowed. Models CO605B and CO615B meet codes where plug-in AC/DC carbon monoxide alarms are allowed.

First Alert CO600B, CO605B and CO615B feature an electrochemical CO sensor, an 85dB horn, a single button for test/silence and an LED power indicator. An Alarm Action Chart identifies action steps to take if unit is in alarm. For First Alert CO605B & CO615B, the front access battery door allows battery access without removing the unit from the wall. The low power warning indicator will cause the alarm to "chirp" when the batteries need replacing. The low power warning indicator can be silenced for up to 8 hours. First Alert CO615B also features a backlit digital display that shows visual confirmation of CO levels and has Peak Level Memory, remembers and displays the highest levels detected when the Peak Level button is pressed. Backlight illuminates only when any button is pressed or unit is in alarm. In addition, Model CO615B features a line cord and remote control test/silence; using most standard household IR remote controls, the alarm functions can be tested or unwanted alarms silenced.

Models CO600B and CO605B are designed to be plugged directly into a standard non-switched outlet. Model CO615B can be plugged directly into an outlet or the line cord utilized to mount the unit to the wall away from the outlet or to place unit on a tabletop (For tabletop use we recommend the unit be placed no higher than three feet from the floor); mounting anchors and screws are included for wall mounting.



CO600B/CO605B

CO615B



CAT. CO600B/CO605B/CO615B



CO605B/CO615B

120V AC, 60Hz Plug-In With Two AA Battery Backup (CO605B & CO615B)

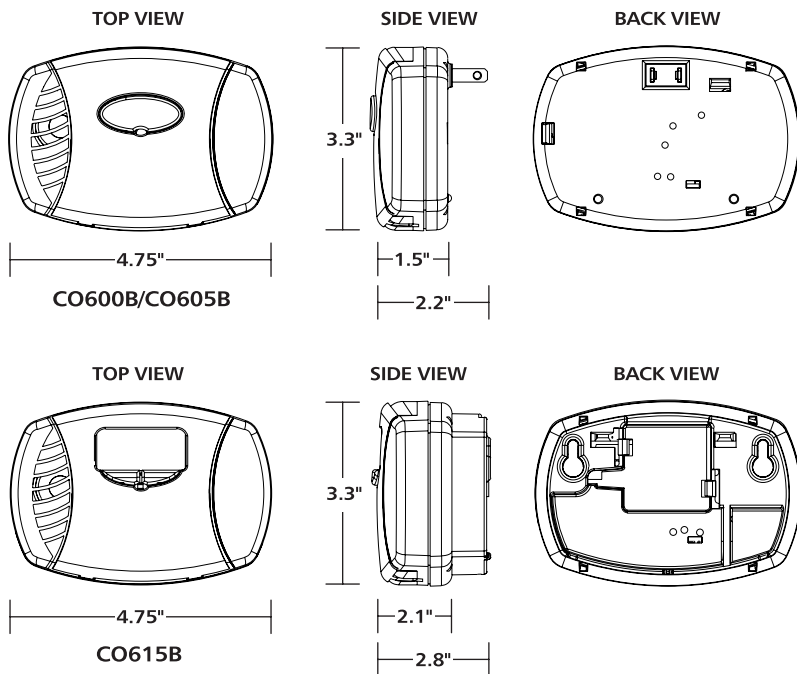

TECHNICAL SPECS:

| | |
|-------------------|--|
| Alarm Dimensions | 3.3"H x 4.75"L x 1.5"D (CO600B, CO605B) 3.3"H x 4.75"L x 2.1"D (CO615B) |
| Weight | 3.8 oz (CO600B) 6.8 oz (CO605B) 8.7 oz (CO615B) |
| Operating Voltage | 120V AC 60Hz Two 1.5V AA Batteries Backup (CO605B & CO615B) |
| Temperature Range | 40°F (4°C) to 100°F (38°C) |
| Humidity Range | 10% to 90% RH |
| Audio Alarm | 85dB at 10 feet |
| Test Button | Electronically simulates a carbon monoxide condition, causing the unit to alarm |
| Alarm Reset | Automatic when carbon monoxide clears; Press Test/Silence button to reset manually |
| Sensor | Electrochemical |
| Indicator LEDs | AC Power: Constant Red LED DC Power: Red LED Flashes once per minute Local Alarm: Audio alarm (4 beeps, pause, 4 beeps) and rapidly flashing Red LED |
| Listing | UL 2034 Standard |

SHIPPING SPECS:

| | CO600B | CO605B | CO615B |
|------------------------------|-----------------------|-----------------------|-----------------------|
| Individual Carton Dimensions | 3.4"H x 5.4"L x 2.3"D | 3.4"H x 5.4"L x 2.3"D | 3.4"H x 5.4"L x 2.8"D |
| Weight | 0.32 lbs | 0.51 lbs | 0.63 lbs |
| Cube | 0.02 ft ³ | 0.02 ft ³ | 0.03 ft ³ |
| UPC | 0 29054 00073 6 | 0 29054 00072 9 | 0 29054 00192 4 |
| Master Carton Dimensions | 6.1"H x 7.4"L x 7.4"D | 6.1"H x 7.4"L x 7.4"D | 6.1"H x 7.4"L x 8.9"D |
| Master Pack | 6 | 6 | 6 |
| Weight | 2.17 lbs | 3.31 lbs. | 4.03 lbs |
| Cube | .19 ft ³ | .19 ft ³ | .23 ft ³ |
| UPC | 600 29054 00073 8 | 600 29054 00072 1 | 600 29054 00192 6 |
| Pallet Information | | | |
| Cases per Layer | 30 | 30 | 25 |
| Number of Layers | 6 | 6 | 6 |
| Cases per Pallet | 180 | 180 | 150 |
| Cube | 34.80 ft ³ | 34.80 ft ³ | 34.87 ft ³ |
| Weight | 390.6 lbs. | 595.8 lbs. | 604.5 lbs |

Distributed by:

*Based on claims of major manufacturers.



Manufactured By:
BRK Brands, Inc.
3901 Liberty Street Road
Aurora, IL 60504-8122

www.firstalert.com

First Alert® is a registered trademark of the First Alert Trust

©2007 BRK Brands, Inc.
All rights reserved
CM2796

ARCHITECTURAL AND ENGINEERING SPECIFICATION:

1. Electrochemical carbon monoxide sensor.
2. The unit shall be capable of self restoring.
3. The unit shall feature a backlit digital display (CO615B only) that shows visual confirmation of CO levels and has Peak Level Memory that remembers and displays the highest level detected when the Peak Level button is pressed.
4. Powered by 120V AC, 60Hz; Model CO615B features a 7' line cord to allow for multiple placement options. Models CO605B and CO615B will also have two 1.5V AA batteries.
5. A solid state piezo horn rated at 85dB at 10 feet.
6. A visual LED (red) power-on indicator to confirm unit is receiving power or confirm unit has switched to battery backup mode, for those models with battery backup (CO605B, CO615B).
7. A single button test/silence feature. Test button should check all alarm functions by simulating a carbon monoxide condition, causing the unit to alarm. The silence feature is to temporarily silence unwanted alarms. Model CO615B features a remote control test/silence; using most standard household IR remote controls, the alarm functions can be tested or unwanted alarms silenced.
8. The unit shall be capable of operating between 40°F (4°C) and 100°F (38°C) and relative humidity between 10% and 90%.
9. The unit will alarm at the following CO levels: 70 PPM between 60 and 240 minutes; 150 PPM between 10 and 50 minutes; 400 PPM between 4 and 15 minutes.
10. The unit shall include mounting hardware and shall be listed for direct plug mounting for all units or wall mounting or tabletop placement for model CO615B only (For tabletop use we recommend the unit be placed no higher than three feet from the floor).
11. The unit shall at a minimum meet the requirements of UL2034 and NFPA 720.

INSTALLATION OF CARBON MONOXIDE ALARM

Installation of this carbon monoxide alarm must confirm to NFPA 720. Always check your local building codes. Follow all instructions for placement as outlined in the user's manual in sections titled "Recommended Locations for Carbon Monoxide Alarms" and "Locations to Avoid for Carbon Monoxide Alarms."