

Rosemount 2051 Pressure Transmitter with HART 4-20 mA and HART 1-5 Vdc Low Power Protocol

Rosemount 2051CF Series Flowmeter Transmitter with HART 4-20 mA and HART 1-5 Vdc Low Power Protocol

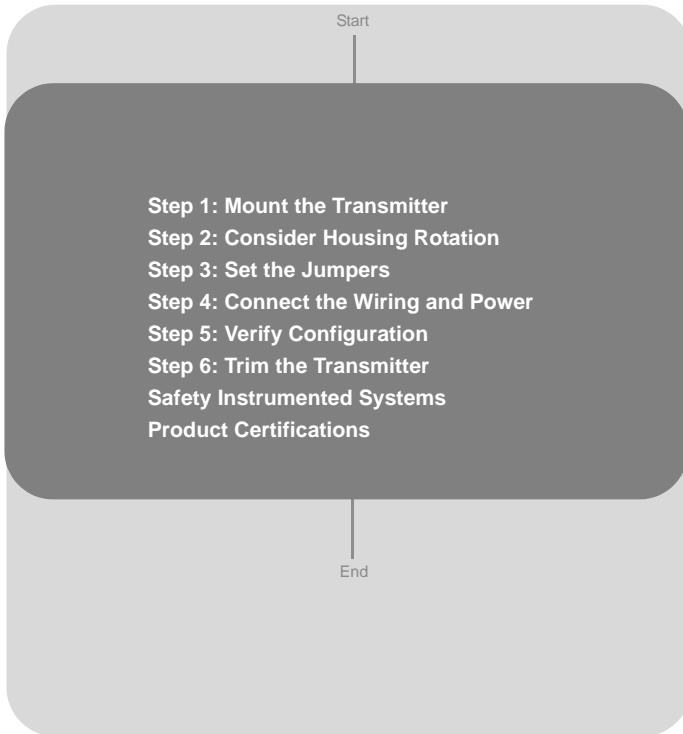

ROSEMOUNT

www.rosemount.com



EMERSON
Process Management

Rosemount 2051

© 2010 Rosemount Inc. All rights reserved. All marks property of owner. Rosemount and the Rosemount logotype are registered trademarks of Rosemount Inc.

Rosemount Inc.

8200 Market Boulevard
Chanhassen, MN USA 55317
T (US) (800) 999-9307
T (Intl) (952) 906-8888
F (952) 949-7001

Emerson Process Management Asia Pacific Private Limited

1 Pandan Crescent
Singapore 128461
T (65) 6777 8211
F (65) 6777 0947/65 6777 0743

Emerson Process Management GmbH & Co. OHG

Argelsrieder Feld 3
82234 Wessling
Germany
T 49 (8153) 9390
F 49 (8153) 939172

Beijing Rosemount Far East Instrument Co., Limited

No. 6 North Street,
Hepingli, Dong Cheng District
Beijing 100013, China
T (86) (10) 6428 2233
F (86) (10) 6422 8586

⚠ IMPORTANT NOTICE

This installation guide provides basic guidelines for Rosemount 2051 transmitters. It does not provide instructions for configuration, diagnostics, maintenance, service, troubleshooting, Explosion-proof, Flameproof, or intrinsically safe (I.S.) installations. Refer to the 2051 reference manual (document number 00809-0100-4101) for more instruction. This manual is also available electronically on www.emersonprocess.com/rosemount.

⚠ WARNING**Explosions could result in death or serious injury:**

Installation of this transmitter in an explosive environment must be in accordance with the appropriate local, national, and international standards, codes, and practices. Please review the approvals section of the 2051 reference manual for any restrictions associated with a safe installation.

- Before connecting a HART-based communicator in an explosive atmosphere, make sure the instruments in the loop are installed in accordance with intrinsically safe or non-incendive field wiring practices.
- In an Explosion-proof/Flameproof installation, do not remove the transmitter covers when power is applied to the unit.

Process leaks may cause harm or result in death.

- To avoid process leaks, only use the o-ring designed to seal with the corresponding flange adapter.

Electrical shock can result in death or serious injury.

- Avoid contact with the leads and the terminals. High voltage that may be present on leads can cause electrical shock.

Conduit/Cable Entries

- Unless marked, the conduit/cable entries in the transmitter housing use a $1/2$ -14 NPT thread form. Only use plugs, adapters, glands or conduit with a compatible thread form when closing these entries.

STEP 1: MOUNT THE TRANSMITTER

A. Applications

Liquid Flow Applications

1. Place taps to the side of the line.
2. Mount beside or below the taps.
3. Mount the transmitter so that the drain/vent valves are oriented upward.

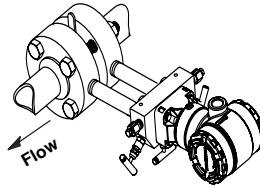

Gas Flow Applications

1. Place taps in the top or side of the line.
2. Mount beside or above the taps.

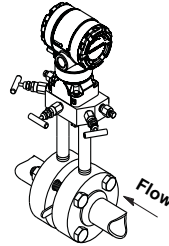

Steam Flow Applications

1. Place taps to the side of the line.
2. Mount beside or below the taps.
3. Fill impulse lines with water.

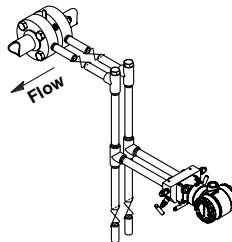

Rosemount 2051

STEP 1 CONTINUED...

B. Optional Mounting Brackets

When installing the transmitter to one of the optional mounting brackets, torque the bracket bolts to 125 in.-lbs. (0,9 N-m).

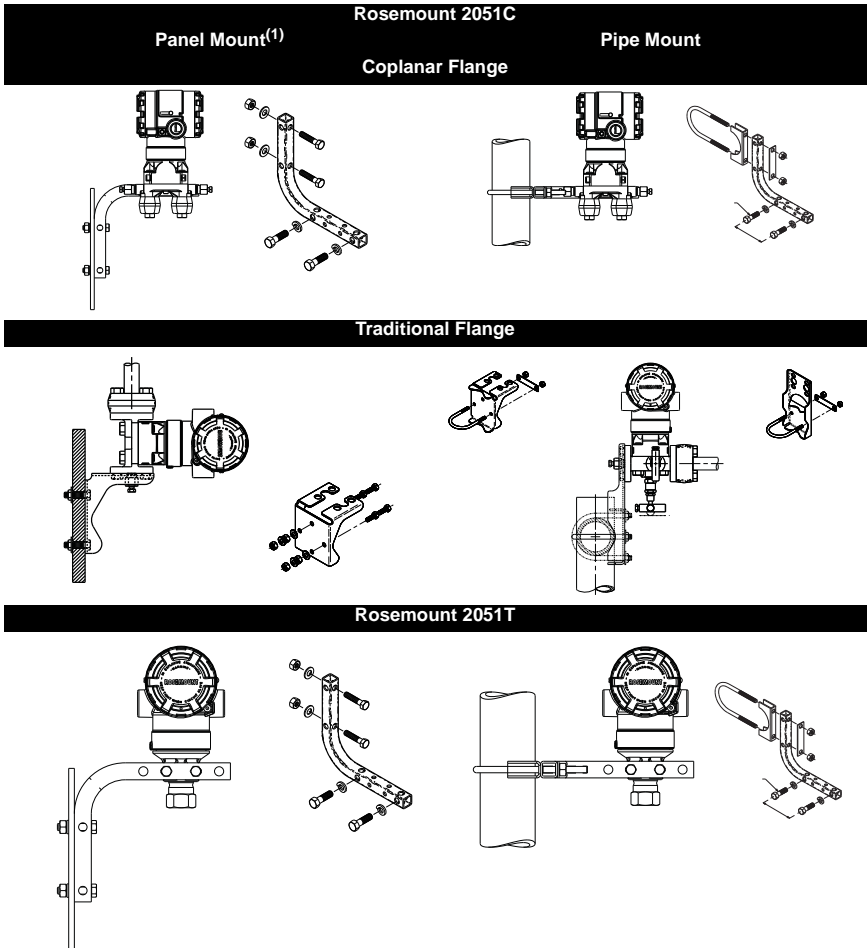

(1) Panel bolts are customer supplied.

STEP 1 CONTINUED...

C. Bolting Considerations

If the transmitter installation requires assembly of the process flanges, manifolds, or flange adapters, follow these assembly guidelines to ensure a tight seal for optimal performance characteristics of the transmitters. Use only bolts supplied with the transmitter or sold by Emerson as spare parts. Figure 1 illustrates common transmitter assemblies with the bolt length required for proper transmitter assembly.

Figure 1. Common Transmitter Assemblies

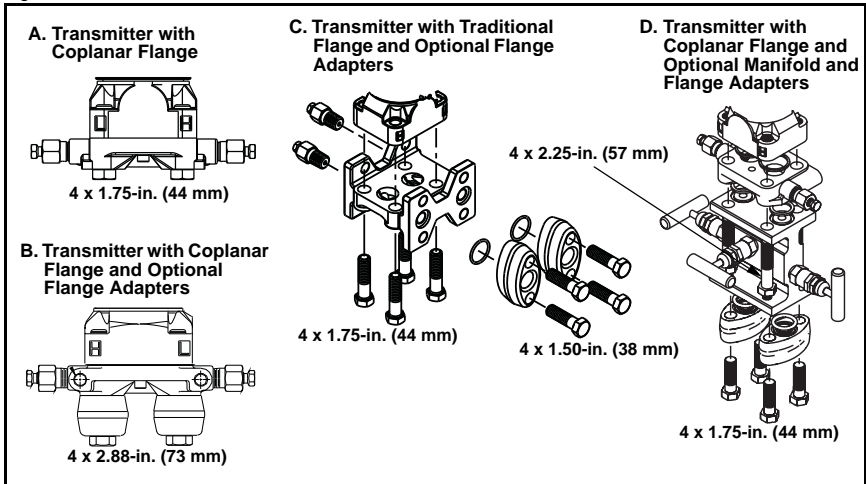

Bolts are typically carbon steel or stainless steel. Confirm the material by viewing the markings on the head of the bolt and referencing Figure 2. If bolt material is not shown in Figure 2, contact the local Emerson Process Management representative for more information.









Use the following bolt installation procedure:

1. Carbon steel bolts do not require lubrication and the stainless steel bolts are coated with a lubricant to ease installation. However, no additional lubricant should be applied when installing either type of bolt.
2. Finger-tighten the bolts.
3. Torque the bolts to the initial torque value using a crossing pattern. See Figure 2 for initial torque value.
4. Torque the bolts to the final torque value using the same crossing pattern. See Figure 2 for final torque value.
5. Verify that the flange bolts are protruding through the isolator plate before applying pressure.

Rosemount 2051

STEP 1 CONTINUED...

Figure 2. Torque values for the flange and flange adapter bolts

Bolt Material	Head Markings	Initial Torque	Final Torque
Carbon Steel (CS)	 	300 in.-lbs.	650 in.-lbs.
Stainless Steel (SST)		150 in.-lbs.	300 in.-lbs.
			
			
			

D. O-rings with Flange Adapters

⚠ WARNING

Failure to install proper flange adapter O-rings may cause process leaks, which can result in death or serious injury. The two flange adapters are distinguished by unique O-ring grooves. Only use the O-ring that is designed for its specific flange adapter, as shown below.

Rosemount 3051S / 3051 / 2051 / 3095

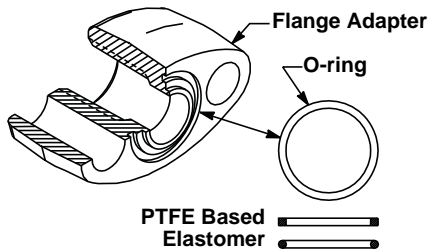
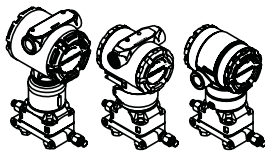

Rosemount 1151

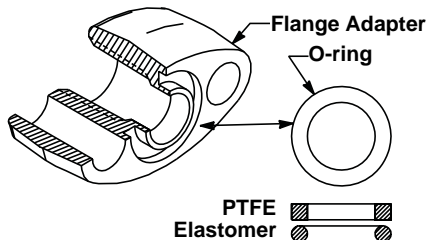

⚠ Whenever the flanges or adapters are removed, visually inspect the o-rings. Replace them if there are any signs of damage, such as nicks or cuts. If you replace the o-rings, re-torque the flange bolts and alignment screws after installation to compensate for seating of the PTFE o-ring.

E. Inline Gage Transmitter Orientation

The low side pressure port (atmospheric reference) on the inline gage transmitter is located in the neck of the transmitter, behind the housing. The vent path is 360° around the transmitter between the housing and sensor. (See Figure 3.)

Keep the vent path free of any obstruction, including but not limited to paint, dust, and lubrication by mounting the transmitter so that the contaminants can drain away.

Figure 3. Inline Gage Transmitter

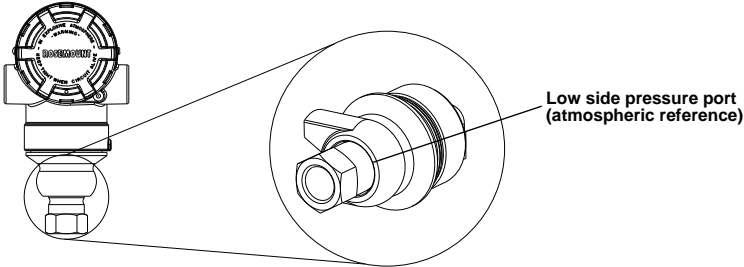

STEP 2: CONSIDER HOUSING ROTATION

To improve field access to wiring or to better view the optional LCD display:

1. Loosen the housing rotation set screw.
2. First rotate the housing clockwise to the desired location. If the desired location cannot be achieved due to thread limit, rotate the housing counter clockwise to the desired location (up to 360° from thread limit).
3. Retighten the housing rotation set screw.

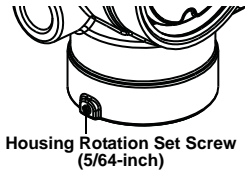

STEP 3: SET THE JUMPERS

If alarm and security jumpers are not installed, the transmitter will operate normally with the default alarm condition alarm *high* and the security *off*.

1. If the transmitter is installed, secure the loop, and remove power.
2. Remove the housing cover opposite the field terminal side. Do not remove the instrument cover in explosive atmospheres when the circuit is live.
3. Reposition the jumper. Avoid contact with the leads and the terminals. See Figure 4 for the location of the jumper and the ON and OFF positions.
4. Reattach the transmitter cover. The cover must be fully engaged to comply with explosion-proof requirements.

Rosemount 2051

Figure 4. 2051 Transmitter Electronics Board

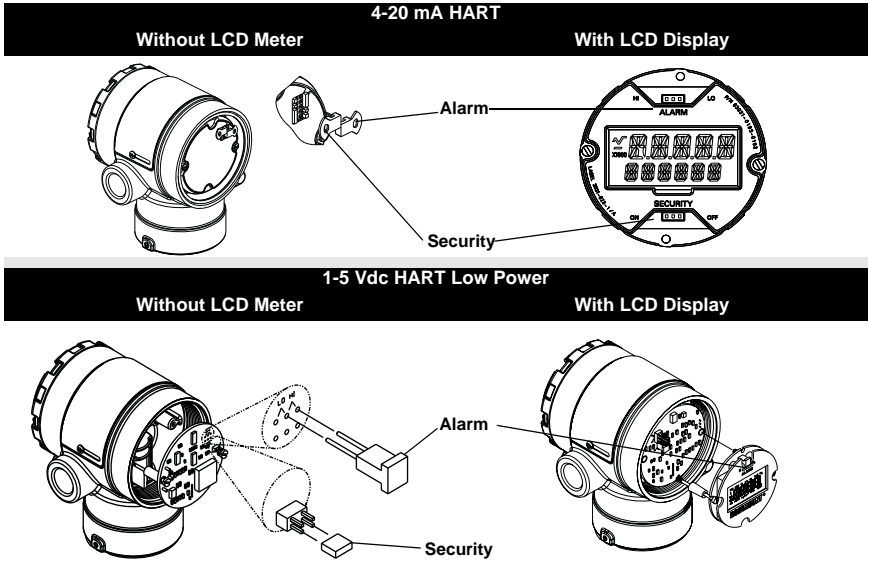

STEP 4: CONNECT THE WIRING AND POWER

Use the following steps to wire the transmitter:

1. Remove the housing cover on the FIELD TERMINALS side.
2. Connect the positive lead to the "+" terminal (PWR/COMM) and the negative lead to the "-" terminal.

Figure 5. 4–20 mA HART Transmitter Wiring Diagrams

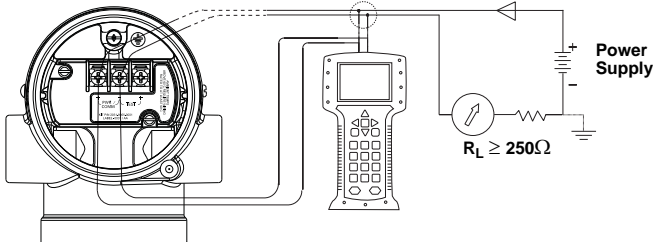
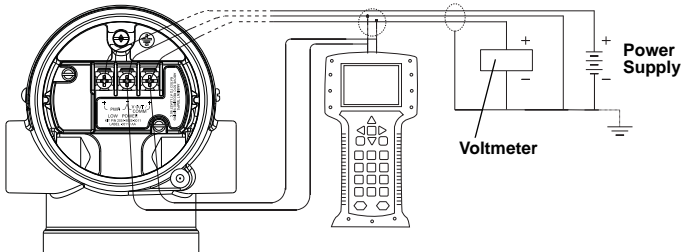

Figure 6. 1-5 Vdc HART Low Power Transmitter Wiring



Installation of the transient protection terminal block does not provide transient protection unless the 2051 case is properly grounded.

3. Ensure proper grounding. It is important that the instrument cable shield:
 - be trimmed close and insulated from touching the transmitter housing.
 - be connected to the next shield if cable is routed through a junction box.
 - be connected to a good earth ground at the power supply end.

Rosemount 2051

Figure 7. Wiring

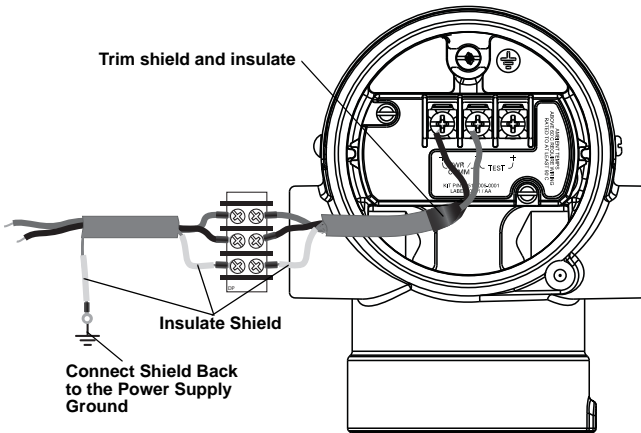
**NOTE**

Do not connect the powered signal wiring to the test terminals. Power could damage the test diode in the test connection. Shielded twisted pair cable should be used for best results. Use 24 AWG or larger wire and do not exceed 5,000 feet (1500 meters).

4. Plug and seal unused conduit connections.
5. If applicable, install wiring with a drip loop. Arrange the drip loop so the bottom is lower than the conduit connections and the transmitter housing.
6. Replace the housing cover.

Quick Installation Guide

00825-0100-4101, Rev EA
June 2010

Rosemount 2051

Power Supply for 4-20 mA HART

Transmitter operates on 10.5 - 42.4 Vdc. The dc power supply should provide power with less than two percent ripple.

Figure 8. Load Limitation

$$\text{Maximum Loop Resistance} = 43.5 * (\text{Power Supply Voltage} - 10.5)$$

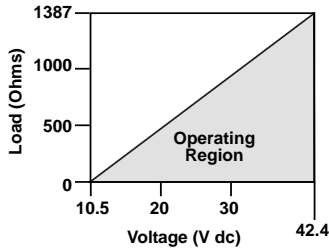

The Field Communicator requires a minimum loop resistance of 250Ω for communication.

The total resistance load is the sum of the resistance of the signal leads and the load resistance of the controller, indicator, and related pieces. Note that the resistance of intrinsic safety barriers, if used, must be included.

Power Supply for 1-5 Vdc HART Low Power

Low power transmitters operate on 9–28 Vdc. The dc power supply should provide power with less than two percent ripple. The V_{out} load should be 100 kW or greater.

Rosemount 2051

STEP 5: VERIFY CONFIGURATION**NOTE:**

A check (P) indicates the basic configuration parameters. At minimum, these parameters should be verified as part of the configuration and startup procedure.

Table 1. Field Communicator Fast Key Sequence

Function	4-20 mA HART	1-5 Vdc HART Low Power
✓ Alarm and Saturation Levels	1, 4, 2, 7	N/A
Analog Output Alarm Type	1, 4, 3, 2, 4	1, 4, 3, 2, 4
Burst Mode Control	1, 4, 3, 3, 3	1, 4, 3, 3, 3
Burst Operation	1, 4, 3, 3, 4	1, 4, 3, 3, 4
Custom Meter Configuration	1, 3, 7, 2	N/A
Custom Meter Value	1, 4, 3, 4, 3	N/A
✓ Damping	1, 3, 6	1, 3, 6
Date	1, 3, 4, 1	1, 3, 4, 1
Descriptor	1, 3, 4, 2	1, 3, 4, 2
Digital To Analog Trim (4-20 mA Output)	1, 2, 3, 2, 1	1, 2, 3, 2, 1
Disable Local Span/Zero Adjustment	1, 4, 4, 1, 7	1, 4, 4, 1, 7
Field Device Information	1, 4, 4, 1	1, 4, 4, 1
Full Trim	1, 2, 3, 3	1, 2, 3, 3
Keypad Input – Rerange	1, 2, 3, 1, 1	1, 2, 3, 1, 1
Local Zero and Span Control	1, 4, 4, 1, 7	1, 4, 4, 1, 7
Loop Test	1, 2, 2	1, 2, 2
Lower Sensor Trim	1, 2, 3, 3, 2	1, 2, 3, 3, 2
Message	1, 3, 4, 3	1, 3, 4, 3
Meter Options	1, 4, 3, 4	N/A
Number of Requested Preambles	1, 4, 3, 3, 2	1, 4, 3, 3, 2
Poll Address	1, 4, 3, 3, 1	1, 4, 3, 3, 1
Poll a Multidropped Transmitter	Left Arrow, 4, 1, 1	Left Arrow, 4, 1, 1
✓ Range Values	1, 3, 3	1, 3, 3
Rerange	1, 2, 3, 1	1, 2, 3, 1
Scaled D/A Trim (4–20 mA Output)	1, 2, 3, 2, 2	1, 2, 3, 2, 2
Self Test (Transmitter)	1, 2, 1, 1	1, 2, 1, 1
Sensor Info	1, 4, 4, 2	1, 4, 4, 2
Sensor Temperature	1, 1, 4	1, 1, 4
Sensor Trim Points	1, 2, 3, 3, 4	1, 2, 3, 3, 4
Status	1, 2, 1, 2	1, 2, 1, 2
✓ Tag	1, 3, 1	1, 3, 1
✓ Transfer Function (Setting Output Type)	1, 3, 5	1, 3, 5
Transmitter Security (Write Protect)	1, 3, 4, 4	1, 3, 4, 4
Trim Analog Output	1, 2, 3, 2	1, 2, 3, 2
✓ Units (Process Variable)	1, 3, 2	1, 3, 2
Upper Sensor Trim	1, 2, 3, 3, 3	1, 2, 3, 3, 3
Zero Trim	1, 2, 3, 3, 1	1, 2, 3, 3, 1

STEP 6: TRIM THE TRANSMITTER

NOTE

Transmitters are shipped fully calibrated per request or by the factory default of full scale (span = upper range limit).

Zero Trim

A zero trim is a single-point adjustment used for compensating mounting position effects. When performing a zero trim, ensure that the equalizing valve is open and all wet legs are filled to the correct level.

There are two methods to compensate for mounting effects:

- Field Communicator
- Transmitter Zero Adjustment Buttons

Select the appropriate method and follow instructions below.

Using the Field Communicator

If zero offset is within 3% of URL, follow the “Using the Field Communicator” instructions below. This zero trim will affect the 4-20 mA value, the HART PV, and the display value.

HART Fast Keys	Steps
1, 2, 3, 3, 2	1. Equalize or vent the transmitter and connect Fieldbus communicator. 2. At the menu, input the Fast Key sequence. 3. Follow the commands to perform a zero trim.

Using the Transmitter Zero Adjustment Buttons

Using the Transmitter Zero Adjustment Buttons, the Lower Range Value (LRV) will be set to the pressure applied to the transmitter. This adjustment will affect the 4-20 mA value only. Perform the following steps to perform a rerange using the zero adjustment buttons.

1. Loosen the certifications label screw and slide the label to expose the zero adjustment buttons. See Figure 9.
2. Set the 4 mA point by pressing the zero button for 2 seconds. Verify that the output is 4 mA. The optional LCD will display ZERO PASS.

Figure 9. Zero and Span buttons

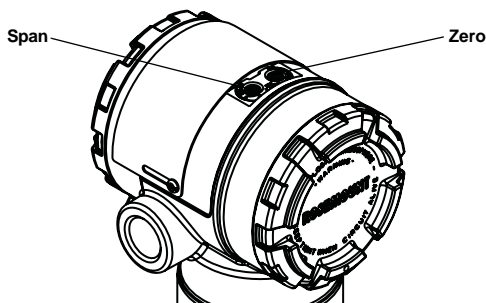

Rosemount 2051

SAFETY INSTRUMENTED SYSTEMS

The following section applies to 2051 transmitters used in SIS applications.

NOTE

Transmitter output is not safety-rated during the following: configuration changes, multidrop, loop test. Alternative means should be used to ensure process safety during transmitter configuration and maintenance activities.

DCS or safety logic solver must be configured to match transmitter configuration. Figure 10 identifies the two alarm level available and their operation values. Position the alarm switch to the required HI or LO alarm position.

Installation

No special installation is required in addition to the standard installation practices outlined in this document. Always ensure a proper seal by installing the electronics housing cover(s) so that metal contacts metal.

The loop must be designed so the terminal voltage does not drop below 10.5 Vdc when the transmitter output is 22.5 mA.

Position the security switch to the "ON" position to prevent accidental or deliberate change of configuration data during normal operation.

Configuration

Use any HART-compliant master to communicate with and verify configuration of the 2051.

User-selected damping will affect the transmitters ability to respond to changes in the applied process. The *damping value + response time* must not exceed the loop requirements.

Figure 10. Alarm Levels

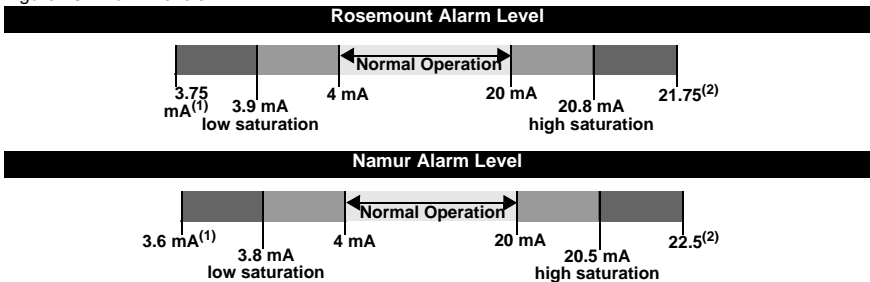

(1) Transmitter Failure, hardware alarm in LO position.

(2) Transmitter Failure, hardware alarm in HI position.

NOTE

Some detected faults are indicated on the analog output at a level above high alarm regardless of the alarm switch selection.

Operation and Maintenance

Proof Test and Inspection

The following proof tests are recommended. Proof test results and corrective actions taken must be documented at

www.emersonprocess.com/rosemount/safety/certtechdocumentation.htm in the event that an error is found in the safety functionality.

Use "Table 1: Field Communicator Fast Key Sequence" to perform a Loop Test, Analog Output Trim, or Sensor Trim. See the 2051 reference manual (00809-0100-4101) for additional information.

Proof Test

This proof test will detect 99% of DU failures not detected by the 2051 automatic diagnostics.

1. Conduct a Loop Test. On HART host/communicator enter the Fast Key Sequence 1, 2, 2.
 - a. Enter the milliampere value representing a high alarm state
 - b. Check the reference meter to verify the mA output corresponds to the entered value.
 - c. Enter the milliampere value representing a low alarm state
 - d. Check the reference meter to verify the mA output corresponds to the entered value.
2. Perform a minimum two point sensor calibration check using the 4-20mA range points as the calibration points.
 - a. If necessary, use one of the "Trim" procedures available in the 2051 reference manual to calibrate.

NOTE

The user determines the proof-test requirements for impulse piping.

Visual Inspection

Not required.

Special Tools

Not required

Product Repair

All failures detected by the transmitter diagnostics or by the proof-test must be reported.

Feedback can be submitted electronically at

www.emersonprocess.com/rosemount/safety/certtechdocumentation.htm.

The 2051 is repairable by major component replacement. Follow the instructions in the 2051 reference manual (document number 00809-0100-4101) for additional information.

Reference

Specifications

The 2051 must be operated in accordance to the functional and performance specifications provided in the 2051 reference manual.

Failure Rate Data

The FMEDA report includes failure rates and common cause Beta factor estimates. This report is available at www.emersonprocess.com/rosemount.

Rosemount 2051

2051 Safety Failure Values

Safety accuracy: 2%⁽¹⁾

Safety response time- 1.5 sec

Product Life

50 years – based on worst case component wear-out mechanisms – not based on wear-out process wetted materials

PRODUCT CERTIFICATIONS

Approved Manufacturing Locations

Emerson Process Management - Rosemount Inc. — Chanhassen, Minnesota, USA

Emerson Process Management — Wessling, Germany

Emerson Process Management Asia Pacific Private Limited — Singapore

Emerson Process Management — Beijing, China

Emerson Process Management — Daman, India

European Directive Information

The EC declaration of conformity can be found on page 20. The most recent revision can be found at www.emersonprocess.com.

Ordinary Location Certification for Factory Mutual

As standard, the transmitter has been examined and tested to determine that the design meets basic electrical, mechanical, and fire protection requirements by FM, a nationally recognized testing laboratory (NRTL) as accredited by the Federal Occupational Safety and Health Administration (OSHA).

(1) A 2% variation of the transmitter mA output is allowed before a safety trip. Trip values in the DCS or Safety Logic Solver should be derated by 2%.

HART Protocol

Hazardous Locations Certifications

North American Certifications

FM Approvals

- E5** Explosion-Proof for Class I, Division 1, Groups B, C, and D. Dust-Ignition-Proof for Class II, Division 1, Groups E, F, and G. Dust-Ignition-Proof for Class III, Division 1. T5 (Ta = 85 °C), Factory Sealed, Enclosure Type 4X
- I5** Intrinsically Safe for use in Class I, Division 1, Groups A, B, C, and D; Class II, Division 1, Groups E, F, and G; Class III, Division 1 when connected per Rosemount drawing 02051-1009; Non-incendive for Class I, Division 2, Groups A, B, C, and D. Temperature Code:T4 (Ta = 70 °C), Enclosure Type 4X
For input parameters see control drawing 02051-1009.

Canadian Standards Association (CSA)

All CSA hazardous approved transmitters are certified per ANSI/ISA 12.27.01-2003.

- E6** Explosion-Proof for Class I, Division 1, Groups B, C, and D. Dust-Ignition-Proof for Class II and Class III, Division 1, Groups E, F, and G. Suitable for Class I, Division 2 Groups A, B, C, and D for indoor and outdoor hazardous locations. Class I Zone 1 Ex d IIC T5. Enclosure type 4X, factory sealed. Single Seal.
- I6** Intrinsically safe approval. Intrinsically safe for Class I, Division 1, Groups A, B, C, and D when connected in accordance with Rosemount drawing 02051-1008. Temperature Code T3C. Class I Zone 1 Ex ia IIC T3C. Single Seal.

European Certifications

- I1** ATEX Intrinsic Safety
Certification No. Baseefa08ATEX0129X  II 1 G
Ex ia IIC T4 (-60 ≤ Ta ≤ +70 °C)
IP66 IP68
CE 1180

Table 2. Input Parameters for 4-20 mA

U _i = 30V
I _i = 200 mA
P _i = 1.0W
C _i = 0.012 μF

Special Conditions for Safe Use (X):

When the optional transient protection terminal block is installed, the apparatus is not capable of withstanding the 500V insulation test required by Clause 6.3.12 of EN60079-11. This must be taken into account when installing the apparatus.

Rosemount 2051

N1 ATEX Type n

Certification No. Baseefa08ATEX0130X  II 3 G

Ex nAnL IIC T4 ($-40 \leq T_a \leq +70 \text{ }^\circ\text{C}$)

$U_i = 42.4 \text{ Vdc max}$

IP66

CE

Special Conditions for Safe Use (X):

When the optional transient protection terminal block is installed, the apparatus is not capable of withstanding a 500V r.m.s. test to case. This must be taken into account on any installation in which it is used, for example by assuring that the supply to the apparatus is galvanically isolated.

E1 ATEX Flame-Proof

Certification No. KEMA 08ATEX0090 X  II 1/2 G

Ex d IIC T6 ($-50 \leq T_a \leq 65 \text{ }^\circ\text{C}$)

Ex d IIC T5 ($-50 \leq T_a \leq 80 \text{ }^\circ\text{C}$)

IP66

CE 1180

$V_{max} = 42.4 \text{ V dc}$

Special Conditions for Safe Use (X):

1. Appropriate ex d blanking plugs, cable glands, and wiring needs to be suitable for a temperature of 90 °C.
2. This device contains a thin wall diaphragm. Installation, maintenance and use shall take into account the environmental conditions to which the diaphragm will be subjected. The manufacturer's instructions for maintenance shall be followed in detail to assure safety during its expected lifetime.
3. The 2051 does not comply with the requirements of IEC 60079-1 Clause 5 for flameproof joints. Contact Emerson Process Management for information on the dimensions of flameproof joints.

ND ATEX Dust

Certification No. Baseefa08ATEX0182X  II 1 D

Dust Rating: Ex tD A20 T115 °C ($-20 \leq T_a \leq 85 \text{ }^\circ\text{C}$)

$V_{max} = 42.4 \text{ V dc}$

$A = 22 \text{ mA}$

CE 1180

Special Conditions for Safe Use (X):

1. The user must ensure that the maximum rated voltage and current (42.4 volts, 22 milliampere, DC) are not exceeded. All connections to other apparatus or associated apparatus shall have control over this voltage and current equivalent to a category "ib" circuit according to EN 60079-1.
2. Cable entries must be used which maintain the ingress protection of the enclosure to at least IP66.
3. Unused cable entries must be filled with suitable blanking plugs which maintain the ingress protection of the enclosure to at least IP66.
4. Cable entries and blanking plugs must be suitable for the ambient range of the apparatus and capable of withstanding a 7J impact test.

IECEX Certifications

- I7** IECEX Intrinsic Safety
Certification No. IECEXBAS08.0045X
Ex ia IIC T4 ($-60 \leq T_a \leq +70$ °C)
CE 1180

Table 3. Input Parameters

$U_i = 30V$
$I_i = 200$ mA
$P_i = 1.0W$
$C_i = 0.012$ μF

Special Conditions for Safe Use (X):

When the optional transient protection terminal block is installed, the apparatus is not capable of withstanding the 500V insulation test required by Clause 6.3.12 of IEC60079-11. This must be taken into account when installing the apparatus.

- E7** IECEX Explosion-Proof (Flame-Proof)
Certification No. IECEXKEM08.0024X
Ex d IIC T6 ($-50 \leq T_a \leq 65$ °C)
Ex d IIC T5 ($-50 \leq T_a \leq 80$ °C)
CE 1180
 $V_{max} = 42.4$ V dc

Special Conditions for Safe Use (X):

1. Appropriate ex d blanking plugs, cable glands, and wiring needs to be suitable for a temperature of 90 °C.
2. This device contains a thin wall diaphragm. Installation, maintenance and use shall take into account the environmental conditions to which the diaphragm will be subjected. The manufacturer's instructions for maintenance shall be followed in detail to assure safety during its expected lifetime.
3. The 2051 does not comply with the requirements of IEC 60079-1 Clause 5 for flameproof joints. Contact Emerson Process Management for information on the dimensions of flameproof joints.

- N7** IECEX Type n
Certification No. IECEXBAS08.0046X
Ex nAnL IIC T4 ($-40 \leq T_a \leq +70$ °C)
 $U_i = 42.4$ Vdc max
CE

Special Conditions for Safe Use (X):

When the optional transient protection terminal block is installed, the apparatus is not capable of withstanding a 500V r.m.s. test to case. This must be taken into account on any installation in which it is used, for example by assuring that the supply to the apparatus is galvanically isolated.

Rosemount 2051

TIIS Certifications

E4 TIIS Flame-Proof
Ex d IIC T6

Inmetro Certifications

E2 Flame-Proof
BR-Ex d IIC T6/T5

I2 Intrinsic Safety
BR-Ex ia IIC T4

GOST (Russia) Certifications

IM Intrinsic Safety
Ex ia IIC T4

EM Flame-Proof
Ex d IIC T5/T6

China (NEPSI) Certifications

E3 Flame-Proof
Certificate No: GYJ081230
Ex d IIC T5/T6

I3 Intrinsic Safety
Certificate No: GYJ081231X
Ex ia IIC T4

Loop / Power	Groups
$U_i = 30V$	HART / FOUNDATION fieldbus / Remote Display / Quick Connect / HART Diagnostics
$U_i = 17.5 V$	FISCO
$I_i = 300 mA$	HART / FOUNDATION fieldbus / Remote Display / Quick Connect / HART Diagnostics
$I_i = 380 mA$	FISCO
$P_i = 1.0 W$	HART / Remote Display / Quick Connect / HART Diagnostics
$P_i = 1.3 W$	FOUNDATION fieldbus
$P_i = 5.32 W$	FISCO
$C_i = 0.012 \mu F$	HART
$C_i = 0$	FOUNDATION fieldbus / FISCO
$L_i = 0$	FOUNDATION fieldbus
$L_i = 10 \mu H$	HART

CCoE Certifications

EW Flame-Proof
Ex d IIC T5 or T6

IW Intrinsic Safety
Ex ia IIC T4

Quick Installation Guide



00825-0100-4101, Rev EA
June 2010

Rosemount 2051

Combinations of Certifications

Stainless steel certification tag is provided when optional approval is specified. Once a device labeled with multiple approval types is installed, it should not be reinstalled using any other approval types. Permanently mark the approval label to distinguish it from unused approval types.

- K1** E1, I1, N1, and ND combination
- K4** E4 and I4 combination
- K5** E5 and I5 combination
- K6** I6 and E6 combination
- K7** E7, I7, and N7 combination
- KA** E1, I1, E6, and I6 combination
- KB** E5, I5, E6, and I6 combination
- KC** E1, I1, E5, and I5 combination
- KD** E1, I1, E5, I5, E6, and I6 combination

ROSEMOUNT	
EC Declaration of Conformity	
No: RMD 1071 Rev. A	
<i>We,</i>	
Rosemount Inc. 8200 Market Boulevard Chanhassen, MN 55317-6985	
<i>declare under our sole responsibility that the product,</i>	
Models 2051 Pressure Transmitter	
<i>manufactured by,</i>	
Rosemount Inc. 12001 Technology Drive Eden Prairie, MN 55344-3695 USA	<i>and</i> 8200 Market Boulevard Chanhassen, MN 55317-9687 USA
<i>to which this declaration relates, is in conformity with the provisions of the European Community Directives, including the latest amendments, as shown in the attached schedule.</i>	
<i>Assumption of conformity is based on the application of the harmonized standards and, when applicable or required, a European Community notified body certification, as shown in the attached schedule.</i>	
 _____ (signature)	Vice President of Global Quality _____ (function name - printed)
Timothy J Laver _____ (name - printed)	15-Aug-2008 _____ (date of issue)

ROSEMOUNT



EC Declaration of Conformity

No: RMD 1071 Rev. A

EMC Directive (2004/108/EC)

All Models 2051 Pressure Transmitters
EN 61326:2006

PED Directive (97/23/EC)

Models 2051CG2, 3, 4, 5; 2051CD2, 3, 4, 5 (also with P9 option); Pressure Transmitters
QS Certificate of Assessment - EC No. PED-H-100
Module H Conformity Assessment

All other model 2051 Pressure Transmitters
Sound Engineering Practice

Transmitter Attachments: Diaphragm Seal - Process Flange - Manifold
Sound Engineering Practice

ATEX Directive (94/9/EC)

Model 2051 Pressure Transmitter

Certificate: BAS08ATEX0129X
Intrinsically Safe - Group II Category 1 G
Ex ia IIC T4 (Ta = -60°C to +70°C)
Ex ia IIC T4 (Ta = -60°C to +60°C) FISCO
Harmonized Standards Used:
EN60079-0:2006; EN60079-11:2007

Certificate: Baseefa08ATEX0130X
Type n - Group II Category 3 G
Ex nA nL IIC T4 (Ta = -40°C to +70°C)
Harmonized Standards Used:
EN60079-0:2006; EN60079-15:2005

Certificate: KEMA08ATEX0090X
Flameproof - Group II Category 1/2 GD
Ex d IIC T6 (-50°C ≤ Ta ≤ +65°C)
Ex d IIC T5 (-50°C ≤ Ta ≤ +80°C)
Harmonized Standards Used:
EN60079-0:2006; EN60079-1:2007; EN60079-26:2007

Certificate: Baseefa08ATEX0182X
Type Dust - Group II Category 1 D
Ex tD A20 T115°C (-20°C ≤ Ta ≤ +85°C)
Harmonized Standards Used:
EN61241-0:2006; EN61241-1:2004

ROSEMOUNT	CE	
EC Declaration of Conformity No: RMD 1071 Rev. A		
PED Notified Body		
Det Norske Veritas (DNV) [Notified Body Number: 0575] Veritasveien 1, N-1322 Hovik, Norway		
ATEX Notified Bodies for EC Type Examination Certificate		
KEMA (KEMA) [Notified Body Number: 0344] Utrechtsweg 310, 6812 AR Arnhem P.O. Box 5185, 6802 ED Arnhem The Netherlands Postbank 6794687		
Baseefa, [Notified Body Number: 1180] Rockhead Business Park Staden Lane Buxton, Derbyshire SK17 9RZ United Kingdom		
ATEX Notified Body for Quality Assurance		
Baseefa, [Notified Body Number: 1180] Rockhead Business Park Staden Lane Buxton, Derbyshire SK17 9RZ United Kingdom		
File ID: 2051_CE Marking	Page 3 of 3	K:\CE_Declarations\2051\2051_RMD1071A_8-26-08.doc