

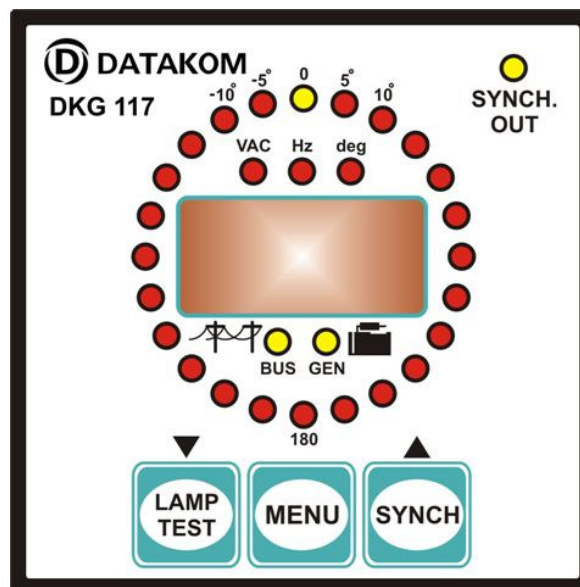

DKG-117 SYNCHROSCOPE AND CHECK SYNCH RELAY



FEATURES

24 led circular synchroscope
 Programmable ΔV , Δf , $\Delta \theta$ for check synch relay
 1 phase genset voltage input
 1 phase busbar voltage input
 Synch Check Enable input
 Dead Bus Enable input
 Auto power off
 Adjustable parameters
 Front panel configurable
 Survives cranking dropouts
 LED displays
 Sealed front panel
 Plug-in connection system for easy replacement
 Small dimensions (72x72x52mm)
 Low cost

MEASUREMENTS

Generator Volt: U-N
 Generator Frequency
 Busbar Volts: R-N
 Busbar Frequency
 Frequency difference busbar-generator
 Voltage difference busbar-generator
 Phase angle busbar-phase U

TABLE OF CONTENTS

Section

- 1. INSTALLATION**
 - 1.1. Introduction to the Control Panel
 - 1.2. Mounting the Unit
 - 1.3. Wiring the Unit
- 2. INPUTS AND OUTPUTS**
- 3. DISPLAYS**
 - 3.1. Led Displays
 - 3.2. Digital Display
- 4. OPERATION**
- 5. OTHER FEATURES**
 - 5.1. Synchronization checking
 - 5.2. Dead bus enable
 - 5.3 Pre-synchronization delay
- 6. PROGRAMMING**
- 7. TROUBLESHOOTING**
- 8. DECLARATION OF CONFORMITY**
- 9. TECHNICAL SPECIFICATIONS**
- 10. CONNECTION DIAGRAM**

1. INSTALLATION

1.1 Introduction to the Control Panel

The unit is a display and control module used in manual synchronization and protection panels. It monitors the voltage and frequency of 2 independent power networks and shows the measured values on its 3-digit digital display. The 24 led circular synchroscope indicates the true instantaneous phase angle between the networks.

The synchronization may be made between a genset and a genset busbar, or between a genset busbar and mains.

The unit is designed to provide user friendliness for both the installer and the user. Programming is usually unnecessary, as the factory settings have been carefully selected to fit most applications. However programmable parameters allow complete control over the operation. Programmed parameters are stored in a Non Volatile Memory and thus all information is retained even in the event of complete loss of power.

The measured parameters are:

Genset voltage phase U to neutral
Genset frequency
Busbar voltage phase R to neutral
Busbar frequency
Frequency difference busbar-genset
Voltage difference busbar-genset
Phase angle busbar-genset

1.2 Mounting the Unit

The unit is designed for panel mounting. The user should not be able to access parts of the unit other than the front panel.

Mount the unit on a flat, vertical surface. The unit fits into a standard panel meter opening of 68x68 millimeters. Before mounting, remove the retaining steel spring and connectors from the unit, then pass the unit through the mounting opening. The unit will be maintained in its position by the steel spring.



Engine body must be grounded for correct operation of the unit, otherwise incorrect voltage and frequency measurements may occur.

1.3 Wiring the Unit



WARNING: THE UNIT IS NOT FUSED.
Use external fuses for
Generator phase: U
Busbar phase: R
Battery positive: BAT(+).
Install the fuses as nearly as possible to
the unit in a place easily accessible for the user.
The fuse rating should be 6 Amps.



WARNING: ELECTRICITY CAN KILL
ALWAYS disconnect the power **BEFORE** connecting the unit.



- 1) *ALWAYS* remove the plug connectors when inserting wires with a screwdriver.
- 2) *ALWAYS* refer to the National Wiring Regulations when conducting installation.
- 3) An appropriate and readily accessible set of disconnection devices (e.g. automatic fuses) **MUST** be provided as part of the installation.
- 4) The disconnection device must **NOT** be fitted in a flexible cord.
- 5) The building mains supply **MUST** incorporate appropriate short-circuit backup protection (e.g. a fuse or circuit breaker) of High Breaking Capacity (HBC, at least 1500A).
- 6) Use cables of adequate current carrying capacity (at least 0.75mm²) and temperature range.

2. INPUTS AND OUTPUTS

Term	Function	Technical data	Description
1	CHECK SYNCH RELAY COMMON TERMINAL	Relay output, 10A-DC	These outputs provide energy to the generator paralleling contactor. If the genset phase voltage is not within programmed limits, or if the genset phase voltage, frequency and phase angle are not within the programmed limits compared to the busbar, this relay will not be energized. If the busbar is not powered up, synchronization checking may be overridden with the DEAD BUS ENABLE input signal. The relay output is rated to 10Amps/28VDC. Do not connect to AC voltages.
2	CHECK SYNCH RELAY NORMALLY OPEN TERMINAL		
3	CHECK SYNCH RELAY NORMALLY CLOSED TERMINAL		
4	DEAD BUS ENABLE		This input will be driven by a 'normally open' contact, switching to battery- when active. If the signal is active, the unit will be allowed to close the relay output when the voltage level at the busbar input is below the set limit. See programming section for more details on level setting.
5	GROUND	0 VDC	Power supply negative connection.
6	BATTERY POSITIVE	+12 or 24VDC	The positive terminal of the DC Supply shall be connected to this terminal. The unit operates on both 12V and 24V battery systems.
7	SYNCHRONIZATION CHECK ENABLE		This input will be driven by a 'normally open' contact, switching to battery- when active. If the signal is active, the unit will be allowed to close the relay output when the synchronization conditions are met. Otherwise it will not close the relay. This input may be hard wired to battery negative for the fastest synchronization. A closed to open transition on this input will cause the SYNCH RELAY to deenergize. The synchronization checking may also be initiated or terminated manually by depressing the SYNCH pushbutton.
8	GENSET PHASE-U	Generator phase input, 0-300V-AC	Connect the generator phase to this input. The generator phase voltage upper and lower limits are programmable.
9	UNUSED	No connection	Please leave open.
10	GENERATOR NEUTRAL	Input, 0-300V-AC	Neutral terminal for the generator phase.
11	BUSBAR NEUTRAL	Input, 0-300V-AC	Neutral terminal for the busbar phase.
12	UNUSED	No connection	Please leave open.
13	BUSBAR PHASE-R	Busbar phase input, 0-300V-AC	Connect the busbar phase to this input. The busbar voltage upper and lower limits are programmable.

3. DISPLAYS

3.1 Led Displays

The unit has 30 LEDs, divided in 4 groups:

-Group_1: Synchroscope: this group indicates the instantaneous phase angle of the genset voltage with reference to the busbar voltage. When both networks are in synchronization, the upper center yellow led with 0° mark will illuminate. When the genset frequency is higher than the busbar frequency, then the synchroscope will turn in the clockwise direction. When the genset frequency is lower than the busbar frequency, then the synchroscope will turn in the counter-clockwise direction.

-Group_2: Status: This group indicates the current status of the busbar and genset voltages and the synchronization checking status.

-Group_3: SYNCH: This led will indicate the status of the SYNCH CHECK relay output.

-Group_4: Unit: This group indicates the unit of the value shown on the digital display.

Function	Color	Description
SYNCHROSCOPE	Red and Yellow	When both busbar and genset voltages are within programmed limits, the synchroscope will illuminate automatically. Only one of the leds turns on at a time. The led indicates the phase angle between the busbar phase and the genset phase U. If the right hand side of the graph is illuminated, this means that the genset phase is leading (in advance) the busbar. If the left hand side of the graph is illuminated, this means that the genset phase is lagging (in retard). A clockwise scrolling of the led graph means that the genset frequency is higher than the busbar frequency. A counter-clockwise scrolling of the led graph means that the genset frequency is lower than the busbar frequency.
GENERATOR	Yellow	The LED will turn off if the genset phase voltage is outside the set limits. It will flash when the genset phase voltage is within the limits and the synchronization is not checked. It turns on steadily when the synchronization is checked.
BUS	Yellow	The LED will turn on when the busbar voltage is within the limits.
SYNCHRONIZED	Yellow	The LED will turn on when the CHECK SYNCH relay is energized. The synchronization checking may be initiated or terminated either manually by depressing the SYNCH pushbutton or with the SYNCHRONIZATION CHECK ENABLE signal input.
UNIT GROUP	Red	This group indicates the unit of the value displayed in the digital display. Different values may be scrolled by pressing the MENU key.

3.2 Digital Display

The unit has a three digit seven segment display. It shows:

- Measured parameters,
- Parameter names,
- Program parameters.

The navigation between different parameters is made with the **MENU** pushbutton. When the MENU key is hold pressed, the parameter name will be displayed.

By pressing the MENU key, below values may be displayed:

- U1**: busbar phase to neutral voltage
- U2**: genset phase to neutral voltage
- dU**: voltage difference between busbar and genset phases
- F1**: busbar frequency
- F2**: genset frequency
- dF**: frequency difference between busbar and genset
- deg**: phase angle between busbar and genset phases (degrees)

4. OPERATION

The unit is designed for **continuous operation** from the genset battery voltage (12 or 24 volts DC). It will shut-off its displays in 1 minute if there is no voltage at the AC inputs and if no key is pressed. It will power-up automatically when voltage is applied to either genset or busbar voltage input or any front panel pushbutton is depressed.

The **synchroscope display** will illuminate automatically if both genset and busbar phase voltages are within their programmed limits. Otherwise the synchroscope will turn off to prevent the display of irrelevant information.

The **GEN led** will turn off if the genset phase voltage is outside the set limits. It will flash when the genset phase voltage is within the limits and the synchronization checking is disabled. It turns on steadily when the synchronization checking is enabled. Please check the PROGRAMMING section for limit setting.

The **BUS led** will turn off if the busbar phase voltage is outside the set limits. It will turn on steadily if the busbar phase voltage is within the limits. Please check the PROGRAMMING section for limit setting.

The **synchronization checking** is initiated either manually by depressing the **SYNCH** pushbutton or with the **SYNCHRONIZATION CHECK ENABLE** signal input.

If the synchronization checking is enabled, the unit will be allowed to close the relay output when the synchronization conditions are met. Otherwise it will not close the relay even if conditions are met. The SYNCHRONIZATION CHECK ENABLE signal input may be **hard-wired** to battery negative for the immediate synchronization after genset runs. However a programmable **pre-synchronization delay** (P_08) may be inserted with the programming menu in order to allow the genset to stabilize (or even to heat up if needed).

The synchronization checking is not timed. The unit will continue checking the synchronization until the synchronization conditions are satisfied or the process terminated with the SYNCH key or the SYNCHRONIZATION CHECK ENABLE signal.

A closed to open transition on the SYNCHRONIZATION CHECK ENABLE input will cause the SYNCH RELAY to deenergize and the synchronization checking to terminate. The synch checking may also be initiated or terminated manually by depressing the **SYNCH** pushbutton.

Once the SYNCH CHECK relay is energized, further synchronization checking may be enabled or disabled following the value of the program parameter P_09. If the synchronization checking is disabled after closing the SYNCH CHECK relay, the relay output **will not deenergize** even if the paralleling contactor fails to close. It is the responsibility of the panel builder to use a quickly closing contactor.

5. OTHER FEATURES

5.1 Synchronization Checking

The unit will check the synchronization only when both genset and busbar phase voltages are within programmed limits and the synchronization is enabled either with the SYNCHRONIZATION CHECK ENABLE signal or the SYNCH pushbutton.

If both busbar and genset phase voltages are within programmed limits, then the synchroscope will illuminate. The synchroscope will show the phase angle between busbar and genset phase.

The synchronization checking consists of the verification of below conditions during 4 consecutive busbar cycles:

- the busbar phase voltage should be between limits set by **P_00** and **P_01**
- the genset phase voltage should be between limits set by **P_02** and **P_03**
- the frequency difference between the busbar and genset should not exceed the limit set by **P_04**
- the voltage difference between the busbar and genset phases should not exceed the limit set by **P_05**
- the phase angle between the busbar and genset phase should not exceed the limit set by **P_06**

If both above conditions are satisfied for 4 consecutive busbar cycles then the **CHECK SYNCH** relay will be immediately energized.



**WARNING: If the synchronization is lost after the CHECK SYNCH relay is operated, the relay will not release.
It is the responsibility of the panel builder to use a quickly closing contactor.**

5.2 Dead bus enable

It may be required from a genset to close on an unpowered bus (dead bus). This is especially the case for multi-genset synchronization systems, where one of the gensets must feed the busbar in order to serve other gensets as a reference for synchronization.

When active, the DEAD BUS ENABLE input signal will force the SYNCH relay to close when **both** of below conditions are met:

- synchronization checking enabled (either via input or pushbutton)
- the genset phase voltage is within limits set by **P_02** and **P_03**,
- the busbar voltage is below the limit set by **P_00**.

Please note that, if the busbar voltage is above the set limit, the SYNCH CHECK relay output **will not close** even if the DEAD BUS ENABLE signal is active. This feature is installed in order to prevent an eventual non-synchronized closing of the paralleling contactor.

5.3 Pre-synchronization delay

Especially on engines without a body heater, it may be desired that the genset should not take the load immediately after running.

The unit offers a timer controlled pre-synchronization delay feature. When the genset voltage is within the limits, the engine will be allowed to run during parameter **P_08**, and then the synchronization checking will be enabled. The default factory setting of this parameter is 3 seconds. If a delay is not requested, the parameter may be set to **0**.

6. PROGRAMMING

The program mode is used to program the timers and operational limits of the unit.

To **enter the program mode**, press the **MENU** button for 5 seconds.

The program mode will not affect the operation of the unit. Thus programs may be modified anytime, even while the genset is running.

In program mode, when the **MENU** key is pressed the display will show the program parameter number, when the **MENU** key is released the display will show the program parameter value. The first program number is "000".

Each depression of the **MENU** key will cause the display to switch to the next program parameter. After the last parameter, the display switches back to the first parameter. The displayed parameter value may be increased or decreased using "▲" and "▼" keys. If these keys are hold pressed, the program value will be increased/decreased by steps of 10.

Program parameters are kept in a non-volatile memory and are not affected from power failures.

The program mode will be cancelled automatically after 20 seconds if no key is pressed.

Pgm	Definition	Unit	Std Val	Description
0	Busbar Voltage Low Limit	V	100	If the busbar phase voltage goes under this limit, it means that the busbar is not energized.
1	Busbar Voltage High Limit	V	500	If the busbar phase voltage goes over this limit, it means that the busbar is not energized.
2	Gen. Voltage Low Limit	V	180	If the genset phase voltage goes under this limit, it means that the genset is not running. If the genset phase voltage goes under this limit when the SYNCH CHECK output is energized, it will deenergize immediately.
3	Gen. Voltage High Limit	V	270	If the genset phase voltage goes over this limit, it means that the genset is not running. If the genset phase voltage goes over this limit when the SYNCH CHECK output is energized, it will deenergize immediately.
4	Frequency difference	Hz	1.0	If the frequency difference between the busbar and the genset is above this limit, then the synchronization will not be accepted.
5	Voltage difference	V	10	If the difference between the busbar and the genset phase voltages are above this limit, then the synchronization will not be accepted.
6	Phase angle	deg.	5	If the phase angle between the busbar and the genset phase voltages are above this limit, then the synchronization will not be accepted.
7	Hysteresis Voltage	V	8	This parameter provides the busbar and genset voltage limits with a hysteresis feature in order to prevent faulty decisions. For example, when the busbar is present, the busbar voltage low limit will be used as the programmed low limit P_000 . When the busbar fails, the low limit will be used as P_000+P_007 . It is advised to set this value to 8 volts.
8	Pre-synchronization delay	sec	3	This is the time after the genset phase voltage is within the limits (set with parameters P_002 and P_003) and the synchronization checking is enabled.
9	Synchronization checking at parallel	-	0	0 : further synchronization checking is disabled when the SYNCH CHECK relay is energized. 1 : synchronization checking is always performed.

7. TROUBLESHOOTING

AC voltages or frequency displayed on the unit are not correct:

- Check engine body grounding, it is necessary.
- The error margin of the unit is +/- 3 volts.
- If there are faulty measurements only when the engine is running, there may be a faulty charging alternator or voltage regulator on the engine. Disconnect the charging alternator connection of the engine and check if the error is removed.
- If there are faulty measurements only when mains are present, then the battery charger may be failed. Turn off the battery charger fuse and check.

The unit is inoperative:

- The unit may be in sleep mode. Press any front panel key to wake-up.
- Measure the DC-supply voltage between terminals 5 and 6 at the rear of the unit. If OK, turn all the fuses off, then turn all the fuses on, starting from the DC supply fuse. Then test the unit again.

8. DECLARATION OF CONFORMITY

The unit conforms to the EU directives

-73/23/EEC and 93/68/EEC (low voltage)

-89/336/EEC, 92/31/EEC and 93/68/EEC (electro-magnetic compatibility)

Norms of reference:

EN 61010 (safety requirements)

EN 50081-2 (EMC requirements)

EN 50082-2 (EMC requirements)

The CE mark indicates that this product complies with the European requirements for safety, health environmental and customer protection.

9. TECHNICAL SPECIFICATIONS

Generator voltage: 300 V-AC max. (Ph-N)

Generator frequency: 0-100 Hz.

Busbar voltage: 300 V-AC max. (Ph-N)

Busbar frequency: 50/60 Hz.

Digital inputs: 0 - 30 V-DC. Internally connected to battery positive via 4700 ohm resistor.

DC Supply Range: 9.0 to 33.0 V-DC

Cranking dropouts: survives 0 V for 100ms.

Typical Standby Current: 100 mA-DC

Maximum Operating Current: 150 mA-DC (Relay outputs open)

Check Synch Relay Output: 10 A / 28V-DC

Operating temp.: -20°C (-4°F) to 70 °C (158°F).

Storage temp.: -30°C (-22°F) to 80 °C (176°F).

Maximum humidity: 95% non-condensing.

IP Protection: IP65 from front panel, IP30 from the rear.

Measurement category: CAT II

Air category: Pollution degree II

Dimensions: 72 x 72 x 52 mm (WxHxD)

Panel Cut-out Dimensions: 68x68 mm minimum.

Mounting: Front panel mounted with rear retaining steel spring.

Weight: 130 g (approx.)

Case Material: High Temperature ABS (UL94-V0, 100°C)

10. CONNECTION DIAGRAM

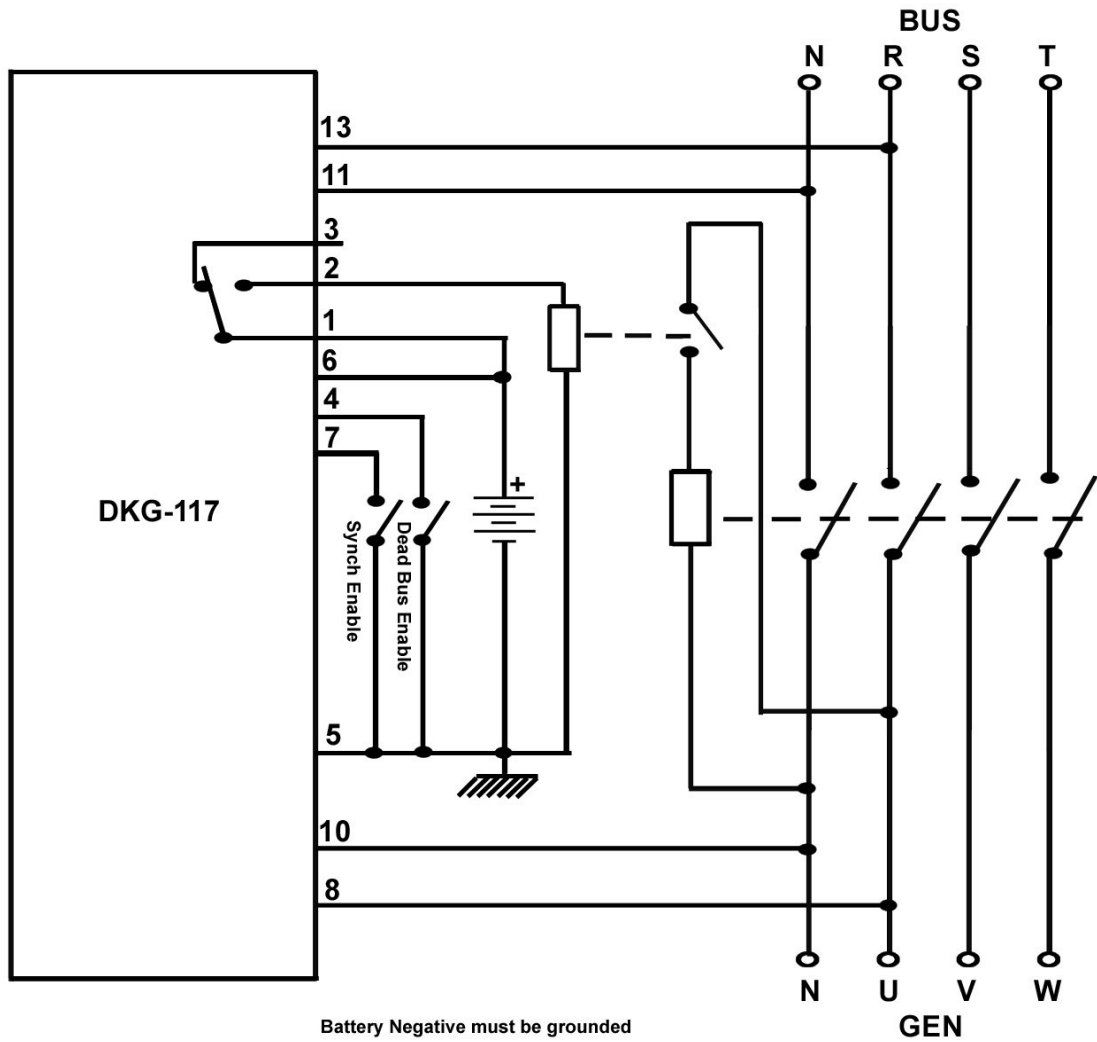

DATAKOMIRAQ e-mail : info@datakomiraq.com website : www.datakomiraq.com	Turkey Tel : 0090 212 533 3223 0090 212 533 2155	Baghdad Tel : 00964 770 641 71 57 (Eng. Salam) 00964 770 263 85 85 / 07901 326 302
--	---	--