

Operation manual for micro annular gear pumps
mzr-11508, mzr-11508X1



HNP Mikrosysteme GmbH
Bleicherufer 25
D-19053 Schwerin (Germany)
Telephone: +49 385/52190-301
Telefax: +49 385/52190-333
E-mail: info@hnp-mikrosysteme.de
<http://www.hnp-mikrosysteme.de>

Last update: July 2013

Impressum

Original instructions

Copyright
HNP Mikrosysteme GmbH
Bleicherufer 25
D-19053 Schwerin

All rights, including translation, reserved.

Without prior explicit written permission of HNP Mikrosysteme GmbH no part of this manual may be, copied, reproduced or processed.

This manual has been prepared with care. HNP Mikrosysteme does assume no liability for any errors in this manual and resulting consequences. Likewise, no liability is assumed direct or subsequent damages arising from an incorrect use of the devices.

While using micro annular gear pumps, the relevant standards regarding the specifications of this manual have to be followed.

Subject to change without notice.

Contents

1	General Information	4
1.1	Application scope of the pumps	4
1.2	Pump Model Designation	5
1.3	Technical data of the micro annular gear pumps m zr-11508	6
1.4	Measurements	7
1.5	Flow charts	8
1.6	Technical data of the motor of m zr-11508	10
1.7	Technical data of the motor of m zr-11508X1	12
2	Safety	14
2.1	Labelling of instructions in the operating manual	14
2.2	Staff qualification and training	14
2.3	Dangers from non-compliance with safety instructions	14
2.4	Safety-conscious work	14
2.5	Safety instructions for the operator	15
2.6	Safety instructions for maintenance, inspection and assembly work	15
2.7	Unauthorised conversions and spare parts manufacturer	15
2.8	Improper modes of Operation	15
2.9	General safety instructions	15
3	Transportation and Storage	17
3.1	Shipping	17
3.2	Transportation	17
3.3	Interim storage	17
4	Description of the micro annular gear pump	18
4.1	Operating principle of the micro annular gear pump	18
4.2	Construction	20
4.3	Construction materials	20
4.4	Fluidic connectors	21
5	Optional modules	22
5.1	Fluidic seal module	23
5.2	Heat insulation module	26
5.3	Heating module	27
5.3.1	Electric heating module	27
5.3.2	Fluidic heating- and cooling module	28
5.4	Heating device „JETmicro“	29
6	System integration	30
6.1	Check before installation	30
6.2	Mounting of the micro annular gear pump	30

6.3	General instructions for the assembly of the liquid supply network	30
6.4	Assembly instruction for tubing and accessories	31
6.5	Filter selection and use	33
7	Motion Controller	34
7.1	Operation with Controller S-HV	34
7.2	Operation with Controller S-HP-E	37
7.3	Operation with Controller S-BL	42
7.4	Operation with Controller S-HP-M	44
7.5	Operation with Controller S-HP (Option)	48
8	Start Up / Shut Down	51
8.1	Preparing for operation	51
8.2	Startup of the micro annular gear pump	51
8.3	Flushing procedure after use	51
8.4	Shutdown of the micro annular gear pump	54
8.4.1	Conservation	56
8.4.2	Dismantling of the system	57
8.5	Problem shooting	58
8.6	Return of the micro annular gear pump to the manufacturer	58
9	Software »Composer« and »Elmo Studio« (Option for S-HP-E)	59
9.1	Use application of CD	59
9.2	Creating a new application	60
9.3	Adjustment of controller parameter	63
9.4	Operation of micro annular gear pump with RS-232 interface	67
9.5	Operation of micro annular gear pump as stand alone application	68
9.6	Problems and their removal with controller S-HP-E	69
10	Software »Motion Manager« (Option for S-BL)	70
10.1	Direct drive control	70
10.2	Programming of the control	72
10.2.1	Transfer of a mcl file to the drive	73
11	Software »EPOS UserInterface« (Option for controller S-HP-M)	76
11.1	Startup Wizard for mzs-11508	76
11.2	Adjustment the control parameters	78
11.3	Direct drive control	80
11.4	LED Status	81
12	Software »EPOS« (Option for S-HP)	82
13	Problems and their removal	84

14	Accessories for microfluidic systems	86
15	Non-liability clause	86
16	Service and maintenance	86
17	EC Directive	87
17.1	Electromagnetic Compatibility (EMC)	88
17.1.1	EMC Directive and Standards for controller S-BL	88
17.1.2	Information on use as intended	89
18	Declarations of conformity	90
19	Service, maintenance and warranty.	95
20	Contact persons	96
21	Legal information	97
22	Safety information for the return of already employed micro annular gear pumps and components	98
22.1	General information	98
22.2	Declaration of liquids in contact with the micro annular gear pump	98
22.3	Shipment	98
23	Declaration of media in contact with the micro annular gear pump and its components	99
24	Supplement	100

1 General Information

This operating manual contains basic instructions to be followed during integration, operation and maintenance of a mzi[®] micro annular gear pump. For this reason it is necessary to read it carefully before any handling of the device. The present manual should always be kept at the operation site of the micro annular gear pump.

In case assistance is needed, please indicate the pump type visible on the housing.

1.1 Application scope of the pumps

The micro annular gear pumps described in this manual are suitable for continuous delivery and discrete dosage of water, watery solutions, solvents, methanol, oils, lubricating liquids, paints and varnishes as well as many other liquids.



If you intend to treat any aggressive, poisonous, or radioactive liquids, you must conform to safety measures as according to the regulations in force. Any project concerning handling of corrosive liquids should be previously discussed with the pump manufacturer.



The micro annular gear pumps *must not* be used for invasive medical applications, in which the liquid having had contact with the pump is re-introduced to the body.



Micro annular gear pumps exclusively are provided for use in the industrial area. A private use is excluded.



The micro annular gear pumps *must not* be used in aircrafts and spacecrafts or other vehicles without prior consent of the manufacturer.



Data concerning resistance of the pumps to the manipulated liquids have been elaborated according to the best of HNPM's knowledge. However, operating parameters varying from one application case to another, no warranty for this information can be given.



Information given in this manual does not release the customer from the personal obligation to check the integrity, correct choice and suitability of the pump for the intended use. The use of the micro annular gear pumps should be conform with technical norms and regulations in force.

If you wish to receive more information than comprised in this operating manual please contact directly HNP Mikrosysteme.

1.2 Pump Model Designation

This manual is valid for the micro annular gear pump m zr-11508 and m zr-11508X1, manufactured by HNP Mikrosysteme GmbH, Bleicherufer 25, D-19053 Schwerin, Germany.

The bottom line of this manual shows the issue and date of issue of this operating instruction.

1.3 Technical data of the micro annular gear pumps mzr-11508

	mzr-11508	mzr-11508X1
		
Constructive Specifications		
Displacement volume	192 µl	192 µl
Measurements (L x W x H)	309 x 108 x 124 mm	265 x 108 x 124 mm
Weight	approx. 8 kg	approx. 6 kg
Internal volume	8,5 ml	8,5 ml
Material case	stainless steel 1.4404, 1.4435 (316L)	stainless steel 1.4404, 1.4435 (316L)
Material rotor	tungsten carbide Ni-based	tungsten carbide Ni-based
Material bearing	tungsten carbide Ni-based	tungsten carbide Ni-based
Shaft seal	graphite-reinforced PTFE, spring Alloy C276 (2.4819)	graphite-reinforced PTFE, spring Alloy C276 (2.4819)
Static seals	FPM (fluoroelastomer), optional: EPDM, FFPM	FPM (fluoroelastomer), optional: EPDM, FFPM
Fluid connections	3/8" NPT internal thread, lateral	3/8" NPT internal thread, lateral
Technical data		
Flow rate	0,192 – 1152 ml/min (= 69,1 l/h)	0,192 – 1152 ml/min (= 69,1 l/h)
Smallest dosage volume	30 µl	30 µl
Operating pressure range	0 – 40 bar (by Viskosity 1 mPas) 0 – 100 bar (by Viskosity 16 mPas)	0 – 30 bar (by Viskosity 1 mPas) 0 – 30 bar (by Viskosity 16 mPas)
Max. inlet pressure	10 bar	10 bar
Viscosity range	0,5 – 150.000 mPas	0,5 – 50.000 mPas
Precision	< 1 %	< 1 %
Pulsation	6 % (theoretical)	6 % (theoretical)
Operating temperature	-5 ... +60 °C (120 °C*)	-5 ... +60 °C (120 °C*)
Ambient temperature	-5 ... +50 °C	-5 ... +50 °C
Store temperature	5 ... +40 °C	5 ... +40 °C

caption: * Differing specifications on request

table 1

Technical data of the micro annular gear pump head mzr-11508 and mzr-11508X1

Warning

The material properties of a liquid (e.g. viscosity, lubricating property, particle content, corrosiveness) impacts the technical data and the lifetime of pumps. Under appropriate conditions the characteristic values may be increased or decreased.

Warning

If you intend to operate the pump out of the range of the above given specification, please consult the manufacturer. Modifications may be necessary to ensure successful operation. Otherwise the pump or the system may be damaged seriously.

1.4 Measurements

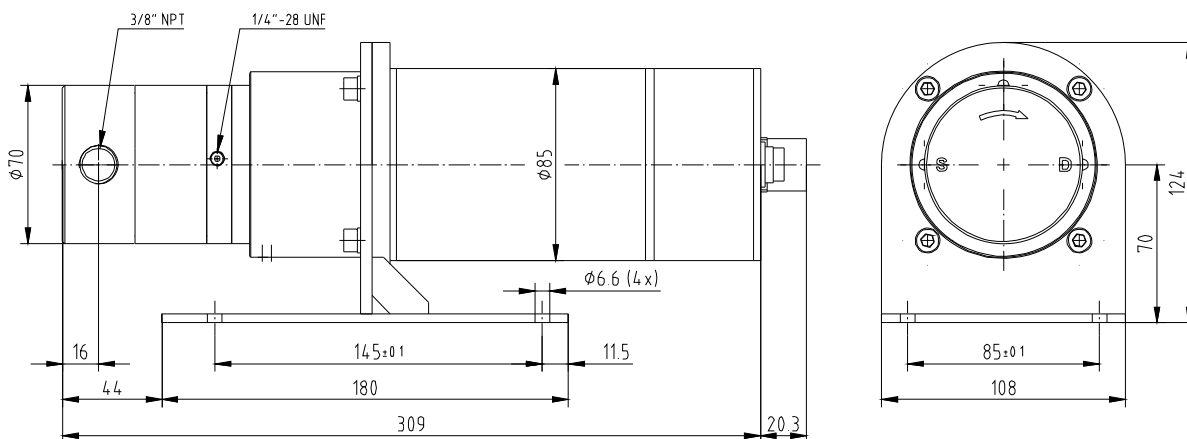

figure 1 Dimensions of the micro annular gear pump mzr-11508

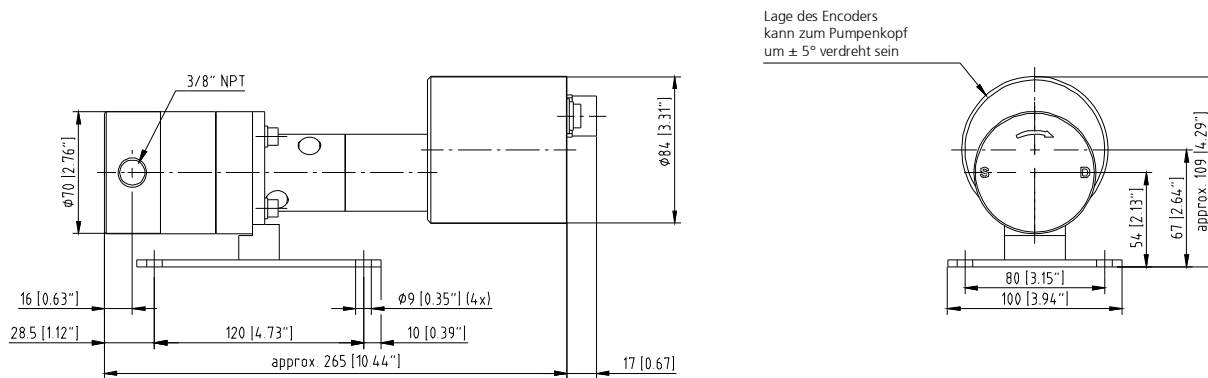

figure 2 Dimensions of the micro annular gear pump mzr-11508X1

1.5 Flow charts

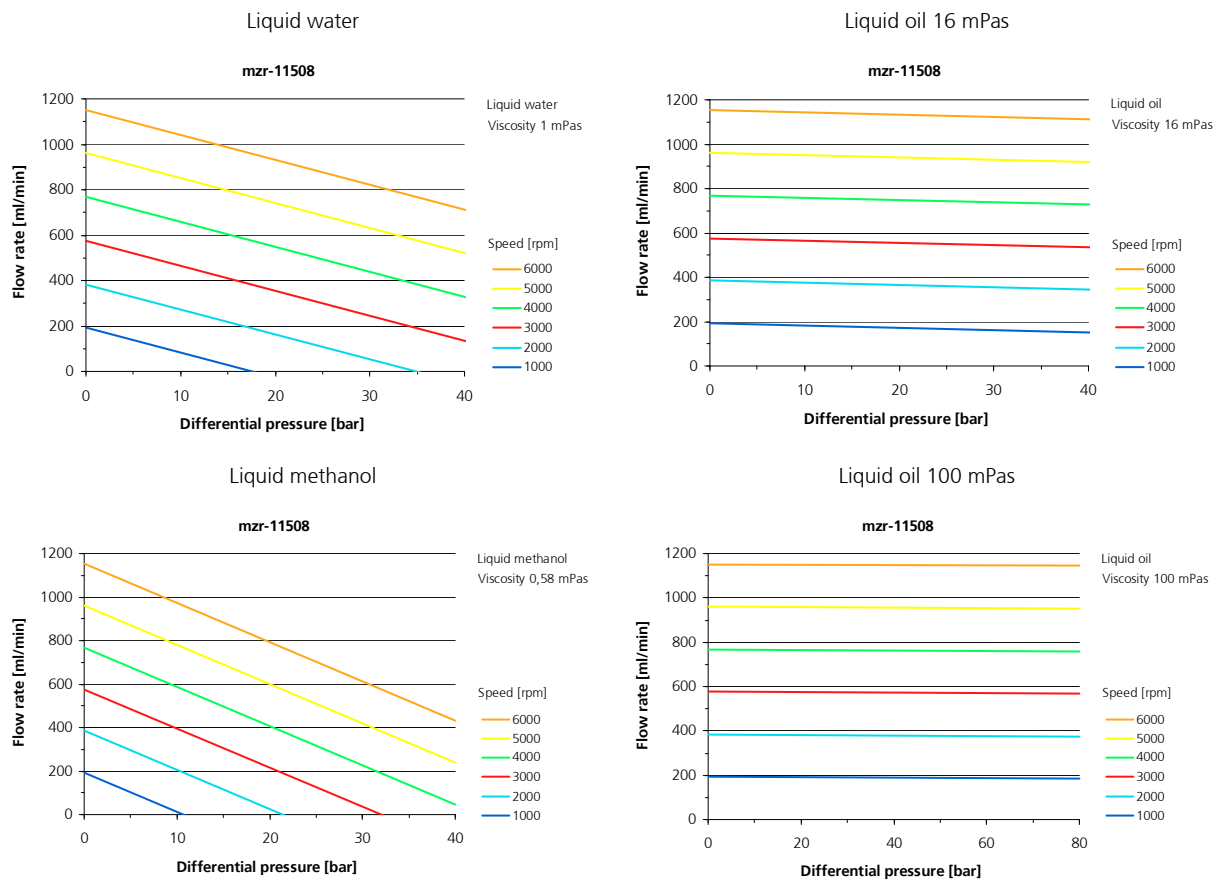
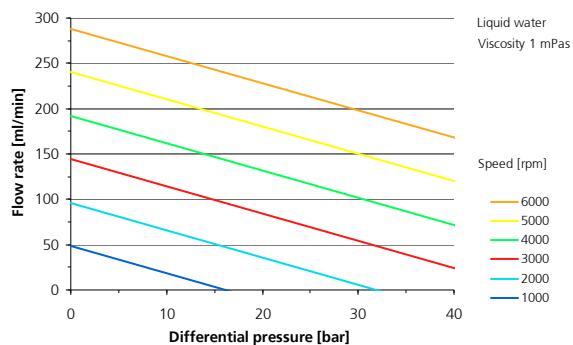
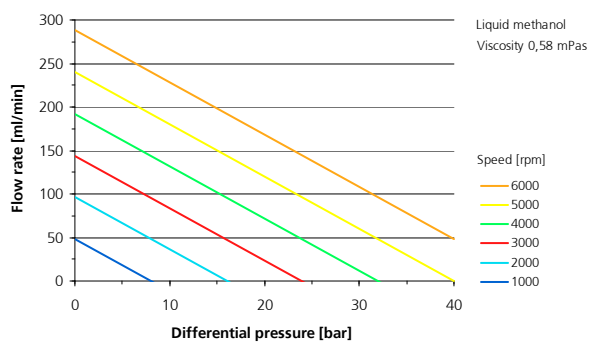

figure 3 Flow charts of the micro annular gear pump mzr-11508

Liquid water



Liquid methanol



Liquid oil, 16 mPas

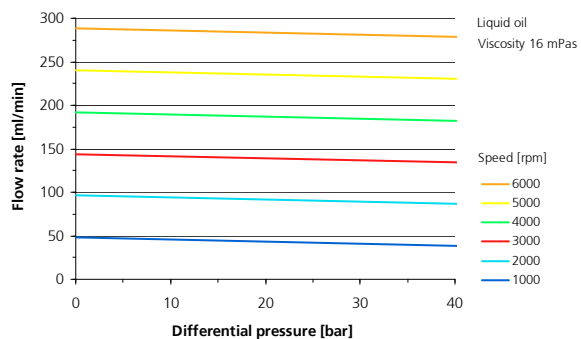

Liquid oil, 100 mPas

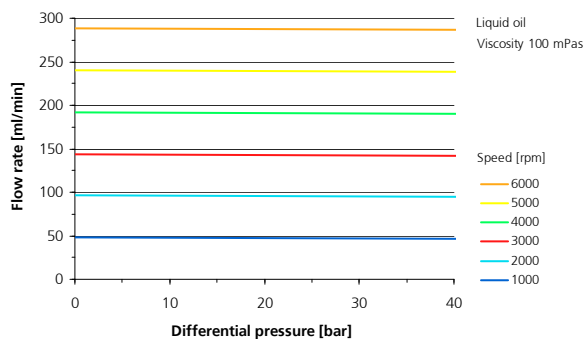

1.6 Technical data of the motor of mzr-11508

The micro annular gear pump mzr-11508 is provided with an actuator equipped with a 2 pole brushless DC-motor. The DC motor uses a high dynamic and is recommendable for programmed dosage operations of the micro annular gear pump. With a control unit it is possible to manage lower speed ranges down to 1 RPM. The accuracy of dosage can be achieved better than 0.5 %. The connection of the motor to a control unit is simple.

Data of capacity	
Nominal voltage	42 V DC
Max. continuous current	10 A
Assigned power rating	386 W
Max. Stall torque	500 mNm
Encoder	HP, Typ HEDL 5640
Cycles per revolution and channel	500
Operation range	1 – 6.000 rpm
Max speed by 24 V	4.000 rpm
operation range 42 V	7.000 rpm
Terminal inductance, phase-phase	275 µH
Protection class	IP 54
Weight	3,1 kg
Male socket for motor supply	Binder series 623 Type: 99-4637-20-06
Female cable connector for motor supply	Binder series 623 Type: 99-4636-00-06
Male socket for Encoder/Hall sensor	Lumberg Type: SFV 120
Female cable connector for Encoder/Hall sensor	Binder series 423 Type: 99-5130-15-12
length of the cable	3 m lengthen to max. 10 m

table 2 Technical data of the motor

Pin	Description
1	Motor phase A
2	n.c.
3	Motor phase B
4	n.c.
5	Motor phase C
6	n.c.

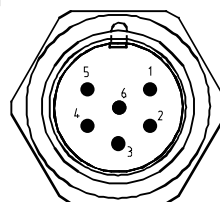

table 3 Pin configuration of the motor supply

Pin	Description
A	Encoder voltage +5 V
B	Encoder/Hall sensor GND
C	Encoder channel A
D	Encoder channel A neg.
E	Encoder channel B
F	Encoder channel B neg.
G	Encoder channel I
H	Encoder channel I neg.
J	Hall sensor voltage +5 V
K	Hall sensor A
L	Hall sensor B
M	Hall sensor C

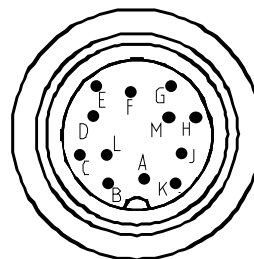

table 4 Pin configuration of the motor connector (Encoder/Hall)

wire colour	Description
brown	Motor phase A
green	Motor phase B
white	Motor phase C
black	screen (optional)

table 5 Motor supply cable 3 poles

wire colour	Description	pin Controller S-HV
red	Encoder voltage +5 V	6
pink	Hall sensors voltage +5 V	6
yellow	Encoder channel B	7
green	Encoder channel A	8
blue	Encoder/Hall sensor GND	9
brown	Hall sensor A	10
grey	Hall sensor B	11
white	Hall sensor C	12
black	screen	earth screw

table 6 Encoder/Hall sensors cable 8 poles with controller S-HV



The encoder channel A and B are change together on the controller S-HV!

1.7 Technical data of the motor of mzr-11508X1

The micro annular gear pump mzr-11508X1 can alternatively be driven with a brushless DC-motor with analog hall sensors. It is characterized by higher dimensions and a wider speed range, which covers entirely the speed range of the micro annular gear pump and shows a longer service life than a brushed DC-motor.

Performance parameters	
Nominal voltage	36 V
Max. continuous torque	191,9 mNm
Power	201 W
No-load speed at 9 V	10,450 rpm
Max. continuous current	6.29 A
Terminal resistance, phase-phase	0.445 Ω
Terminal inductance, phase-phase	143 μH
Speed	1 – 6000 rpm
Ambient temperature	-30 ... +125 °C
Type of Hall effect sensor	analog

table 7 Technical data of the brushless DC-motor

pin	Description
1	motor phase A
2	n.c.
3	motor phase B
4	n.c.
5	motor phase C
6	n.c.

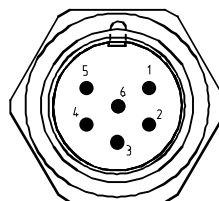

table 8 Pin configuration of the motor supply

wire colour	Description
brown	motor phase A
green	motor phase B
white	motor phase C

table 9 Cable 3 poles of the motor supply

pin	Description
A	Hall sensor GND
B	Hall sensor sensor voltage +5 V
C	Hall sensor A
D	Hall sensor B
E	Hall sensor C

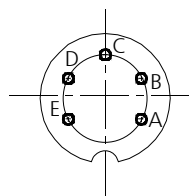

table 10 Pin configuration of the hall sensor connector

wire colour	Description
blue	Hall sensor GND
red	Hall sensor voltage +5 V
brown	Hall sensor A
grey	Hall sensor B
white	Hall sensor C

table 11 Motor cable 5 poles

Function	Connection	Color
Hall sensor	A	green
Phase	A	brown
Hall sensor	B	blue
Phase	B	orange
Hall sensor	C	gray
Phase	C	yellow
Voltage	+5 V	red
Mass	GND	black

table 12 Pin configuration of the motor (cable version)





Please notice that the brushless DC motors must imperatively be operated with an adapted control unit! The micro annular gear pump m zr-11508X1 can be delivered for this purpose with optional control units S-BL.

2 Safety

Comply with the general safety instructions listed in this safety section and also with the special safety instructions listed under the other main sections.

2.1 Labelling of instructions in the operating manual

The safety instructions are listed in this operating manual which, if not complied with, can cause danger, are specially labelled by

Danger symbol		Non-compliance poses danger for persons.
High voltage symbol		Non-compliance poses danger of electrical shock.
Warning symbol		Non-compliance poses a risk to the machines

The name plate mounted on the pump must be complied with and be maintained in a clearly readable condition.

2.2 Staff qualification and training

The operational, maintenance, inspection and assembly staff must evidence the appropriate qualifications for these works. Areas of responsibility, competencies and monitoring of the staff must be precisely regulated by the operator. If the personnel do not have the necessary knowledge, they must be trained and instructed accordingly. This can be implemented, if necessary, by the manufacturer / supplier on behalf of the machine operator. In addition, the operator must ensure that the content of this operating manual is fully understood by the personnel.

2.3 Dangers from non-compliance with safety instructions

Non-compliance with safety instructions can pose a danger not just to personnel, but also to the environment and machinery. Non-compliance with the safety instructions can lead to the loss of all claims for compensation.

In detail, non-compliance can cause the following dangers (examples):

- Failure of important machine/system functions
- Failure of prescribed methods for maintenance and servicing
- Danger to persons from electrical, mechanical and chemical effects
- Danger to the environment from escaping hazardous substances

2.4 Safety-conscious work

The safety instructions listed in this operating manual, the applicable national regulations for accident prevents and all internal working, operating and safety regulations of the operator must be complied with.

2.5 Safety instructions for the operator

- If hot or cold machine parts pose any danger, these parts must be protected on site against contact.
- Leaks (e.g. from the shaft seal) of dangerous conveyed goods (e.g. explosive, toxic, hot) must be guided away in such a manner that no danger is present for persons and the environment. Legal requirements must be complied with.
- Danger posed by electrical energy must be excluded

2.6 Safety instructions for maintenance, inspection and assembly work

The operator must ensure that all maintenance, inspection and assembly work is carried out by authorised and qualified specialist personnel, who are sufficiently familiar with this operating manual.



In general, work on the machine should only be implemented when it is at a standstill. The procedure described in this operating manual to stop the machine must be complied with in full.



Pumps or aggregates that convey media hazardous to health must be decontaminated. Immediately after work is complete, all safety and protection equipment must be remounted/restarted.



Before commissioning, the points listed in the Initial start-up section must be noted.

2.7 Unauthorised conversions and spare parts manufacturer

Conversions or modifications to the machine are only permitted following consultation with the manufacturer. Original spare parts and accessories authorised by the manufacturer ensure safety. The use of other parts may annul the liability for any resulting consequences.

2.8 Improper modes of Operation

The operating safety of the delivered machine is only ensured by its correct use as per chapter 1 in this operating manual. The limit values given in the manual must not be exceeded in any case.

2.9 General safety instructions



Skilled personnel may only do *mounting* and *initial operating* of micro annular gear pumps.



The pump can achieve *high pressures*. Use only the fluidic connections included in the delivery and be sure, that *fittings* and *tubes* are *permissible* and *specified* for these pressures.



In order to decrease the pressure, provide the system with a *pressure control valve* directing the excess liquid to the storage tank or back to the suction side. In the case of blockage of the pressure side the operating pressure can multiply, this can lead to the damage of downstream components.



The micro annular gear pump is highly precise manufactured. Any kind of contamination on the inside of the pump can cause damages. Therefore, we may ask you, to ensure yourself, that all fluidic leading parts are absolutely free from any kind of dirt, dust or any other particles, as these impurities may affect the function of the pump.



For operating of the micro annular gear pump, the use of filters with a pore size of 10 µm or smaller is required.

Warning

To connect the tubes of the pump remove the transport plugs and adapt them to the fittings, which are found in the delivery volume (see: assembly instructions for fluidic connections).



Pay attention to the *correct assembly* of your *fluidic connections* on the micro annular gear pump head, to keep up the indicated *flow direction*. Should you intend to use the pump in reverse operation modus, we may ask you to contact one of our Applications Consultants at HNP Mikrosysteme, as this kind of operation is not possible in every range of application.



If you intend to use *aggressive, corrosive or poisonous, etc. pumping media*, you are obligated to take care of the appropriate safety precautions in accordance of law and regulations.



Information about *media constancy* is given by best knowledge of HNP Mikrosysteme. According to the variations of parameter referring to the variety applications, we are *not able* to take a *warranty* upon these specifications.



The *rotary shaft seals* used in the micro annular gear pump avoid in standard operation the leaking of media from the micro annular gear pump. Micro annular gear pumps are »technically sealed«, but *not hermetic sealed*, so that gases may escape from the pump or lead into the pump.



Take measures of precaution to avoid damages on close by equipment and avoid pollution of the environment, in case of disengagement. Be careful to assemble the micro annular gear pump, so that disengaging fluidic media may not leak into the motor or the control unit in case of malfunction.



In standstill, the medium in the pump may float in direction of the drop of pressure through the pump. If necessary provide *back pressure valves* (see: accessories).

Warning

Avoid in any case *dry running* of your *micro annular gear pump* as this may especially damage the seals. A short phase of dry running when setting the pump into operation is negligible.

Warning

Do not disassemble the micro annular gear pump in case of malfunction; contact our service personnel of HNP Mikrosysteme immediately to be helped.



Protect the micro annular gear pump and the electric actuator from *shock and at zero impact*.



The actuators may be protected against *moisture, dust and perspiration*.



The *permitted electrical data* of the actuators may *not be exceeded*. Notice that especially *the accurate set polarity* of the distribution voltage is required, if not the control unit can be destroyed.

Warning

The *surface temperature* of the *actuators* can exceed 60°C (140°F) in *full load*. You might want to *provide protection* to avoid *accidental contact*, which will cause burns on your skin.

3 Transportation and Storage

3.1 Shipping

The pumps are shipped from the factory in such a manner that they are protected against corrosion and against shocks.

In addition, inlets and outlets are plugged with protective plugs. This measure is necessary to securely prevent foreign bodies from penetrating into the pump's interior.

3.2 Transportation

To avoid transport damage, the transport packaging must be protected against shocks.

HNP Mikrosysteme guarantees that the shipped goods are in perfect condition at the time of delivery. The pumps must be immediately checked for transport damage once the pumps have been received. If damage is noted, the shipper responsible and the pump manufacturer must be informed immediately.

3.3 Interim storage

The following points must be obeyed for storing the pumps:

- Do not store the pumps in wet or damp rooms
- Protective plugs must be left screwed in
- Store temperature see according section 1.3 of this manual

4 Description of the micro annular gear pump

4.1 Operating principle of the micro annular gear pump

Micro annular gear pumps are positive displacement pumps. They contain two rotors, bearing slightly eccentrically to each other; an externally toothed internal rotor and an annular, internally toothed external rotor (see figure 4). Due to their cycloid indenting, the rotors remain interlocked at any time, forming during rotation a system of several sealed pumping chambers. As the rotors revolve around their offset axis, the pumping chambers increase on the induction (suction) side and simultaneously decrease on the delivery side of the pump (see figure 5). A homogenous flow is generated between the kidney-like inlet and outlet.

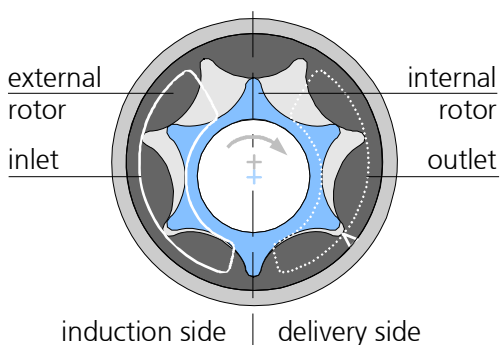

figure 4

Principle of the micro annular gear pump

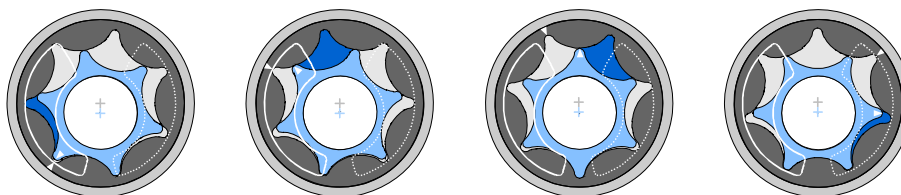

figure 5

Operating principle of the micro annular gear pump

Reciprocating and rotary pumps have a direct allocation to the fed amount of the displacement volume V_g of the pump and its actuator's number of revolutions n . The displacement volume describes the volume, which is theoretically fed with each revolution. The coherence of the flow rate referring to the formula (= volumetric flow rate) Q of the pump is:

$$Q = \eta_{Vol} \cdot V_g \cdot n$$

The volumetric efficiency η_{Vol} shows the relationship between the actual and the theoretical flow rate. The existing differences result from internal movement of the liquid during the operation.

Example: The pump head mzs-11500 has a displacement volume of 192 μl . On the assumption that the volumetric efficiency is 100%, the flow rate at a speed of 3000 RPM would be 576 ml/min, according to the above formula. The table 13 shows theoretical flow rate values depending on speed expressed in ml/min and l/h.

RPM	Q [ml/min]	Q [l/h]
100	19,2	1,15
500	96	5,76
1000	192	11,52
2000	384	23,04
3000	576	34,02
4000	768	46,08
5000	960	57,60
6000	1152	69,12

table 13

Theoretical flow rate of the micro annular gear pump mzs-11508

The pressure, which the pump has to generate, is given by the construction of the fluidic system and the results of the hydrostatic pressure and the hydraulic resistants (given by tubes, contractions etc.).

The viscosity of the pumping medium has an important influence on the volumetric efficiency. The volumetric efficiency increases with higher viscosity according to the smaller disengagement through the gaps of the pump.

Cavitation is an effect, which can result in a specific ceiling speed. The reason for this is the static pressure reaching the steam pressure of the liquid in the inlet port of the pump. In this state an increase of speed does not result in an increased flow rate. The formation of gas prevents a sufficient feeding of the pump. With increasing viscosity of the liquid (e.g. > 10.000 mPas), the ceiling speed is lower.

The specific feature of the mzs-pumps is their highly precise design, as well as the guarantee of high accumulator pressure and high accuracy in flow rate and dosage. Therefore, space width and transverse space width of the rotors as well as the interspace to the adjacent case parts are in the range of just a few micrometers. This precision is the condition to achieve a volumetric efficiency in the range of approx. 100 %.

4.2 Construction

The micro annular gear pump consist of the pump head, coupling assembly, motor and bracket (see figure 6).

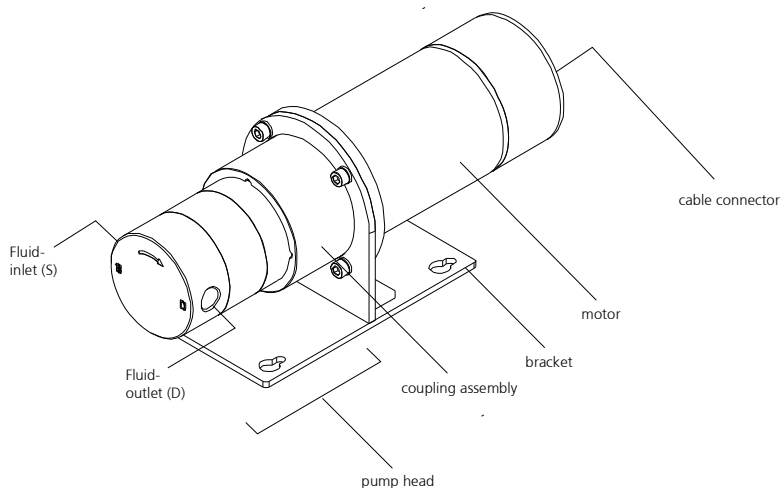

figure 6 Design of the micro annular gear pump mZR-11508

4.3 Construction materials

Components	
Case	stainless steel 1.4435 (316L)
Rotor, shaft, bearing	tungsten carbide Ni-based
Shaft seal	graphite-reinforced PTFE, spring Alloy C276 (2.4819)
Static seals	FPM (fluoroelastomer), optional: EPDM, FFPM

table 14 Materials of the components

The resistance of the construction materials to the delivered liquids should be verified by the operator for each individual application. Pumps handling non-lubricating liquids have shorter service lives.

4.4 Fluidic connectors

The micro annular gear pump head has an inscription on the front side (see figure 7). The liquid inlet connection is marked with the letter »S«, the liquid outlet connection with the letter »D«. An arrow indicates the inherent turning direction of the shaft.

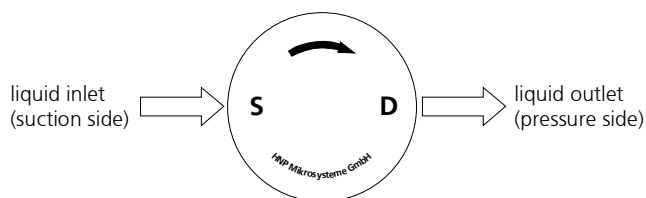

figure 7

Indication of the turning direction and fluidic connections on the front of the micro annular gear pump

The pump head has two inner threads for the connection of tube fittings. The pump head is available either in a version for lateral connections with 3/8" NPT fittings.

Sealing plugs are inserted into the holes for the fluidic connections as protection against contamination during delivery. The sealing plugs have to be removed before assembly of the fluidic connectors. If the fluidic connectors are disassembled, please re-seal the threads with the cleaned sealing plugs as protection against particles.

5 Optional modules

The spectrum of applications of the high performance micro annular gear pump series may be expanded by using different additional modules. The modules allow for special applications, which could otherwise not be accomplished with a standard pump version. The modules may be combined with each other and with almost all available pump heads and motor versions.

- *Fluidic seal module* prevents possible chemical reactions between the delivered liquid and the surrounding environment
- *Thermal insulation module* extends the operating temperature range of the pump by protecting the motor from overheating
- *Heating module* enables to regulate the temperature of the fluid-containing parts of the pump

The configuration of a given pump version should in each case be discussed with consideration to the specific requirements of the application. *Additional* customized modules may be designed on demand.

5.1 Fluidic seal module

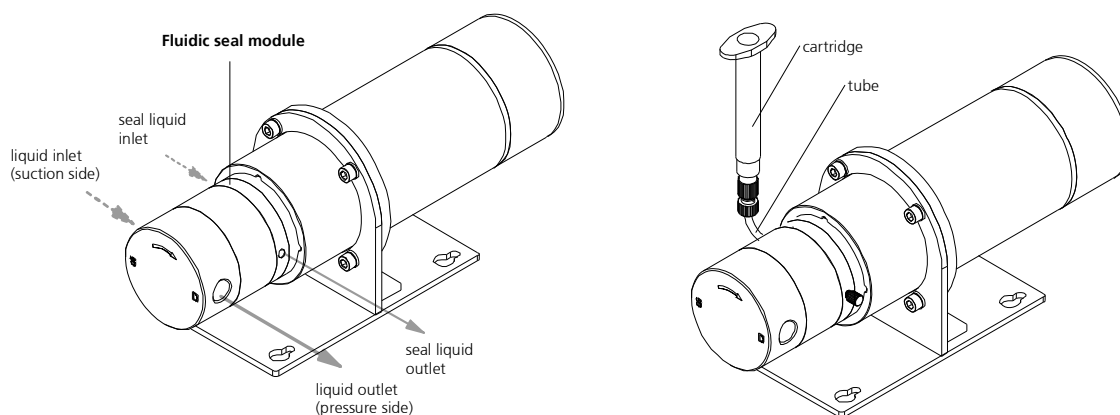

Figure 8 Design of the micro annular gear pump with fluidic seal module

The role of the fluidic seal module is to prevent moisture and oxygen in the surrounding atmosphere from penetrating into the pump. This eliminates the risk of unwanted chemical reaction between the atmospheric gases and the handled liquid (such as for example the crystallization reaction). The module limits at the same time the possibility for the manipulated liquids to escape from the pump.

The function of the fluidic seal module

The shaft sealing employed in the high performance micro annular gear pump is designed in a way that allows for the formation of a boundary layer in which the delivered liquid comes into contact with the surrounding environment. Small amounts of water vapor and oxygen may penetrate through the protective boundary liquid film into the pump. The fluidic seal module enables to control this influx - only a chosen and compatible liquid may come into contact with the delivered liquid. The fluidic seal module prevents also the inverse movement of the liquid - from the pump to the environment - which could otherwise not be excluded.

With the fluidic seal module, a second sealing is added to the existing shaft sealing. A cylindrical chamber with input and output openings displaced by 180° is located between the two seals (see figure 9). When the chamber is filled with an appropriate sealing liquid, the manipulated liquid does not enter into contact with water vapor and oxygen, but dilutes at a small ratio in the sealing liquid. The dilution ratio depends on the existing pressure relations and drops with increasing viscosity.

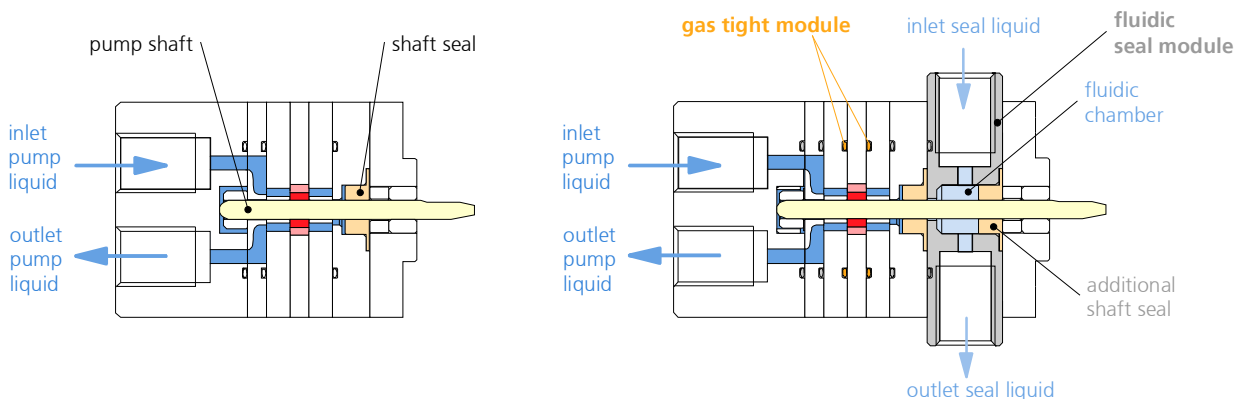

figure 9 Pump head without the fluidic seal module

Pump head with the fluidic seal module

Pump operation with the fluidic seal module

Only liquids compatible with the delivered liquid may be used as sealing liquids. That means no liquids that could possibly react with the delivered liquid should be employed. The composition of the sealing liquid should be determined by the operator.

While filling up the fluidic seal chamber a particular attention should be paid to proper venting of the chamber through the two openings featuring a 1/4 - 28 UNF thread. These openings are slightly shifted downwards and upwards to facilitate the degassing of the sealing chamber (see figure 11). The chamber is filled through the bottom opening. The sealing liquid should be filled in so long, till it flows free of air bubbles out of the top opening. Now the inlet should be screwed down.

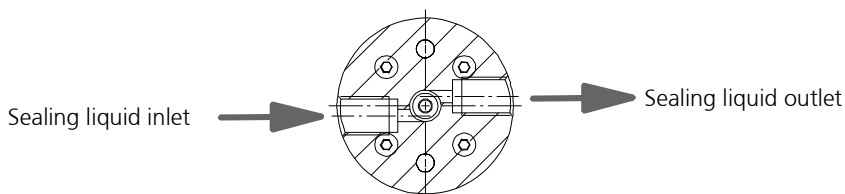

figure 10

Sectional view of the fluidic seal module

A cartridge may be used to supply the sealing liquid to the chamber (see figure 9). In special cases compressed air may be applied to the sealing liquid in order to enhance the sealing function. The sealing chamber may be flushed.



Make sure that enough sealing liquid is supplied to the fluidic seal chamber in order to prevent any penetration of air and water vapor to the module.



If the fluidic seal chamber is empty, the pump should immediately be stopped. Dry operation may lead to shaft seal damage.

In case the pump is not installed in the standard way (pump name read horizontally), it is possible to shift the outlet and inlet openings of the pump. However an appropriate supply of the sealing liquid should still be ensured and all presence of air bubbles within the fluidic seal chamber should be avoided.

Use of the fluidic seal accessories



The fluidic seal set is mounted at the bottom inlet (see figure 10).

During assembly it is important to check if the ferrule is tightly attached to the tube and that the tube is tightly screwed to the inlet of the fluidic chamber.



figure 11

Assembly of the fluidic seal accessories (standard version)

Liquid supply set in stainless steel version (as separate accessory)

Stainless steel liquid supply set is available on request. The use is the same as with the standard version. The liquid supply is done by a glass syringe.



figure 12

Stainless steel set for the fluidic seal module

5.2 Heat insulation module

The heat insulation module enables to deliver hot liquids up to temperatures of 120° C (248 °C). It comprises thermally insulating coupling components made of plastic (PEEK) located between the pump and the drive. The drive should not be exposed to overheating. For this reason the heat transfer from the pump to the drive should be limited. An additional thermal barrier is provided by the plastic motor housing. If the surrounding temperature rises, the pump is working over a longer period or the manipulated liquid features a high temperature, convection cooling of the motor is recommended.

5.3 Heating module

5.3.1 Electric heating module

The electric heating module enables active heating of the pump head up to 120° C (248 °C) operating temperature. The heating module consists of a heating jacket covering the pump head and a thermal element type J. Depending on the pump size, the thermal element will be integrated on the pump head in different ways. In order to adjust the temperature of the pump head, an additional heat regulating device may be delivered.

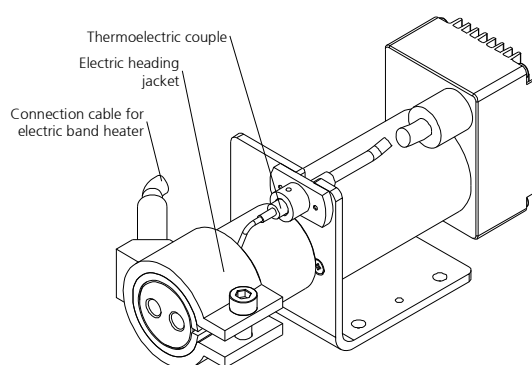

figure 13

Micro annular gear pump m zr-2905 with the electric heating module



Before connecting the heating jacket and the thermal element to the power supply, please observe the following technical data.

Thermal element	
Type	MT-1.5
Thermal element	Type J (Fe-CuNi IEC 584) alternativ: Type L (Fe-CuNi DIN 43710)
Temperature measuring range	0 to 400 °C
Diameter of the sensing device	1.5 mm
Material	V4A (1.4541)
Cable length	0,8 m
Heating jacket	
	m zr-11508
Voltage	230 VAC
Power output	600 W
Diameter	70 mm
Width	approx. 50 mm
Cable length	0,8 m

table 15

Technical data of the electric heating module

5.3.2 Fluidic heating- and cooling module

The fluidic heating and cooling module permits active heating or cooling of the pump head in the operating temperature range from -20 °C (-4 °F) to a maximum of 120 °C (248 °F). The module consists of a double casing covering the pump head and a thermoelectric couple type J, whose mode of integration varies depending on the pump size. Oil, water, superheated steam or adapted cooling liquids may be used as thermal liquids. If you are not sure, which heat transfer liquid is the best adapted in your case, HNP Mikrosysteme will help you find the suitable one. The inlet for the heat transfer liquid is situated at the back (beveled) and the outlet is in the front (see figure 14).

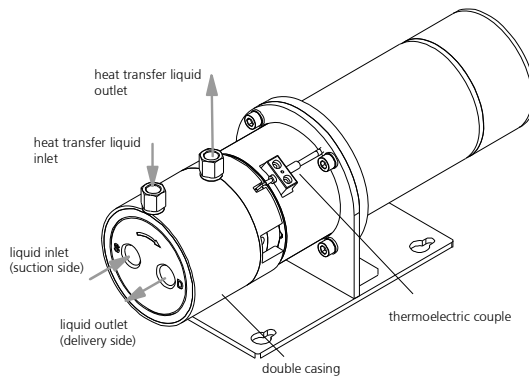

figure 14

Micro annular gear pump with integrated fluidic heating- and cooling module



This heating module is not certified for use in areas exposed to explosion hazards!



Before connecting the liquid supply, please observe the following technical data! The maximal pressure of the heat transfer liquid should not exceed 10 bar.

Thermal element	
Type	MT-1.5
Thermal element	Type J (Fe-CuNi IEC 584) alternativ: Type L (Fe-CuNi DIN 43710)
Temperature measuring range	0 to 400 °C
Diameter of the sensing device	1.5 mm
Material	1.4541
Double jacket	
	mzr-11507
Length	82 mm
Diameter	85 mm
Double jacket material	stainless steel 316L
Inlet	2xG1/8"
Operating temperature range	-20 to 120 °C
Max. pressure	max. 10 bar
Flow rate	max. 0.5 l/min

table 16

Technical data of the heating and cooling module

5.4 Heating device „JETmicro“

The heating device „JETmicro“ has been designed for use with the electric heating module (see chapter 5.3.1).

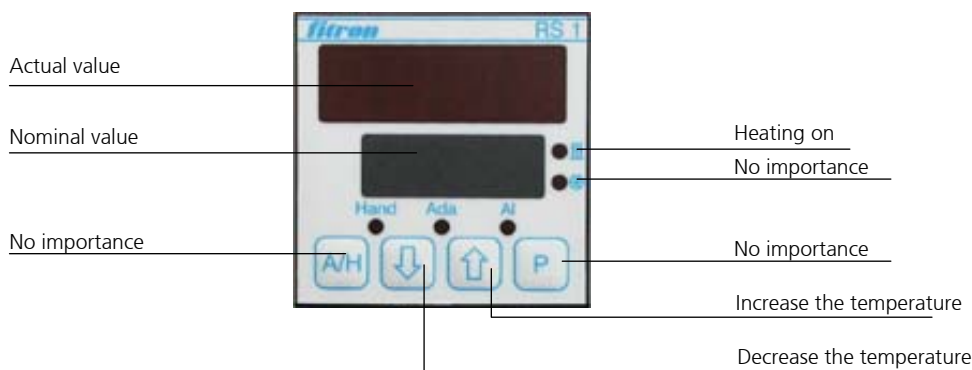



Hand: Blinks during temperature set in the manual input mode

Ada: Ada display blinks during the automatic control adjustment

AL: Alarm display – not configured, no importance

Actual value display:

- OPEN** = sensor failure
- cLL** = sensor reverse polarity
- cHH** = actual temperature value transgressed

With  or  the nominal temperature may be set.

Power supply

Shock-proof plug, 3 m long, 90-230 VAC

Electrical connection

10-pole bush insert, 16 A/250 V

	Heating		Sensor	
	L	N	+	-
Zone 1	1	6	2	7
Zone 2 (Option)	4	9	5	10

table 17

Pin configuration of the heating device

6 System integration

6.1 Check before installation

Inspect the pumps for potential damage during the shipment (see chapter 3.2).

Please check, if the right pump type has been delivered, as according to the following points:

- Compatibility with the delivered liquid
- Viscosity range
- Pump performance (displacement volume, dosage volumes, operating pressures)
- Operating temperature range



If you notice any difference between the required and the delivered pump type, please contact HNP Mikrosysteme. Do not put the pump into operation without prior approval.

6.2 Mounting of the micro annular gear pump

The micro annular gear pump is mounted on an angle support with M5 screws. The favored mounting position of the micro annular gear pump is horizontal. However, if the pump has to be operated vertically, the motor must be located above the pump head in order to prevent the liquid from entering into the motor.

Warning

Install the pump in such a way that in case of failure no liquid can enter the motor or controller.



Take precautions that in case of leakage no surrounding objects or environment will be damaged.



Install the micro annular gear pump only in places that fulfill the required conditions for safe pump operation.



The motor must be protected against humidity, dust or sweat.

6.3 General instructions for the assembly of the liquid supply network



Please always cut the tubing at a right angle with an adapted hose cutter. If metal tubes are used, an intensive cleansing procedure will be necessary. After machining the tubing has to be cleansed and flushed throughoutly. The smallest piece of swarf within the liquid delivery system may cause failure of the micro annular gear pump.



Please note that correct integration of the tubing with the pump head is a necessary condition to ensure the right direction of flow. If you wish to operate the pump in a reverse direction, please contact HNP Mikrosysteme, since it is not possible in every case.



In order to protect the interior of the pump from pollution, the pump heads are delivered with protective plugs. They should be put on when the pump is at a standstill.



For the best performance the suction tube should be as short as possible and have a large internal diameter.

Warning

In most cases the pump should be operated with a filter featuring pores that do not exceed 10 µm. The filter protects the pump from particles and dirt.

6.4 Assembly instruction for tubing and accessories

Particles or soiling can block or impair the function of the micro annular gear pump.

Warning

Please check that all wetted parts of the fluidic system are clean. Clean these parts in case before mounting the pump.

Please check whether there are swarfs in the screw connections, pollution remaining in reservoirs or soiling in valves, pipe work or filters.

Assembly of the tubing and piping system

1. Please cut the tubing rectangular with a hose cutter. If metal pipes are used an intensive cleaning procedure is necessary. After machining the pipes have to be cleaned and flushed very carefully. Smallest swarfs within the fluidic system can cause failure of the micro annular gear pump.
2. Connect the fittings with the tubing respectively the pipe work according to the attached installation instruction.



Please note that the correct assembly of tubes respectively pipes with the pump head is a necessary condition to secure the right direction of flow. When you want to operate the pump in reverse direction please contact HNP Mikrosysteme since this is not possible in any application.

3. The thread of the fitting should be wrapped with 2-3 layers of PTFE tape and screwed in the NPT thread (see table 18). First manually, then tightened with ½ to ¾ wrench turns.



Clean the internal and external screw threads leaving no residues.

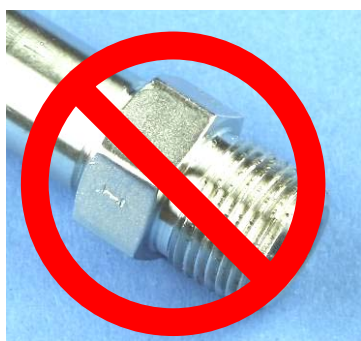

Make sure the internal and external screw threads are not dented or deformed.



Wrap the PTFE tape around the screw thread clockwise beginning with the second pitch of screw thread..



The PTFE tape should be wrapped tightly around the screw thread approx. two times (720°).



Cut the PTFE tape off and wind the end of the tape tightly around the screw thread.



The PTFE tape should not stick out over screw thread because pieces can be cut off and get into the system.

table 18

Use of PTFE Tape

4. The suction line should be installed ascending to the pump for better degassing. The suction line should be designed as short as possible. The inner diameter of the suction line should be large to guarantee good priming of the liquid. At the planning of the pipe system take care of possibilities for degassing.
5. Operate the micro annular gear pump always with a filter with a pore size of 10 μm or smaller. The filter prevents that particles or solids penetrate into the pump what can cause major damage.
6. Avoid dry running of the pump. Make sure that the liquid flow is not interrupted.

6.5 Filter selection and use

In majority of cases it is recommended to integrate a filter on the suction side of the micro annular gear pump to ensure its secure operation. The recommended filter pores or mesh size should not exceed 10 µm. The penetration of particles or swarf that could cause a blockage or damage to the pump can only be avoided by using an adapted filter.

HNP Mikrosysteme offers a choice of standard filters covering a broad spectrum of applications. You may count on our assistance for the selection of the most suitable one.

In order to select the best adapted filter, such operating parameters as flow rate, viscosity and degree of pollution of the liquid will be needed. An increase in at least one of the mentioned terms will require the use of a bigger filtering element or the pressurization of the delivered liquid. In case no suitable filter for high viscosity liquid can be found, it is possible to use a filter with slightly larger pore size. Prior discussion with HNP Mikrosysteme is here recommended. A filter with larger pores is still better than no filter at all. Alternatively an already filtered liquid may be used.

Warning

Because filters have a large internal volume, it is recommended to fill in the filter and the suction tube with already filtered liquid in order to avoid dry operation of the pump during the startup.

Warning

Please control regularly the filtering elements for pollution. Cleanse regularly the filter or replace it with a new one. A polluted filter may considerably decrease the volumetric efficiency of a pump. Furthermore, because of the cavitation effects dosage imprecision and even pump damage may occur.

Warning

A too small filter (too little filtering surface) may considerably decrease the volumetric efficiency of the micro annular gear pump. What is more, because of the cavitation effects dosage imprecision and even pump damage may occur.

7 Motion Controller

Without a motion control unit you cannot start the micro annular gear pump mzr-11508!

7.1 Operation with Controller S-HV

We deliver the micro annular gear pump with the controller S-HV. Over this controller can be control the speed of the motor and the flow rate of the pump.

Electrical parameter of the controller S-HV			
Power supply	U_B	48 (11 – 70)	V
Max. continuous Current	I_{cont}	10 ^{*)}	A
Max. peak Current	I_{max}	20 ^{*)}	A
Velocity Range		50...6000 ^{*)}	rpm
Inputs			
Set value	Input resistor	20	k Ω
	Voltage signal	± 10	V
Encoder signals	Channel	A, B	
	Logic level	TTL	
Enable	Frequency range	max. 100	kHz
	Logic level	low 0...0,5/high 8...30	
Display	Enable	high active	
	2-colour LED	green: Ready, red: Error	
Outputs			
Current monitor „Monitor I“	Output voltage range	± 10	V
	proportional factor	0,5	V/A
	Output resistor	10	k Ω
Speed monitor „monitor n“	Output voltage range	± 10	V
	proportional factor	0,5	V/A
	Output resistor	10	k Ω
Supervision output Ready	Input voltage range	max. 30	V
	current	< 20	mA
Technical Data			
Temperature range	operation	-10 ... +45 °C	
	storage	-10 ... +80 °C	
Humidity range	non condensing	20 ... 80 % rel. hum.	
Dimensions	L x B x H	180 x 100 x 40 mm	

*) Values are different for each pump type

table 19

Technical Data of the controller S-HV

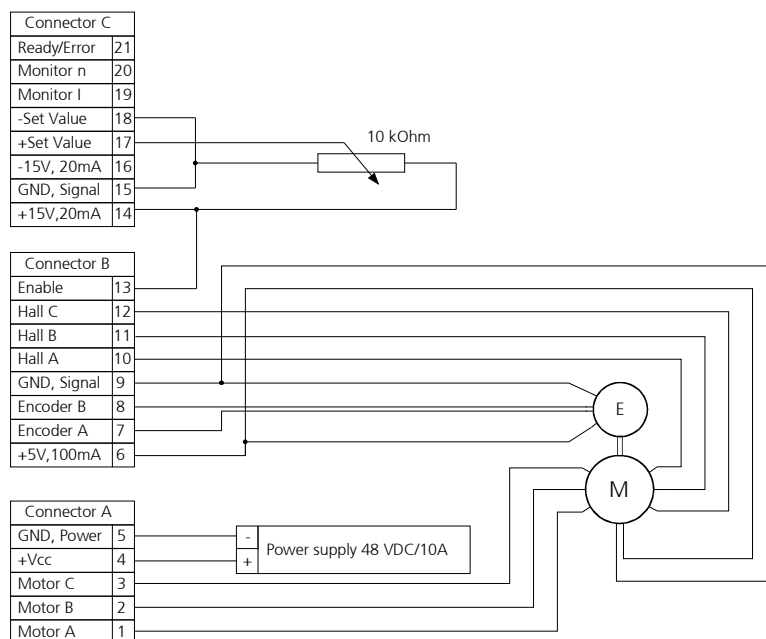

Figure 15 Connection plan with controller S-HV and micro annular gear pump mzs-11508

Initial operation procedure

1. Connect the motor cables with an motor control unit (see Figure 15).
2. Connect the DC- power supply with 48 V to the control unit. Check for correct polarity. False connecting may cause severe malfunction or even destroy the electronic of the motor.
3. Check the adjustment of the internal potentiometer.

potentiometer	function	potentiometer position
P1	Gain course	5 %
P2	Gain fine	0 %
P3	maximum speed at set value of 10 V	100 %
P4	Current limitation	100 %
P5	Offset	50 %

table 20 Internal potentiometer position

4. To avoid in any case dry running of the micro annular gear pump we recommend ensuring steady media supply.
5. Programming the control unit or turn the potentiometer in 0 position that the pump not rotate (0 rpm)
6. Switch on in the DC-power supply and start the micro annular gear pump.

Notice:

By an installation with the control unit SCA-B4-70-10 please read the operating instruction of the control unit! The speed range can change with the jumper on the control unit. The motor of the micro annular gear pump mzs-11508 have 2 pole! You can configure the control unit to control the speed with external potentiometer! You can configure the control unit to control the speed with external potentiometer! The speed range is to be set by jumper J10 and J11. One of four speed ranges is to be set.

Jumper(s)	max. speed
J10 and J11	2500 rpm
J10	5000 rpm
J11	10000 rpm

table 21

Speed range



Skilled personnel may only do *mounting* and *initial operating* of micro annular gear pumps.



Check for correct polarity. False connecting may cause severe malfunction or even destroy the electronic of the motor.



Avoid in any case *dry running* of your *micro annular gear pump* as this may especially damage the seals.

Filling the pump with liquid before you start the pump!

For filling use a syringe!

7.2 Operation with Controller S-HP-E

We deliver the micro annular gear pump mzr-11508 with the controller S-HP-E. This programmable control unit enables to adjust speed for constant flow rates or the position of the motor for the dosage of constant amounts of liquid.

Electrical parameter of the controller S-HP-E			
Power supply	U_B	48 (20 – 55)	V
Max. continuous Current	I_{dauer}	10 ^{*)}	mA
Max. peak Current	I_{max}	20 (< 1s) ^{*)}	mA
Speed range		30...6,000 ^{*)}	rpm
Max. motor power		800 ^{*)}	W
Interface RS-232	after RS-232 standard	9600 Baud, 8 Bit, 1 Stop-Bit, RxD, TxD, GND (keine Handshake Signale)	
Interface CAN	after DSP 301, DSP 402		
Software	Composer, Elmo Studio		
Input			
Digitale Eingänge	programmable	10	
	Voltage signal	12 – 24 (High)	V
Analoge Eingänge	Input resistor	2	
	programmable	± 10, 14 bit Auflösung	V
Encodersignale	Voltage signal	A, /A, B, /B, I, /I	
	Channel	max. 5	MHz
Hallsignale	Frequency range	A, B, C	
	Channel	0 – 1 (Low) 2,5 – 5 (high)	V
Output			
Digital output	programmable	5	
Voltage +5 V Encoder	Voltage	5	V
	Max. Current	200	mA
Voltage +5 V Hall sensors	Voltage	5	V
	Max. Current	30	mA
Voltage +5 V Auxiliary	Voltage	5	V
	Max. Current	200	mA
Technical Data			
Temperature range	operation	0 ... +40 °C	
	storage	-20 ... +85 °C	
Humidity range	non condensing	20 ... 90 % rel. hum.	
Dimensions	L x B x H	150 x 105 x 25.4 mm	
Weight		IP20	
Temperature range		640 g	

*) Values limited in the control unit with corresponding software

table 22

Technical Data of the controller S-HP-E

The control unit S-HP-E permits an easy startup of the pump with following interfaces:

- Power supply over connector
- Interface RS-232 over connector alternative CAN Bus over separate connector
- Prepared separate cable for the motor and the encoder/hall sensor with electrical connectors (useful for initial setup and an example for installation in control cabinet)
- Status display over LED.

Warning

When commissioning with the controller S-HP-E note the attached technical descriptions!

Warning

Follow the enclosed instructions!

Warning

Without a motion controller is the micro annular gear pump not set in operation!



Make sure that the polarity of the supplied direct current is correct, otherwise electronics will be damaged.

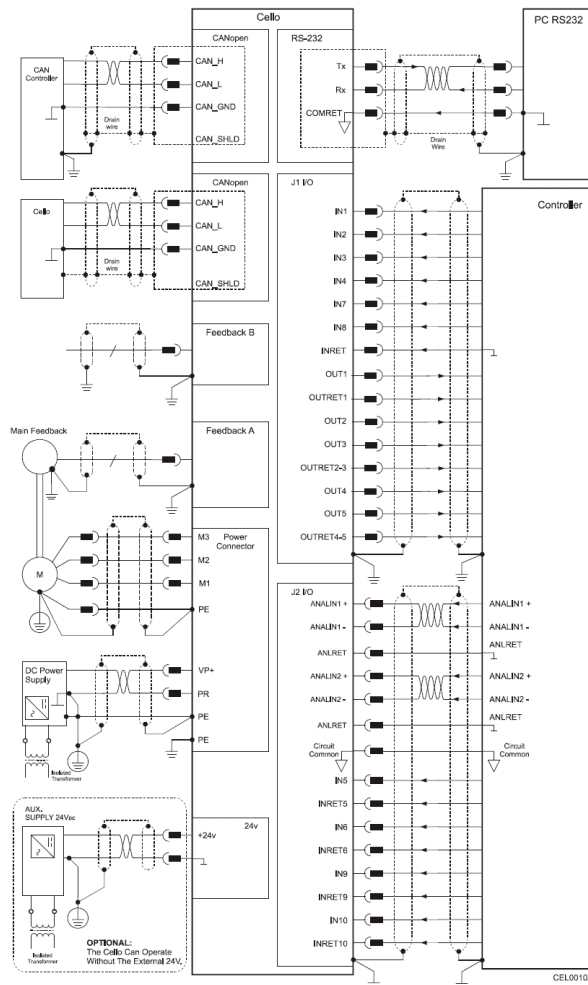

figure 16

Connection plan with controller S-HP-E

Initial operation

1. Connect the power cables with a motor control unit.

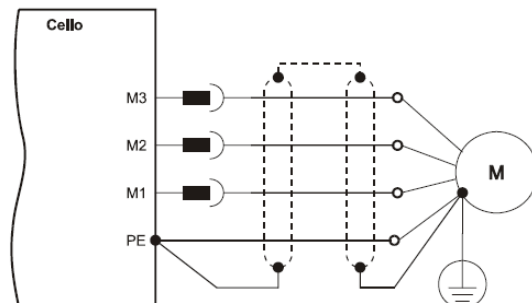

figure 17 Connection plan power cable

Connector Power & Motor S-HP-E	Cable LIY(C)Y 3 x 1,5 mm ²	Description	Connector 6 poles motor
M1	brown	Phase A	1
M2	green	Phase B	3
M3	white	Phase C	5
	yellow/green	screen	

table 23 Power cable

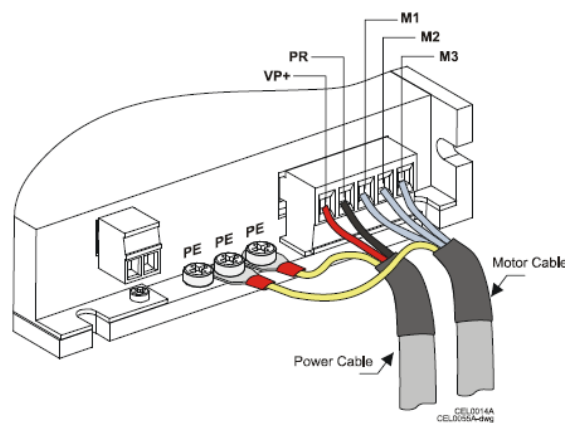

figure 18 Connecting the power cable

Connector Feedback S-HP-E PIN	Feedback Cable CBL-DFDBK	Cable LIY(C)Y 12 x 0,14 mm ²	Description	Connector 12 poles motor
1	green	white	Hall sensor C	M
10	yellow	grey	Hall sensor B	L
2	pink	brown	Hall sensor A	K
3	white	blue	GND	B
4	brown	red/pink	+5 V (Hall/Encoder)	A / J
5	orange	black	Encoder Channel A neg.	D
6	light-blue	green	Encoder Channel A	C
7	blue	red/blue	Encoder Channel I neg.	H
8	red	grey/pink	Encoder Channel I	G
14	black	purple	Encoder Channel B neg.	F
15	purple	yellow	Encoder Channel B	E
	grey	n.c.	no function	n.c.

table 24

Feedback Cable

Connector J1 S-HP-E PIN	Elmo I/O cable CBL-CELIO1	Signal	Function
1	orange	IN1	Programmable Input 1
2	light-blue	IN2	Programmable Input 2
3	purple	IN3	Programmable Input 3
8	black	IN8	Programmable Input 8
4	grey	OUT2	Programmable Output 2
5	pink	OUT3	Programmable Output 3
6	blue	IN4	Programmable Input 4
7	red	IN7	Programmable Input 7
9	white / yellow	INRET	General Input Return
10	white / red	OUTRET2-3	Programmable Output Return 2 + 3
11	yellow	OUT4	Programmable Output 4
13	green	OUT5	Programmable Output 5
12	white /black	OUTRET4-5	Programmable Output Return 4 + 5
14	brown	OUT1	Programmable Output 1
15	white	OUTRET1	Programmable Output Return 1

Tabelle 1

I/O cable J1

2. Connect the RS-232 port of the controller with a free serial interface of a PC. For this purpose use the delivered adapter cable.
3. To avoid in any case dry running of the micro annular gear pump we recommend ensuring steady media supply.
4. Connect the power supply of 48 VDC on the connector Power & Motor. False connecting may cause severe malfunction or even destroy the

electronic of the controller! After switch on of the power supply during the initial phase of the S-HP-E the green LED "power" light on.

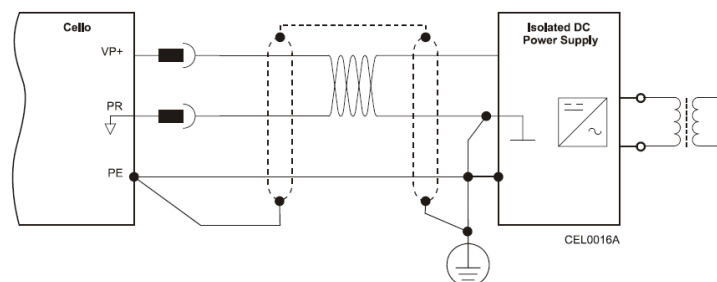

figure 19

Main power supply connection diagram



The power supply of the controller S-HP-E should be 48 VDC. With this power supply can be operated the micro annular gear pump with the entire speed range (see chapters 1.3 and 7.2).

5. You may now install the delivered software » Composer « as described in the chapter 9.

Remarks:

For problems with the initial operation read the included manual for detailed motion controller! Further documentations are also located on the enclosed CD.

7.3 Operation with Controller S-BL

The micro annular gear pump mzr-11508X1 with brushless DC motor and analog hall sensors as drive be delivered with the S-BL control unit. This programmable control unit enables to adjust speed for constant flow rates or the position of the motor for the dosage of constant amounts of liquid. On the delivered diskettes or CDs you will find a PC-program operating under Windows that enables to program such parameters as speed, acceleration and current consumption. The delivery package comprises also a null-modem cable for connection to a serial interface of a PC.

S-BL control unit			
Type of control unit		4-Q servo amplifier	
Nominal voltage	U	24	V
Power supply	U _B	12 - 30	V
Residual ripple		≤ 2 %	
Max. continuous output current	I _{continuous}	4,500*)	mA
Max. peak output current	I _{max}	6,000*)	mA
Speed range		10...5,900*)	rpm
Input No. 1	input resistance	5	kΩ
Nominal analog speed	voltage range	± 10	V
Nominal digital speed	PWM signal	low 0...0.5 / high 4...30	V
	frequency range	100...2,000	Hz
Input No. 2	Error signaling	max. U _B / 30 mA	
	no error	switched to GND	
	programmed as input	low 0...0.5 / high 3,5... U _B	V
Input No. 3	TTL - logic level	low 0...0.5 / high 3,5...30	V
	PLC - logic level	low 0...7 / high 12,5...30	V
Program memory		6,6	kBytes

*) Values limited in the control unit with corresponding software

table 25

Technical data of the S-ND control unit

The control unit permits an easy startup of the pump with:

- the possibility to connect the voltage supply to the delivered DIN socket
- the possibility to connect the voltage supply with screw clamps
- a 8-pole screw clamps connector assembly for the motor cable
- speed set with potentiometer
- analog voltage signal 0-10 V for speed control at the screw clamps
- 9-pole connection plug for the RS-232 interface
- error output with status LED, programmable also as trigger input with screw connections
- tumbler switch S1 for the connection of digital input No. 3 of the motor control unit

Startup with the S-BL control unit

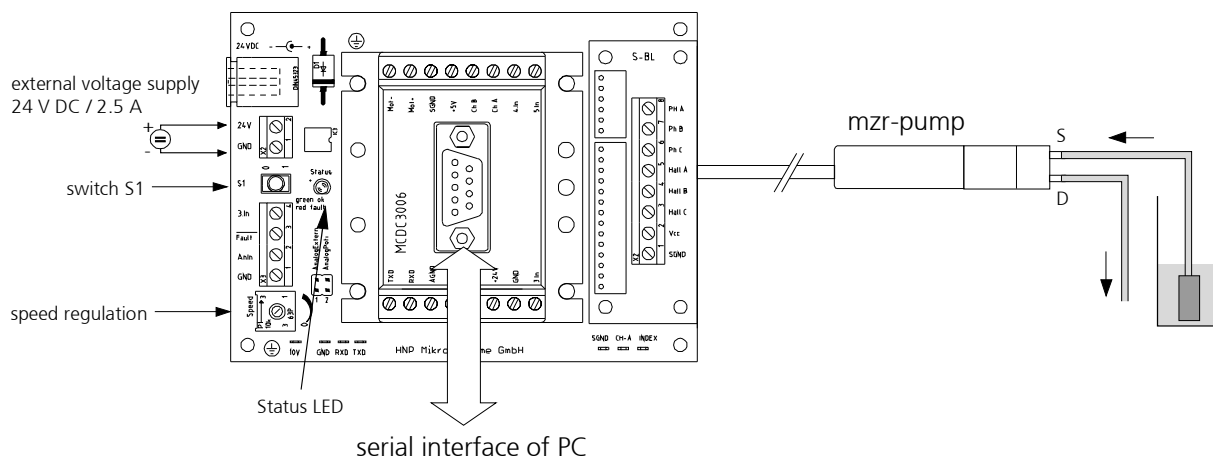

figure 20

Connection of the micro annular gear pump and the S-BL control unit

1. Connect the motor cable to connector of the S-BL control unit. The cable configuration is indicated in 1.7.
2. Connect the RS-232 port of the MCBL3006 with a free serial interface of a PC. For this purpose use the delivered 9-pole null-modem cable.
3. Put the potentiometer of the S-BL control unit to zero position by turning it clockwise to the limit stop.
4. Connect the voltage supply 24 VDC. This can be done with the integrated DIN connector or, alternatively the 2-pole screw clamp (24 V = »+«; GND = »-«). Pay attention to the correct polarity.
5. You may now install the delivered software »Motion Manager« as described in the chapter 9.



While connecting the DC voltage pay attention to the correct polarity, otherwise electronics may be damaged.

Remarks:

- It is possible to adjust speed of the micro annular gear pump with the potentiometer without the need to connect the serial interface.
- With the analog nominal value input (connection clamps »AnIn« and »GND«) it is possible to adjust speed of the pump with a standard signal 0-10°V. For this purpose it is necessary to plug the jumper on the S-BL control unit from the »AnalogPoti« to the »AnalogExtern«. The serial interface does not need to be connected.
- In case of an overcurrent error the green status LED on the S-BL control unit turns red
- The standard programs memorized in the motor control unit may be started with the tumbler switch S1. Basic sample programs are shown in the chapter 9. For more advanced programs please refer to the user manual for Motion Controller MCBL3006.

7.4 Operation with Controller S-HP-M

We deliver the micro annular gear pump mzs-11508 with the controller S-HP-M. Over this controller can be control the speed and the position of the motor for controlling of the flow rate and the dosage volume of the pump.

Electrical parameter of the controller S-HP-M			
Power supply	U_B	48 (11 – 70)	V
Max. continuous Current	I_{dauer}	10 ^{*)}	A
Max. peak Current	I_{max}	20 ^{*)}	A
Velocity Range		1...6,000 ^{*)}	rpm
Max. motor power		700	W
Interface RS-232	after RS-232 standard	9600 Baud, 8 Bit, 1 Stop-Bit, RxD, TxD, GND (no handshake signals)	
Interface CAN	after ISO/DIN 11898		
Software	EPOS UserInterface		
Input			
Digital Inputs	programmable	8	
	Voltage signal	9 – 24 (High)	V
	Input resistor	1,8	k Ω
Analog Inputs	programmable	2	
	Voltage signal	0 – 5, 10 bit resolution	V
Encoder signals	Channel	A, /A, B, /B, I, /I	
	Frequency range	max 1	MHz
Hall signals	Channel	A, B, C	
	Signal level	0 – 0,8 (Low) 2,9 – 6 (high)	
Output			
Digital output	programmable	4	
Voltage +5 V Encoder	Voltage	5	V
	Max. Current	100	mA
Voltage +5 V Hall sensors	Voltage	5	V
	Max. Current	30	mA
Voltage +5 V Auxiliary	Voltage	5	V
	Max. Current	$R_i = 1 \text{ k}\Omega$	
Technical Data			
Temperature range	operation	-10 ... +45 °C	
	storage	-40 ... +85 °C	
Humidity range	non condensing	20 ... 80 % rel. hum.	
Dimensions	L x B x H	150 x 93 x 27 mm	
Weight		330 g	

*) Values are different for each pump type

table 26

Technical Data of the controller S-HP-M

The controller enables the easy set-up of micro annular gear pump with the help of the following interfaces:

- Power supply over connector
- Interface RS-232 over connector alternative CAN Bus over separate connector
- Motor connections over separate connector
- Status display over LED.

Warning

When commissioning with the controller S-HP-M note the attached technical descriptions!

Warning

Without a motion controller is the micro annular ring pump not set in operation!



Make sure that the polarity of the supplied direct current is correct, otherwise electronics will be damaged.

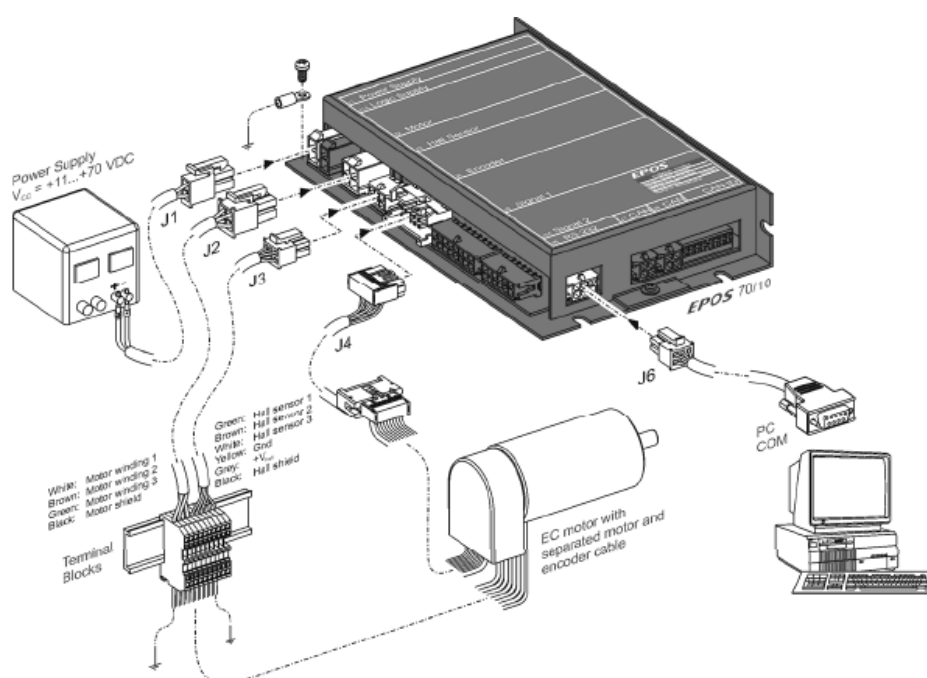

Figure 21

Minimum wiring for controller S-HP-M for micro annular gear mzs-11508

Initial operation

1. Connect the drive with the separate wires to the controller.

Connector J3 S-HP-M	Maxon Hall Sensor Kabel 275878	Cable LIY(CY) 12x0,14 mm ²	Description	12 poles Connector
5	grey	pink	+5 V	J
4	yellow	blue	GND	B
1	green	brown	Hall sensor A	K
2	brown	grey	Hall sensor B	L
3	white	white	Hall sensor C	M
6	black	n.c.		

table 27

Hall sensor cable

Connector J4 S-HP-M	Maxon Encoder Cable 275934	Twisted wire	Cable LIY(CY) 12x0,14 mm ² 2	Description	12 poles Connector
1	brown	Pair 1	n.c.		
2	white	Pair 1	red	+5 V	A
3	red	Pair 2	blue	GND	B
4	white	Pair 2	n.c.		
5	orange	Pair 3	purple	Channel B neg.	F
6	white	Pair 3	yellow	Channel B	E
7	yellow	Pair 4	black	Encoder Channel A neg.	D
8	white	Pair 4	green	Encoder Channel A	C
9	green	Pair 5	red/blue	Encoder Channel I neg.	H
10	white	Pair 5	grey/pink	Encoder Channel I	G
			yellow/green	screen	ground

table 28

Encoder cable



The encoder channels A and B are swapped against each other in the controller S-HP-M!

Connector J2 S-HP-M	Maxon Motorcable 275851	Cable LIY(CY) 3 x 1,5 mm ²	Description	6 poles Connector
1	white	brown	motor phase A	1
2	brown	green	motor phase B	3
3	green	white	motor phase C	5
4	black		Screen	

table 29

Motor supply cable

2. Connect the RS-232 port of the Controller (adapter cable of the controller) with a free serial interface of a PC. For this purpose use the delivered RS-232 adapter cable of the controller.

Connector	Twisted Wire	Description	Wires
1	Pair 1	EPOS RxD	yellow
2	Pair 2	EPOS TXD	white
3	n.c.		
4	Pair 1	GND	green
5	Pair 2	GND	brown
6		Screen	black

table 30

Connector of the Interface RS-232

3. Provide for a steady liquid supply to the pump in order to avoid dry operation of the device.
4. Connect the power supply of 48 VDC on the connector J1. False connecting may cause severe malfunction or even destroy the electronic of the controller! After switch on of the power supply during the initial phase of the S-HP-M the red LED "power" light on.



The power supply of the controller S-HP-M should amount to 48 VDC, since this supply voltage of the entire speed control range (see chapter 1.3) of the micro annular gear pump.

5. The pump may now be put into operation by using the software »EPOS UserInterface«.

Remarks:

- If there are problems with the initial operation read the attached detailed operating instructions for the controller.

7.5 Operation with Controller S-HP (Option)

We deliver the micro annular gear pump with the controller S-HP. Over this controller can be control the speed and the position of the motor for controlling of the flow rate and the dosage volume of the pump.

Electrical parameter of the controller S-HP			
Power supply	U_B	48 (11 – 70)	V
Max. continuous Current	I_{dauer}	10 ^{*)}	A
Max. peak Current	I_{max}	20 ^{*)}	A
Velocity Range		1...6000 ^{*)}	rpm
Motor inductance (minimum) by (50 kHz)		100	μ H
Communication interfaces	RS-232	9600	Baud
	CAN (CAN-Open)	ISO/DIN 11898	
Input			
Digital Inputs	programmable	4	
	Voltage signal	13 - 30	V
	Input resistor	5	k Ω
Digital Inputs	for lim. sw., home position	3	
Ouput			
Digital Outputs	programmable	4	
	current	< 500	mA
Digital Output "ready"		1	
	current	< 500	mA
Auxiliary voltage output I/O		24	V
Auxiliary voltage output for encoders	Voltage signal	5	V
	current	100	mA
Display	Input + Output + Status	4 + 4 + 4	
Operating system	EPOS		
Microprocessor	CPU MC 68332.25 MHz		
RAM	SRAM 2 * 32 kB		
ROM	EPROM 2 * 128 kB		
Technical Data			
Temperature range	operation	0 ... +40	$^{\circ}$ C
	storage	- 20 ... +85	$^{\circ}$ C
Humidity range	non condensing	20 ... 80 % rel. hum.	
Dimensions	L x B x H	190 x 100 x 40	mm
Weight		900	g

*) Values are different for each pump type

table 31

Technical Data of the controller S-HP

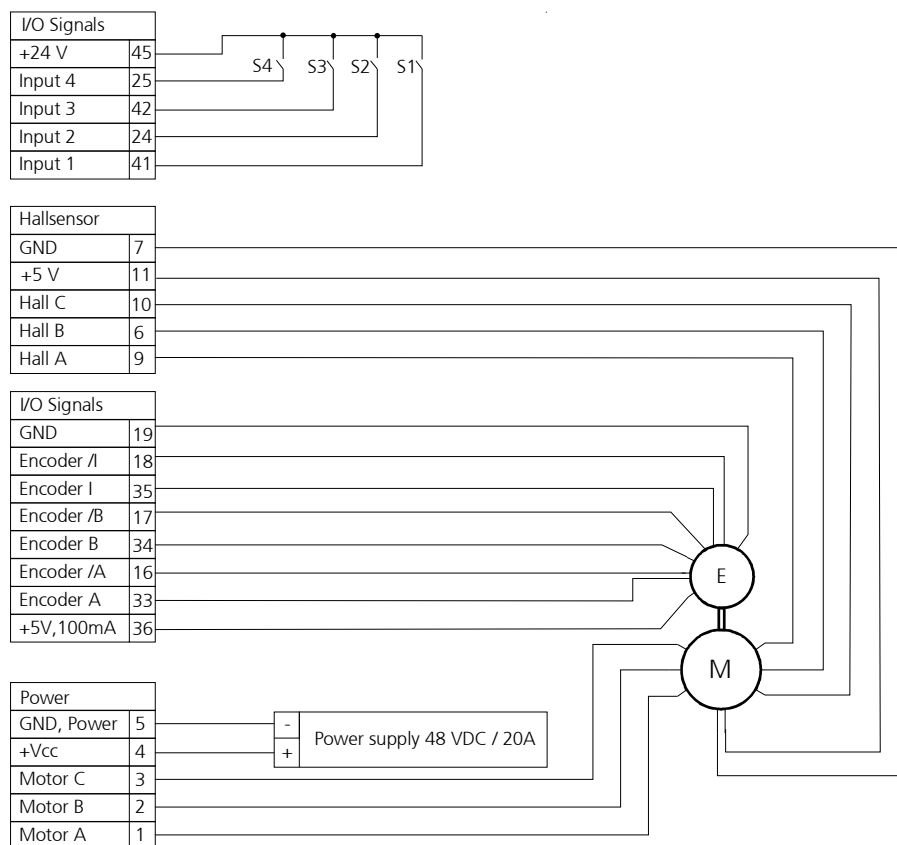

Figure 22

Connection plan with controller S-HP and micro annular gear pump mzr-11508

Initial operation procedure

1. Connect the motor cables with a motor control unit (see Figure 22).
2. Connect the RS232-Connector of the controller with a free serial interface of a PC. Here for use the 9-pin zero-modem cable, included in the delivery volume.
3. Connect the DC- power supply with 48 V to the control unit. Check for correct polarity. False connecting may cause severe malfunction or even destroy the electronic of the motor.
4. To avoid in any case dry running of the micro annular gear pump we recommend ensuring steady media supply.
5. Switch on in the DC-power supply and start the micro annular gear pump.
6. The micro annular gear pump can now be taken into service either by switching the switch S1 or by using the software »EPOS« delivered with (Installation see further down).



The Controller S-HP is programming with the program »continuous_flowrate_11508.m«! If you switch S1 the pump runs with approx. 3000 rpm and a flow rate of approx. 576 ml/min. If this parameter is not the best for the process, please change the parameter in the program!

Notice:



Skilled personnel may only do *mounting* and *initial operating* of micro annular gear pumps.



Check for correct polarity. False connecting may cause severe malfunction or even destroy the electronic of the motor.



Avoid in any case *dry running* of your *micro annular gear pump* as this may especially damage the seals. A short phase of dry running when setting the pump into operation is negligible.

Filling the pump with liquid before you start the pump!

For filling use a syringe!

8 Start Up / Shut Down

8.1 Preparing for operation

After the liquid supply system had been completed, please check once again the operating conditions of the micro annular gear pump as according to the following points:

- Are the inlet and outlet tubes correctly connected?
- Is the entire liquid supply system clean - that means free of particles, foreign bodies, pollution or swarf?
- Has a filter been installed on the suction side?
- Has a sufficient amount of the right liquid been supplied?
- The pump does not run the risk of a dry operation?
- The entire liquid supply system has been checked for leakage?
- Is it possible to stop the pump by an emergency switch if an unexpected malfunction occurs at the startup?

8.2 Startup of the micro annular gear pump

Switch on the voltage supply. The micro annular gear pump can now be put into operation by turning on the potentiometer knob or by sending a nominal external voltage signal.

Start the filling in of the pump at low or middle speed (1000 - 3000 rpm).

Warning

Avoid dry operation of the pump. The pump should be filled in before it is put to operation.

8.3 Flushing procedure after use

After each service the micro annular gear pump should be carefully flushed with a non-corrosive, filtered and particle-free flushing liquid (see table 32 and table 33). During flushing procedure the pump should operate at a speed of about 3000 rpm and if possible against a low pressure (that can be obtained by using a restrictor, a capillary or similar). The flushing liquid must be compatible with the delivered liquid and suitable for solving the remaining liquid rests. Depending on the application for example water, or isopropanol may be used. If you have doubts whether a particular liquid is suitable for this function or not, please ask the manufacturer of the liquid or HNP Mikrosysteme.

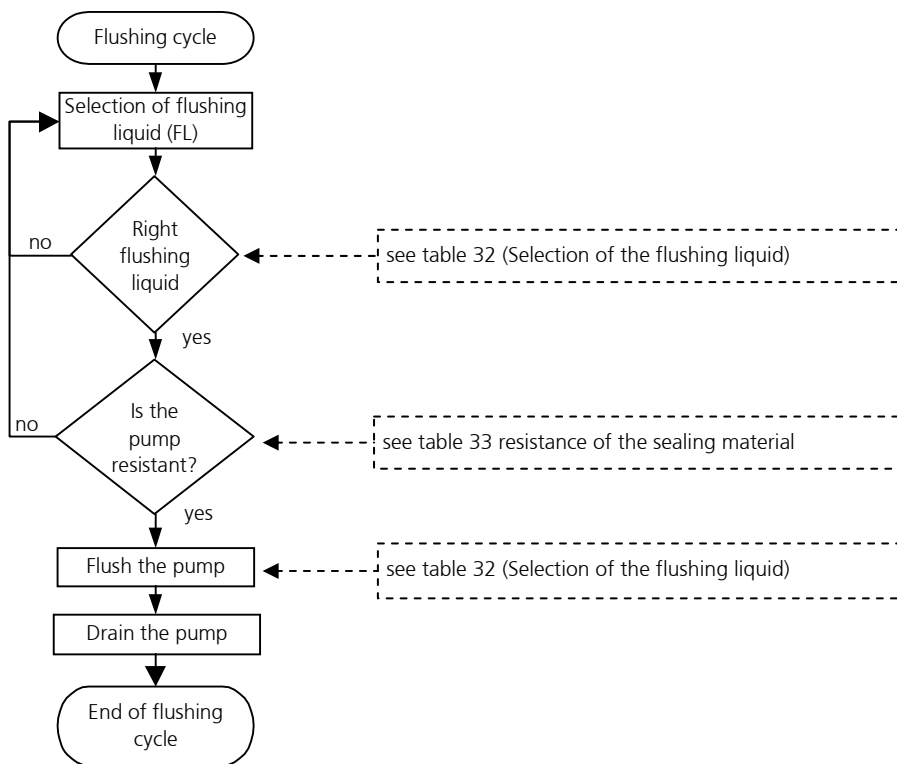

figure 23 Diagram of the flushing procedure

Warning

Liquids that remain in the pump may crystallize, coagulate or lead to corrosion and as a consequence impair the work of the micro annular gear pump.

Warning

Please make sure that the pump components and particularly O-rings and sealing are resistant to the employed flushing liquid. (see table 33).

Warning

The flushing liquid (solvent) and the recommended duration of the flushing procedure depend on the delivered liquid (see table 33). The indicated flushing liquids are simple recommendations and should therefore be checked by the user as to their compatibility and suitability.



Regulations concerning use of substances dangerous to health should be followed!

	Nature of the delivered liquid	Flushing time [min]	Suitable flushing liquid
1	Oils, fats, plastifierrss	15-20	isopropanol, ethanol, acetone, benzine/petroleum ether
2	Solvents (polar + nonpolar)	5-10	isopropanol, ethanol
3	Other organic liquids	10-15	isopropanol , ethanol
4	Refrigerating and cooling agents	15-20	isopropanol, ethanol
5	Neutral water/y solutions	20-25	isopropanol, ethanol
6	Basic solutions	25-30	DI-water (deionized water)
7	Organic acids	30-40	isopropanol, ethanol
8	Weak mineral acids	25-30	DI- water
9	Strong mineral acids	35-45	DI- water
10	Strong oxidizing liquids	35-45	DI- water
11	Paints, varnishes, adhesives	50-60	not specified - for further information please contact HNP Mikrosysteme.

table 32 Selection of the flushing liquid (solvent) and the duration of the flushing procedure depending on the delivered liquid.

Warning

Please make sure that the pump components and particularly O-rings and sealing are resistant to the employed flushing liquid (see table 33).

Flushing liquid	Shaft sealing		O-ring material		
	PTFE (Teflon®), graphite- reinforced	UHMWPE	FKM (Viton®)	EPDM	FFKM
acetone	0	0	3	0	0
benzene	0	3	1	3	0
benzyl alcohol	0	-	0	2	0
butanol	0	-	1	0	0
dimethyl sulfoxide (DMSO)	0	0	3	0	0
ethanol	0	0	0	0	0
isopropanol	0	0	0	0	0
methanol	0	0	2	0	0
methylethylketone (MEK)	0	0	3	1	0
styrene	0	-	1	3	1
toluene	0	1	2	3	0
water	0	0	0	0	0
xylene	0	1	2	3	0
benzine/petroleum ether	0	0	0	3	0
oil / fine mechanics oil	0	0	0	3	0

Legend: 0 ... good suitability 1 ... suitability 2 ... conditional suitability 3 ... labile - ... not specified

table 33 Resistance of the sealing materials depending on the flushing liquid (solvent)

8.4 Shutdown of the micro annular gear pump

In order to shut down a mzf-pump the following steps should be followed:

- Flush the pump with a filtered and particle-free flushing liquid (solvent) as described in the chapter 8.3.
- After the flushing procedure decrease speed of the pump to 0 rpm
- Fill the pump with a suitable conservation liquid (see chapter 8.4.1)
- Remove the pump from the system (see chapter 8.4.2)

By proceeding as shown in the diagram (see figure 25) you may prepare the pump for a longer standstill.

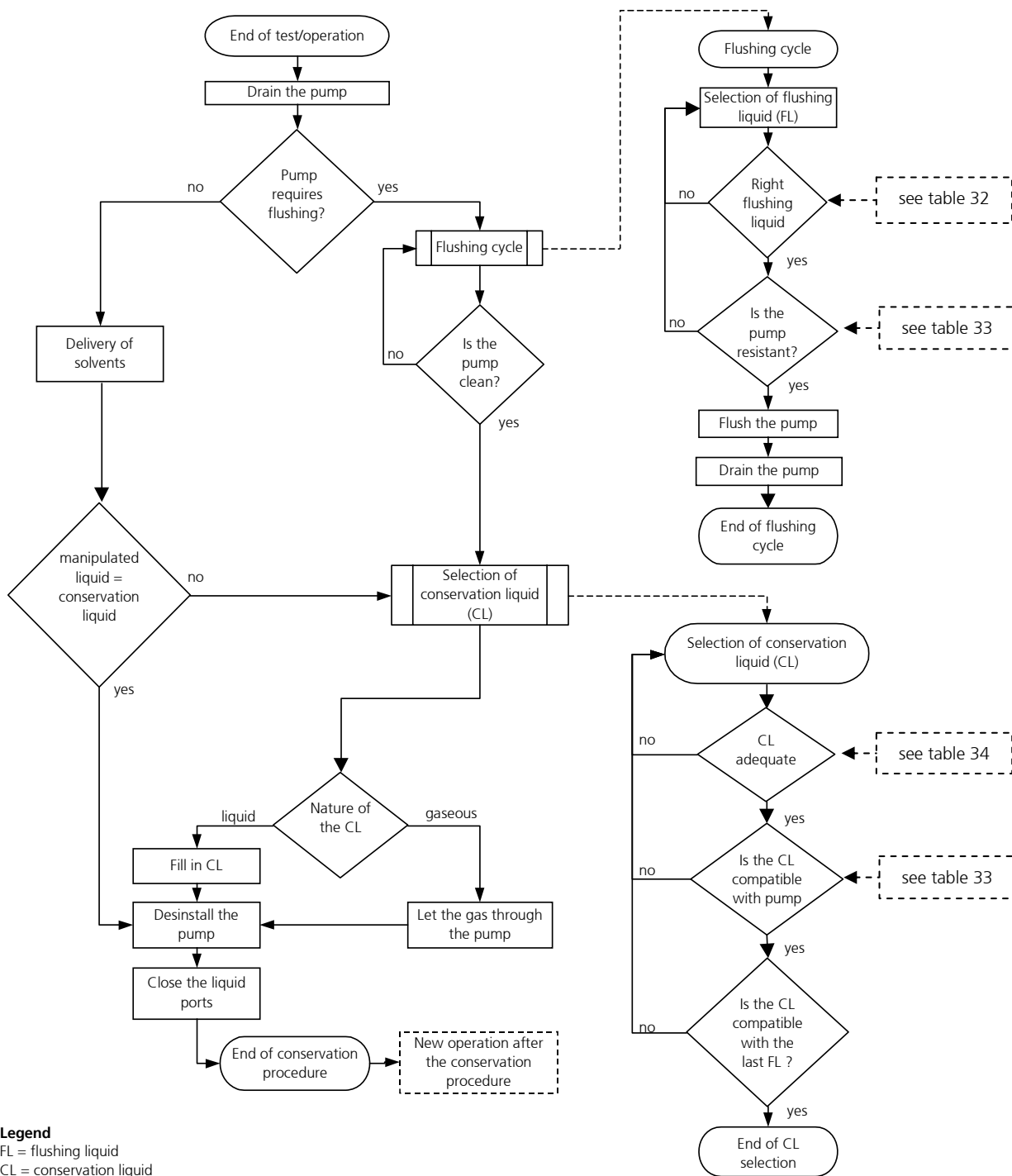

figure 24 Diagram of the shutdown procedure

8.4.1 Conservation

If the micro annular gear pump operates at irregular intervals or for other reasons should be put out of operation for a longer period, it should, after service and flushing procedure (see chapter 8.3), be filled in with a suitable conservation liquid.

The conservation liquid may be selected from the table 34 depending on the duration of the standstill and the resistance of the pump to the manipulated liquid. The indicated conservation liquids are simple recommendations and should therefore be checked by the user as to their compatibility and suitability. The figure 25 presents a diagram of conservation agent selection.

Remark: This diagram is repeated as a part of the figure 24 (shutdown procedure of the micro annular gear pump).

After the cleansing procedure the pump should be filled with a suitable conservation agent. You will find a choice of possible conservation agents in the table 34.

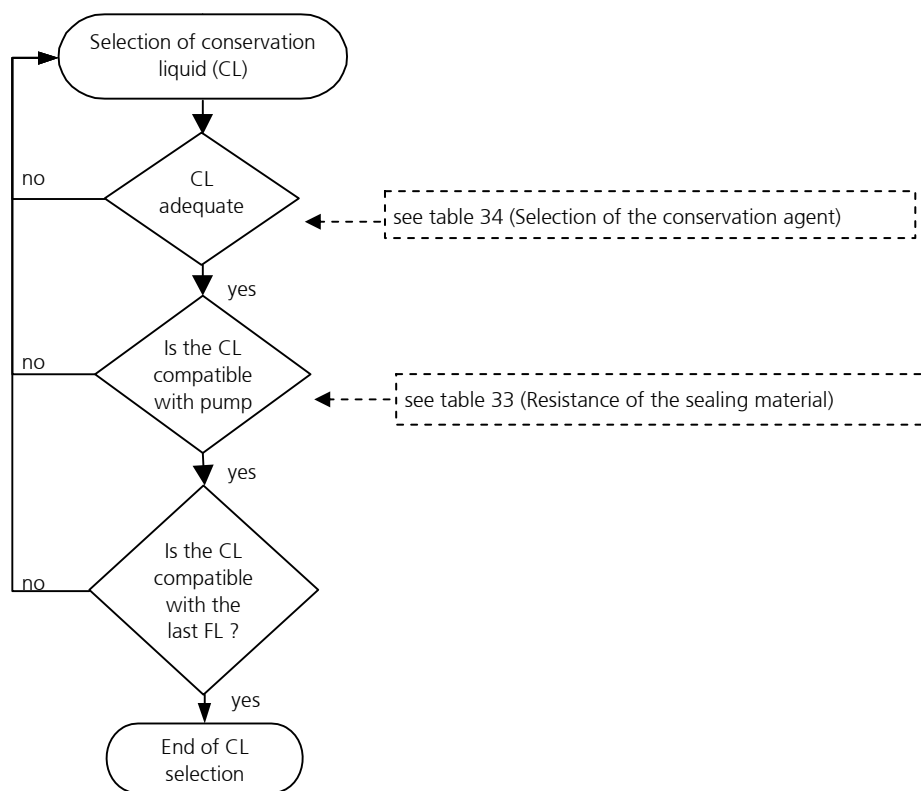

figure 25 Diagram - selection of conservation liquid (CL)

Liquids	Solubility in water	Compatibility with the delivered liquid	Duration of storage	Breakaway torque	Toxicology	Viscosity	Description
isopropanol	+	+	o	o	o	+	solvent for organic compounds, cosmetics, essential oils waxes, and esters, antifreezers, antiseptic agents
acetone	+	+	o	o	o	+	solvent for a number of organic compounds, unlimited solubility in water, dissolves natural and synthetic resins, fats, oils and commonly used plastifiers
ethanol	+	+	o	o	o	+	solvent for organic compounds, fats, oils and resins
DI-water	+	+	-	-	+	+	solvent for many organic and mineral liquids
fine mechanics oil	-	-	+	+	+	+	cleansing and protective action (dissolves fats, tar, rubber or adhesive substances, protects against corrosion).
hydraulic oil	-	-	+	+	+	-	lubricating and preserving properties (<i>Warning</i> : may resinate or deteriorate with time)
nitrogen	-	+	+	+	o	+	is not a solvent, may leave deposits after drying out
air / compressed air		+	+	+	+	+	is not a solvent, may leave deposits after drying out

Legend: + ... good/suitable o ... satisfactory; - ... bad/inadequate

table 34

Selection of the conservation agent

In order to prevent dust particles and foreign bodies from penetrating into the pump or the conservation agent from leaking out, please secure the liquid input and output openings with the delivered protective plugs or screws.

Warning

Water or DI-water should not be used as conservative liquids. They germinate already after a few days and build a biofilm which can later block the pump.

8.4.2 Dismantling of the system

- Put the drive out of operation by turning down speed to 0 rpm and by switching off the voltage supply. Make sure that the procedure described in the chapter 8.3 has been completed.
- Now that the pump has been stopped you may remove it from the system.
- Protect the inlet and outlet openings of the pump with adapted protective plugs or screws.

8.5 Problem shooting

If the pump stops operating abruptly or has difficulties with starting operation, please undertake the following steps:

Try to liberate the micro annular gear pump:

- by turning the potentiometer knob back and forth or by connecting an analog voltage
- via the control software
- by pressing with a syringe a suitable flushing liquid (see table 32 and table 33) through the micro annular gear pump
- by changing the operating direction of the pump.

If these measures turn out to be ineffective, please contact the service staff of HNP Mikrosysteme (see chapter 20) and send the pump back to the manufacturer for inspection.

Warning

You should under no condition try to disassemble the pump by yourself. This may cause damage to the pump components and consequently annul your warranty claims.

8.6 Return of the micro annular gear pump to the manufacturer

For the return of a micro annular gear pump and components that have already been employed, please follow the instructions:

- drain any remaining rests of the delivered liquid from the pump
- flush the pump with an adapted solvent
- remove the filter elements from integrated or loosely delivered filters
- protect all openings against dust with the delivered protective plugs or screws
- return the pump in its original packing

The service personnel which carries out the repair should be informed about the condition of the already used micro annular gear pump. This is done by means of the "Declaration of media in contact with the micro annular gear pump and its components" (see chapter 17). This form may also be downloaded from the web site www.hnp-mikrosysteme.de/download.



The "Declaration of liquids in contact with the micro annular gear pump and its components" must imperatively be filled in. The nature of liquid which entered into contact with the micro annular gear pump and its components must be specified.

In case of non-compliance, the sender will be liable for any resulting injure to persons or any object damage.

9 Software »Composer« and »Elmo Studio« (Option for S-HP-E)

The » Composer « software enables operation and configuration of the drive and offers a possibility of an online graphic analysis of the operating data. The software is delivered on CD. The program may be installed on a PC running under Windows 2000®, Windows XP® and Vista® operating systems.

Install the software » Composer « by starting the program »Setup« on the CD.

After the installation the » Composer « program may be started from the folder from the Windows start menu.

In order to program the drive the micro annular gear pump should be put into operation. The drive and the PC should be connected with the delivered "RS232-COM cable".

All chapters described below are explained very detailed in the documentations of the controller manufacturer.

9.1 Use application of CD

Load the application contained on the CD with the default parameters of the micro annular gear pump.

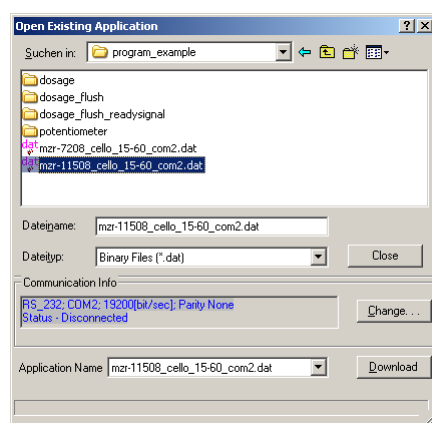

Figure 26 Open Existing Application

The serial port RS-232 can change with button »Charge«.

The communication opens via button "Download". The program in the EEPROM of the controller is deleted after a prior notice.

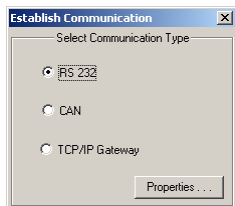

Figure 27 Select Communication Type

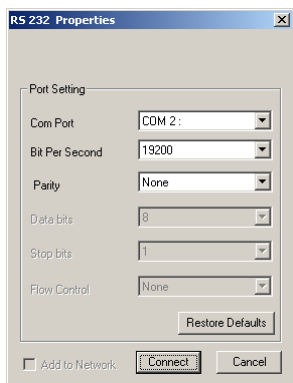

Figure 28 RS-232 interface properties

9.2 Creating a new application

Following windows are to go through to create a new application.

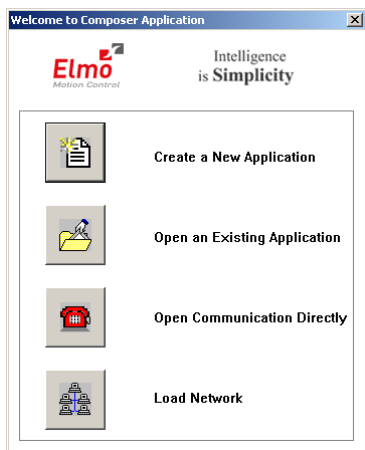

Figure 29 Welcome windows to Composer applications

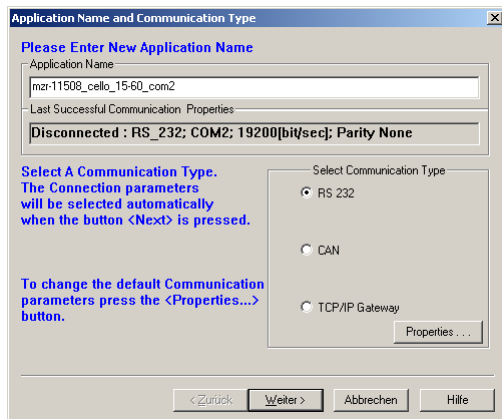

Figure 30 New Application name

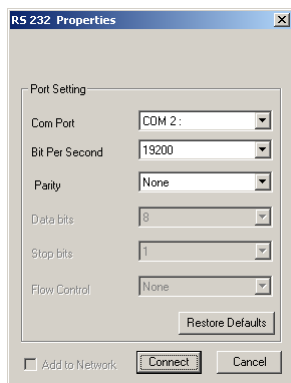

Figure 31 Selection of the relevant interface

Subsequently run the automatic scan of the serial port.

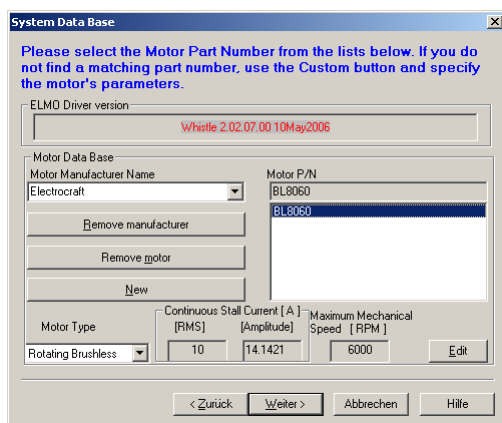

Figure 32 Adjustment of the motor data

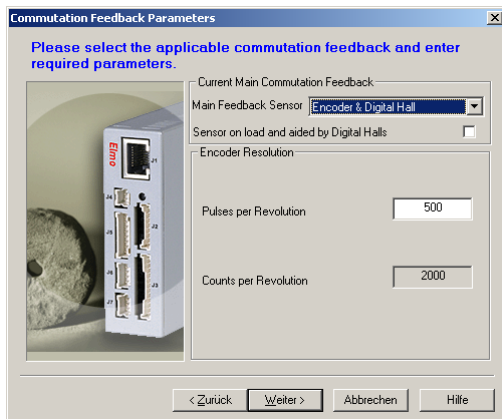

Figure 33 Adjustment of the encoder data

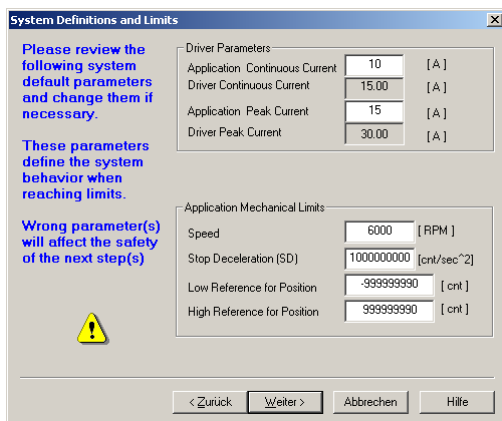

Figure 34 Adjustment of the driver parameter

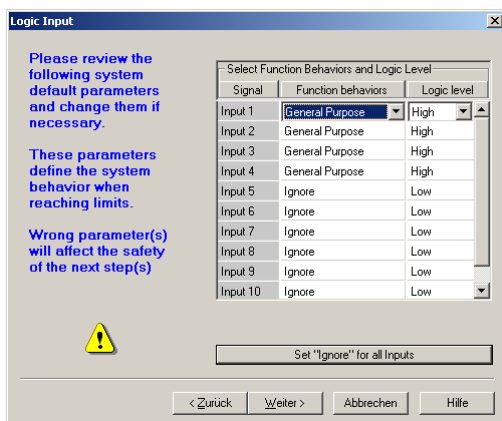

Figure 35 Adjustment of the digital inputs

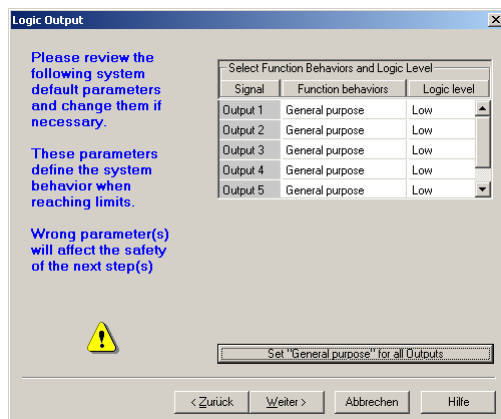

Figure 36 Adjustment of the digital outputs

9.3 Adjustment of controller parameter

The controller parameters of the controller must be set for the operation of micro annular gear pump. If the controller settings are noted with an uneven running of the motor tuning of the controller, a further optimization will be carried out.

The controller settings can be easily implemented on the following window.

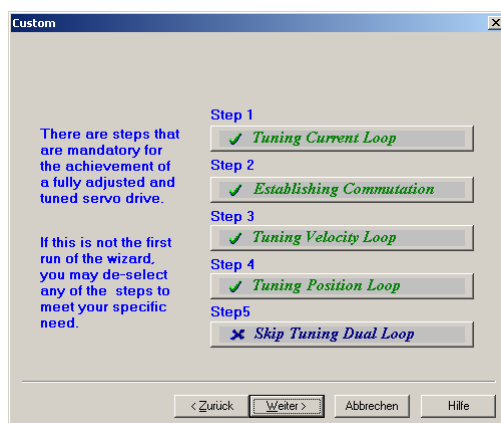

Figure 37 Adjustment of controller parameter

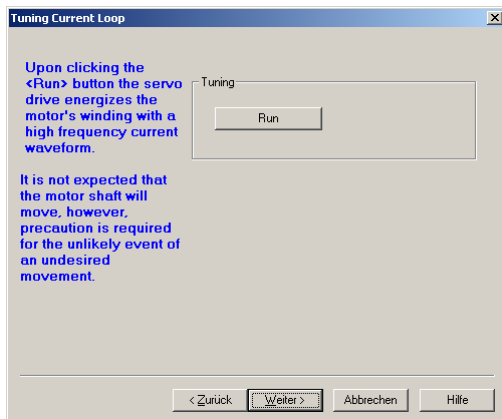

Figure 38 Start Autotuning



Figure 39 Start commutation test

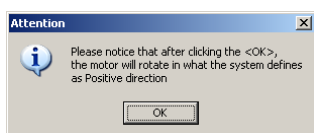

Figure 40 Advice turning the motor shaft

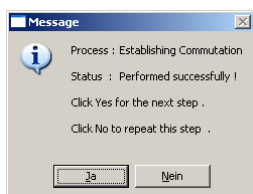

Figure 41 Message with status

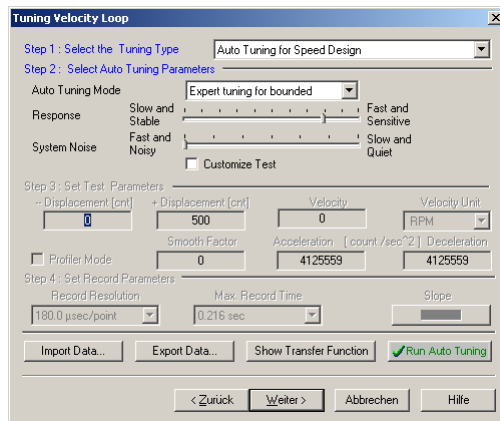

Figure 42 Tuning parameter of velocity loop

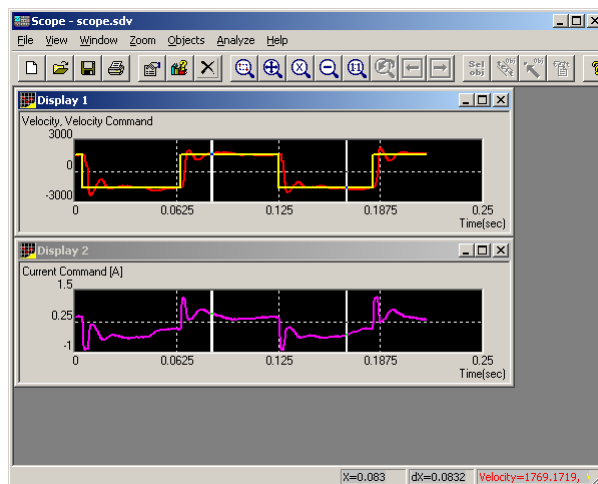

Figure 43 Windows scope motor velocity

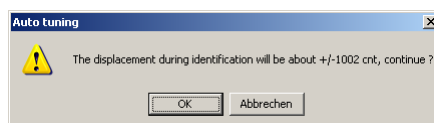

Figure 44 Advice window of motor rotation

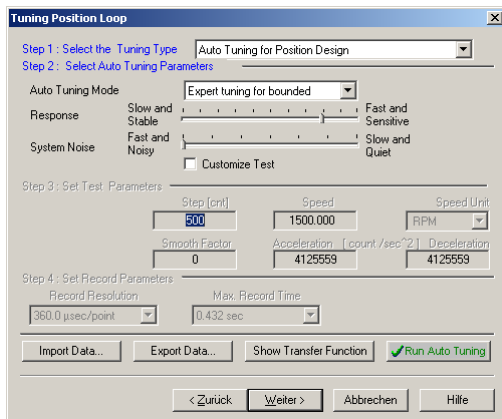

Figure 45 Tuning parameter of position loop

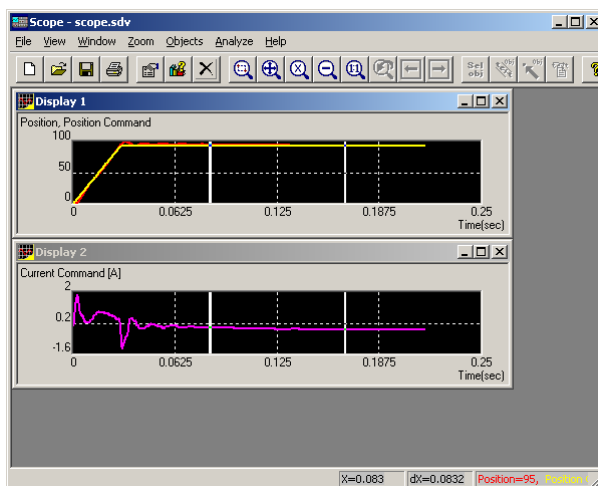

Figure 46 Windows scope motor positioning

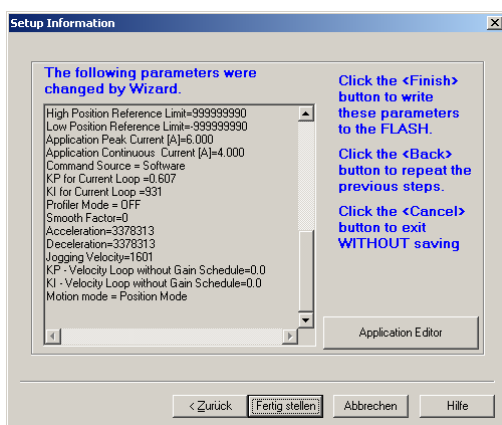

Figure 47 Setup Information

After adjustment of controller parameters, all parameters are saving with *parameter/Save all parameters*.

9.4 Operation of micro annular gear pump with RS-232 interface

In the *velocity mode*, the velocity of the pump motor speed is adjustable.

An example for continuous delivery

Command	Description
1000	Rotation speed of 1000 rpm
3000	Rotation speed of 3000 rpm
0	Standstill of the pump (speed 0 rpm)

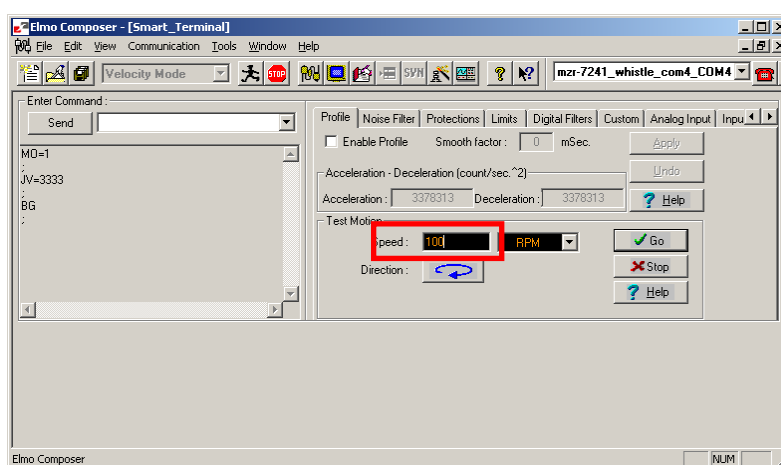
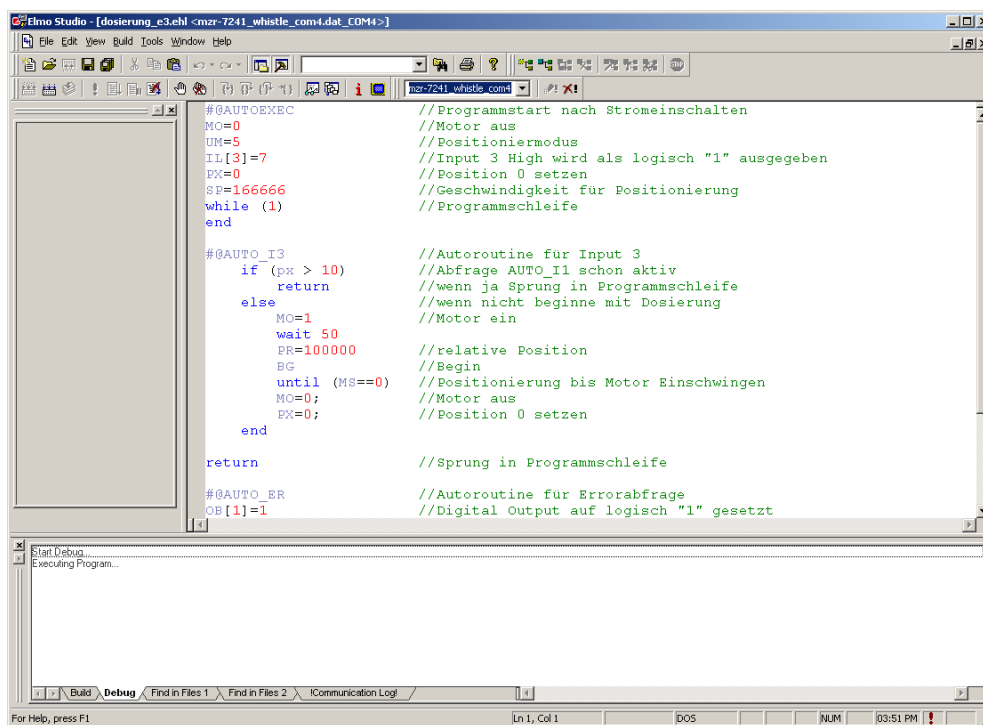

Figure 48

Speed adjustment

9.5 Operation of micro annular gear pump as stand alone application

With the software "Elmo Studio" sequence programs are permanently save in the controller. The programs start automatically when the supply voltage.



```

Elmo Studio - [dosierung_e3.ehl <mzt-7241_whistle_com4.dat_COM4>]
File Edit View Build Tools Window Help
mzt-7241_whistle.com4

#@AUTOEXEC //Programmstart nach Stromeinschalten
MO=0 //Motor aus
UM=5 //Positioniermodus
IL[3]=7 //Input 3 High wird als logisch "1" ausgegeben
PX=0 //Position 0 setzen
SP=166666 //Geschwindigkeit für Positionierung
while (1) //Programmschleife
end

#@AUTO_I3 //Autoroutine für Input 3
if (px > 10) //Abfrage AUTO_I1 schon aktiv
return //wenn ja Sprung in Programmschleife
else //wenn nicht beginne mit Dosierung
MO=1 //Motor ein
wait 50
PR=100000 //relative Position
BG //Begin
until (MS==0) //Positionierung bis Motor Einschwingen
MO=0; //Motor aus
PX=0; //Position 0 setzen
end
return //Sprung in Programmschleife

#@AUTO_ER //Autoroutine für Errorabfrage
OB[1]=1 //Digital Output auf logisch "1" gesetzt
  
```

Start Debug...
Executing Program...

Build Debug Find in Files 1 Find in Files 2 Communication Log

For Help, press F1 Ln 1, Col 1 DOS NUM 03:51 PM

Figure 49

Software Elmo Studio

Programming is described in detail in the documentation of the motion control manufacturer explained. Some example programs for dispensing with the micro annular gear pump are included on the CD

9.6 Problems and their removal with controller S-HP-E

Error	Possible cause of error	Action
LED does not light up	No power supply	Check all power switches
LED lights	Motor does not rotate	Using the software for error check of the controller
Control is not responding	Wrong interface	Überprüfen, ob am PC die richtige Schnittstelle verwendet wird, ggf. umstecken oder EPOS die richtige Schnittstelle mitteilen
	wrong cable assignment	Check the wiring, correct if necessary
Motor hums whistles, or swinging	Controller parameters are not optimal	Controller parameters to check (see "Regulation tuning") in the separate manual control

table 35

Excerpt error control S-HP-E



If a disturbance that has not been mentioned in the above list, or that makes the use of the micro annular gear pump unsafe appears, please stop the operation of the pump without delay and contact the manufacturer.

10 Software »Motion Manager« (Option for S-BL)

The »Motion Manager« software enables operation and configuration of the drive and offers a possibility of an online graphic analysis of the operating data. The software is delivered on two diskettes. The program may be installed on a PC running under Windows 2000®, Windows XP® and Vista® operating systems.

If the »Motion Manager« diskettes are not available, and you have received for example the »mzr- pump control« software, you may still download this program from the following web site: www.faulhaber.de. Here, the latest version is always available in German and English. (*Download - Motion Manager*).

Install the software »Motion Manager« by starting the program »Setup« on the CD.

After the installation the »Motion Manager« program may be loaded from the »Faulhaber Motoren« folder from the Windows start menu.

In order to program the drive the micro annular gear pump should be put into operation. The drive and the PC should be connected with the delivered null-modem cable.

10.1 Direct drive control

In the »Motion Manager« software the input commands may be sent directly to the drive. This enables to execute the movement commands and to modify the drive parameters.

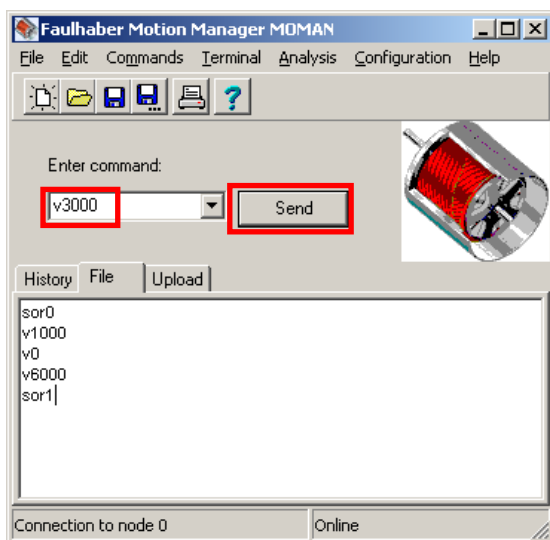

figure 50

Motion Manager software for direct control of the drive

The commands are entered in the field »Enter command:«. The button »Send« will send the command to the drive for execution (see figure 50). The commands may be given alternatively in capital letters or low case. The drive will ignore excess space characters.

An example for continuous delivery

Commands	Description
SOR0	Operating mode RS-232: Set the nominal speed via the RS-232 interface
V1000	Rotation speed of 1000 rpm
V0	Standstill of the pump (speed 0 rpm)
V6000	Speed value 3000 rpm
SOR1	Analog input of the operating mode: setup of the nominal speed with the potentiometer knob or by connecting an external voltage signal to the analog input

An example for discrete dosage

Command	Description
SOR0	Operating mode RS-232: set the position via RS-232 interface
LR10000	Load a relative position of 1000 to the control unit 10,000 = 10 rotations (Remark: 1000 steps = 1 rotation)
M	Execute the task / start positioning
LR20000	Load a relative position of 2000 to the control unit 20,000 = 20 rotations
M	Execute the task / start positioning
SOR1	Analog input operating mode: Set nominal speed with potentiometer or by connecting a voltage signal to the analog input

In case of the mzs-11508X1 micro annular gear pumps 1 revolution of the rotor corresponds to 1000 steps. The gear reduction is to be considered while using a gear reduction module.

For more details concerning the operation of the Motion Manager, please read the online program help.

10.2 Programming of the control

The control of the micro annular gear pump may be adapted by the user to a specific task by means of an easy programming language. The program files are available in the ASCII code and have by default the »mcl« extension which stands for "motion controller language". Various parameters of the drive such as the maximal speed, the acceleration, the number of rotations, the allowable

current load and the parameters of the PI-controller may be programmed with this language. Furthermore, it is possible to program short movement sequences which will be saved in the internal memory of the drive and then autonomously executed.

10.2.1 Transfer of a mcl file to the drive

The existing mcl files may be loaded to the file editor window using the menu command *File - Open...* (in the program window).

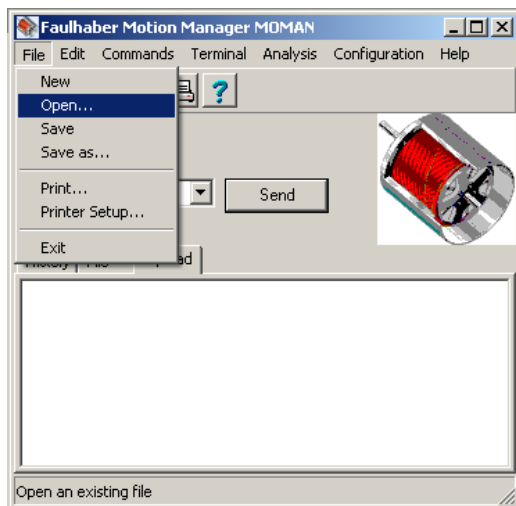

figure 51

Menu file- open

The required mcl file may be selected and loaded via the file selection window (see figure 51). By using the menu command *Terminal - Transfer configuration file* the mcl file will be transferred to the drive (see figure 52).

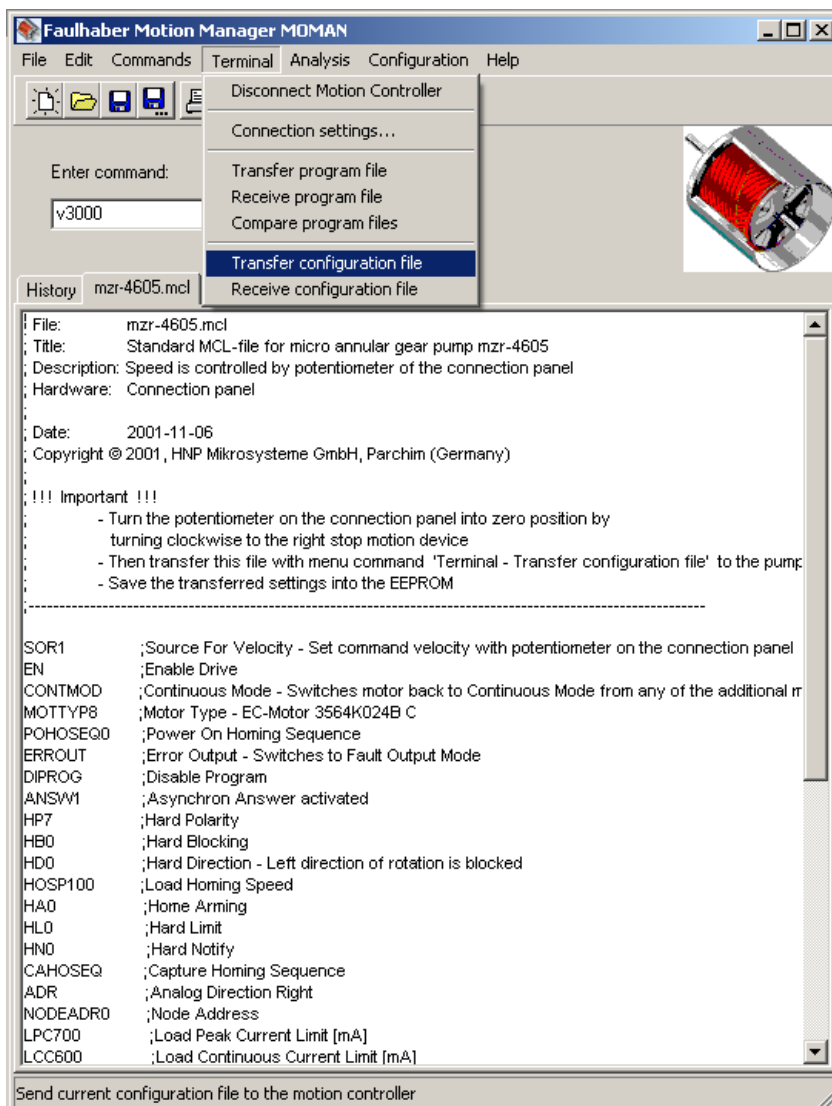

figure 52 Transfer of the mcl files as parameter data

When a window appears with the enquiry if the mcl files should be transferred to the »Motion-Controller«, answer by clicking on the »Yes« button.

In order to save the configuration and the programmed operation files in the EEPROM, confirm the dialogue window with »OK« (see figure 53). By this confirmation the program will be saved in the memory with a resident status and will be available for future operation.

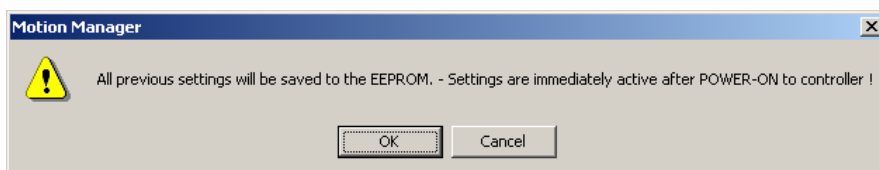

figure 53 Storage confirmation

A diskette or CD with sample mcl programmes is delivered optional along with the Motion Manager. At the delivery the pump has a standard program configuration. Moreover, a sample program that may be started with an external switch is available for discrete dosage tasks.

Pump type	Standard program	Sample program for dosage tasks
mzr-11508	mzr-11508_S.mcl	dosierung_11508_e3_S.mcl

table 36

Overview of mcl sample programs

11 Software » EPOS UserInterface« (Option for controller S-HP-M)

The » EPOS UserInterface « software enables operation and configuration of the drive and offers a possibility of an online graphic analysis of the operating data. The program may be installed on a PC running under Windows 95®, Windows 98®, Windows NT®, Windows 2000® or Windows XP® operating systems.

Install the software » EPOS UserInterface « by starting the program »EPOS_CD-ROM« on the CD.

After the installation the » EPOS UserInterface « program may be loaded from the Windows start menu.

In order to program the drive the micro annular gear pump should be put into operation. The drive and the PC should be connected with the delivered "RS232-COM cable".

All chapters are described in the documentation of the control manufacturer in great detail.

11.1 Startup Wizard for mzs-11508

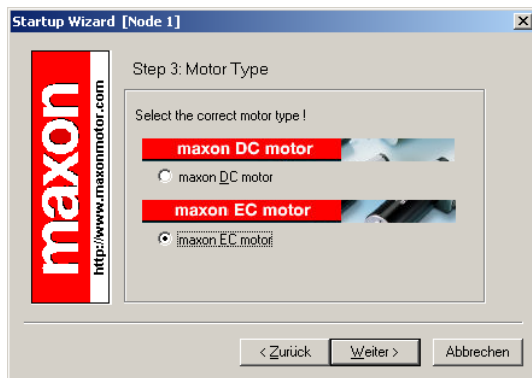

figure 54

Startup wizard dialog for setting RS232 communication

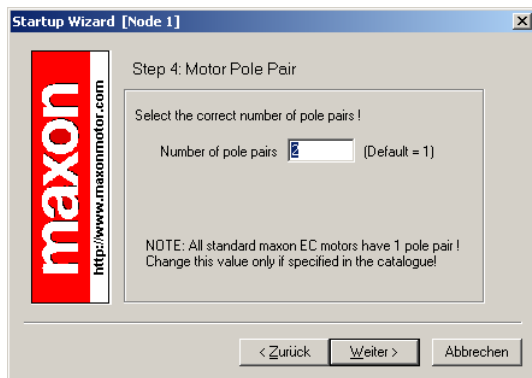

figure 55 Startup wizard dialog for choosing motor type

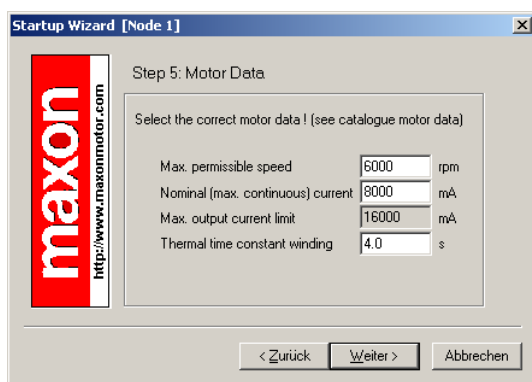

figure 56 Startup wizard dialog for choosing motor data

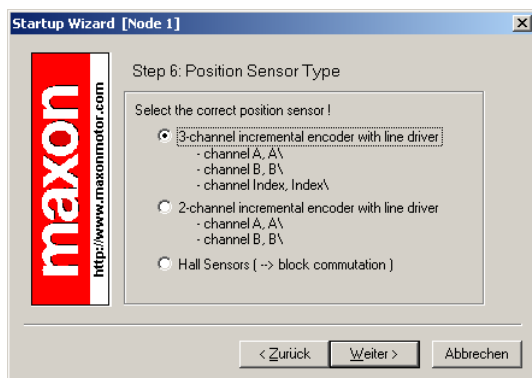

figure 57 Startup wizard dialog for choosing encoder type

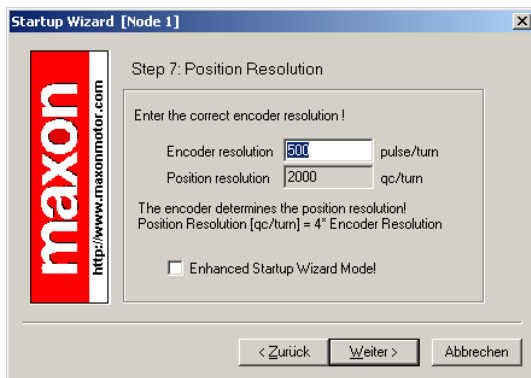

figure 58 Startup wizard dialog for choosing the encoder resolution

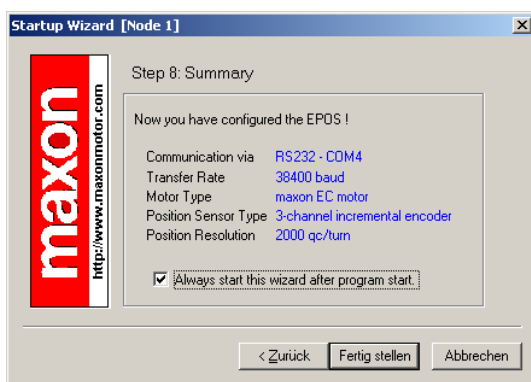

figure 59 Summary of the configuration

11.2 Adjustment the control parameters

The control parameters of the controller must be set for operating the micro annular gear pump. If this control settings restless running of the motor should be established on a further *Regulation Tuning* optimization controls are implemented.

The regulator setting can easily realize the following windows.

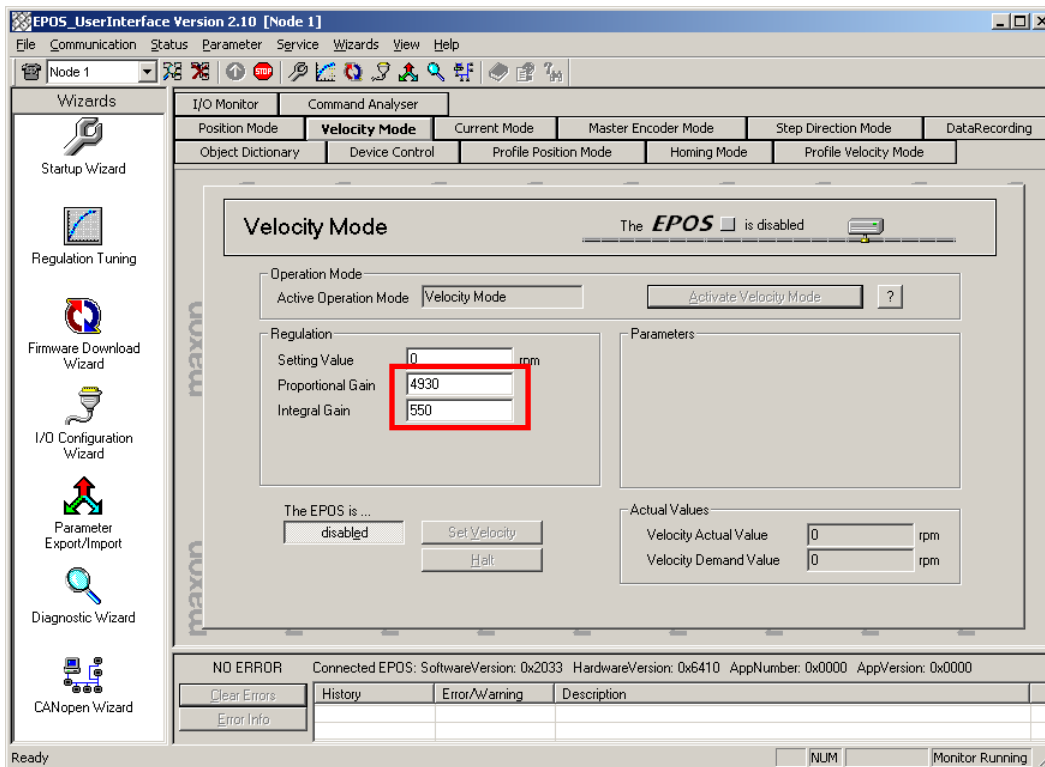

figure 60 Adjustment of regulations for velocity mode

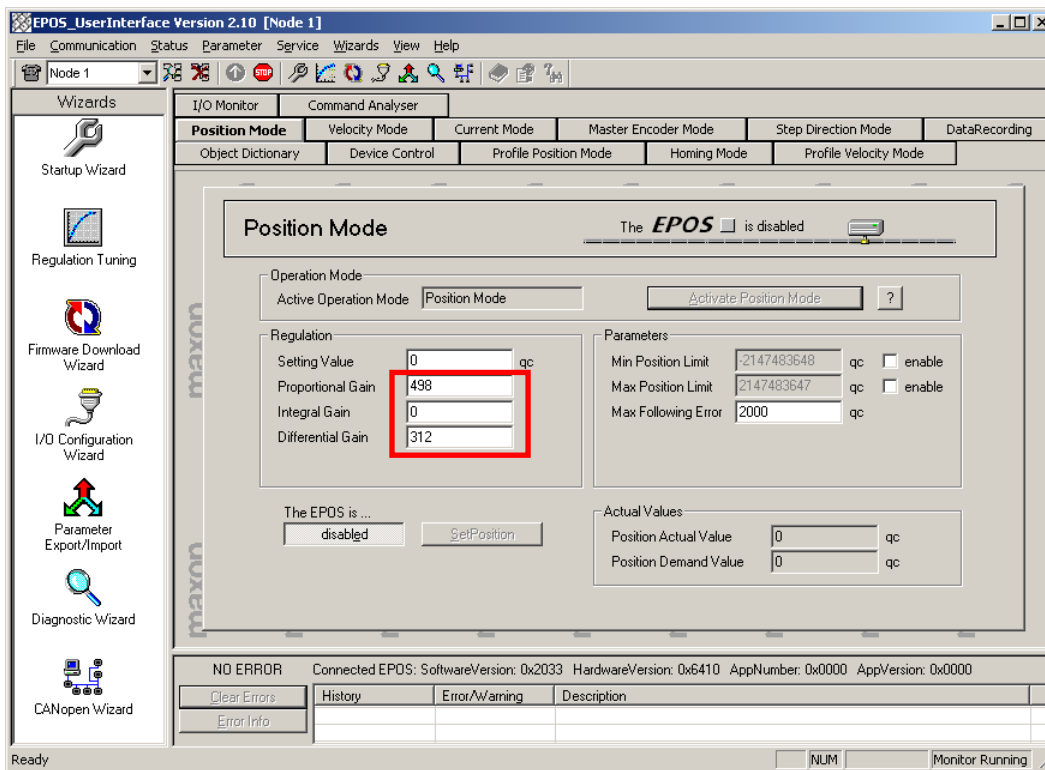

figure 61 Adjustment of regulations for position mode

After setting the parameters should control all the parameters of *Parameter/Save all Parameter* are save.

11.3 Direct drive control

In *Velocity Mode* is the motor speed of the pump set.

An example for continuous delivery

Setting Value	Description
1000	Operate the pump at 1000 rpm (Flow rate: mzs-11508 = 192°ml/min)
3000	Operate the pump at 3000 rpm (Flow rate: mzs-11508 = 576°ml/min)
0	Pump at rest (speed 0 rpm)

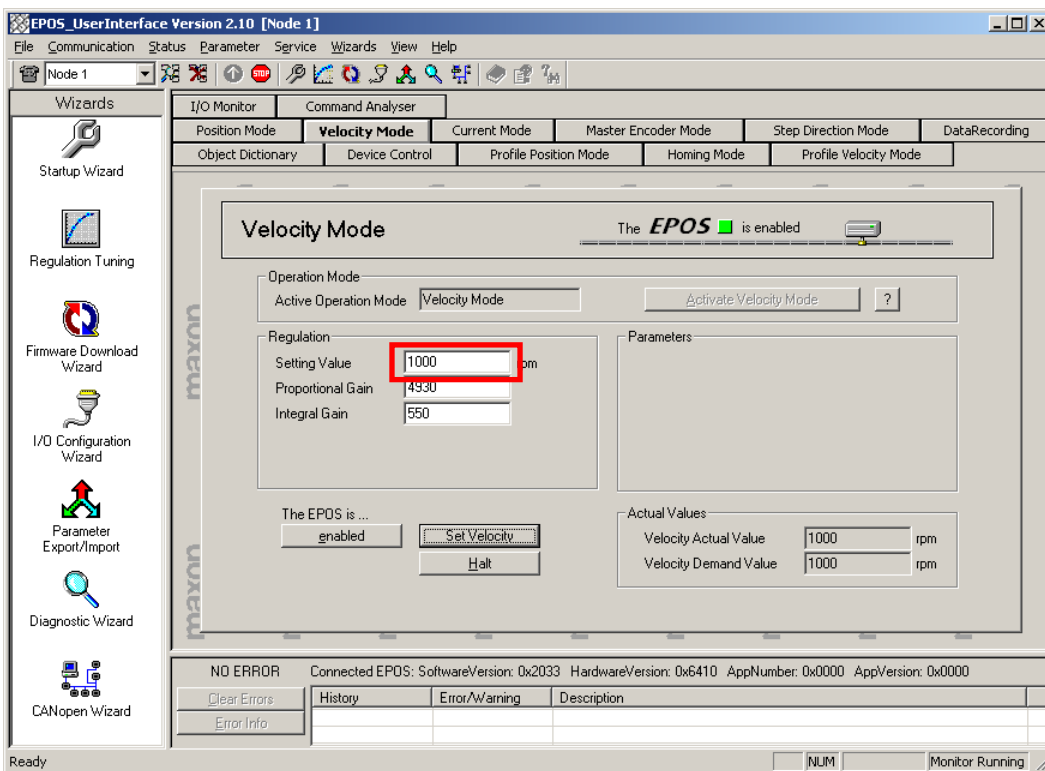

figure 62 Surface for velocity mode

11.4 LED Status

The green LED shows the operating status and the red LED indicates an error of the positioning controller S-HP-M. Detailed information may be found in the Firmware Specification document.

Disturbance	Cause	Solution
LED not shine	power supply does not works	Check the wires on fixed seat, review of the power supply voltage measuring device on basic function
LED lights rot	controller error	Review error of the controller with the help of software
Controller not answer	wrong interface	Check that the right on the PC interface is used or controller notify the right interface
	wrong cable position	Check cable position
Motor whistling, buzzing or oscillates	Control parameters are not optimally set	Check the control parameters (see „regulation tuning“ in the separate manual of the controller)

table 37 Excerpt of errors controller S-HP-M



If a disturbance that has not been mentioned in the above list, or that makes the use of the micro annular gear pump unsafe appears, please stop the operation of the pump without delay and contact the manufacturer.

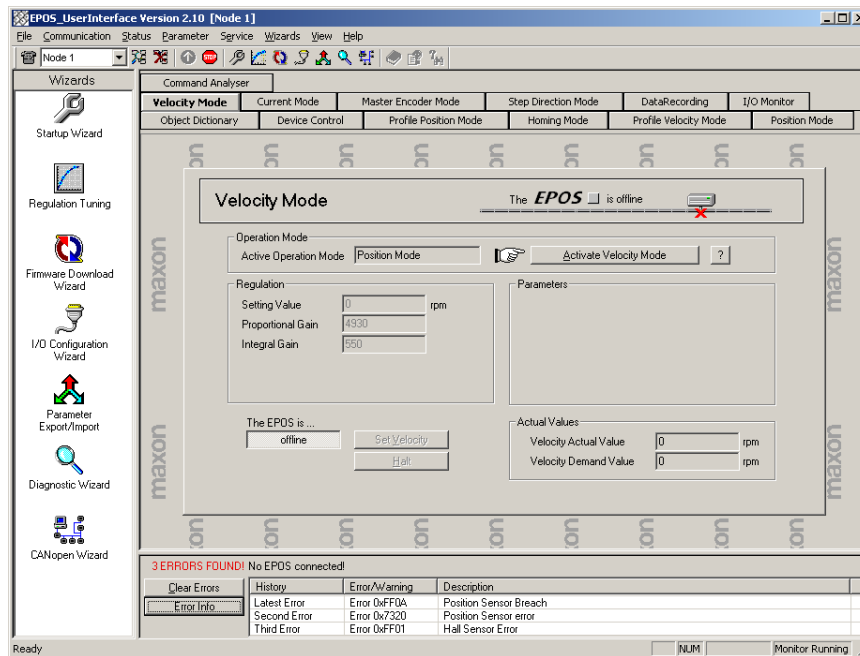

figure 63 Error messages of not connected micro annular gear pump

12 Software »EPOS« (Option for S-HP)

For Windows® user we provide the E-Motion software EPOS 6.51 (see figure 64), a fully functional configurations and operations manager with online graphic performance analysis.

Install the software » EPOS « of CD, included in the delivery volume.

Installation of EPOS

1. Insert EPOS Installations CD
2. Select Windows » START -> run «
3. Enter " D:\Einstall " (D: drive unit stands for the CD-ROM) and activate the installation with OK. Alternatively search the drive unit or directory that contains the installation file " Einstall.exe" .
4. Follow the installation statements on the screen until the installation end is indicated.
5. This CD contains in addition a full illustrated installation statement in the PDF- format / Win200_Install_eng.PDF. At the finished installation of EPOS still a few simple operating system adaptations are necessary.

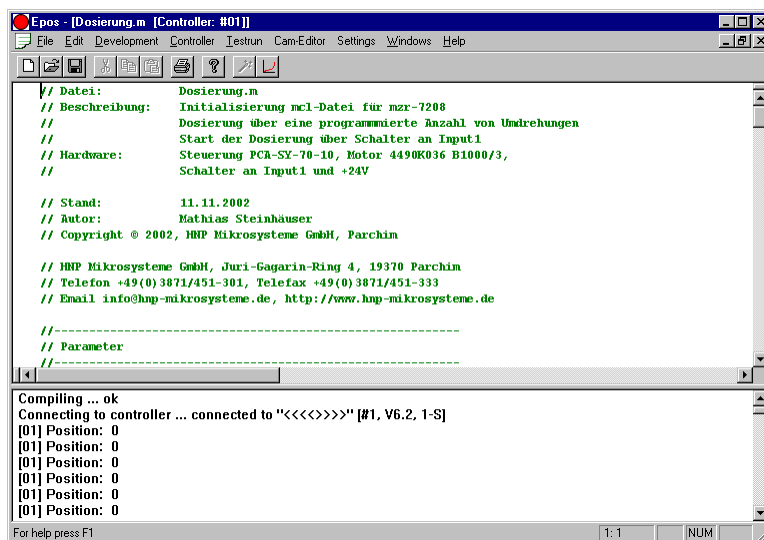

```

Epos - [Dosierung.m [Controller: #01]]
File Edit Development Controller Testrun Cam-Editor Settings Windows Help

// Datei:      Dosierung.m
// Beschreibung:  Initialisierung mcl-Datei für mzt-7208
//               Dosierung über eine programmierte Anzahl von Umdrehungen
//               Start der Dosierung über Schalter an Input1
// Hardware:    Steuerung PCA-SY-70-10, Motor 4490K036 B1000/3,
//               Schalter an Input1 und +24V

// Stand:      11.11.2002
// Autor:      Mathias Steinhäuser
// Copyright © 2002, HNP Mikrosysteme GmbH, Parchim

// HNP Mikrosysteme GmbH, Juri-Gagarin-Ring 4, 19370 Parchim
// Telefon +49(0)3871/451-301, Telefax +49(0)3871/451-333
// Email info@hnp-mikrosysteme.de, http://www.hnp-mikrosysteme.de

//-----
// Parameter
//-----

Compiling ... ok
Connecting to controller ... connected to "<<<<>>>" [#1, V6.2, 1-S]
[01] Position: 0
[01] Position: 0
[01] Position: 0
[01] Position: 0
[01] Position: 0
[01] Position: 0
For help press F1
1: 1 NUM
  
```

figure 64

Software EPOS for motor control

To use the EPOS-Software please read the Online-Help and the manual on CD. For stand-alone use without a PC the delivery volume contains a disk with

m-files, which could be downloaded to the control unit and saved permanently to the EEPROM.

13 Problems and their removal

Error	Possible cause of error	Action
1 No function	No power supply	Check all power switches
2 Pump does not dose	No dosage liquid in the tank	Fill the liquid tank
	Motor error	Check motor Status of the pump with the software Motion Manager
	Dosage needle blocked	Check and clean the dosage needle
	Back-pressure valve does not work	Check the back-pressure valve
	No signal for start dosage	Check the start signal of the central control unit (PLC)
	Pump error	Replace pump and send the pump to the manufacturer
3 Pump does not prime during bringing the dosage system into service	Pump does not suck	Check of the installation
	-"-	Check air pressure on tank
	-"-	Back-pressure valve does not open, Check the back-pressure valve!
	-"-	Air bubbles in fluid system (tubings, valves)
	Tubings leak	Change the tubings
4 Motor works but pump does not pump	No liquid in pump	Prime the pump
	Air bubbles in fluid system (tubings, valves)	Prime the pump and the fluid system
	Valve not open	Flush the valve
	Dosage needle blocked	Clean, flush or change the dosage needle
	Coupling of the connection motor –pump is loose	Replace pump and send the pump to the manufacturer
	Pump shaft is broken	Replace pump and send the pump to the manufacturer
5 Pump does not pump but is filled with liquid	Particle in dosage liquid or pump blocked	Check Status of the pump with the software Motion Manager Try to get free the pump with negative prime speed (-500 rpm) for only 1 s
	-"-	Don't change the parameter of the motor with command »FCONFIG«, »LPC«, »LCC«!
	-"-	Flush the pump with the syringe
	Back-pressure valve not open	Flush the valve
	Dosage needle blockade	Clean or flush the needle
	Air bubbles in fluid system (tubings, valves)	Fill/Prime the pump and the fluid system
6 Dosage volume does not correspond with the datasheet or calculation	Air bubbles in fluid system and pump	Flush the fluid system and check the fluid system for opening connections
	Filter dirty	Change the filter
	Back-pressure valve not open	Flush the back-pressure valve
7 Liquid leaks out of the dosage needle (dosage needle drops)	Back-pressure valve not closed	Flush the back-pressure valve
	Pressure at process liquid tank	Disconnect the pressure connection of the process liquid tank
8 Liquid leaks out of the sealing liquid needle	Pressure at sealing liquid tank	Disconnect the pressure connection of the sealing liquid tank
9 Dosage volume reduces over the time	Filter dirty	Change the filter
	Dirt or deposition in the pump	Flush the pump or send the pump to the manufacturer for cleaning
10 Leak at the pump body	Seal out of order	Send the pump to inspection to the

Error	Possible cause of error	Action
		manufacturer
11 Leak of the fluid connections	Flangeless ferrules leak	Change the flangeless ferrules
12 Status of the pump cannot be checked or calibrated	No contact/connection to the pump	Check the power supply of the pump
	-"-	Check the connection of the zero modem cable between PC and dosage system or try to use a new cable
	Motor control out of order	Switch the power supply for a short time OFF and then ON to start the motor control again
13 Over temperature	Pump surface dirty	Clean the pump surface
	Pump works heavy	Flush the pump
14 Over current	Pump works heavy	Dosage needle damage, replace the needle
	-"-	Dosage needle blockade, clean or flush the needle
	Back-pressure valve not open	Flush the back-pressure valve
	Particle in dosage liquid	Flush the pump
15 Under voltage	Supply voltage < 12 VDC	Check the power supply voltage
16 Over voltage	Supply voltage > 28 VDC	Check the power supply voltage

table 38

Trouble shooting guide



If a disturbance that has not been mentioned in the above list, or that makes the use of the micro annular gear pump unsafe appears, please stop the operation of the pump without delay and contact the manufacturer.

14 Accessories for microfluidic systems

The accessory range for the liquid delivery systems of HNP Mikrosysteme comprises complementary equipment such as hoses, tubes, fluid fittings, filters and non-return valves that are best adapted to your micro annular gear pump. We will eagerly share our long date experience as far as component selection is concerned.

15 Non-liability clause

HNP Mikrosysteme GmbH shall not be liable any damage resulting form the non-respect of instructions comprised in this operating manual.

It belongs to the user to check the integrity, the correct choice and the suitability of the product for the intended use.

It remains at the responsibility of the user to conform to all laws, rules and regulations in force. This applies above all to the treatment of aggressive, poisonous, corrosive and other dangerous liquids.

16 Service and maintenance

For service and maintenance, you have the possibility to send your micro annular gear pump to HNP Mikrosysteme (the address is found on the cover of this manual). In measures of the service package, seals and other parts subject to wear are exchanged.

17 EC Directive

A Directive or EC Directive is a legal instrument of the European Community addressing at the member states and forcing them to implement specific regulations or targets. Leastwise, micro annular gear pumps are covered, by the scope of application of the following Directives: The following directives are of importance for the user of the described micro annular gear pumps:

Low-Voltage Directive (2006/95/EC)

The Low-Voltage Directive is not relevant for micro annular gear pumps described in this manual, because the supply voltage is limited to a maximum of 30 VDC.

Machinery Directive (2006/42/EC)

A micro annular gear pump is a machine and is consequently covered by this Directive. However, it may be a part of a machine or installation.

EMC Directive (2004/108/EC)

The Directive on Electromagnetic Compatibility (EMC) applies to all electronic and electrical devices, installations and systems. Consequently, the Motion Controller of the micro annular gear pump is covered by the EMC Directive.

RoHS Directive (2011/65/EC)

To our knowledge our products delivered to you do not contain substances or applications in concentrations that are forbidden by this directive. No substances contain our products delivered to you after our current knowledge in concentrations or application, the placing on the market in products according to the valid requirements forbade to the Directive.

WEEE Directive (2002/96/EC)



Disposal of micro annular gear pumps has to be environmentally sound. All materials and liquids have to be recycled in accordance with the relevant regulations. Electrical parts can not be disposed of as household waste. They have to be delivered to designated collection points.

REACH regulation (EC) No. 1907/2006

HNP Mikrosysteme is not a manufacturer or importer of chemical substances subjected to registration, but in terms of regulation, a downstream user. As downstream user, we conduct the necessary communication with our suppliers to ensure future deliveries of all components necessary to us. We will notify you of all relevant, changes in our products, their availability and the quality of parts/products delivered by us within our business and coordinate the appropriate action in individual cases with you. Previous inspection did not show any limitation in the supply of material from our upstream suppliers.

17.1 Electromagnetic Compatibility (EMC)

Electromagnetic compatibility is defined as the ability of a electric or electronic device to function satisfactorily as intended in its electromagnetic environment without introducing intolerable electromagnetic disturbances in that environment.

17.1.1 EMC Directive and Standards for controller S-BL

Comformity was proven by proof of compliance with the following harmonized standards by the company Dr. Fritz Faulhaber:

- EN 61000-6-4 (10/01): Generic standards – Emission standard for industrial environments
- EN 61000-6-2 (10/01): Generic standards – Immunity for industrial environments

These standards prescribe certain standardised tests for the emitted-interference and interference-immunity tests. The following tests are required due to the connections on the controller:

Generic Standard on Emitted Interference:	Description
EN 55011 (05/98)+A1(08/99)+A2(09/02):	Radio disturbance characteristics
Generic Standard on Interference Immunity	
EN 61000-4-2 (05/95)+A1(4/98)+A2(02/01):	Electrostatic discharge immunity test
EN 61000-4-3 (04/02)+A1(10/02):	Radiated, radio-frequency, electromagnetic field immunity test
EN 61000-4-4 (09/04):	Electrical fast transient/burst immunity test
EN 61000-4-5 (03/95)+A1(02/01)	Surge immunity test
EN 61000-4-6 (07/96)+A1(02/01):	Immunity to conducted disturbances, induced by radio-frequency fields
EN 61000-4-8 (09/93)+A1(02/01):	Power frequency magnetic field immunity test

Table 2

Standards Summary

All tests were conducted successfully.

17.1.2 Information on use as intended

For micro annular gear pumps, note the following:
Requirement for the intended operation is the operation according to the technical data and the manual.

Restrictions

If the micro annular gear pumps are used at home, in business or in commerce or in small businesses, appropriate measures must be taken to ensure that emitted interferences are below the permitted limit values!

18 Declarations of conformity

The delivered micro annular gear pump falls within scope of the following EC directives:

- Machinery Directive (2006/42/EC)
- EMC Directive (2004/108/EC)

You may request the declarations of conformity for the micro annular gear pumps from us separately.

EC-manufacturer's certificate (following Machinery Directive 2006/42/EC)

We hereby declare that the following micro annular gear pumps of the high performance series:

mzr-11508, mzr-11508X1

are intended for installation into another machinery/plant and that start of operation is forbidden until it is identified that the machinery/plant into which these micro annular gear pumps shall be installed corresponds to the regulations of the EC guidelines regarding safety and health requirements.

We confirm the conformity of the product described above to the following standards in terms of applied directives

– Machinery Directive (2006/42/EC)

Applied standards are particularly

DIN EN 809	DIN EN 60204-1	DIN EN 294
DIN EN ISO 12100 part 1		DIN EN 953
DIN EN ISO 12100 part 2		UVV

This statement does not warrant any characteristics in terms of product liability. Please note the safety instructions in the manual.

Mr. Lutz Nowotka, HNP Mikrosysteme GmbH, Bleicherufer 25, D-19053 Schwerin is authorised to compile the technical file according to Annex VII A.

Date: 30. Dezember 2009

Signature manufacturer:

Dr. Thomas Weisener
CEO

EC-manufacturer's certificate (following EMC Directive 2004/108/EC)

We hereby declare that the following micro annular gear pumps of the high performance series:

mzr-11508X1

are intended for installation into another machinery/plant and that start of operation is forbidden till it is identified that the machinery/plant into which these micro annular gear pumps shall be installed corresponds to the regulations of the EC guidelines regarding safety and health requirements.

We confirm the conformity of the product described above to the following standards in terms of applied directives

- EMC Directive (2004/108/EC)

Applied standards are particularly

- | | |
|-----------------------|---|
| EN 61000-6-4 (10/01): | Generic standards – Emission standard for industrial environments |
| EN 61000-6-2 (10/01): | Generic standards – Immunity for industrial environments |

This statement does not warrant any characteristics in terms of product liability. Please note the safety instructions in the manual.

Date: 30. Dezember 2009

Signature manufacturer:

Dr. Thomas Weisener
CEO

19 Service, maintenance and warranty.

The maintenance of the micro annular gear pump should be carried out depending on the delivered liquid

- *for lubricating liquids* after 12,000 h working hours, but not later than 24 months after the initial operation
- *for non-lubricating liquids, crystallizing liquids or liquids containing particles*, after 5000 h working hours but not later than 12 months after the initial operation. If during the first inspection no substantial wearout of the pump is observed, the following inspection under the same working conditions should be performed after 8000 h working hours, yet not later than 15 months following to the last inspection.

If during the first inspection the pump shows a particularly strong wearout, the maintenance intervals should be readapted to the operating parameters.

In order to prevent a strong wearout of the pump, the pump should be shut down properly after every application as described in the chapter 8.4. A supplementary flushing procedure with a neutral flushing liquid (see chapter 8.3) also slows down the wearout process of the pump.



It is not allowed to open the micro annular gear pumps. The warranty extincts with the expiry of the legal warranty period or with the opening of the pump. Furthermore HNP Mikrosysteme cannot give any warranty of exchange for parts whose damage result from incorrect use.



For service and maintenance please return your micro annular gear pump to HNP Mikrosysteme (You will find the address on the cover of the present operating manual).



The declaration of liquids having had contact with the micro annular gear pump and components must imperatively be completed. The nature of the liquids must be specified. In case of non-compliance the sender will be liable for any resulting injure to persons or any object damage.



Sealings, rotors and shaft are parts that undergo wear and will be replaced by HNP Mikrosysteme GmbH during maintenance depending on their degree of wear.

20 Contact persons

Development and application assistance , service and accessories

Mr. Sven Reimann
Phone +49| (0) 385|52190-349

Service and maintenance

Mr. Steffen Edler
Phone +49| (0) 385|52190-307

Drive and control technology

Mr. Lutz Nowotka
Phone +49| (0) 385|52190-346

21 Legal information

Marks

Kalrez® Spectrum™ is a registered trademark of DuPont.

PEEK™ is a registered trademark of Victrex plc.

Teflon® is a registered trademark of DuPont.

Viton® is a registered trademark of DuPont Dow Elastomers.

HASTELLOY® is a registered trademark of Haynes International, Inc.

Aflas® is a registered trademark of ASAHI Glass Ltd.

Microsoft®, Windows® are registered trademarks of Microsoft Corporation in the USA and in the other countries.

m zr®, MoDoS®, µ-Clamp® are registered German trademarks of HNP Mikrosysteme GmbH.

Other product names or descriptions not mentioned above are possibly registered trademarks of related companies.

Patents

Micro annular gear pumps (and housings) are protected by assigned patents: DE 198 43 161 C2, EP 1115979 B1, US 6,520,757 B1, EP 852674 B1, US 6,179,596 B1, EP 1354135, US 7,698,818 B2. Patents pending: EP 1807546, DE 10 2009 020 942.5-24, DE 10 2011 001 041.6. In the US, Europe and Japan additional patents are pending.

22 Safety information for the return of already employed micro annular gear pumps and components

22.1 General information

The operator carries the responsibility for health and safety of his/her employees. The responsibility extends also to employees not belonging to the company that have a direct contact with the micro annular gear pump and its components during repair or maintenance works. The nature of media (liquids) coming into contact with the micro annular gear pump and its components must be specified in the corresponding declaration form.

22.2 Declaration of liquids in contact with the micro annular gear pump

The staff performing the repair or maintenance works must be informed about the condition of the micro annular gear pump before starting any work on the device. The »Declaration of media in contact with the micro annular gear pump« should be filled in for this purpose.

The declaration should be sent directly to the supplier or to the company designated by the supplier. A second copy of the declaration must be attached to the shipment documents.

22.3 Shipment

The following instructions should be observed for the shipment of the micro annular gear pump.

- drain any remaining liquid from the pump
- flush the pump with an adapted flushing liquid
- remove the filter elements from the integrated or loosely delivered filters
- all the openings should be air-tight plugged
- return the pump in the original packing

23 Declaration of media in contact with the micro annular gear pump and its components

Type of the device

Pump type/serial number/article no.: _____

Operating hours/running time: _____

Number of delivery note or delivery date: _____

Reason of return: _____

Contact with media (liquids)

The micro annular gear pump was in contact with:

and has been rinsed with:

Product info sheet / Material Safety Data Sheet: yes* no

* Please attach file

or is available on the following web site: www. _____

If a pump which had contact with dangerous substances could not be properly cleansed prior to shipment, we reserve the right to entrust a specialized company with cleansing of the device. The return of the pump in original packing is advisable. It is necessary in order to protect the employees and delivery staff.

Nature of media contact:

explosive

oxidizing

sensitive to moisture

toxic (toxic byproducts)

radioactive

pH-value: approx. _____ to _____

carcinogenic

microbiological

other: _____

irritant

corrosive

R-statements: _____ S-statements: _____

Declaration

Hereby I/we affirm that the stated information is complete and correct. Micro annular gear pump and accessories are shipped in conformity with the applicable regulations.

company: _____ Mrs Mr title: _____

division: _____ name: _____

street, no.: _____ phone: _____

ZIP/city: _____ e-mail: _____

country: _____

city, date: _____ authorized signature /

company stamp:

24 Supplement

- Drawings
- Manual of the motion controller S-HV
- Manual of the motion controller S-HP-E (optional)
- Manual of the motion controller S-HP-M (optional)

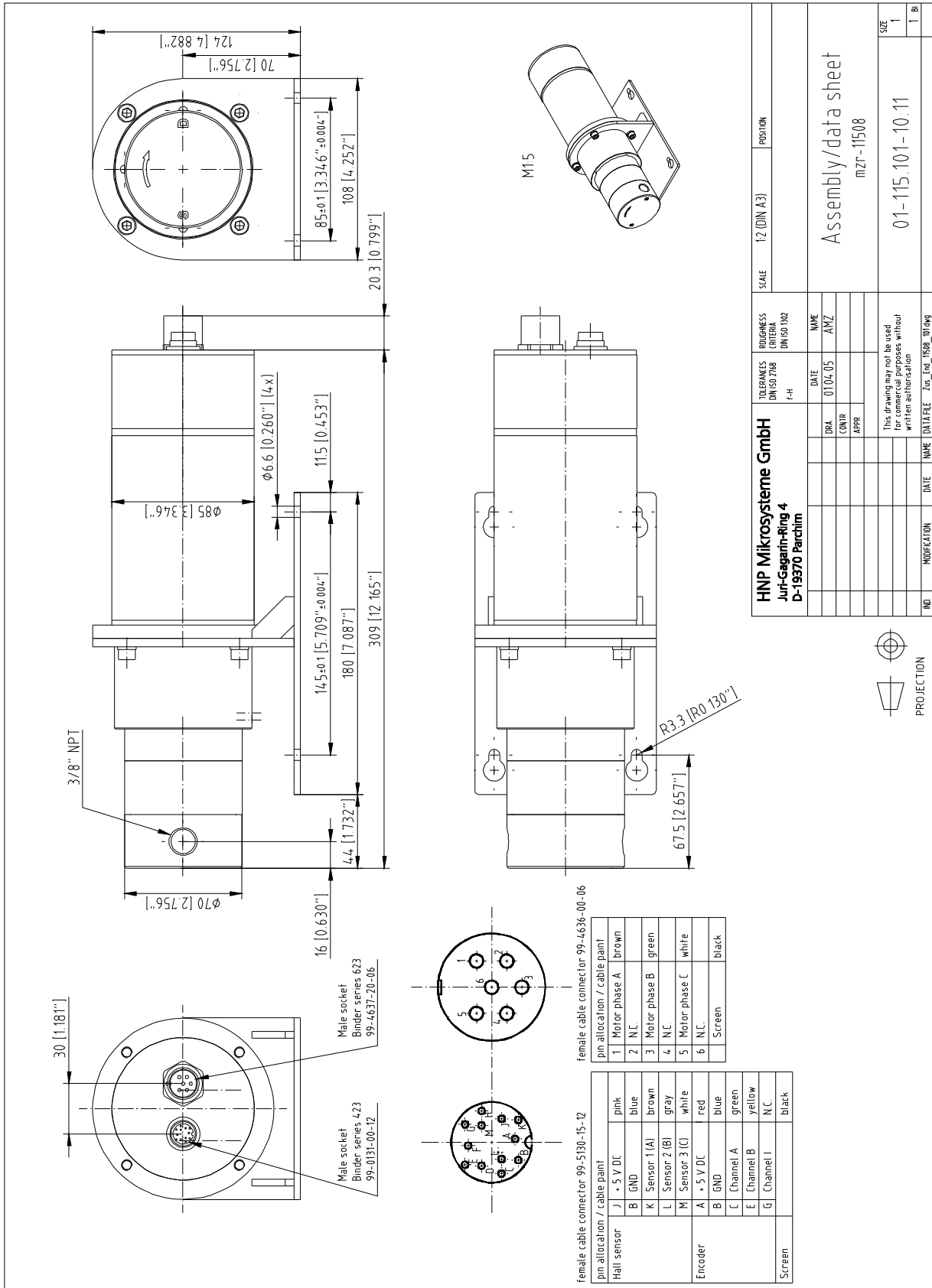

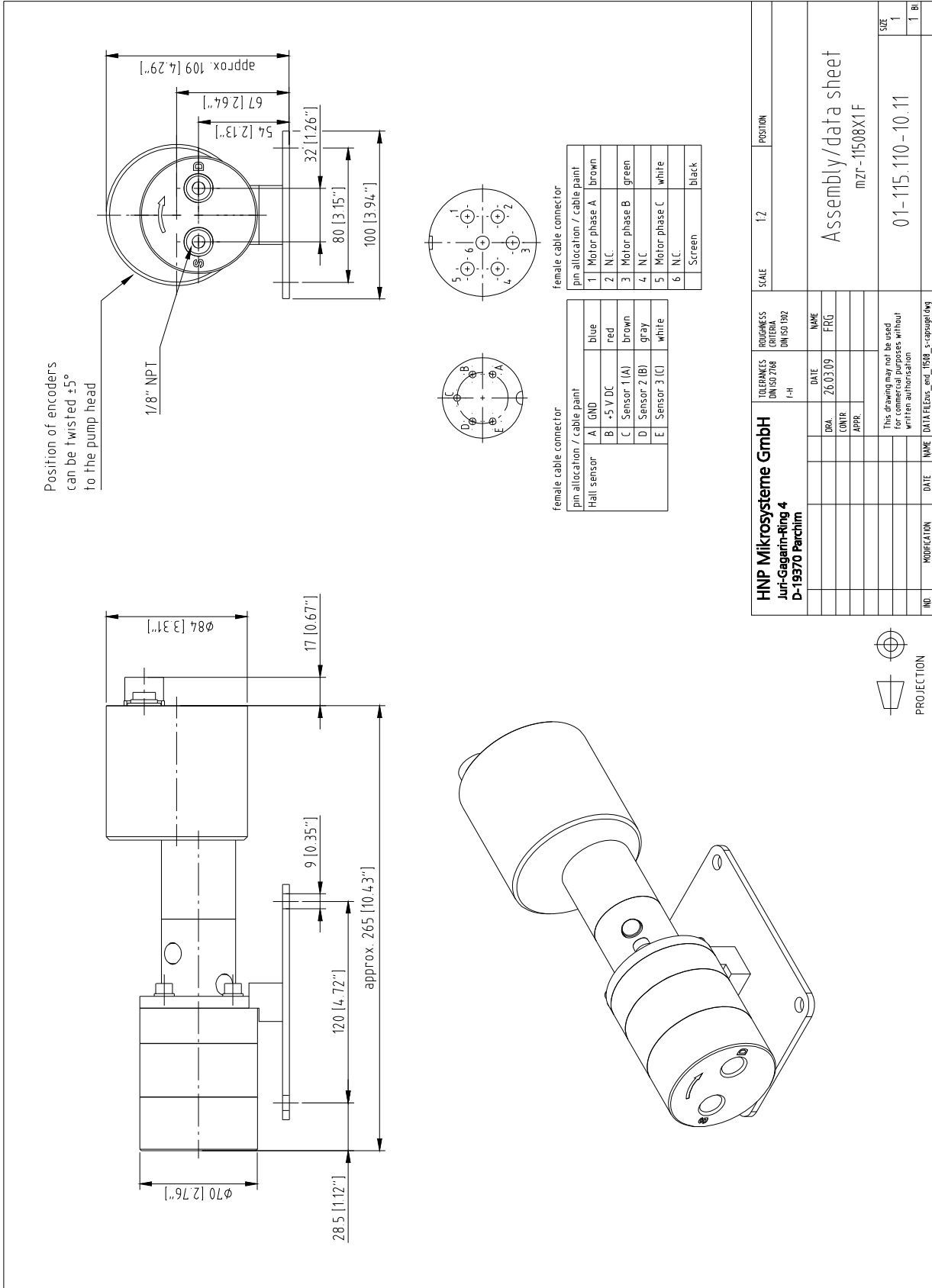

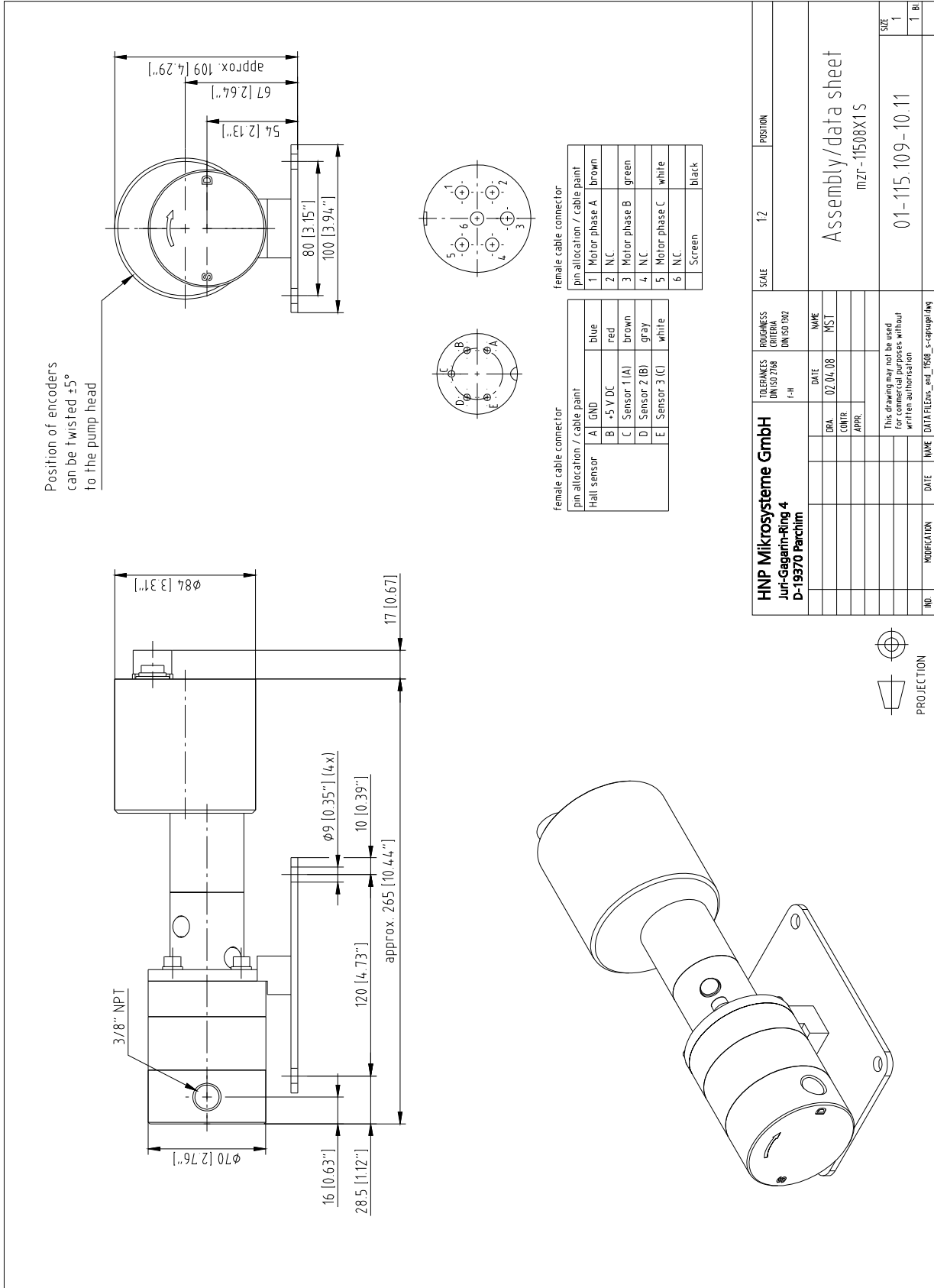

SCA-B4-70-10(70V / 10A)

The servo-amplifier SCA-B4-70-10 is a powerful PWM-module for brushless DC motors with an output range up to 700 Watt.

Three operation modes are integrated

- Torque-control
- Speed-control by digital-encoder feedback
- Speed-control by hallsensors

The required operation mode is to be selected from the front side of the module by setting jumpers. This SCA-B4-70-10 servo amplifier is protected against over current, overheat and short-circuit of the output stage against each other or to the power supply. By the usage of advanced technology and power-MOS-FETs a high efficiency up to 95 %. Due to the wide range of power supply voltage between 11 to 70 V DC the SCA-B4-70-10 can be used very flexible with different kinds of power supplies within many applications. The robust aluminum case has been constructed for different methods of mounting it, therefore a fast integration is possible. screw terminals and a durable controller-design allow a fast and straightforward commissioning.

contents

1.	Safety notes	2
2.	specification	3
3.	preparing	3
4.	commission	5
5.	description of function of inputs and outputs	6
6.	troubleshooting	9
7.	dimensions	9
8.	versions of text	10

1. Safety notes

1.1. skilled personnel

installation and commissioning have to be done only by skilled personnel.

1.2. laws

The user has to ensure the correct installation of the servo amplifier and additional equipment according to valid laws and rules.

1.3. remove load

for first commissioning the motor should run with free shaft which means without load.

1.4. additional safety components

electronic components are not free of failure or damage. Therefore plants have to be installed with additional device and installation protecting components. A safe and stable state has to be ensured in the case of damage of some devices, wrong handling, cable disruption and other cases of any kind of malfunction.

1.5. repairs

repairs have to be done only by authorized distributors or at the manufacturer. Unauthorized opening and improper repairs of the device may cause danger to the user and the plant.

1.6. danger

care about having no power supply voltage all around the plant during installation of the device. Never touch any voltage-carrying components

1.7. maximum input voltage

the input power supply voltage must not exceed 70 V DC. Voltages exceeding 70 V or reversed connection will destroy the unit.

1.8. ESD

do not touch any of the contacts of the device

1.9. EMC

the SCA-B4-70-10 corresponds to the EC directives, standards and regulations 89/336/EEG article 10 and appendix 1 (EMV) amended by 92/31/EEG and 93/68/EEG and meet the requirements with standard EN 61800-3 (1996) if the following directions are observed:

- usage of a zinc plated mounting plate, well connected to earth
- mounting of the drive by usage of toothed washers
- usage of shielded cables to and from the unit
- large area contact of the shielding with zinc plated mounting plate.
- motor housing properly connected to earth

2. specification

2.1. electrical data	power supply voltage	11- 70 V DC
	Current (impulse)	20 A
	Current (nominal)	10 A
	frequency of power output stage	49 kHz
	efficiency	95 %
	bandwidth of current controller	2,5 kHz
2.2. inputs	set value	-10...+10 V
	encoder input signals	channel A, B; TTL max. 100 kHz
	enable	enable 8-30 V (high-active)
2.3. outputs	current monitor „Monitor I“	0,5 V / A
	speed monitor „monitor n“	10 V / nmax
	supervision output Ready	Open Collector max. 30 V DC
	auxiliary voltage source -15 V	20mA
	auxiliary voltage source +15 V	20 mA
	auxiliary voltage source +5 V 100 mA	voltage supply for hallsensors and encoder
2.4. display	2-colour LED	green: ready red: error
2.5. weight	with terminal connector	650 g
2.6. dimensions	(LxWxH)	180 x 100 x 40 mm
2.7. temperature-range	operation	-10...+45°C
	storage	-40...+80°C
2.8. humidity range	non condensing	20% -80% rel. hum.

3. preparing

Required selection of:

- operating mode
- input for set value
- timing
- phasing
- speed range

3.1. operating mode

operating mode	Jumper setting	active potentiometers	minimal connection of control inputs
Torque Control	4	Gain; nmax: I _{max} Offset	6;9-13;17;18
Hall	7;8;9		
Encoder	5;6;7	I _{max} ; Offset	6-13;17;18

3.2. connecting diagrams

Minimalbeschaltungsvariante zur Erstinbetriebnahme

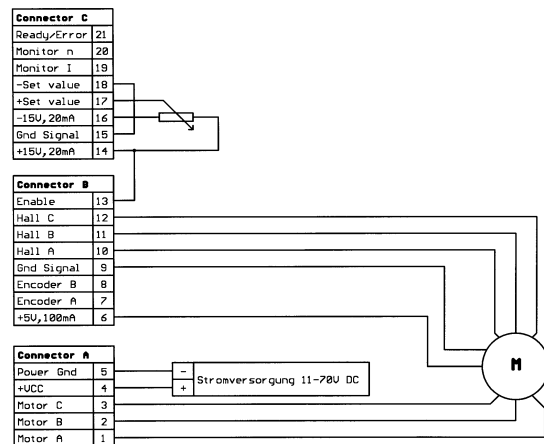

Betriebsart Torque Regelung
Hall Regelung

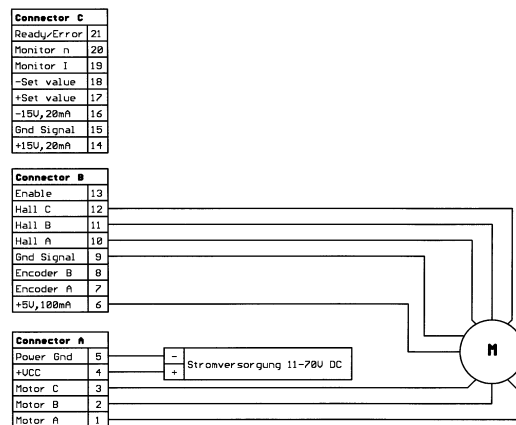

Betriebsart Encoderregelung

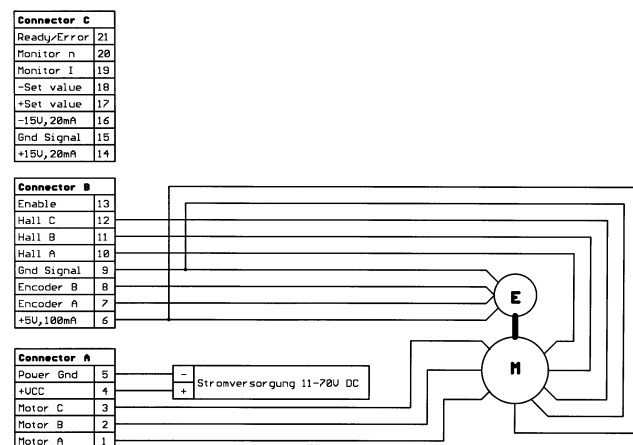

3.3. input for set value

at use of external potentiometer (min. 10 kOhm) for set value the wiper has to be connected to pin17, the others to pins 14 and 16. Pin 15 and 18 have to be connected and J 3 is to be removed. at use of the internal set value via offset potentiometer pin 15 and 18 are left without connection and J3 is to be set.

3.4. Timing

jumper J2 sets the timing of the hall sensor logic to reach an adaptation to several motor types. The setting belongs to the direction of the phases. J2 changes the rotation sense of the electrical field.

3.5. Phasing

jumper J1 is for setting the phase shift of the signals of the hall sensors. The correct value is to provide by the manufacturer of the motor (see datasheet of motor).

3.6. speed range

the speed range is to be set by jumper J10 and J 11. One of four speed ranges is to be set. The best result of speed control can be reached by setting the lowest acceptable range because of the resolution.

4. commission

4.1. selection of power supply.

Any power supply can be used as long the minimal requirements listed below are fulfilled. We recommend to remove the motor from the mechanical construction to avoid damage and danger by uncontrolled movements of

Requirements to the power supply:

output voltage: min. 11 V DC max. 70 V DC

residual voltage: < 5 %

output current: 10 A nominal, 20 A peak

4.2. funktion of potentiometers

potentiometer	function	turning ccw	turning cw
Gain coarse	gain adjustment	decreasing	increasing
Gain fine	gain adjustment	decreasing	increasing
N max	maximum speed at set value of 10 V	decreasing speed	increasing speed
I max	current limitation	decreasing min.0,3A	increasing max 10 A
Offset	adjustment n=0 at set value = 0	Motor turns cw	motor turns ccw

4.3. presetting of potentiometers

original delivered servo amplifiers are adjusted to uncritical values and for easy adjustment by the user.

4.4. adjustment

Hallcontrol Digital-Encoderregelung	1.	adjust max. set value (e.g. 10 V) and turn potentiometer n max cw til the required speed is reached.
	2.	adjust potentiometer I max to required value of current limitation. Important: Refer to motor manufacturer's data sheet.

	3.	turn potentiometer Gain slowly cw until the required gain is reached. Important: If the motor turns rough, is vibrating or makes noise turn potentiometer ccw again, until the instability of the system is obsolete. The potentiometers Gain coarse and Gain fine work in an additive way.
	4.	adjust set value =0V and adjust potentiometer Offset until the motor stops to speed 0.
Torquecontrol	1.	. adjust potentiometer Imax to required value of current limitation. Important: Refer to motor manufacturer`s data sheet.

4.5. commissioning

select the required operating mode by setting the according jumpers on the left side of the unit. Refer to the printing on the front plate.

Required selection of:

- operating mode
- input for set value
- timing
- phasing
- speed range

connect motor, control inputs e.g. set value, enable and if necessary an additional encoder to the drive.

connect power supply.

enabling and adjustment referring to manual.

5. description of function of inputs and outputs

In () the pin number

5.1. inputs

5.1.1. Set value (17,18)

the input for set value is internally connected to an differential amplifier.

input range of set value: -10 V...+10 V

input impedance: 20 kOhm

definition of polarity: positive set value (+Set value) > (- Set value)

negative set value(+Set value) < (- Set value)

Input circuit set value:

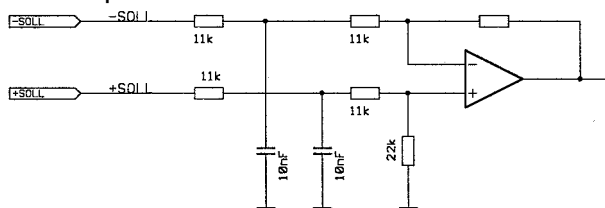

5.1.2. enable (13)

high potential at the input enable will activate speed/torque control and voltage will be applied to the motor winding. Leaving this input without connection or pulling it to the GND-potential will result in disabling the unit.

Input circuit enable:

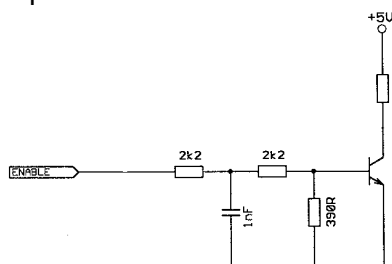

5.1.3.encoder A (7)**5.1.4.encoder B (8)**

the inputs encoder A, B are to be connected to the corresponding outputs of the encoder in operating mode speed control with encoder feedback.

Input circuit encoder:

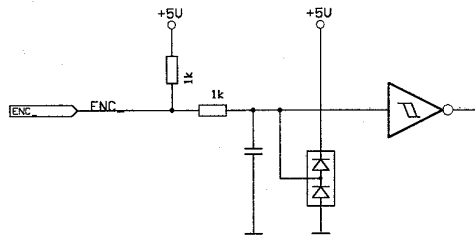
**5.1.5.Hall A (10)****5.1.6.Hall B (11)****5.1.7.Hall C (12)**

Inputs for the Hall effective sensors of the motor. The correct connection regarding phase sequence and phase relation is essential

Input circuit hall effective sensors:

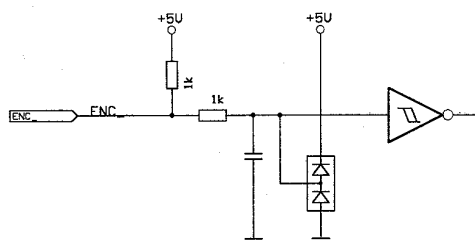
**5.1.8.power gnd (5)****5.1.9.+Vcc (4)**

power supply connection.

caution: DO not connect: +Vcc or Power Gnd to the outputs Motor A, B, or C

5.2. outputs**5.2.1.current monitor Monitor I (19)**

a current monitor for supervisory purposes is integrated to the servo amplifier. The output provides an analog signal (voltage) which is proportional to the motor current.

the monitor output is short circuit proof.

Output range: -10 V...+10 V

Output impedance: 10 kOhm

Output proportionality: 0,5V/A

Output circuit current monitor:

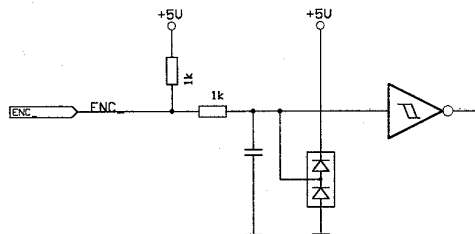

5.2.2. speed monitor Monitor n (20)

a speed monitor for supervisory purposes is integrated to the servo amplifier. The output provides an analog signal (voltage) which is proportional to the motor speed.

It can be used for qualitative weighting of the dynamic of the drive system.

Output range: -10 V...+10 V

Output impedance: 10 kOhm

Output proportionality: 10V at maximum speed

Output circuit speed monitor:

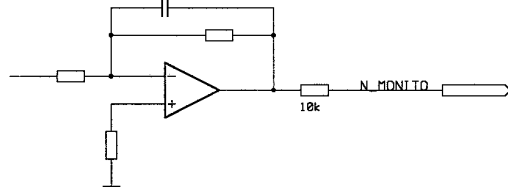

5.2.3. supervision signal Ready / Error (21)

The ready-signal is to show the status of the drive and can be used to provide a feedback signal to other devices and controls. The open-collector output is normally turned off which means the output is pulled to a positive level by an external connected resistor, if there is no fault within the drive system. In the case of a fault like under voltage, overvoltage, overheat or overcurrent the internal transistor is on, the output is pulled to GND.

Input range max. 30 V DC

load current < 20 mA

any fault is stored and can be reset by enable off and on.

Output circuit ready/error signal:

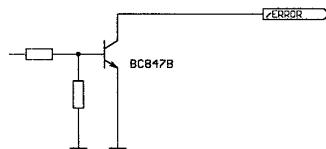

5.2.4. Motor C (3)

5.2.5. Motor B (2)

5.2.6. Motor A (1)

motor connection.

5.2.7.+ 5 V, 100 mA (6)

auxiliary voltage source for power supply of hallsensors and/or incremental encoder

5.2.8.+ 15 V 20 mA (14)

5.2.9.- 15 V 20 mA (16)

auxiliary voltage source for use as reference voltages by setting the set value by the means of an external potentiometer

6. troubleshooting

symptom	operating mode	causes	repair
motor does not turn	all	power supply voltage < 11 V	check power supply
		enable not active	check level at pin 14
		set value = 0V	check set value
		current limitation adjusted too low	check potentiometer adjustment I max
		speed range too low	check potentiometer adjustment n max
		wrong operation mode	check jumper setting
		bad connections	check connectors
no speed control	speed control encoder feedback	encoder signals	check signals and sequence
	speed control hall feedback	gain adjusted too low	check potentiometer adjustment gain coarse and gain fine

7. dimensions

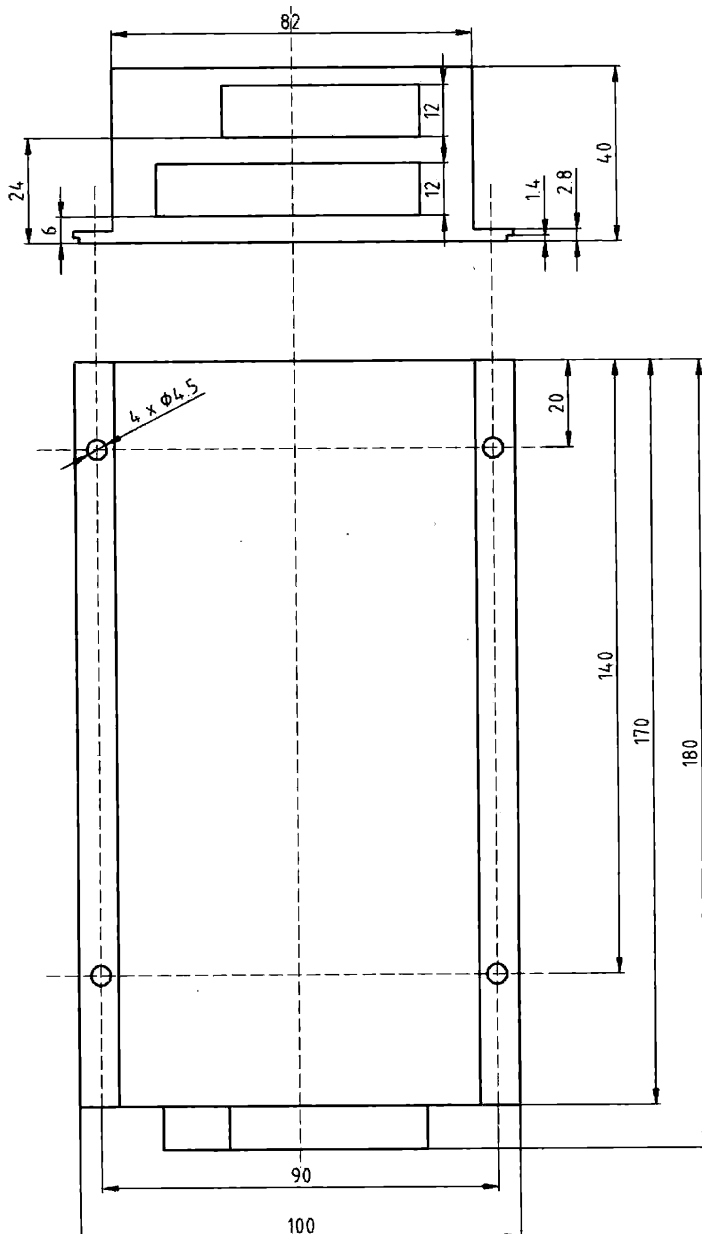

8. versions of text

V1.2 (07/99) expanded version

V1.5 (06.00) additional description of input and output signals encoder, set value, error, enable, monitor. supplementary information of EMC. changed description of function of J2.

V1.6 (01/01) changed description of the error output.