

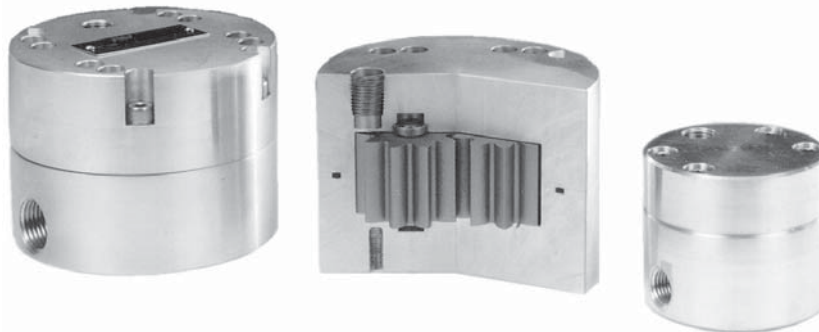

**MODEL B1750
POSITIVE DISPLACEMENT
FLOW METER**

**INSTALLATION & INSTRUCTION
MANUAL**



**8635 Washington Avenue
Racine, Wisconsin 53406
Sales Toll-Free: 800.235.1638
Phone: 262.639.6770 Fax: 262.417.1155
www.blancett.com**



TABLE OF CONTENTS

General Description	4
Installation	4
Flow Meter Guidelines for Paint Operations	8
Typical Automated Cleaning Cycle.....	10
Calibrations	12
Maintaince Guide	15
Troubleshooting Guide.....	21
Statement of Warranty	23

GENERAL DESCRIPTION

The Blancett B1750 positive displacement gear flow meters are similar in design to the gear pump. The principle of operation is reversed; instead of the gears driving the medium, the medium drives the gears. A non-intrusive magnetic pick-up or hall-effect sensor detects the movement of the gear and as each gear tooth passes the sensor a square wave pulse is produced and a discrete volume of liquid is measured. The resulting pulse train is proportional to the actual flow rate and provides a highly accurate representation of the fluid flow. All meters are designed with highly wear resistant moving parts to provide exceptionally long service life.

Filtration:

Depends upon model.

Fluid Compatibility:

The materials of construction include stainless steel or high strength aluminum housings, stainless steel gears and either tungsten carbide or stainless steel bearings (depending upon the model). The fluids should be compatible with these materials.

INSTALLATION INSTRUCTIONS

The preferred flow direction is etched or marked by an arrow on the meter as this is the flow direction in which the meter was calibrated. However, the flow meters have bi-directional flow capabilities. Damage will not occur from reverse flow, but the meter will count reverse flow as forward flow. To prevent this possibility, an in-line check valve may be a consideration.

The preferred orientation is to mount the meter vertically; although horizontal mounting is acceptable if conditions deter vertical orientation. There is no need for straight run piping upstream or downstream of the flow meter.

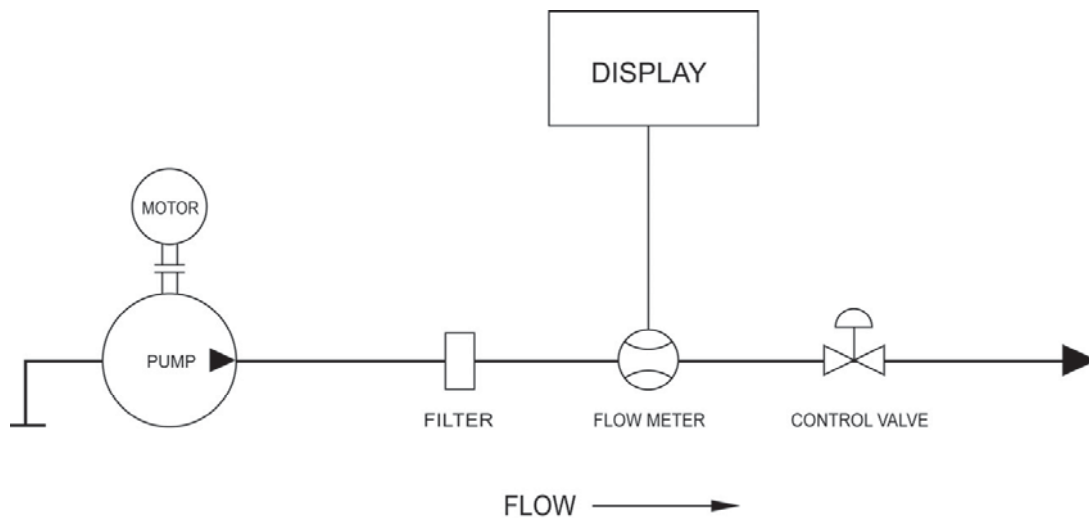

Figure 1

Install the meter upstream from control valves and fluid regulators if possible. See **Figure 1**. Back pressure from control valving is beneficial for stable running.

Eliminate all dirt, debris and metal shavings from the piping as the liquid must be free from any particles larger than allowed by the manufacturer's specifications. Any recommended filtration should be installed before operation as potential plugging most often occurs at startup.

If possible, install a by-pass around the meter and flush existing piping with the appropriate solvent before first use. See **Figure 1**.

Review the pick-up instructional guide prior to installation. Locate the pick-up and wiring away from A/C motors, actuators, heaters, relays, etc. Use only shielded cable and do not take power from the same circuits as other devices. Ensure clean power supplies which utilize a true earth ground. Intrinsic safety barriers must be installed if the circuit is intended to be intrinsically safe.

The pick-up sensor should only be installed hand tight - do not use wrenches or channel locks. Over tightening may cause a dimple to protrude into the meter chamber beneath the pick-up and interfere with the free gear rotation.

Maintenance Guides are provided with the meter and are also available from the factory. These should always be reviewed by personnel prior to attempting any maintenance work. The overwhelming majority of downtime and repairs are the result of breakages due to improper maintenance actions, lack of training or rough handling.

Never run the meter dry or spin with air only. Gear flow meters are precision engineered flow devices and should always be maintained in a clean, lubricated condition with the internals wet at all times. Air and water should not be allowed in contact with the internal parts except in short (1-2 second) cycles as part of an automated flush.

Do not use water for flow testing. The viscosity of water is too low to produce accurate results unless the flow rate is elevated, and the internals would then have to be dried and lubricated to avoid corrosion or scaling. Using a fluid with a viscosity of approximately 30 cSt, such as mineral oil or thinned glycerin, is recommended if calibration of the system is necessary. The preferred calibration fluid would be the actual fluid to be metered.

Do not ramp-up flow to a full flow condition instantaneously. Gear flow meters are rugged, yet precise instruments which will respond almost instantaneously to changes in fluid flow. Normal pulsating flows will not damage the meter and will merely cause the output to be unsteady. However, if flow is repeatedly cycled from zero to full flow instantaneously, fluid shock forces may be significant and may produce premature damage or wear over time. To avoid damage to the system, ramp-up to maximum flow over a few seconds rather than instantaneously and do not inject high flow speeds into an empty meter.

Filtration is recommended to prevent contaminants from entering the meter. Should the meter become plugged, a reduced flow may still be observed from the outlet as fluid pressure will squeeze fluid through the meter. Visual flow does not necessarily mean that the meter's gears are turning. If plugging is caused by

contaminants, then filtering should be installed. If plugging is repeatedly caused by particle build up, then review the cleaning and maintenance procedures in the following section. Because of the vast differences in fluid types and in-plant procedures, there may be some trial and error involved in determining the ideal flushing or cleaning regimen.

A calibration factor (K-factor) is established at the factory on a preferred calibrating fluid. This number is usually accurate for a wide variety of fluids and should not usually be changed. It is provided with the meter either on a Calibration Data Sheet or on a tag attached to the meter. Should it be lost, a copy can be obtained from the factory. A calibration verification procedure is detailed later in this document.

Storage - when the flow meter is idle or stored for any extended period of time, the internals should be thoroughly cleaned with the appropriate solvent, lubricated with a light oil and the ports capped or plugged to prevent drying.

FLOW METER GUIDELINES FOR PAINT OPERATIONS

Before installing, operating or attempting maintenance on a flow meter read the appropriate Maintenance Guide. As with any precision engineered device, the equipment should always be operated and maintained in accordance with the manufacturer's instructions.

Flow meters are designed to flow liquids which assist in cooling and lubrication. Meters should always be closed to air except when air is part of an automated purge cycle. In this case the air segments are typically under 1-2 seconds and are interspersed with lubrication solvent to achieve a scrubbing effect. The air segments are short enough that the meter doesn't dry out. See **Figure 2**. Do not dry paint lines using only pressurized air as this will lead to premature wear.

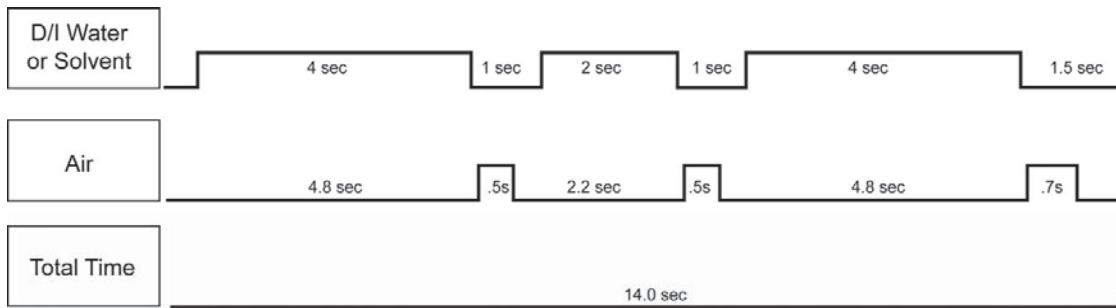

Figure 2

At the end of a shift or overnight, it is strongly recommended that cleaning solvent or DI water with appropriate cutting agent be left in the meter, under pressure, to soak. This helps keep unflushed residual paint from drying and helps subsequent start-ups. Opening a meter after a flush cycle will help determine if the meter is being cleaned thoroughly by the purge.

Regular cleaning cycles with solvent or DI water may be necessary to effect color changes or to prevent some coatings from depositing on critical internal parts. Designing and

maintaining a flush procedure which keeps the meter internals clean and wet is critical to optimum performance and minimum maintenance. Cleaning cycles will vary due to differences in coatings, equipment and cleaning fluids used. Some testing may be prudent to determine the most efficient method. Cleaning cycles using DI water only may require more flushing than those using additives due to the superior cutting ability of solvents. If bells or small orifices restrict adequate purge through the meter, an auxiliary dump valve of 1/4" or 3/8" may be installed after the meter to maximize through flow.

Full flow meter breakdown instructions are included in the Maintenance Guide. When a meter is removed from the line during maintenance, paint should not be allowed to dry inside. The internals should be immediately cleaned, lubricated and the fluid ports capped. Clean the carbide surfaces at the point where the gear rotates on the shaft. Paint build-up here may occur as a thin smear and be difficult to see, but will cause friction and accelerate additional paint build-up later when the gears are reinstalled. Spin the gears by hand to verify free and easy rotation of gear on shaft and apply a suitable lubrication fluid before closing the meter. After tightening the bolts, a short squirt of shop air will briefly spin the gears which should be easily audible. When reinstalling the sensor, turn it in lightly only to a hand tight torque. Do not use a wrench on the pick-up as over tightening may cause damage.

In the event of plugging, the meter will pass a reduced volume of fluid with an increased back pressure and no frequency output. Care during installation is important as this is the most likely time that contaminants such as tape or metal shavings can enter the meter. Filters should be installed in the line to prevent oversize particles from entering the flow meter.

In the event the meter needs to be returned to the factory for further evaluation, flush the meter in place and cap the ports.

TYPICAL AUTOMATED CLEANING CYCLE

At the beginning of the cleaning cycle, clean with DI water for a significant period of time before introducing any air at all into the system. For example, the first thing the meter should see after push out is a relatively long blast of solvent or DI water for at least 3 seconds or more depending on the coating. In the middle of the cleaning cycle, short (0.5 sec) air blasts will maximize the scrubbing effect. At the end of the cleaning cycle, finish with solvent or DI water instead of air. The intention is to put enough purge fluid into the system at this time to have the meter soaking in clean flush fluid at the end of the cycle. When there are gaps in the line or when line stops occur after a color change, following this procedure will keep the meter from potentially freezing up. In general, the meter should never see air for more than a few seconds and should never be run dry. Note: If new paint and purge fluid mixing is a problem, the fill cycle can start with a short 1 second shot of air to separate the purge fluid and the paint.

During line shutdowns, such as overnight and over weekends, meters should be flushed and left filled with solvent, under pressure, to allow any residue that may have built up to soak and dissolve.

Filtration is recommended to prevent contaminants from entering the meter. Should the meter become plugged, a reduced flow will still be observed from the nozzle or outlet as fluid pressure will squeeze fluid through the meter. Should this occur, review the cleaning and maintenance procedures in the following sections.

FLOW METER GUIDELINES FOR PAINT OPERATIONS

- DO:** Leave flushing solvent in the lines overnight or during extended off-times. This keeps internals wet, preventing residual paint from drying and helping start ups.
- DO:** Follow the Maintenance Guide instructions when opening and cleaning a meter. During cleaning, separate the gears from the shafts. On carbide bearings, clean inside the center of the gear bearing and on the outer surface of the shafts at the point where the gear rotates on the shaft. Apply a suitable lubricating fluid before closing the meter. After tightening the bolts, a short squirt of shop air will briefly spin the gears which should be easily audible.
- DO:** Install and maintain filters. The recommended filter should be installed to eliminate potential plugging. Should plugging occur, the meter will still pass fluid but with no signal output.
- DO:** Check electrical compatibility between the meter's output signal and the input of the PLC. If signals are not being detected at start up, first check wiring and electrical compatibility.
- DO:** Verify reliable grounding of electrical parts, as per installation guidelines, and a dedicated power supply is recommended. Voltage spikes on shared power lines, negligent grounding and sloppy wiring will likely produce erratic readings and chronic maintenance. The control valve will provide back pressure which is beneficial to stable flow control.
- DO:** Install the meter immediately upstream of the regulator or control valve. The control valve provides back pressure which stabilizes the flow.
- DON'T:** Allow air into the flow meter. Always keep the meter internally wet.

DON'T: Dry paint lines using pressurized air. Flow meters are designed to flow liquids. Meters should be closed to air except when air is part of an automated purge cycle. Do not dry lines after purging.

DON'T: Allow materials to dry inside the meter. When a meter is removed from the line during maintenance, the internals should be immediately cleaned, lubricated and the fluid ports capped.

DON'T: Over tighten the pick-up sensor beyond hand tight. When installing the pick-up sensor, turn it in lightly to a hand tight torque. Do not use a wrench on the pick-up as over tightening may cause a dimple of metal under the sensor nose to protrude into the gear cavity and interfere with the gear's rotation.

DON'T: Use water or solvent for calibration or test purposes. Water or solvent may not turn the gears at low flow and may leave the impression that the meter is not functioning. A calibration factor (K-factor) is issued with the flow meter which is valid for most fluids except water or equivalent viscosities.

CALIBRATIONS

Each flow meter is calibrated and given a K-factor using a standard calibrating fluid at the factory. This number is accurate for all fluids, with most viscosities, except the most water-like. There should be no need to change this except for the very lowest viscosities close to 1.0 cP.

If flow readings are too high: If the display shows significantly more than the volume actually dispensed or shows flow when there is definitely no flow, this most likely indicates an electrical noise problem. In such cases, turn off nearby motors, heaters or relays, check cable shielding and establish a clean ground independent of other electrical devices before repeating accuracy

tests. If the problem continues, it may be necessary to relocate the offending device.

If flow readings are too low: If the display shows significantly less than the volume actually dispensed, then most likely the meter has a high slippage factor and the fluid is by-passing the gears and the K-factor may require adjustment.

If it is necessary to adjust the existing K-factor: Trigger at least 500ml of your sample fluid, in a steady stream, at approximately the desired flow rate, into a graduated beaker. Compare the volume in the beaker to the volume on the display. Do not time the operation merely measure the volume dispensed. Repeat the sample 3 times and take an average. If the result is outside an acceptable margin, adjust the K-factor by the percentage difference between the average beaker sample and the average displayed total. If the error is not corrected, clean the meter thoroughly and repeat the procedure. Do not use water for this test.

If it is necessary to re-calculate a new K-factor: You will first need a data collecting instrument to count pulses produced by the meter. A Blancett display may be used in totalizer mode provided the KFT is set to count each pulse ($KFT = 10000$). Trigger at least 500ml of your sample fluid, in a steady stream, at approximately the desired flow rate, into a graduated beaker. Divide the number of pulses by the volume dispensed and the result is your new K-factor in the units of your sample. In the example above the K-factor units would be impulses/ml.

TROUBLESHOOTING GUIDE

TROUBLE	POSSIBLE CAUSE	SOLUTION
Meter indicates lower than actual	<ul style="list-style-type: none"> • Viscosity of fluid is <30cSt • Excessive pressure differential across meter causing gears to bind • Debris in measuring chamber • Upper housing has dimple from over tightening sensor 	<ul style="list-style-type: none"> • Decrease the K-factor by percent error • Reduce flow rate, reduce fluid viscosity • Clean meter, change or add filter • Replace upper housing
Meter indicates higher than actual	<ul style="list-style-type: none"> • Air in lines • Electro-magnetic interference • Reverse fluid flow 	<ul style="list-style-type: none"> • Add air eliminator • Ground flow meter and all electronics • Add check valve
Indicator shows flow when there is no flow	<ul style="list-style-type: none"> • Fluid oscillates • Electro-magnetic interference 	<ul style="list-style-type: none"> • Check pump, add check valve, increase back pressure • Ground flow meter and all electronics. Use shielded cable and relocate away from electrical noise.

MAINTENANCE GUIDE FOR THE B175-A/S20 FLOW METER

Cleaning, inspecting or repairing a B175-A/S20 gear flow meter is easily accomplished by following the procedures below.

1. Remove the pickup sensor (not shown) from the flow meter body (5).
2. Remove the hex bolts (6) with a 3/16" key wrench.

3. Re-engage 2 opposing bolts diagonally from each other by a few threads to avoid stress on the shafts and locator pins during housing separation.
4. Holding the upper housing (5), gently tap the opposing bolts (6) to separate the lower housing (1). **Do not use chisels or screwdrivers to split and pry apart the housings - this may damage the gears and locating pins.**

5. After separation, inspect the gears (3) and bearings (7). Carefully remove the gears from the housing and thoroughly clean with solvent. Special care must be observed when cleaning or flushing either the upper housing (5) or lower housing (1). The bearing (7) may dis-lodge from the housing. **There are 1-4 very small shims under each bearing.**

6. After cleaning all parts completely, the gears, bearings and bearing shims can be reinserted into their previous positions. Check for free & easy rotation.

7. Replace O-ring (4) if deformed.

8. Keep meter housings parallel during reassembly and align index marks (8). Both locating pins must be in place (2).

9. Replace hex bolts and slowly tighten to at least 15 Nm. (This is hand tight). Do not force the housing closed. Do not use a hammer. Over tightening will not cause damage but may restrict operation if internal surfaces are not completely clean.

10. After reassembly, gently blow air into meter so gears spin. This should be clearly audible given a moderate background noise level.

11. Clean any debris from the pickup port & hand tighten the pickup sensor. Avoid over tightening as this may damage the meter.

***Do not over tighten sensor ***

12. The bearings should be lubricated prior to storage. Never allow contact with water without immediately drying and lubricating after use.

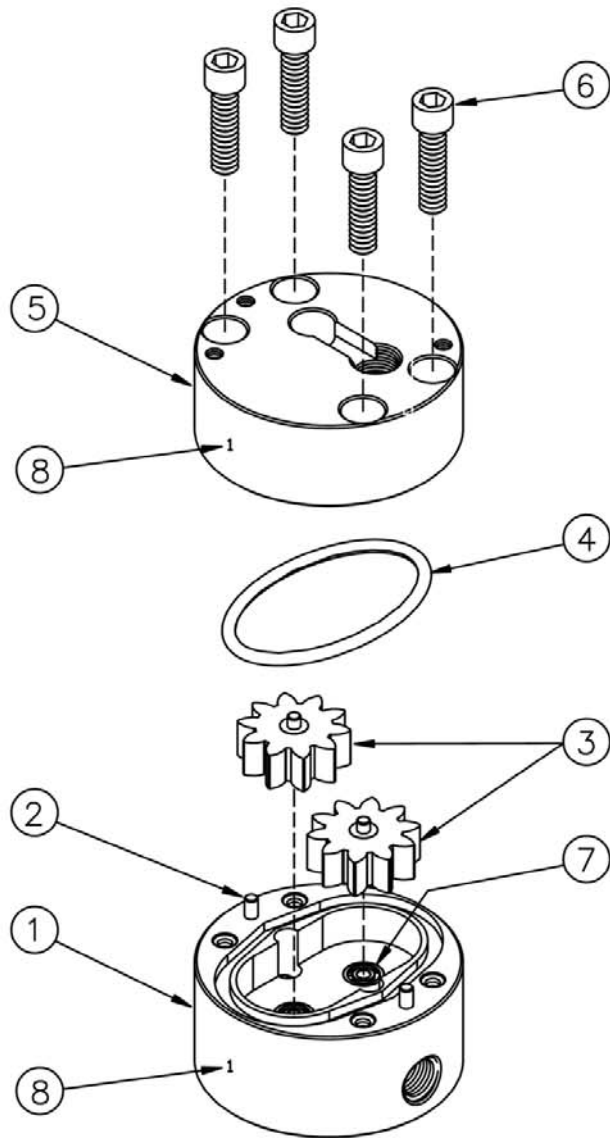

CROSS REFERENCE GUIDE FOR B175-A/S20 SPARE PARTS

1. Lower Housing
Pt.# BJLH-20KL Aluminum Body
Pt.# BJLH-20KL-SS Stainless Body

2. Tool Steel Locating Pins
Pt.# BLP-JV-20KL

3. 416 Stainless Steel Gear
Pt.# BJGR-20KL

4. O-ring
Pt.# COV-02/1 Black Viton O-ring
Pt.# COT-02/1 White Teflon O-ring

5. Upper Housing
Pt.# BJUH-20KL Aluminum Body
Pt.# BJUH-20KL-SS Stainless Body

6. HEX Socket Cap Screw
Pt.# BJSC-15

7. Ball Bearings
Pt.# BB-JVA-20KL

** Not shown**
Shims
Pt.# BJV-SH

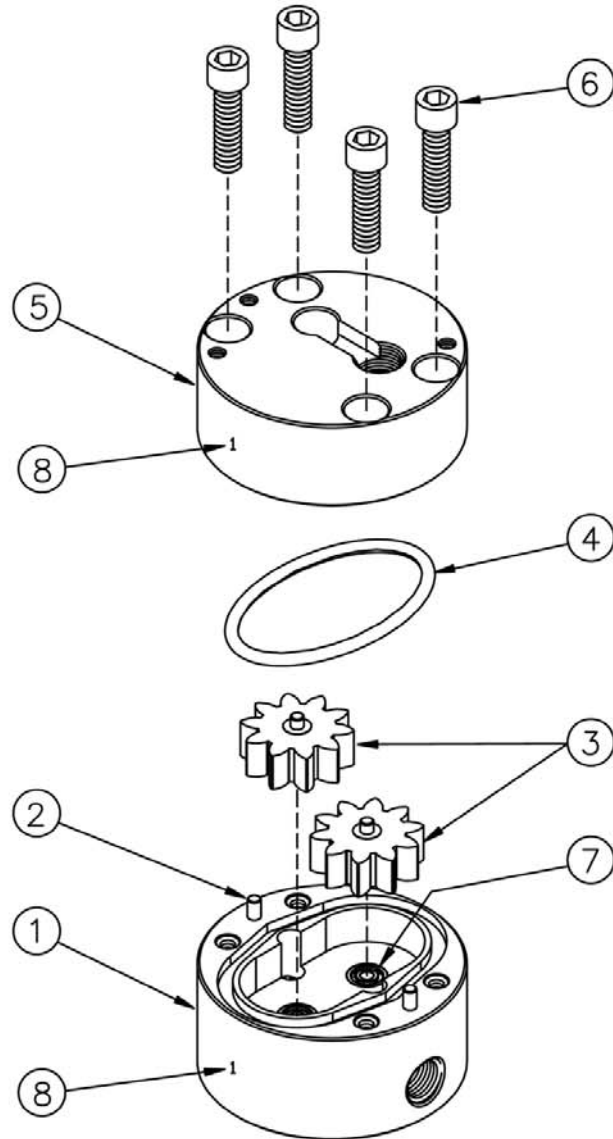

MAINTENANCE GUIDE FOR THE B175-A/S60 FLOW METER

Cleaning, inspecting or repairing a B175-A/S60 gear flow meter is easily accomplished by following the procedures below.

1. Remove the pickup sensor (not shown) from the flow meter body (5).
2. Remove the hex bolts (6) with a 3/16" key wrench.
3. Re-engage 2 opposing bolts diagonally from each other by a few threads to avoid stress on the shafts and locator pins during housing separation.
4. Holding the upper housing (5), gently tap the opposing bolts (6) to separate the lower housing (1). **Do not use chisels or screwdrivers to split and pry apart the housings - this may damage the gears and locating pins.**
5. After separation, inspect the gears (3) and bearings (7). Carefully remove the shims (9) located above & below the gears (3). Inspect and clean the gears taking care not to dislodge the bearings (7) located in the housing. Should the bearings have to be removed take care to locate and replace the shims positioned underneath each bearing. The meter should be recalibrated after any bearing repairs.
6. After cleaning, all parts can be reinserted into their previous positions. Check for free & easy rotation.
7. Replace O-ring (4) if deformed.
8. Keep meter housings parallel during reassembly and align index marks (8). Both locating pins must be in place (2).
9. Replace hex bolts and slowly tighten to at least 15 Nm. (This is hand tight). Do not force the housing closed. Do not use a hammer. Over tightening will not cause damage but may restrict operation if internal surfaces are not completely clean.
10. After reassembly, gently blow air into meter so gears spin. This should be clearly audible given a moderate background noise level.
11. Clean any debris from the pickup port & hand tighten the pickup sensor. Avoid over tightening as this may damage the meter.

*** Do not over tighten sensor ***

12. The bearings should be lubricated prior to storage. Never allow contact with water without immediately drying and lubricating after use.

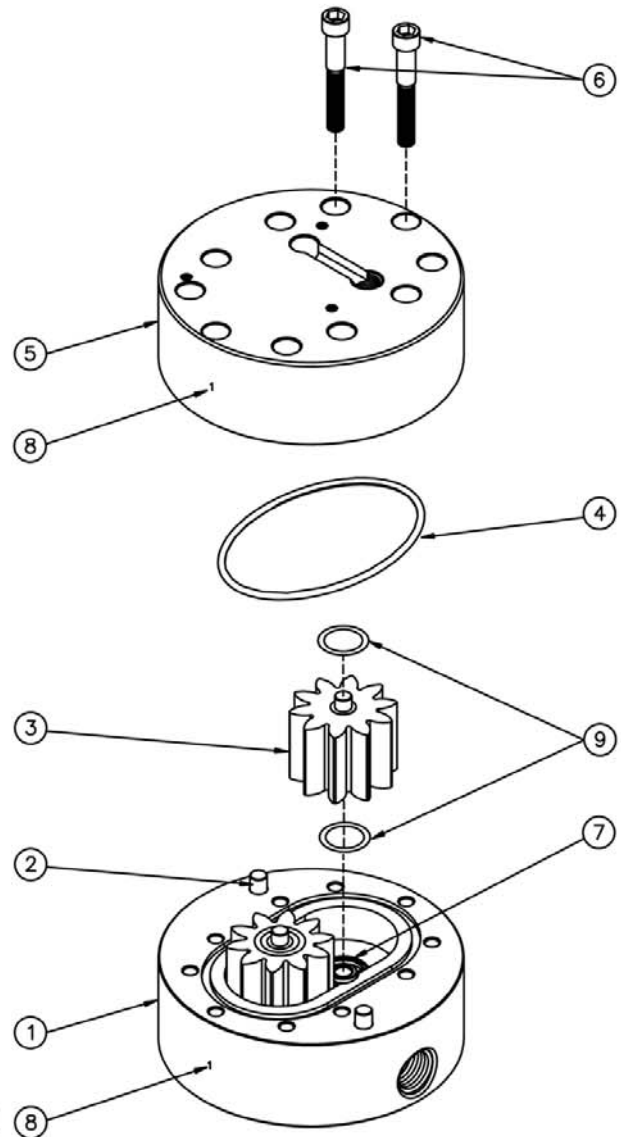

Blancett Flow Meters ■ 8635 Washington Avenue ■ Racine, WI 53406
Tel: 800.235.1638 or 262.639.6770 ■ Fax: 262.417.1155
Technical Toll Free: 877.722.4631

CROSS REFERENCE GUIDE FOR B175-A/S60 SPARE PARTS

1. Lower Housing
Pt.# BJLH-60KL Aluminum Body
Pt.# BJLH-60KL-SS Stainless Body
2. Tool Steel Locating Pins
Pt.# BLP-JV-60KL
3. 416 Stainless Steel Gear
Pt.# BJGR-60KL
4. O-ring
Pt.# COV-JVA-60KL Black Viton O-ring
Pt.# COT-JVA-60KL White Teflon O-ring
5. Upper Housing
Pt.# BJUH-60KL Aluminum Body
Pt.# BJUH-60KL-SS Stainless Body
6. HEX Socket Cap Screw
Pt.# BJSC-60
7. Ball Bearings
Pt.# BB-JVA-60KL
8. Index Marks
9. Shims
Pt.# BJV-SH-60

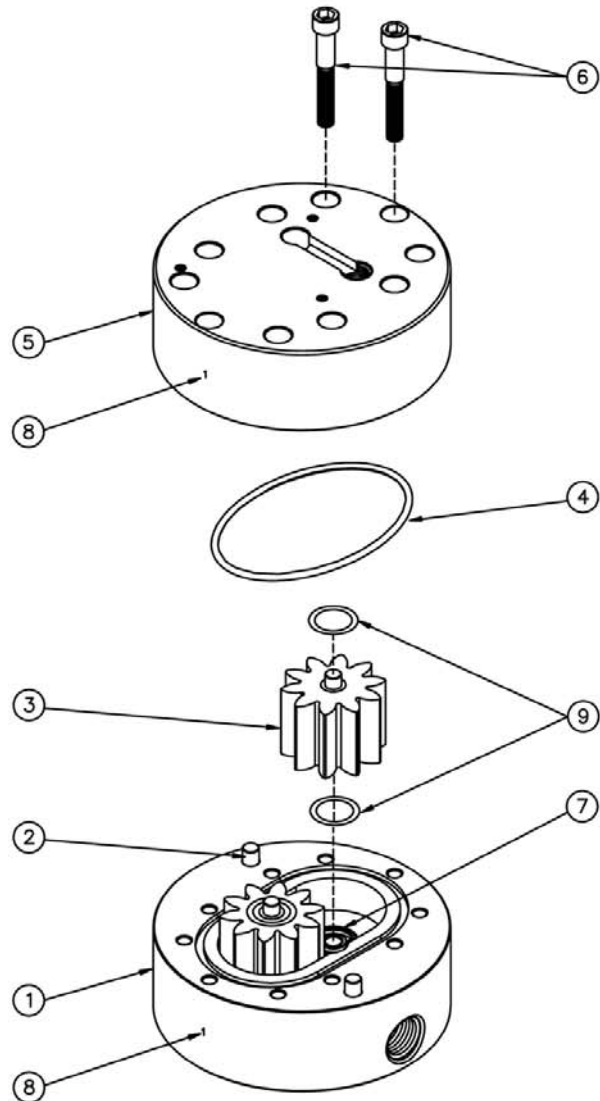

Blancett Flow Meters ■ 8635 Washington Avenue ■ Racine, WI 53406
Tel: 800.235.1638 or 262.639.6770 ■ Fax: 262.417.1155
Technical Toll Free: 877.722.4631

MAINTENANCE GUIDE FOR THE B175-A/S80 FLOW METER

Cleaning, inspecting or repairing a B175-A/S80 gear flow meter is easily accomplished by following the procedures below.

1. Remove the hex bolts (6) with a 3/8" key wrench.
2. Turn 2 bolts into the extraction bolt holes (10) until they make contact with the lower housing. Using these bolts for separating the housings help reduce any stress on the locating pins and gear shafts.
3. With the extracting bolts turned down to the lower housing, give each bolt a half-turn alternately until the housing have separated and the upper housing can be lifted straight off the locating pins. **CAUTION: When lifting the top housing off, make sure the gears stay in the lower housing. If they come out with the top housing, they may fall off and damage the lower housing or the gears themselves.**
4. After separation, inspect the gears (3) and bearings (7). Carefully remove the gears from the housing and thoroughly clean with solvent. Special care must be observed when cleaning or flushing either the upper housing (5) or lower housing (1) as the bearing (7) may dis-lodge from the housing. **Note: Avoid removing the bearings. For bearing repairs the meter should be returned to the factory.**
5. After cleaning add a lubricant if possible, the gears can be reinserted into their previous positions. Check for free & easy rotation.
6. Replace O-ring (4) if deformed.
7. Keep meter housings parallel during reassembly and align index marks (8). Both locating pins must be in place (2). **Note: Make sure to turn out the bolts from the extraction holes (10).**
8. Replace hex bolts and slowly tighten to at least 15 Nm. (This is hand tight). Do not force the housing closed. Do not use a hammer. Over tightening will not cause damage but may restrict operation if internal surfaces are not completely clean.
9. After reassembly, gently blow air into meter so gears spin. This should be clearly audible given a moderate background noise level.
10. The bearings should be lubricated prior to storage. Never allow contact with water without immediately drying and lubricating after use.

Note: The pick-up illustrated is the Quad-80 model (Pt# 170180).

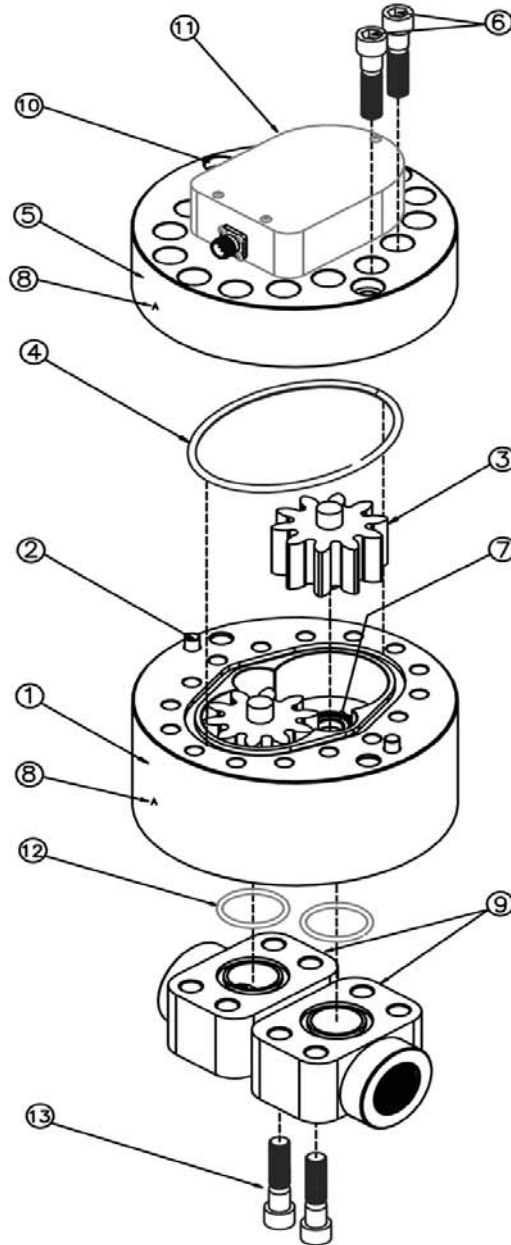

Blancett Flow Meters ■ 8635 Washington Avenue ■ Racine, WI 53406
Tel: 800.235.1638 or 262.639.6770 ■ Fax: 262.417.1155
Technical Toll Free: 877.722.4631

CROSS REFERENCE GUIDE FOR B175-A/S80 SPARE PARTS

1. Lower Housing
Pt.# BJLH-80KL Aluminum Body
Pt.#BJLH-80KL-SS Stainless Body
2. Tool Steel Locating Pins
Pt.#BLP-JVA-80KL
3. 416 Stainless Steel Gear
Pt.# BJGR-80KL
4. O-ring
Pt.# COV-JVA-80KL Brown Viton O-ring
(Standard)
Pt.# COT-JVA-80KL White Teflon O-ring
5. Upper Housing
Pt.# BJUH-80KL Aluminum Body
Pt.# BJUH-80KL-SS Stainless Body
6. HEX Socket Cap Screw
Pt.# BJSC-80-HP
7. Ball Bearings
Pt.# BB-JVA-80KL
8. Index Marks
9. Flange: 13≅ SAE, Code #62 90°, 13≅ NPT
female pipe thread.
Pt.# NPT-JVM-90 (includes 12&13)
10. Extraction Bolt Holes
11. Pickup Sensor
Pt# B170180
Quad-80 is illustrated.
12. Standard Buna-N O-Ring
13. Standard 2-13 UNC Bolt
(Supplied w/flange)

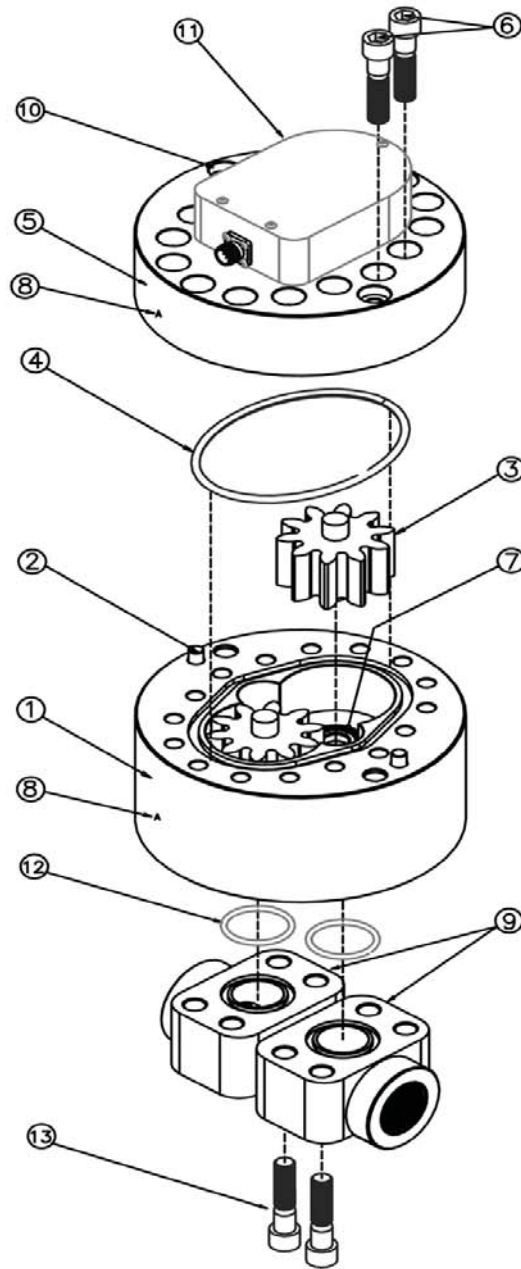

Blancett Flow Meters ■ 8635 Washington Avenue ■ Racine, WI 53406
Tel: 800.235.1638 or 262.639.6770 ■ Fax: 262.417.1155
Technical Toll Free: 877.722.4631

TROUBLESHOOTING GUIDE (cont'd)

TROUBLE	POSSIBLE CAUSE	SOLUTION
No flow indication	<ul style="list-style-type: none"> • No fluid flow • Debris in measuring chamber or gears • Sensor not installed properly • Faulty wiring • Faulty sensor • Upper housing has dimple from over tightening sensor 	<ul style="list-style-type: none"> • Check pump • Clean meter, change or add filter • Check sensor is installed to hand tight. Review sensor guide. • Check sensor connections and readout connection • Replace sensor • Replace upper housing
Erratic system indication	<ul style="list-style-type: none"> • Ground loop in shielding • Pulsating fluid flow 	<ul style="list-style-type: none"> • Ground shield one place only. Re-route cables from electrical noise. • Add pulse dampener

NOTES

STATEMENT OF WARRANTY

Blancett Flow Meters, Division of Racine Federated Inc. warrants to the end purchaser, for a period of one year from the date of shipment from the factory, that all flow meters manufactured by it are free from defects in materials and workmanship. This warranty does not cover products that have been damaged due to defects caused by misapplication, abuse, lack of maintenance, modified or improper installation. Blancett's obligation under this warranty is limited to the repair or replacement of a defective product, at no charge to the end purchase, if the product is inspected by Blancett and found to be defective. Repair or replacement is at Blancett's discretion. A return goods authorization (RGA) number must be obtained from Blancett before any product may be returned for warranty repair or replacement. The product must be thoroughly cleaned and any process chemicals removed before it will be accepted for return.

The purchaser must determine the applicability of the product for its desired use and assumes all risks in connection therewith. Blancett assumes no responsibility or liability for any omissions or errors in connection with the use of its products. Blancett will under no circumstances be liable for any incidental, consequential, contingent or special damages or loss to any person or property arising out of the failure of any product, component or accessory.

All expressed or implied warranties, including **the implied warranty of merchantability and the implied warranty of fitness for a particular purpose or application are expressly disclaimed** and shall not apply to any products sold or services rendered by Blancett.

The above warranty supersedes and is in lieu of all other warranties, either expressed or implied and all other obligations or liabilities. No agent or representative has any authority to alter the terms of this warranty in any way.

Blancett

8635 Washington Avenue • Racine, Wisconsin 53406

Sales Toll-Free: 800.235.1638

Phone: 262.639.6670 • Fax: 262.417.1155

www.blancett.com

RFI Racine Flow Meter Group ***Blancett*** **DYNASONICS** **Flo-tech** **HEDLAND** **PRESO** **racine**

BLANCETT is a registered trademark of Racine Federated Inc.
UL is a registered trademark of Underwriters Laboratories.
© 2012 Racine Federated Inc.

Printed in USA
Form # 02-PDM-UM-00108
Rev 04/12