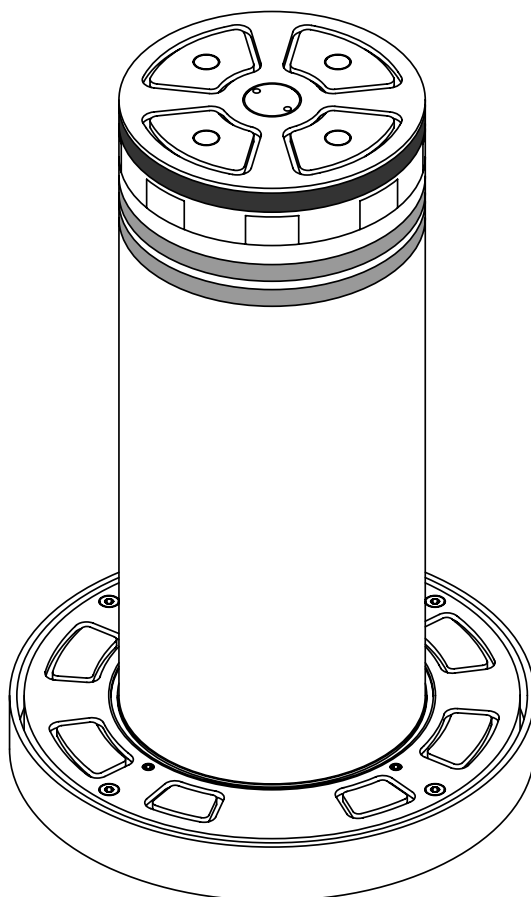


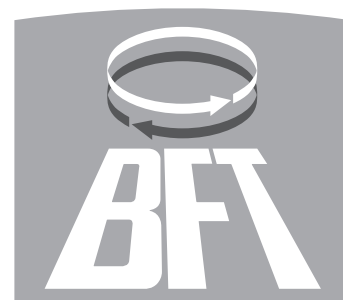


STOPPY - STOPPY H



**AZIENDA CON SISTEMA DI GESTIONE
INTEGRATO CERTIFICATO DA DNV
= UNI EN ISO 9001:2000 =
UNI EN ISO 14001:2004**

Via Lago di Vico, 44
36015 Schio (VI)
Tel.naz. 0445 696511
Tel.int. +39 0445 696533
Fax 0445 696522
Internet: www.bft.it
E-mail: sales@bft.it



to be used in particularly cold climates (as much as -25°C) and "A" series provided with a magnetic sensor for connection to an antitheft system.

Accessories:

Electric brake buffer battery kit, which allows the bollard to be kept in the access closed position even when the mains power is off.

2) SAFETY

If correctly installed and used, this automation device satisfies the required safety level standards. However, it is advisable to observe some practical rules in order to avoid accidental problems.

Before using the automation device, carefully read the operation instructions and keep them for future reference.

- Keep children, persons and things outside the automation working range, particularly during operation.
- Keep radio controls or other control devices out of children's reach, in order to avoid any unintentional automation activation.
- Do not intentionally oppose the rod movement.
- Do not modify the automation components.
- In case of malfunction, activate the cut-out switches to disconnect the power supply, batteries included, in order to gain access to the automation device, and request the assistance of a qualified person (installer).
- Before proceeding to any external cleaning operation, activate the cut-out switches to disconnect the mains powers supply and the batteries, if provided.
- Keep the photocell optical components and light signal devices clean. Check that none of the safety devices (photocells) are obscured by branches or shrubs.
- For any direct assistance to the automation system, request the help of a qualified person (installer).
- Have qualified personnel inspect the automation system once a year.

3) MANUAL MANOEUVRE

When the power supply is disconnected, the bollard tends to lower spontaneously, therefore carrying out an opening manoeuvre; a simple pressure exerted on the top of the cylinder surface will complete lowering, and vehicle transit will be allowed. See fig. 1.

N.B. opening means bollard lowered (transit allowed), closing means bollard raised (transit not allowed)

In the case of bollards provided with buffer batteries, before proceeding to manual manoeuvre, disconnect the emergency power supply by means of the appropriate switch fitted by the installer.

4) MAINTENANCE AND SCRAPPING

System maintenance is to be regularly carried out by qualified personnel. The materials making up the appliance and its packing are to be scrapped according to current standards. Batteries must be disposed of in the appropriate manner.

WARNING

Correct operation of the controller is only guaranteed when the data specified in this manual are respected, as well as good technical practice standards. The Company cannot be held responsible for any damage caused by failure to observe the installation standards, good technical practice standards and directives specified in the present manual.

The descriptions and illustrations contained in the present manual are not binding. The Company reserves the right to make any alterations deemed appropriate for the technical, manufacturing and commercial improvement of the product at any time, while leaving the essential product features unchanged.

Thank you for buying this product, our company is sure that you will be more than satisfied with its performance. This product is supplied with a "Warnings" leaflet and an "Instruction Manual". These should both be read carefully as they provide important information about safety, installation, operation and maintenance. This product complies with recognised technical standards and safety regulations. We declare that it is in conformity with the following European Directives: 2004/108/EEC, 2006/108/EEC, 2006/42/EEC (and subsequent amendments).

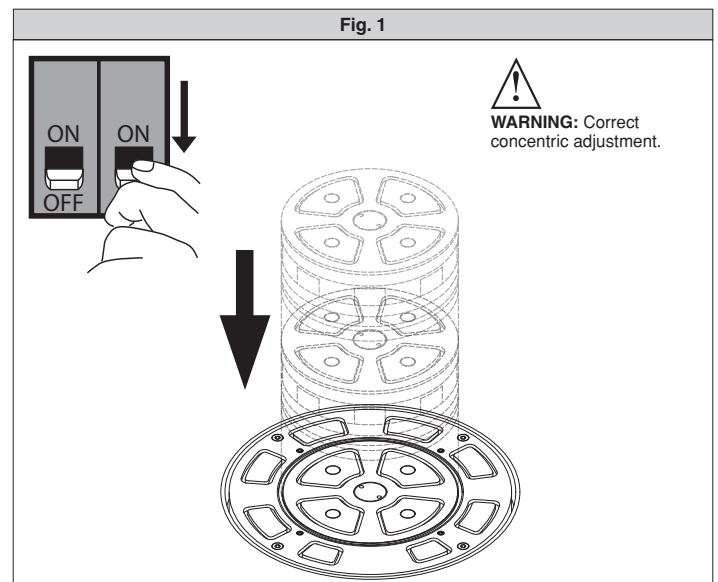
1) GENERAL OUTLINE

Underground anti-waiting bollard, compact and sturdy. It consists of a steel rod coated with reflecting material, and powered by an oil-bath motor. Entirely protected by a steel cylinder with cathoporesis coating which should be fitted underground.

The **PERSEO 2** control panel allows up to four bollards to be controlled simultaneously.

In addition to the base STOPPY version, series "L" models, equipped with blinking signal lights, the approved version series "O" models and series "F" models with permanent anti-transiting bollard are also available.

On request, "R" series provided with a heated resistor which also allows the bollard



Thank you for buying this product, our company is sure that you will be more than satisfied with its performance. This product is supplied with a "Warnings" leaflet and an "Instruction Manual". These should both be read carefully as they provide important information about safety, installation, operation and maintenance. This product complies with recognised technical standards and safety regulations. We declare that it is in conformity with the following European Directives: 2004/108/EEC, 2006/108/EEC, 2006/42/EEC (and subsequent amendments).

1) GENERAL SAFETY

WARNING! An incorrect installation or improper use of the product can cause damage to persons, animals or things.

The Company declines all responsibility for any consequences resulting from improper use of the product, or use which is different from that expected and specified in the present documentation.

- The "Warnings" leaflet and "Instruction booklet" supplied with this product should be read carefully as they provide important information about safety, installation, use and maintenance.
- Scrap packing materials (plastic, cardboard, polystyrene etc) according to the provisions set out by current standards. Keep nylon or polystyrene bags out of children's reach.
- Keep these installation instructions together with the technical brochure for future reference.
- This product was exclusively designed and manufactured for the use specified in the present documentation. Any other use not specified in this documentation could damage the product and be dangerous. The Company declines all responsibility for any consequences resulting from improper use of the product, or use which is different from that expected and specified in the present documentation.
- Do not install the product in potentially explosive atmosphere or wherever there is a fire risk.
- The construction components of this product must comply with the following European Directives: 2004/108/CEE, 2006/108/EEC, 2006/42 EEC and subsequent amendments. As for all non-EEC countries, the above-mentioned standards as well as the current national standards should be respected in order to achieve a good safety level.
- The Company declines all responsibility for any consequences resulting from failure to observe Good Technical Practice when installing the device described in the present manual.
- The installation must comply with the provisions set out by the following European Directives: 2004/108/CEE, 2006/108/EEC, 2006/42 EEC and subsequent amendments.
- Disconnect the electrical supply before carrying out any work on the installation. Also disconnect any buffer batteries, if fitted.
- Fit an omnipolar or magnetothermal switch on the mains power supply, having a contact opening distance equal to or greater than 3,5 mm. Also fit an adequate cut-out device for the buffer batteries.
- Check that a differential switch with a 0.03A threshold is fitted just before the power supply mains.
- Check that earthing is carried out correctly: connect all metal parts of the closing mechanism and all system components provided with an earth terminal.
- Fit all the safety devices (photocells, electric edges etc.) which are needed to protect the area from any danger caused by squashing, conveying and shearing.
- Position at least one luminous signal indication device (blinker) where it can be easily seen, and fix a Warning sign next to the structure.
- The Company declines all responsibility with respect to the automation safety and correct operation when other producers' components are used.
- Only use original parts for any maintenance or repair operation.
- Do not modify the automation components, unless explicitly authorised by the Company.
- Instruct the product user about the control systems provided and the manual opening operation in case of emergency.
- Do not allow persons or children to remain within the automation operation area.
- Keep radio control or other control devices out of children's reach, in order to avoid unintentional automation activation.
- The user must avoid any attempt to carry out work or repair on the automation system, and always request the assistance of qualified personnel.
- Anything which is not expressly provided for in the present instructions, is not allowed.
- Installation must be carried out using the safety devices and controls prescribed by the EN 12978 Standard.

2) GENERAL OUTLINE

Underground anti-waiting bollard, compact and sturdy.

It consists of a steel rod coated with reflecting material, and powered by an oil-bath motor.

Entirely protected by a steel cylinder with cataphoresis coating which should be fitted underground.

The **PERSEO 2** control panel allows up to four bollards to be controlled simultaneously.

In addition to the base STOPPY version, series "L" models, equipped with blinking signal lights, the approved version series "O" models and series "F" models with permanent anti-transiting bollard are also available.

On request, "R" series provided with a heated resistor which also allows the bollard to be used in particularly cold climates (as much as -25°C) and "A" series provided with a magnetic sensor for connection to an antitheft system.

Accessories:

Electric brake buffer battery kit, which allows the bollard to be kept in the access closed position even when the mains power is off.

3) TECHNICAL SPECIFICATIONS FOR STOPPY ACTUATOR

Motor:	230V ~ ±10% 50/60 Hz*
Capacitor:	10 µF
Power input	270 W
Limit switch	magnetic reed sensor
Absorption:	1.4 A (230V) 2.4 A (110V)
Work frequency:	1500/24h
Operating force:	700 N (~70 kg)
Degree of protection:	IP67
Control panel	PERSEO 2
Electric brake:	24V ---
Working time:	6s+slow-down**
Working temperature	-15°C + 60°C
Working temperature for "R" versions	-25°C + 60°C
Front impact resistance on rod raised by 350 mm:	8,000 Joule (50% breakage possibility)
Front impact resistance on rod raised by 350 mm "O" version:	10,500 Joule (50% breakage possibility)
Static Load:	Max. sustainable weight with raised rod: 300kg Max. sustainable weight with lowered rod: 15,000 kg
Dynamic Load:	Max. raising force : 100kg
Weight:	90 kg ca.***
Dimensions :	see fig. 1
Manual manoeuvre:	When the current is off, it becomes reversible.

(* other voltages available on request)

(** 9s+slow-down STOPPY H)

(*** 110 kg ca. STOPPY H)

4) TECHNICAL SPECIFICATIONS FOR PERSEO 2 CONTROL PANEL

Power supply:	230V ~ ±10% 50/60Hz*
Absorbed current:	6A max (with 4 bollards)
Maximum no. of motors:	up to 4 STOPPY bollards (Fig.8)
Dimensions:	see figure 4
Fuses:	F1: T6.3 A / F2: T315 mA / F3: T2A / F4: T2A

(* other voltages available on request)

5) PRELIMINARY CHECKS

Check that the installation base is stable and level.

For correct operation, the bollard does not require precise verticality; however, to obtain a good aesthetic result, it is advisable to proceed to levelling the installation area so as to ensure that the rod stroke is perfectly vertical.

6) FOUNDATION DIGGING AND BOLLARD POSITIONING

- Proceed as shown in fig. 2.
- Carry out electrical installation (see paragraph 7).

7) ELECTRICAL INSTALLATION SET-UP

Lay out the electrical installation as shown in fig. 3, making reference to the current CEI 64-8, IEC 364 (HD 384 harmonised) electrical standards, and other national standards.

WARNING! For connection of the control panel to the mains, use a multicolour cable having a minimum 3x1.5 sq mm cross section of the type set out by the current standards. For example, if the cable is installed outside (in the open air), it must be at least equal to H07RN-F, whereas, if it is installed inside (in a raceway), it must be at least equal to H05 VV-F and have a 3x1.5 sq mm cross section.

To connect the bollard to the control panel, use cable supplied as standard and already wired inside the bollard. Should the cable be too short, join it inside a watertight box, using two separate cables for low voltage and mains voltage connections.

Particular attention must be paid in separating and fixing the wiring, so that the low voltage and mains voltage cables are prevented from coming into contact.

Connect the control and safety devices in compliance with the installation technical standards mentioned previously.

Fig.3 shows the number of connections and their cross section for an approximate

length of 100 metres: in case of longer cables, calculate the cross section for the true automation load.

Example of installation:

I	Type-approved omnipolar circuit breaker, which must be adequately rated and have at least 3,5 mm contact opening, provided with protection against overloads and short circuits. If not already installed, place a type-approved differential switch with a 0.03A threshold just before the automation system.
QR	Control panel and incorporated receiver
S	Key selector
AL	Blinker with tuned antenna
M	Bollard
P	Wall-mounted pushbutton panel
Fte, Fre	Pair of photocells
T	1-2-4 channel transmitter
SF	Red and green traffic lights
SM	Magnetic coil

NOTE: The choice of the type and number of safety devices to be installed depends on the particular use and installation location.

8) TERMINAL BOARD CONNECTIONS

Having passed adequate electric cables through the raceways, and fixed the various automation components in the chosen points, these must be connected according to the indications given in the diagrams below.

Carry out connection of the phase, neutral and earth (compulsory) wires. The protection (earth) wire with yellow/green insulating sheath must be connected to the appropriate terminals marked by the earthing symbol.

The automation system must only be commissioned after all the safety devices have been connected and inspected.

Here follows the description of the **PERSEO 2** mod. control unit supplied as standard (fig. 4).

CN1

1-2 Single-phase mains supply (1=L) (2=N)

3-4-5 Motor connection (3 opening - black wire, 4 common - blue wire, 5 closing - brown wire) up to 4 motors in parallel
N.B. opening means bollard lowered (transit allowed), closing means bollard raised (transit not allowed)

6-7-8 Traffic light output (6 green, 8 red, 7 common) 230V 25+25W max

9-10 Blinker output 230V

CN2

11-12 Electric brake outputs 24V $\overline{\text{---}}$ (up to 4 in parallel) white wires

13-14 Buffer battery board input at 12 Vd.c. to maintain electric brake with mains power off

15-16 STOPPY signalling LED outputs 24V~ (up to 4 in parallel) 0.8 A max yellow wires

17-18 AUX BOLLARD HORN OPTION:

To power the bollard horn, jumper terminals 18-19 and connect the two pink cables to terminals 17-20 (Fig. 4).

19-20 Supply to accessories 24 V~ 1 A max

CN3

21-22 Photocell input (NC contact) active on closing

23-24 Stop command input (NC contact) - stops the manoeuvre and leaves the bollard released. A subsequent Start command always activates bollard opening, unless already opened, in which case it controls closing.

Opening limit switch input - green wires

24-25 Start command input (NO contact, 2-step logic: open-close) - with the bollard raised, the Start command initiates the lowering manoeuvre, during which this command is not active; with the bollard lowered, the Start command initiates the manoeuvre, and during rod raising, a new Start command interrupts the manoeuvre and controls lowering.

27-29 Open command input (NO contact)

The contact "open" also acts as safety device in that, after the bollard has been lowered, it deactivates the closing and start command, interrupting also the automatic re-closing until it is released.

28-29 Close command input (NO contact)

30-31 CN4 Heating resistor

Terminal preset for supplying the heating resistor (230V~100W max) on the "R" series models. Allows the bollard to be used even in particularly cold climates. However, even with the heating resistor installed, it may be necessary to remove any layers of ice which have formed on the bollard surface (red wires).

Antitheft device

Presetting of reed sensor located on the flange of the "A" series bollard. Allows the bollard to be connected to an external antitheft device. In the case of an attempt to tamper with the bollard, the sensor activates the alarm system (orange wires, NC contact).

CN8 Radio Receiver

Connection for single and double-channel radio receiver

The second channel is always connected to the close command (see dip-switch 5 configuration).

The first channel can be configured, by means of the J1 jumper (see fig. 4), as:

- **Start with 2-step logic: open-close**

see Start command description in the paragraph concerning terminal board connections.

- **Open**

only accepts the opening command.

To control closing and opening by means of two different keys on a double-channel transmitter, use a double-channel receiver and move the J1 jumper on the PERSEO 2 control panel to the Open position.

34-35 CN9 Antenna

Antenna input (35 signal, 34 braid). RG58 Cable.

21-28-29 CN3 Dead man control

The bollard lowering is semi-automatically controlled, whereas the switch should be pressed to raise it.

A warning light connected to the electric brake output signals (terminals **11-12**) that raising has ended.

The raising control switch can be released when the warning light comes on.

Regulations prohibit controls via radio with dead-man logic

The components - Heating resistor (red cables), Electric brake (white cables), LED lights (yellow cables), Opening limit switches (green cables) and Anti-theft contact (orange cables) - are not polarised, therefore the position of the cables of the same colour is interchangeable.

9) CONNECTION TO SEVERAL MOTORS

Refer to Fig. 9 for the connection to several motors.

The motor capacitors must be connected in parallel. To do this, cut the CM connector of the capacitor and use an auxiliary external terminal board.

The limit switches must be connected in series as indicated in Fig. 9. The electric brakes must be connected in parallel as indicated in Fig. 9. The connections must be completed in a workmanlike manner.

DIP-SWITCH CONFIGURATION

1-2-3 T LAVORO



LEAVE THE DIP1-3 OFF!

DIP2 device select

OFF = STOPPY

ON = STOPPY H

4 TCA

Enables subsequent automatic closing

OFF= excluded

ON= dwell time to be entered and set by means of appropriate trimmer (dwell time) from 2s to 120s

5 IBL TCA

Enables Start and Close commands during dwell time

OFF= disabled

ON= enabled

6 IBL OPEN

Start command only valid when activated after Open command

OFF= independent inputs

ON= restricted inputs

7 IBL CLOSE

Closing command

OFF= impulse activated

ON= impulse released

8 PRELAMP

Pre-flashing function on flashing light, traffic light and AUX output

OFF= excluded

ON= Before each lowering phase, it activates the flashing light and the AUX output for 2 seconds and before each raising phase it activates the flashing light and the AUX output (adjustable with AUX trimmer) and alternates the green and red lamps of the traffic light for 0 to 10 seconds.

9 LED OPEN

Operation of LED lights with bollard raised

OFF= fixed lights

ON= blinking at 1s

10 LED CLOSE

Operation of LED lights with bollard lowered

OFF= fixed lights

ON= blinking at 0,5s

TRIMMER SETTING

T AUX It adjusts the duration, from 0 to 10 seconds, of the pre-flashing function of the flashing light, traffic light and activation of the clean AUX contact between terminals 17-18 before the bollard rises.

V RALL Sets the approaching speed towards the mechanical closing limiting

device (on opening the slow-down is steady).

TPAUSA Sets the dwell time from 2s to 120s.

10) CONCENTRICITY SETTING UP

For correct operation, proceed to setting up the cylinder concentricity in order that, during the opening and closing manoeuvres, movement occurs smoothly, regularly and without oscillation. To set up the cylinder, proceed as follows:

Use a no.4 Allen key to unscrew and remove dowels A (fig. 5).

Insert a no.3 flathead screwdriver (DIN 0,8x5) and turn it one way or the other until obtaining concentricity (fig. 5).

During this phase concentricity can be checked visually, making sure that the distance between the cylinder and external flange is as uniform as possible.

Then proceed to a practical check, carrying out a few manoeuvres during which the cylinder movement can be checked.

Screw the 4 dowels in tight.

WARNING! Concentricity is very important for the correct operation and life of the actuator; it is to be first calibrated during the installation phase, checked after 6 months and then every year.

Operation with marked eccentricity could lead to deterioration of the rod seals.

11) DISASSEMBLY

Should it be necessary to gain access to the bollard internal components or motor, refer to fig. 6 and proceed as follows:

- 1 Disconnect the electrical supply before carrying out any operation on the system. Also disconnect any buffer batteries, if fitted.
- 2 Use a no.6 Allen key to unscrew and remove 4 external screws A, and a no.4 Allen key to remove dowels B.
- 3 Remove external flange C.
- 4 Use special wrench D (supplied) to unscrew and remove central block E.
- 5 Use a no.13 socket spanner to unscrew and remove underlying nut F and respective washers.
- 6 At this point, use a small screwdriver as a lever on the junction between cylinder and cap to remove the upper part of cylinder G.
- 7 If the model is supplied with signal indication lights, these must be disconnected. Then unscrew piston pin H, and subsequently the Faston connections.
- 8 Take out cylinder I, using a cable or a hook passing through the upper cylinder holes.

Do not place your hands in the upper holes to take out or put back the cylinder (the presence of centre pin L could cause injuries). Withdraw the signal light connection cable from the cylinder.

- 9 Withdraw 4 adjustment pins M from supports N, and then withdraw supports N from adjustment bracket O.
- 10 It is now possible to take out the entire motor unit and proceed to any inspections or repairs needed.

12) ASSEMBLY

- 1 Check that adjustment brackets O are completely screwed onto lower bracket P, in order that it might be easier to set up concentricity after assembly is completed.
- 2 Reposition the motor unit on the bottom of the cylinder, making sure that the cable is not squashed under the lower plate. For this purpose, we advise you to tie a wire to the cable to keep it raised during motor positioning; later you can proceed to arrange the exceeding cable under upper flange Q, so that it does not interfere with the rod stroke. Also check the alignment of adjustment pins M with reference to the holes in the cylinder, in order for positioning of flange C to take place without any problems.
- 3 Proceed to repositioning 4 supports N on the adjustment brackets, as well as adjustment pins M.
- 4 Insert cylinder I, using a cable or a hook passing through the upper cylinder holes. **Do not place your hands in the upper holes to take out or put back the cylinder** (the presence of central pin L could cause injuries). In the case of bollards supplied with signal lights, provide for the power supply cable to pass through (this operation can be made easier by tying a wire to the connection pin). Mechanical end-of-stroke R is fitted to the bottom of the cylinder; during re-assembly, the position of the end-of-stroke referred to sensor S must be respected. In the case of bollards provided with alarm sensors, pay attention to the position of magnet T fitted to the flange, which must coincide with the position of sensor U fixed to the cylinder.
- 5 Reconnect the light supply Faston connections and retighten piston pin H. The signal indication lights are not polarised, therefore the position of the contacts is irrelevant.
- 6 Reposition the upper part of cylinder G and fix nut F by means of a no.13 socket spanner.
- 7 Use special wrench D to screw central block E.
- 8 Use a no.6 Allen key to tighten 4 external screws A, and a no.4 Allen key to tighten dowels B.

WARNING! After each disassembly and assembly operation, proceed to checking concentricity.

13) MANUAL MANOEUVRE

When the power supply is disconnected, the bollard tends to lower spontaneously, therefore carrying out an opening manoeuvre; a simple pressure carried out on the top cylinder surface will complete lowering, and vehicle transit will be allowed. See fig. 8.

To prevent the cylinder from lowering when the mains power is off, a buffer battery system is required. In this case, the installer must fit a battery cut-out switch, in order to allow manual manoeuvre to be carried out when the mains power is off.

The installer undertakes to instruct the user on correct automation use, highlighting the operations to be carried out in case of emergency.

14) MALFUNCTIONS. CAUSES AND REMEDIES

- If the bollard does not move smoothly, proceed to setting up concentricity (see paragraph 9).
- If the rod does not move up, check that the mains power supply is on, any buffer batteries supplied are efficient, and the fuses are in good condition; also check the motor connections to the control panel.
- If the rod does not move down, it is probable that an Open command is constantly given from the control panel or other external device. Therefore temporarily disconnect all the external devices in order to identify the cause of the problem. If the rod still remains raised, proceed to disconnecting the power supply and then checking the control panel. Anyway, when the power supply is off, the rod should spontaneously tend to lower; if this does not happen, proceed to disassembly (paragraph 10) in order to identify any mechanical problems preventing the lowering manoeuvre.

15) DISMANTLING

When the automation device is disassembled to be reassembled on another site, proceed as follows:

- Disconnect the power supply and the entire electrical installation
- Remove the bollard, taking care not to damage the sheath which is to protect the electric cables during the digging operations.
- Disassemble the control panel and all the installation components.
- In the case where some of the components cannot be removed or are damaged, they must be replaced.

16) MAINTENANCE AND SCRAPPING

System maintenance is to be regularly carried out by qualified personnel. The materials making up the appliance and its packing are to be scrapped according to current standards. Batteries must be disposed of in the appropriate manner.

WARNING

Correct operation of the controller is only guaranteed when the data specified in this manual are respected, as well as good technical practice standards. The Company cannot be held responsible for any damage caused by failure to observe the installation standards, good technical practice standards and directives specified in the present manual.

The descriptions and illustrations contained in the present manual are not binding. The Company reserves the right to make any alterations deemed appropriate for the technical, manufacturing and commercial improvement of the product at any time, while leaving the essential product features unchanged.

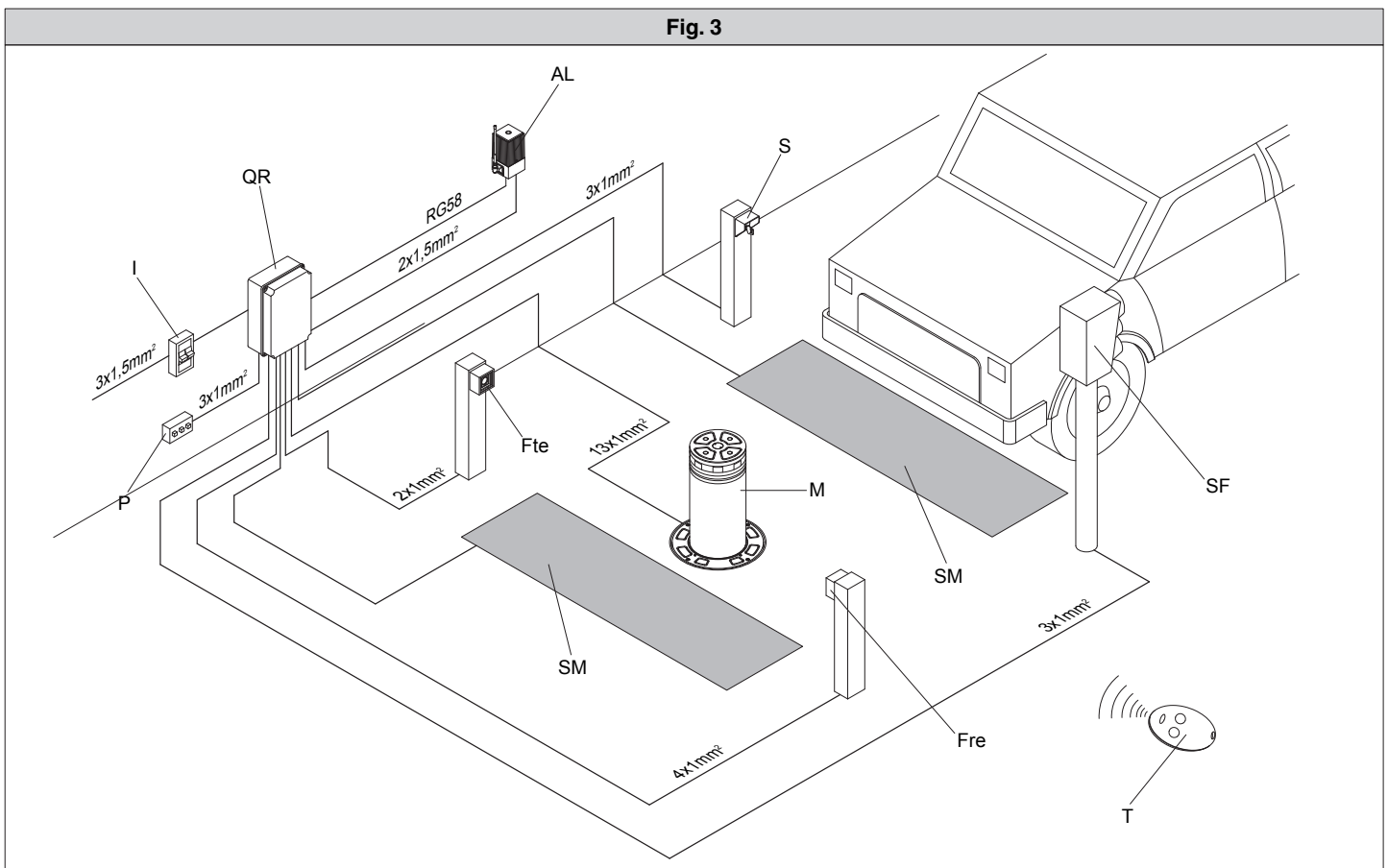
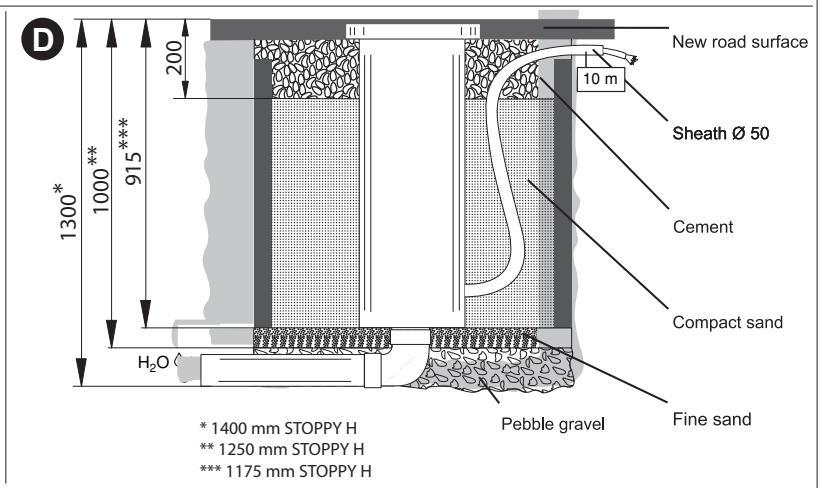
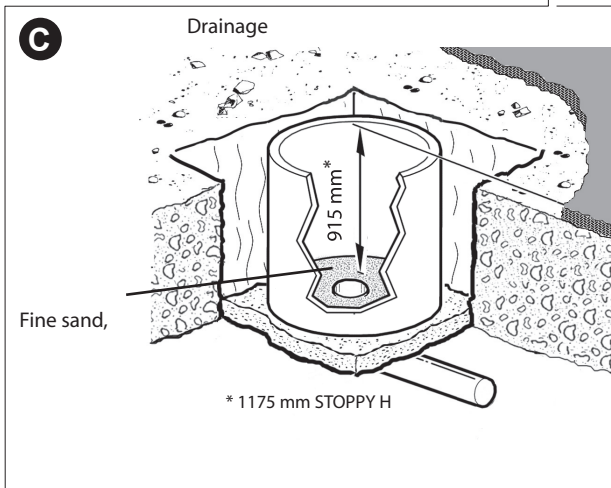
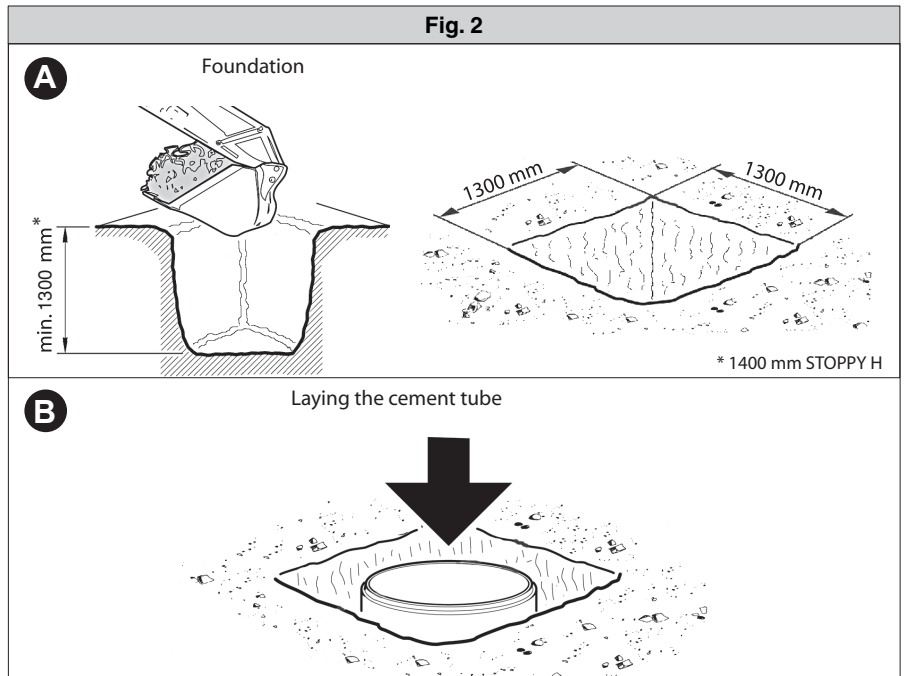
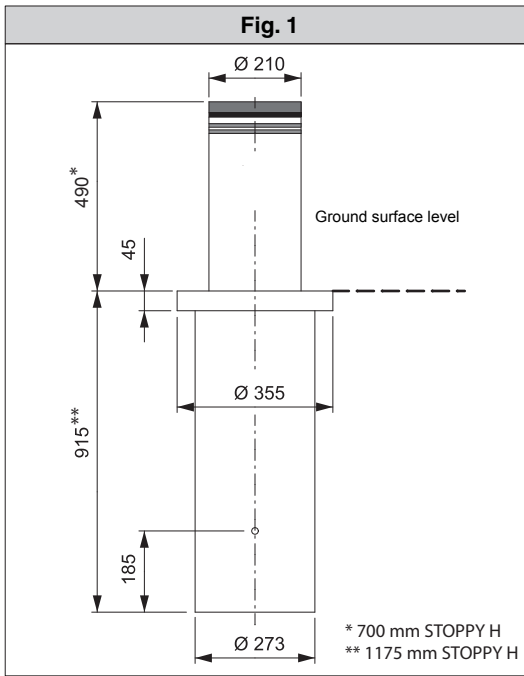
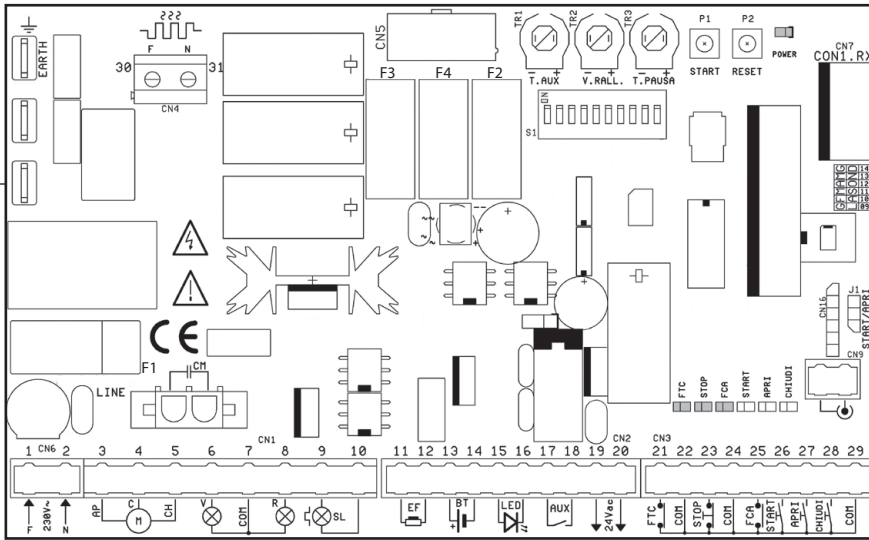
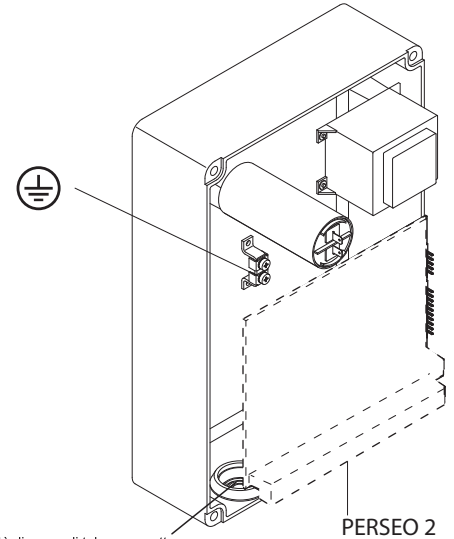


Fig. 4



PERSEO 2



STOPPY GND

Yellow-Grene

- Disponibilità di raccordi tubo - cassetta:
CRTR (raccordo con tubo rigido)
CRTL (raccordo con guaina flessibile)
 Available couplings connecting the pipes to the box:
CRTR (coupling with rigid pipe)
CRTL (coupling with flexible sheath)
 Disponibilit  de raccords tube - bo te:
CRTR (raccord avec tube rigide)
CRTL (raccord avec tuyau souple)
 Erh tliche Rohrverschraubungen f r Steuerungsgeh use
CRTR (Verbindungsst ck f r starres Rohr)
CRTL (Verbindungsst ck f r flexibles Rohr)
 Disponibilidad de uniones tubo - caja:
CRTR (unión con tubo rigido)
CRTL (unión con vaina flexible)

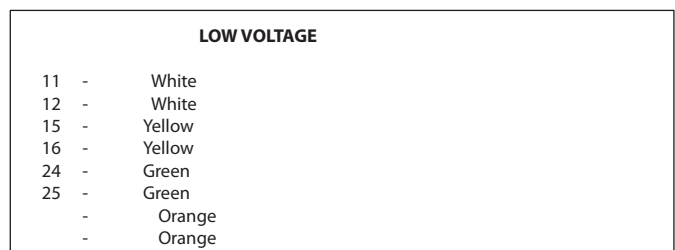
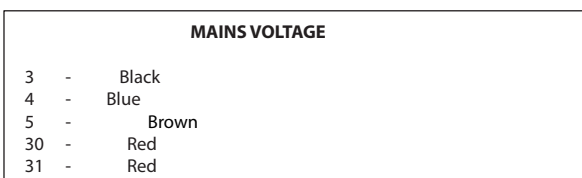
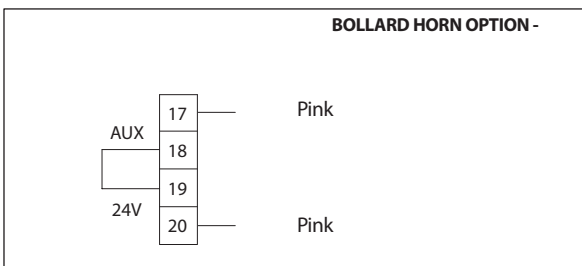
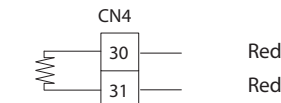
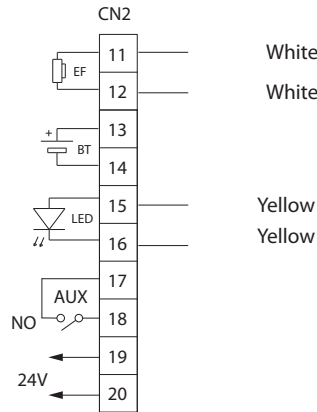
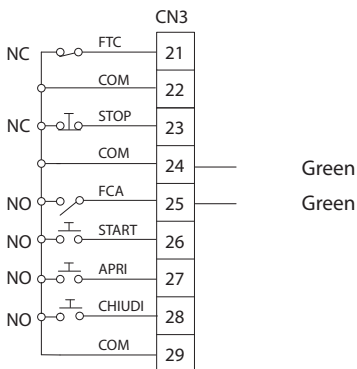
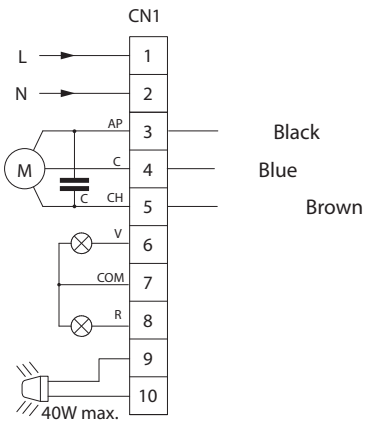


Fig. 5

D811753_02

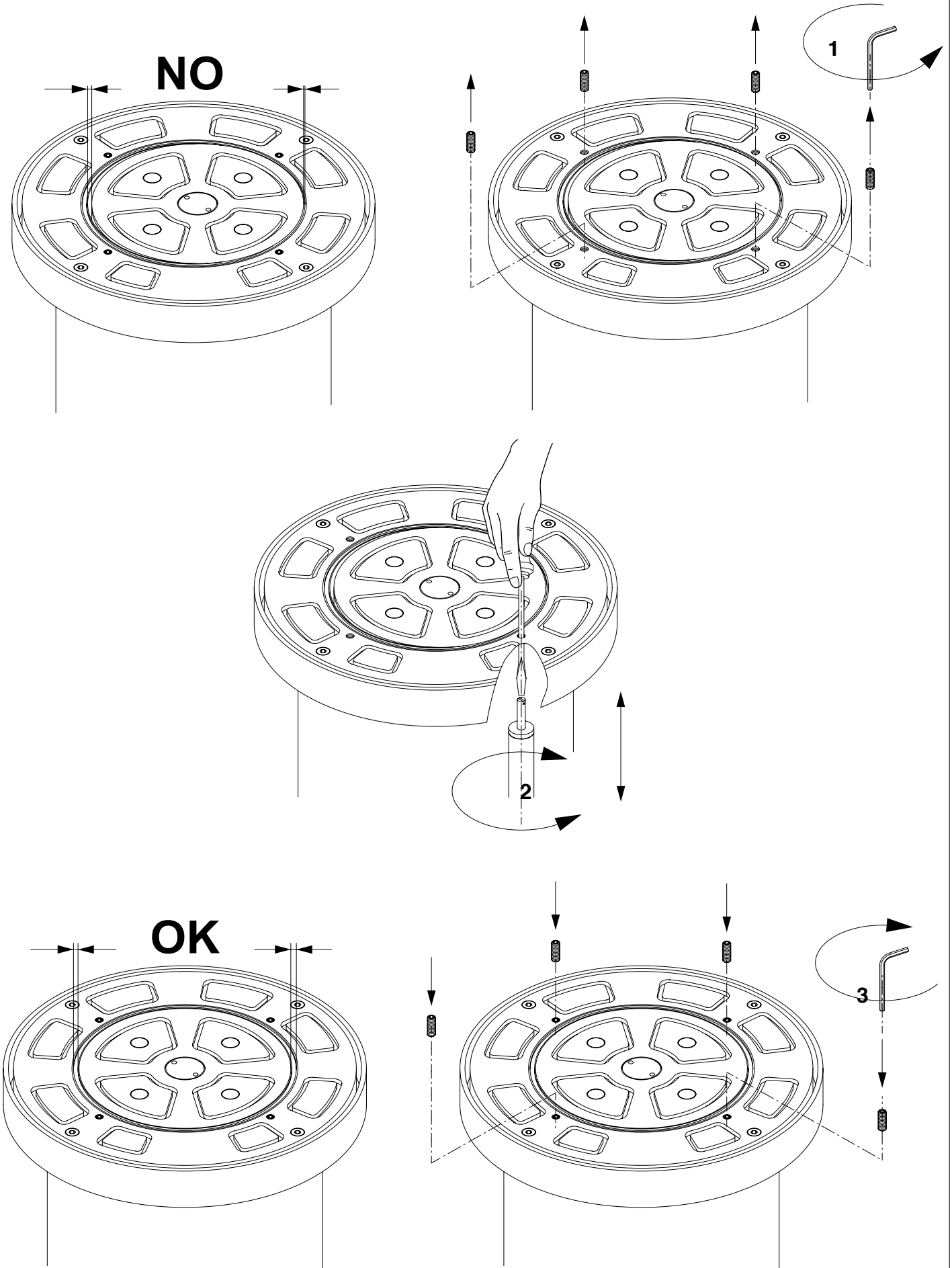


Fig. 6

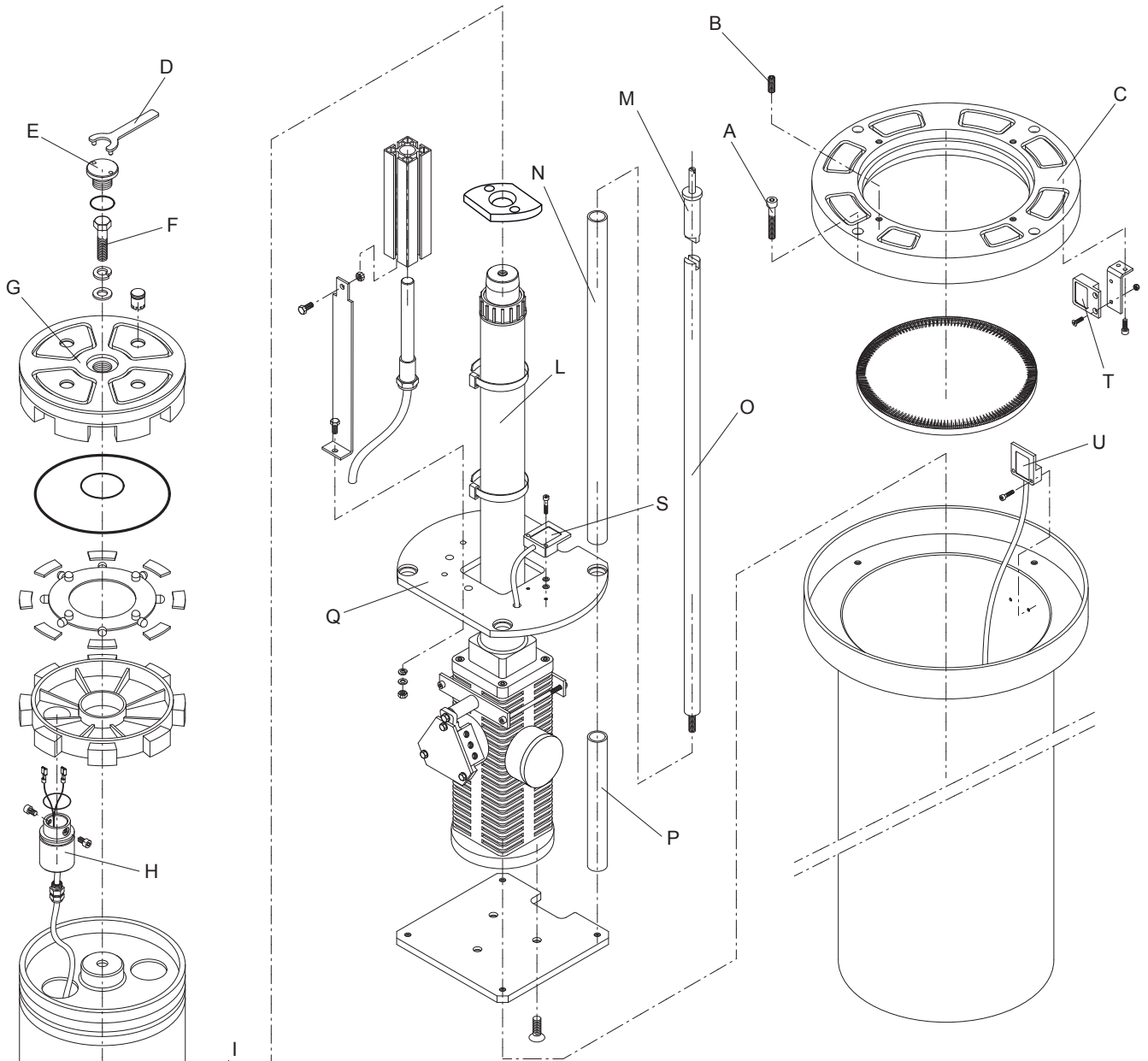


Fig. 7


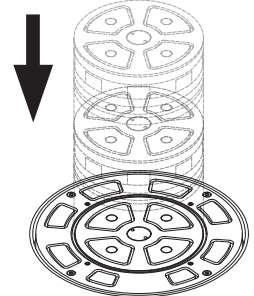
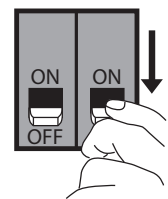
 **WARNING:** Remove the protective rubber ring before use.

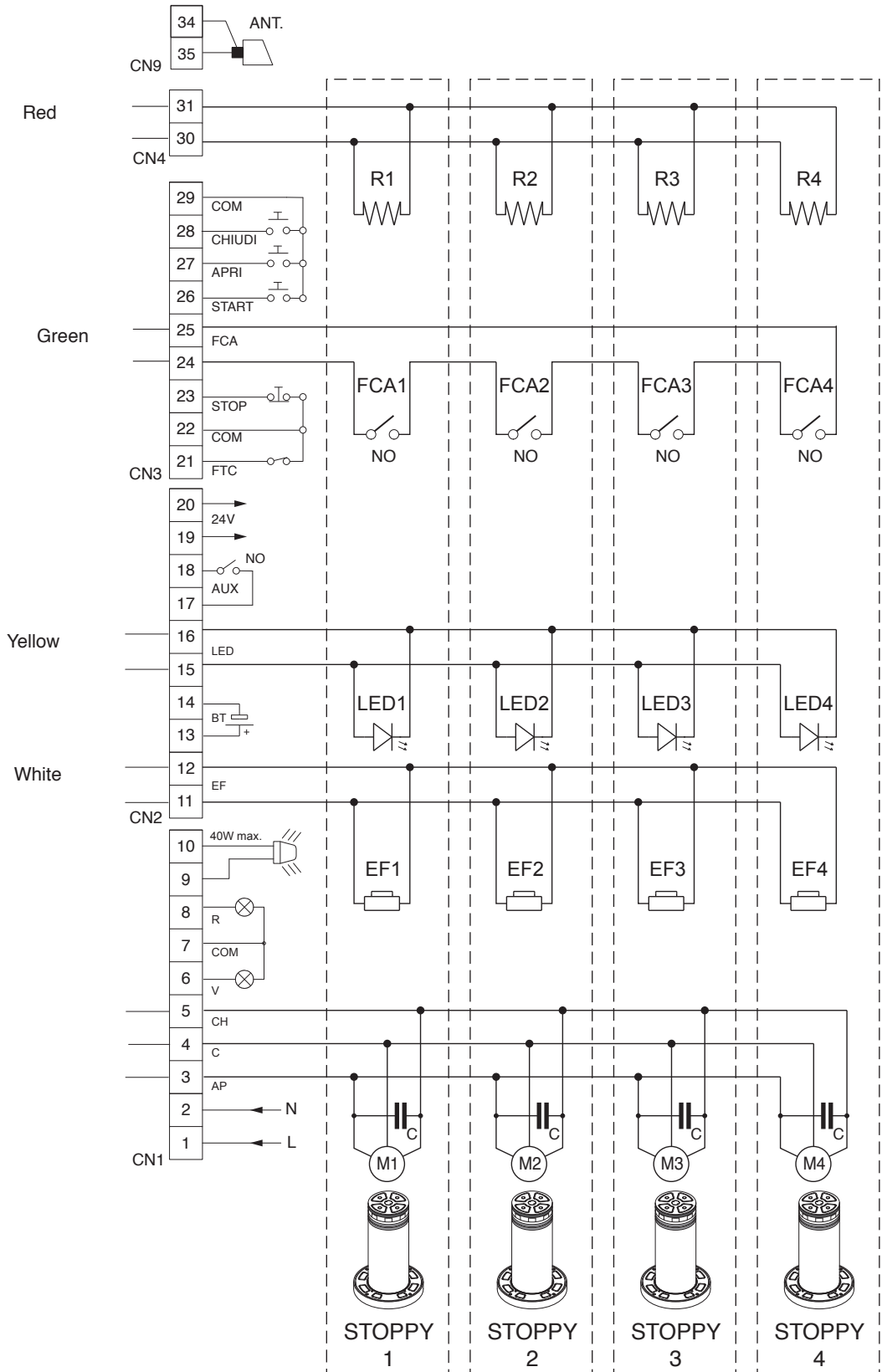


Fig. 8



WARNING: Correct concentric adjustment.

Fig. 9



Brown
Blue
Black

BFT S.P.A.
Via Lago di Vico 44, 36015 Schio (VI) - **Italy**
tel. +39 0445 69 65 11 / fax. +39 0445 69 65 22
www.bft.it / e-mail: info@bft.it

AUTOMATISMES BFT FRANCE
13 BdL E. Michelet, 69008 Lyon - **France**
tel. +33 (0)4 78 76 09 88 - fax +33 (0)4 78 76 92 23
e-mail: contacts@automatismes-bft-france.fr



BFT Torantriebssysteme GmbH
Faber-Castell-Straße 29
D - 90522 Oberasbach - **Germany**
tel. +49 (0)911 766 00 90 - fax +49 (0)911 766 00 99
e-mail: service@bft-torantriebe.de

BFT Automation UK Ltd
Unit 8E, Newby Road
Industrial Estate Hazel Grove, Stockport,
Cheshire, SK7 5DA - **UK**
tel. +44 (0) 161 4560456 - fax +44 (0) 161 4569090
e-mail: info@bftautomation.co.uk

BFT BENELUX SA
Parc Industriel 1, Rue du commerce 12
1400 Nivelles - **Belgium**
tel. +32 (0)67 55 02 00 - fax +32 (0)67 55 02 01
e-mail: info@bftbenelux.be

BFT-ADRIA d.o.o.
Obrovac 39
51218 Dražice (Rijeka)
Hrvatska - **Croatia**
tel. +385 (0)51 502 640 - fax +385 (0)51 502 644
e-mail: info@bft.hr

BFT Polska Sp. z o.o.
ul. Kołacińska 35
03-171 Warszawa - **Poland**
tel. +48 22 814 12 22 - fax +48 22 814 39 18
e-mail: biuro@bft.com.pl

BFT USA BFT U.S., Inc.
6100 Broken Sound Pkwy. N.W., Suite 14
Boca Raton, FL 33487 - **U.S.A.**
T: +1 561.995.8155 - F: +1 561.995.8160
TOLL FREE 1.877.995.8155 - info.bft@bft-usa.com

BFT GROUP ITALIBERICA DE AUTOMATISMOS S.L.
Poi. Palou Nord,
Sector F - C/Cami - Can Basa nº 6-8 08401 Granollers -
(Barcelona) - Spain
tel. +34 938 61 48 28 - fax +34 938 70 03 94
e-mail: bftbcn@bftautomatismos.com

Pi. Comendador - C/
informática, Nave 22 - 19200 Azuqueca de henares
(Guadalajara) - Spain
tel. +34 949 26 32 00 - fax +34 949 26 24 51
e-mail: administracion@bftautomatismos.com

BFT SA-COMERCIO DE AUTOMATISMOS E MATERIAL DE SEGURANÇA
Urbanizaçao da Pedrulha Lote 9 - Apartado 8123,
3020-305 COIMBRA - **PORTUGAL**
tel. +351 239 082 790 - fax +351 239 082 799
e-mail: geral@bftportugal.com