User Manual for the

SM300

Soil Moisture Sensor



SM300-UM-1.1



Delta-T Devices Ltd

Notices

Copyright

All parts of the SM300 design and documentation are the exclusive right of Delta-T Devices and covered under copyright law.
© 2010 Delta-T Devices Ltd. Patent(s) pending.

EMC Compliance

See page 29.

Design changes

Delta-T Devices Ltd reserves the right to change the designs and specifications of its products at any time without prior notice.

User Manual Version:

SM300-UM-1.1 Juneay 2010



Delta-T Devices Ltd
130 Low Road,
Burwell
Cambridge CB25 0E,
UK

Tel: +44 1638 742922
Fax: +44 1638 743155
email: sales@delta-t.co.uk
web: www.delta-t.co.uk

Contents

Introduction	5
Description	5
Features	5
Dimensions	6
Parts list	7
Care and Safety	8
How the SM300 works	9
Operation	10
Cable Connections	10
Installation	11
Logger connections and configuration	12
GP1	12
DL6	13
DL2e	14
Other data loggers	15
HH2 Meter	16
Calibration	17
Soil calibration	18
Sensor calibration	20
Soil moisture reading	21
Troubleshooting	23
Technical Reference	25
Specifications	25
Volumetric water content	25
Temperature	25

<i>SM300 must be fully buried to accurately measure soil temperature</i>	25
Definitions	30
References	32
Technical Support	33
Appendix 1	35
Soil-specific Calibration	35
Laboratory calibration for non-clay soils	36
Laboratory calibration for clay soils	39
Appendix 2:	42
The SM300 Temperature Sensor	42
SM300 Temperature Measurement	43
Effect of Temperature on Water Permittivity	44
Resistance to Temperature Lookup Table	45
Index	46

Introduction

Description

The *SM300* measures soil moisture content and temperature. Its sealed plastic body is attached to two sensing rods which insert directly into the soil for taking readings.

A waterproof plug connects to a choice of signal cables. Both extension cables and extension tubes can be used.

The soil moisture output signal is a differential analogue DC voltage. This is converted to soil moisture by a data logger or meter using the supplied general soil calibrations. It can also be calibrated for specific soils.

Features

- Soil moisture accurate to $\pm 2.5\%$
- Soil temperature to $\pm 0.5^{\circ}\text{C}$ over $0\text{-}40^{\circ}\text{C}$
- Low salinity sensitivity
- Excellent stability
- Minimal soil disturbance
- Easy installation at depth in augered holes
- Waterproof connector to IP68
- Rugged, weatherproof and can be buried.
- Good electrical immunity
- Choice of cabling system options
- Cable connector, cylindrical profile and extension tube design simplifies removal for servicing.



See also ***Specifications*** on page 25

Dimensions





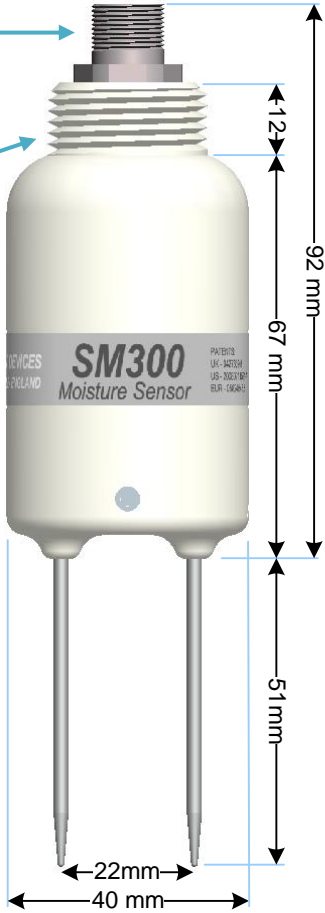

Cable connector sealed to IP68
M12, 5 pin, male

Thread 3/4inch BSP
for connecting to
Extension Tube(s)

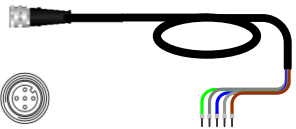

Parts list

Your shipment may include the following:

Part	Sales Code	Description
	SM300	SM300 sensor with Quick Start Guide
	SMSC/d-HH2	1.5m cable connects to HH2 meter via 25-way D-connector
	SMSC/sw-05	5m cable with 100 mm flying leads for GP1 or DL6 logger
	SMSC/lw-05	5m cable with 200mm flying leads for DL2e logger
	EXT/5W-05 EXT/5W-10 EXT/5W-25	5, 10 and 25m extension cables. IP68 M12 connectors
	ML/EX50 ML/EX100	50 and 100cm Extension Tube
	SM-AUG-100	45mm spiral auger 1.2m long

Care and Safety

- The rods of the SM300 are sharp in order to ease insertion. Care must be taken and handling precautions followed.
- Avoid touching the rods or exposing them to other sources of static damage, particularly when powered up. Keep the SM300 in its protective tube when not in use.
- Take care when attaching cables to ensure that the connectors are clean, undamaged and properly aligned *before* pushing the parts together.
- Do not pull the SM300 out of the soil by its cable.
- If you feel strong resistance when inserting the SM300 into soil, it is likely you have encountered a stone. Stop pushing and re-insert at a new location.
- Do not touch the pins, particularly when the sensor is attached to a cable. An electrostatic discharge from your body can typically cause a temporary -10mV offset in sensor readings for up to one hour. At worse it may permanently damage the sensor.

To prevent personal injury and damage to the probe always store and transport the SM300 in this protective tube

CAUTION
SHARP PINS



How the SM300 works

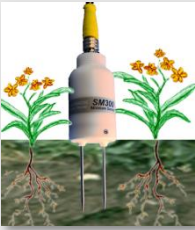

When power is applied to the SM300...

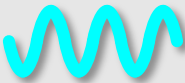

...it creates a 100MHz waveform (similar to FM radio).



The waveform is applied to a pair of stainless steel rods which transmit an electromagnetic field into the soil.

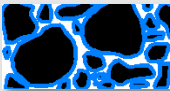

The water content of the soil surrounding the rods...

ϵ

...dominates its **permittivity**.

(A measure of a material's response to polarisation in an electromagnetic field. Water has a permittivity ≈ 81 , compared to soil ≈ 4 and air ≈ 1)

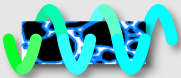

The permittivity of the soil has a strong influence on the applied field...

V_{out}



...which is detected by the SM300, resulting in a stable voltage output that...

Soil Moisture
22 %

...acts as a simple, sensitive measure of **soil moisture content**.

Operation

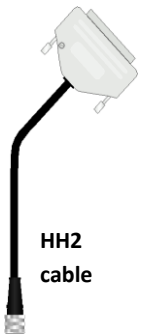
Cable Connections

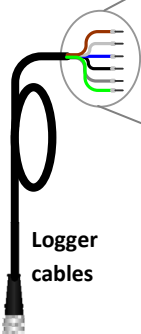
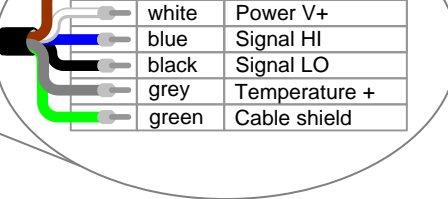
 <p>HH2 cable</p>	 <p>Extension cables</p>	 <p>Logger cables</p>	 <table border="1"> <tr> <td>brown</td> <td>Power 0V</td> </tr> <tr> <td>white</td> <td>Power V+</td> </tr> <tr> <td>blue</td> <td>Signal HI</td> </tr> <tr> <td>black</td> <td>Signal LO</td> </tr> <tr> <td>grey</td> <td>Temperature +</td> </tr> <tr> <td>green</td> <td>Cable shield</td> </tr> </table>	brown	Power 0V	white	Power V+	blue	Signal HI	black	Signal LO	grey	Temperature +	green	Cable shield
brown	Power 0V														
white	Power V+														
blue	Signal HI														
black	Signal LO														
grey	Temperature +														
green	Cable shield														
<p>1.5m</p>	<p>5m 10m 25m</p>	<p>5m with 100 or 200 mm bare leads</p>													

- Take care when attaching cables to ensure that the connectors are clean, undamaged and properly aligned **before** pushing the parts together.
- Screw together firmly to ensure the connection is water-tight.
- Extension cables can be joined up to a recommended maximum of 100m – see Specifications on page 25

Installation

Surface installation and spot measurements

- Clear away any stones. Pre-form holes in very hard soils before insertion.
- Push the SM300 into the soil until the rods are fully inserted. Ensure good soil contact.
- If you feel strong resistance when inserting the SM300, you have probably hit a stone. Stop, and re-insert at a new location.

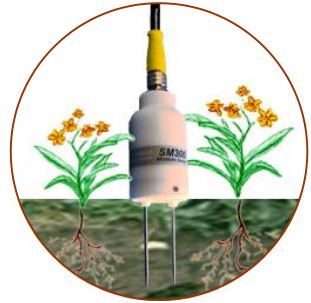

Note: The SM300 is not suitable for soil surface temperature measurements. For soil temperature near the surface dig a trench and install horizontally as shown below. Cover both SM300 and the first 30cm of cable with at least 5cm of soil.

Installing at depth

- Make a 45mm diameter hole, preferably at about 10° to the vertical using the **SM-AUG-100** auger.
- Connect an extension tube e.g. **ML/EX50**
- Push the SM300 into the soil until rods are fully inserted. Ensure good soil contact.

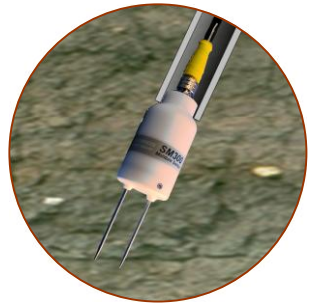

Alternatively

- Dig a trench, and install horizontally.

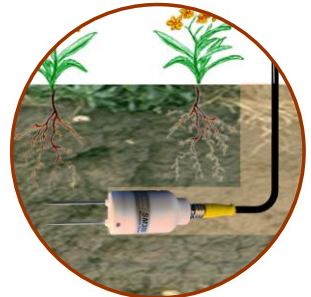

Logger connections and configuration

GP1

Two SM300s can connect to each GP1. Each soil moisture sensor is wired as a differential, powered sensor.

These details illustrate connection to Channels 1 and 3:



<i>SM300 wiring</i>	<i>Colour</i>	<i>GP1 terminal</i>
Power 0V	brown	CH1 (GND) or Temp (GND)
Power V+	white	CH1 (PWR)
Signal HI	blue	CH1 (+)
Signal LO	black	CH1 (-)
Temperature +	grey	Temp3 (IN)
Cable shield	green	CH1 (GND)

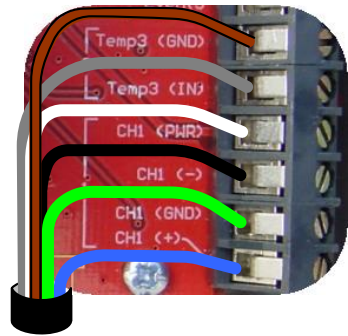

Using the DeltaLINK¹ logger software, configure channel 1 or 2 as sensor type **SM300** and channel 3 or 4 as an **SM300 Temperature** sensor.

See also **GP1 Quick Start Guide** and the DeltaLINK on-line Help.

¹ You need the PC logger software DeltaLINK version 2.4 or later. A free upgrade can be obtained from www.delta-t.co.uk or from the **Software and Manuals CD** Issue 3.

DL6

6 SM300s can be connected to a DL6. Each soil moisture sensor is wired as a differential, powered sensor. A DL6 logger can only read one SM300 temperature sensor.*



These details illustrate connection to channels 6 & 7:

<i>SM300 wiring</i>	<i>Colour</i>	<i>DL6 terminal</i>
Power 0V	brown	0V
Power V+	white	V+
Signal HI	blue	IN+
Signal LO	black	IN-
Temperature +	grey	RES IN+
Cable shield	green	<i>///</i>

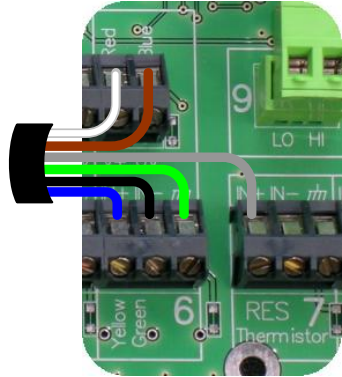

In DeltaLINK² configure channel 6 as type **SM300** and channel 7 as a type **SM300 Temperature** sensor.

See also the **DL6 Quick Start Guide** and the DeltaLINK online Help.

² You need the PC logger software DeltaLINK version 2.4 or later. A free upgrade can be obtained from www.delta-t.co.uk or from the **Software and manuals CD** Issue 3.

DL2e

Up to 60 SM300s can be connected to a DL2e logger (if not using the temperature sensor channel).

Up to 30 SM300s can be connected if also reading the temperature sensor.

Each moisture sensor is connected as a differential, powered sensor.



These details illustrate connection to Channels 57 and 58 using a LAC1 input card configured in 15-channel mode, and warm-up channel 63:

<i>SM300 wiring</i>	<i>Colour</i>	<i>DL2e terminal</i>
Power 0V	brown	CH62- or 61-
Power V+	white	CH63 NO
Signal HI	blue	CH58+
Signal LO	black	CH58-
Temperature +	grey	CH57+ and CH57-
Cable shield	green	CH61- or 62-

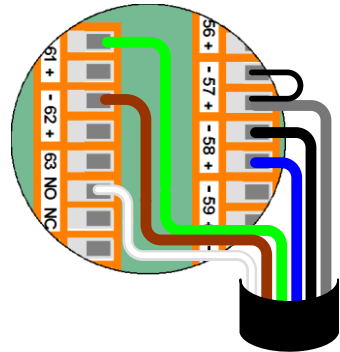

Configure the chosen DL2e logger channels by selecting the appropriate **S3M and S3O** sensor types for mineral and organic soils and **S3T** for the temperature sensor type listed in the Ls2Win³ sensor library.

See the **DL2e User Manual** and the Ls2Win online help

³ You need a PC running Ls2Win version 1.0 SR6 or later. A free upgrade can be obtained from www.delta-t.co.uk or from the **Software and manuals CD** Issue 3.

Other data loggers

- The SM300 soil moisture output should be connected as a differential, powered sensor.
- Configure the logger to convert the SM300 readings from milliVolts into soil moisture units by using either :-
Polynomial conversion on page 21 or
Linearisation table conversion on page 22

Note: Output signals in the range 0 to 1.0 volts from the SM300, corresponding to ~0 to 60% water content in mineral soils – see **Linearisation table conversion** on page 22.

Note: The SM300 has been optimised for warm-up of 0.5 to 1 second duration.

It is recommended that the sensor is not powered continuously.

- The temperature sensor output should be read as a resistance and the logger configured with a look-up table to convert the measured resistance to temperature.

See **SM300 Temperature Measurement** on page 43
and **Resistance to Temperature Lookup Table** on page 45.

HH2 Meter

This assumes you have version 2.5 or later for both the PC software HH2Read and the HH2 firmware (see foot of page).



- Connect the SM300 to the HH2 meter.
- Press **Esc** to turn the meter on, and if necessary press again until the HH2 displays the start-up screen.

- Set the meter to read from an SM300:

- ▶ Press **Set** and scroll down to the **Device** option.
- ▶ Press **Set** again and scroll down to select SM300.
- ▶ Press **Set** to confirm this choice.

Device: **SM300**

- Make sure the HH2 is correctly configured for your soil type:

- ▶ At the start-up screen, press **Set** and scroll down to the **Soil Type** option.
- ▶ Press **Set** again and scroll down to the appropriate soil type (use **Mineral** for sand, silt or clay soils or **Organic** for peaty soils)
- ▶ Press **Set** to confirm this choice.

Soil Type:
Mineral

- Choose the units you want for displaying readings.

- ▶ At the start-up screen, press **Set** and scroll down to the **Display** option.
- ▶ Press **Set** again and scroll down to select units.
- ▶ Press **Set** to confirm this choice.

- Press **Read** to take a reading.

- Press **Store** to save or **Esc** to discard the reading.

SM300 Store?
20.3%vol

- Remove the SM300 from the soil and move to a new location...

- If you have saved data, connect your HH2 to a PC and run **HH2Read** to retrieve the readings.



See also: **Support for the SM300 Soil Moisture Sensor with an HH2** and **HH2 User Manual** and **HH2 User Manual Addendum to V4 - SM300**.

Note: the HH2 does not display or store SM300 temperature readings.

Note: For an upgrade contact Delta-T.

Calibration

The SM300 is provided with general calibrations for **mineral** and **organic** soils which can be used to convert the output from the sensor directly into soil moisture when used with Delta-T loggers and the HH2 moisture meter. This section explains how these calibrations work, how to adapt them for other soils and how to provide calibrations for other data loggers.

The SM300 measures volumetric soil moisture θ , by detecting the dielectric properties of the damp soil – the permittivity, ϵ , or more conveniently the **refractive index**, which is closely equivalent to $\sqrt{\epsilon}$. The SM300 response is best understood in these stages:

1. Soil calibration

$\theta \rightarrow \sqrt{\epsilon}$

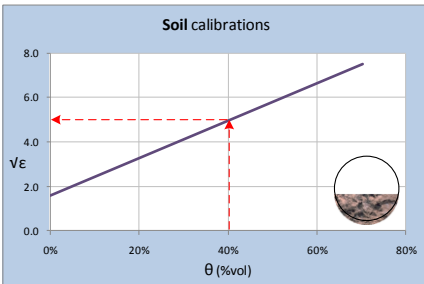

2. Sensor calibration

$V \rightarrow \sqrt{\epsilon}$

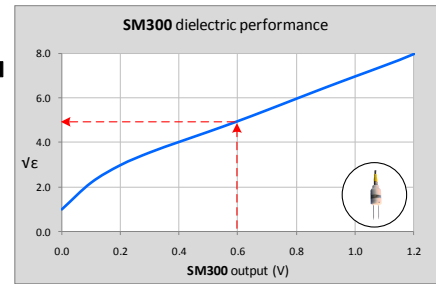

3. Soil moisture reading

$V \rightarrow \theta$

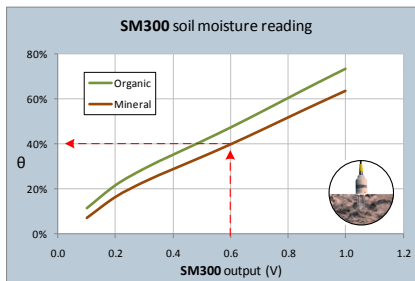

Soil calibration

Damp soil is essentially a mixture of soil particles, air and water, and together these components determine its dielectric properties, including the refractive index $\sqrt{\epsilon}$. The refractive index of the mixture is approximated simply by adding the contributions from the individual components [ref 4.].

For a particular soil, the contribution from the soil particles can be assumed to be constant, so the refractive index measured by the SM300 is only affected by changes to the water content, θ . This relationship simplifies to:

$$\sqrt{\epsilon} = a_0 + a_1 \cdot \theta$$

where the coefficients a_0 and a_1 conveniently parameterise the dielectric properties of soils.

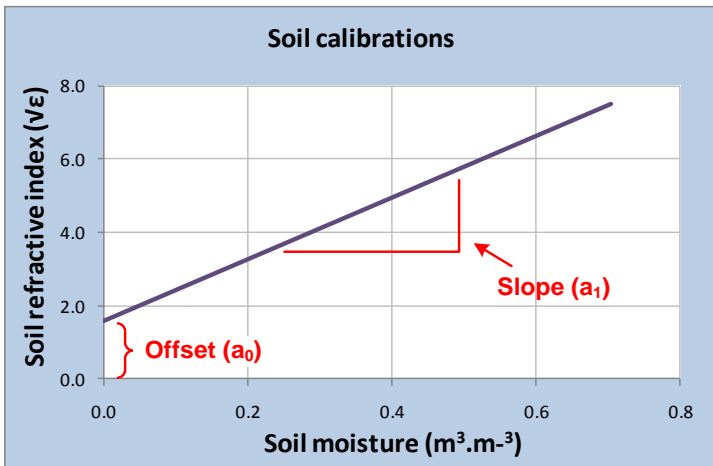

Note that:

$a_0 = \sqrt{\epsilon_{dry_soil}}$ is usually between 1.3 to 2.3

a_1 corresponds approximately to $\sqrt{\epsilon_{water}} - 1$ and usually takes a value about 8.0. Real soil values for a_0 and a_1 can vary significantly from these guidelines when they are affected by other factors – in particular, bound water in clay may result in higher values of a_1 .

General soil calibrations

Most soils can be characterised simply by choosing one of the two general calibrations we supply, one for mineral soils (predominantly sand, silt and clay) and one for organic soils (with a high organic matter content).

	a_0	a_1
Mineral soils	1.6	8.4
Organic soils	1.3	7.7

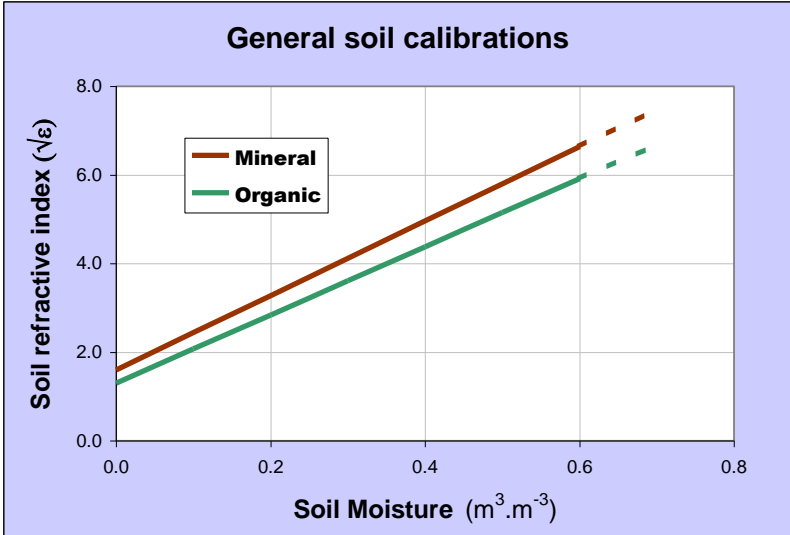

These values have been used to generate the polynomial conversions and linearisation tables in the **Soil moisture reading** section.

Soil-specific calibration

Instead of adopting these general calibrations, you may wish to determine specific calibration values of a_0 and a_1 for your soil. This procedure is fairly straightforward if you can get access to standard laboratory equipment and is described in detail in Appendix 1 on page 34.

Soil specific calibration can significantly improve the accuracy of individual readings - but make less of an improvement to readings where installation and sampling errors are high.

Sensor calibration

Each SM300 is individually adjusted to provide consistent dielectric performance:

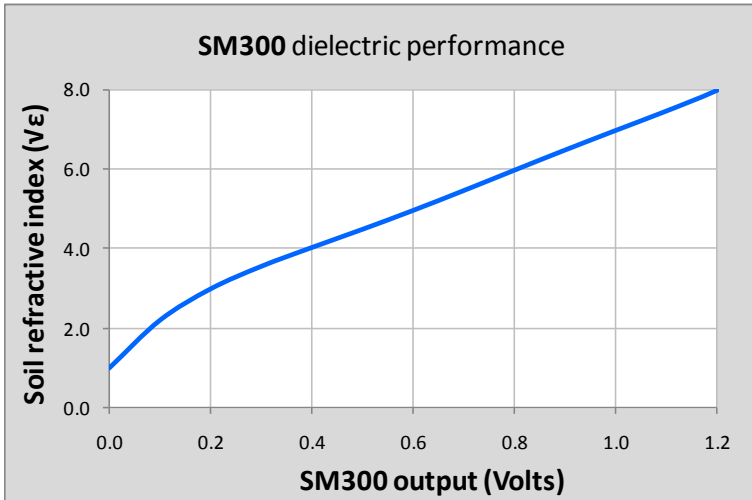

This response can be approximated either by a polynomial (below) or by a linearisation table (see next page):

Polynomial (for use over the full range of SM300 readings)

$$\sqrt{\epsilon} = 1.0 + 14.868V - 33.56V^2 + 51.223V^3 - 36.283V^4 + 9.715V^5$$

where V is the SM300 output in Volts

Linearisation table

(for use over the full range of SM300 readings)

V	$\sqrt{\epsilon}$	V	$\sqrt{\epsilon}$	V	$\sqrt{\epsilon}$	V	$\sqrt{\epsilon}$	V	$\sqrt{\epsilon}$
0.000	1.000	0.300	3.556	0.600	4.956	0.900	6.471	1.200	7.961
0.075	1.963	0.375	3.913	0.675	5.327	0.975	6.841	1.275	8.411
0.150	2.641	0.450	4.254	0.750	5.708	1.050	7.205	1.350	8.971
0.225	3.149	0.525	4.598	0.825	6.092	1.125	7.571	1.425	9.724

Soil moisture reading

Polynomial conversion

Combining the **Soil calibrations** and **Sensor calibration** steps, the conversion equation becomes:

$$\theta = \frac{[1.0 + 14.868V - 33.56V^2 + 51.223V^3 - 36.283V^4 + 9.715V^5] - a_0}{a_1}$$

where a_0 and a_1 are the calibration coefficients.

For a generalised **mineral** soil this becomes:

$$\theta_{\text{mineral}} = -0.071 + 1.77V - 3.995V^2 + 6.098V^3 - 4.319V^4 + 1.157V^5$$

And for a generalised **organic** soil:

$$\theta_{\text{organic}} = -0.039 + 1.931V - 4.358V^2 + 6.652V^3 - 4.712V^4 + 1.262V^5$$

Linearisation table conversion

The conversion from SM300 reading (Volts) to soil moisture θ ($\text{m}^3 \cdot \text{m}^{-3}$ or %vol) can be accomplished by a look-up table.

The following table lists the values used for the DL2e data logger:

Soil moisture %vol	Mineral soil Volts	Organic soil Volts	Soil moisture %vol	Mineral soil Volts	Organic soil Volts
-4	-2.090	-2.090	52	0.801	0.670
0	0.044	0.021	56	0.867	0.731
4	0.074	0.045	60	0.934	0.791
8	0.108	0.072	64	1.003	0.852
12	0.147	0.102	68	1.072	0.913
16	0.193	0.137	72	1.140	0.976
20	0.248	0.178	76	1.204	1.039
24	0.313	0.226	80	1.260	1.102
28	0.384	0.281	84	1.309	1.163
32	0.457	0.343	88	1.351	1.220
36	0.530	0.410	92	1.388	1.270
40	0.600	0.477	96	1.419	1.314
44	0.669	0.544	100	1.447	1.352
48	0.735	0.608	104	2.090	2.090

Troubleshooting

Always try to identify which part of the measurement system is the source of the difficulty. For the *SM300* this may fall into one of the following areas:

The measurement device

What equipment is being used to read the probe output?

- A Delta-T HH2 Moisture Meter.
Note: the HH2 does not measure SM300 temperature.
- A Delta-T data logger such as the GP1, DL6 or DL2e

Check Versions

Check you have the correct versions:

HH2 Meter: Firmware version 2.5 and PC software HH2read version 5 or later are recommended.

GP1 & DL6 Loggers: DeltaLINK version 2.4 or later is required.

DL2e Logger: Ls2Win 1.0 SR6 is required

Consult the user manuals or the on-line help for these devices and their related software.

Try alternative types of equipment if you have them available.

Check that you are using an appropriate soil calibration and the correct conversion method – see **Calibration** section.

The SM300 itself

Try to isolate the problem into one of the following areas

- The SM300 or the connecting cable

Then try to narrow down the area further

- Mechanical problems faults, or damage
- Electrical or electronic problems or faults

Functional check

The following two simple checks can be used to establish whether your SM300 is functioning within expected bounds:

Air reading

Hold the SM300 away from other objects and take a reading using an HH2 meter, or voltmeter or logger.

The reading should be $0 \pm 4\text{mV}$ when used with a 5m cable.

Warning : Do not touch the pins

Do not touch the pins when the sensor is attached to a cable. A typical electrostatic discharge from your body can create a temporary -10mV offset in sensor readings lasting for up to one hour.



Mid range reading – dip rod tips in water

If you wish to take a quick reading to check the sensor is working you can dip the sensor into water.

With the pins half-immersed in tap water an HH2 set to read an SM300 with soil type set to Organic should give a reading in the range 80 to 100%vol.

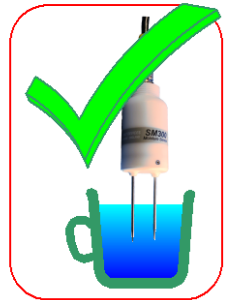

Technical Reference

Specifications

Volumetric water content	
Accuracy	±2.5% vol over 0 to 50% vol and 0-60°C
Measurement range	0 to 100% vol with reduced accuracy ⁴
Salinity error (see p.26)	≤3.5%vol over 50 to 1000 mS.m ⁻¹ and 0-40% vol
Output Signal	0-1V differential ≈ 0 to 60% vol nominal
Output compatible with	GP1, DL6, DL2e, HH2
Temperature	<i>SM300 must be fully buried to accurately measure soil temperature</i>
Sensor accuracy	±0.5°C over 0-40°C <i>not including logger or cabling error</i>
Output	Resistance ⁵ : 5.8kΩ to 28kΩ
Output compatible with	GP1, DL6 ⁶ , DL2e
Cabling error contribution (to temperature readings)	Negligible for GP1 & DL6 (any cable length) Negligible for DL2e (with 5m cable) ⁷
Maximum cable length	100m (GP1 & DL6 data loggers) 100m (DL2e: water content measurement) 25m (DL2e: temperature measurement)
Power requirement	5-14VDC, 18mA for 0.5 to 1s
Operating range	-20 to +60°C
Environment	IP68
Sample volume	55 x 70mm diameter
Dimensions	143 x 40 mm diameter
Weight	77 gm (without cable)

4 In water (no soil present) the reading may not be 100% vol. It depends on a0 and a1 but can still be used as a quick check that the unit is working. See page 24.

5 See Appendix 2 on page 42.

6 Note: The DL6 has only one temperature channel. The DL6 error contribution to SM300 temperature measurement is negligible compared to the accuracy of the SM300 temperature sensor itself. The two only become comparable below -15C.

7 DL2e logger users can apply a correction in the Ls2Win logging software (for cable lengths >5m)

Conductivity response

This chart shows how salinity affects the output of the soil moisture sensor at various soil moisture levels.

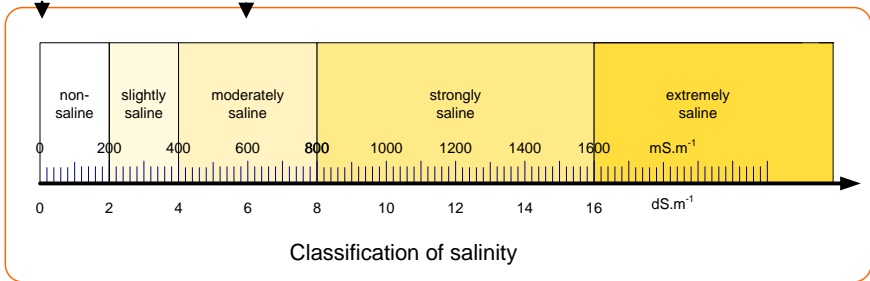
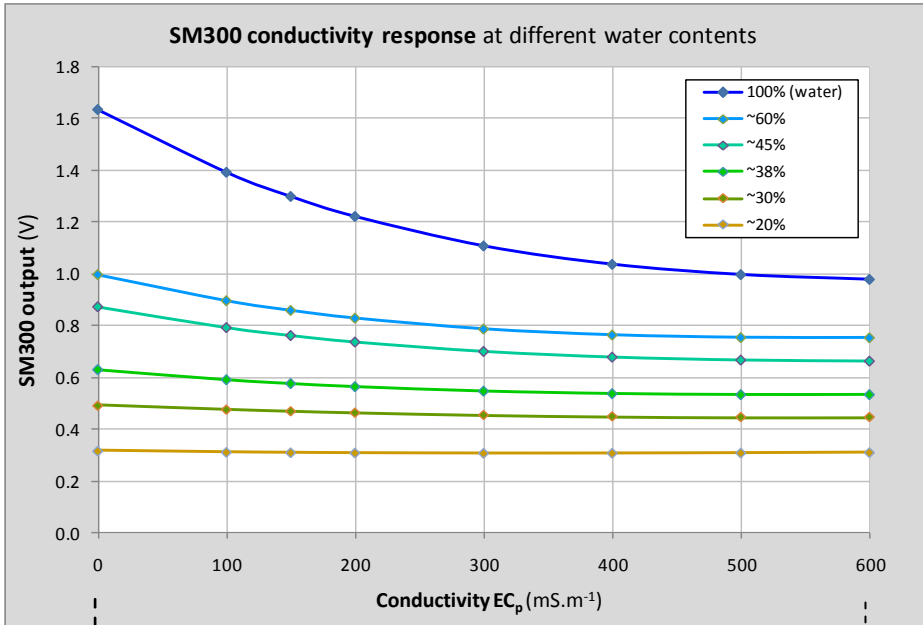

Temperature response of soil moisture readings

The effect of temperature on the SM300 soil moisture readings in any particular soil will depend on a combination of effects:

- The SM300 soil moisture electronics has very low temperature sensitivity, and makes a negligible contribution to the overall sensitivity.
- The refractive index of water ($\sqrt{\epsilon}$, see **Calibration** section) reduces as the temperature increases. This produces a negative temperature response particularly in soils or substrates with high water content.
- Water that is bound to the surface of soil particles has a much lower refractive index than free water. The percentage of bound water decreases with temperature and this produces a positive temperature response particularly in clay soils at lower water contents.

The last two effects partially offset each other, but in soil conditions where one or the other effect dominates, the SM300 will appear to have a significant temperature response. This illustration is based on the model in reference 7, see page 32.

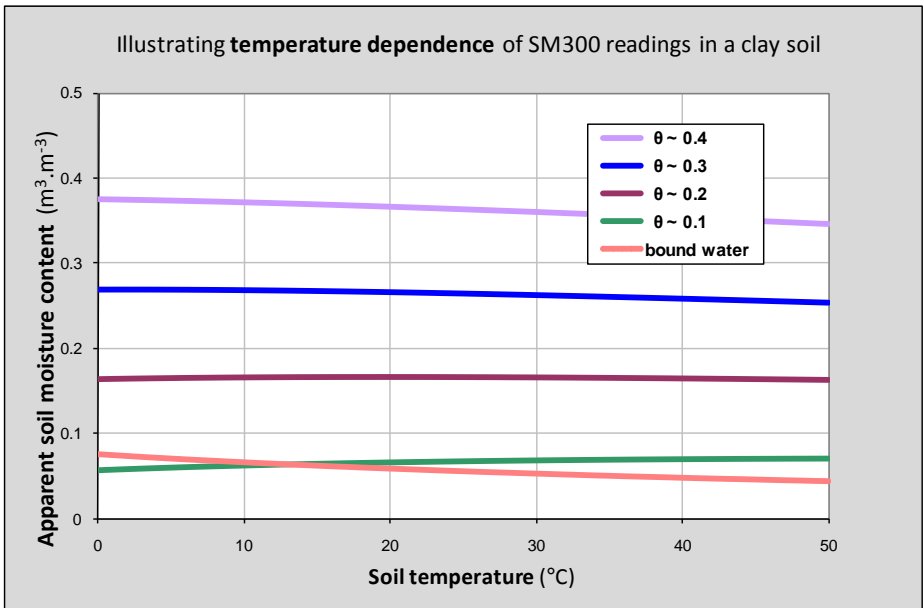

Note: ice has a quite different refractive index from water, so SM300 soil moisture readings cannot be interpreted reliably when inserted into soil below 0°C.

Sampling Volume

The SM300 is most sensitive to signals very close to the two rods, but a small proportion of the signal reaches up to 50mm from the rods.

Minimum soil sample size: Full accuracy requires a soil volume of one litre but the additional error from taking a reading in a 0.5 litre sample is negligible

SM300s may interact if they are placed too close together – they should be separated by at least 100mm.

If the SM300 is inserted too close to the wall of a plant pot the sensing field can “see” outside the pot. This behaviour is shown in the graph below.

For best results keep a gap of at least 25mm (1 inch) between the body of the sensor and the wall of the plant pot.

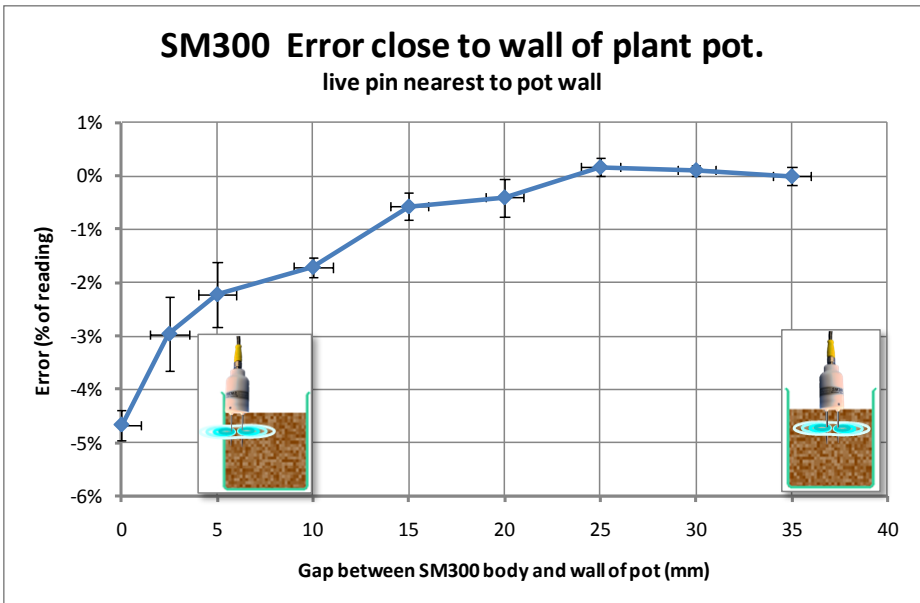

Electromagnetic Compatibility (EMC)

General information

SM300 is a Class A product, intended for operation in non-residential environments.

Only use cables and accessories authorised by Delta-T (sensor cables from other sources for example may adversely affect product performance and affect quality of results).

If possible route cables along the soil surface or bury them – this also reduces possible trip hazard and animal damage.

Do not modify the product or its supplied accessories.

See also **SM300 EMC Guidance** on the Software and Manuals CD Issue 3.

Regulatory information

Europe

This device conforms to the essential requirements of the EMC directive 2004/108/EC, based on the following test standards:

EN61326-1:2006 Electrical requirement for measurement, control and laboratory use. EMC requirements: Group 1, Class A equipment – (emissions section only).

EN61326-1:2006 Electrical requirement for measurement, control and laboratory use. EMC requirements: Basic Immunity (immunity section only).

FCC compliance (USA)

This device conforms to Part 18 of FCC rules – Industrial, Scientific & Medical Equipment.

Note: with reference to FCC Part 18.115 Elimination and investigation of harmful interference.

(a) The operator of the ISM equipment that causes harmful interference to radio services shall promptly take appropriate measures to correct the problem.

Definitions

Volumetric Soil Moisture Content is defined as

$$\theta_v = \frac{V_w}{V_s} \quad \text{where } V_w \text{ is the volume of water contained in the sample}$$

and V_s is the total volume of the soil sample.

The preferred units for this ratio are $\text{m}^3 \cdot \text{m}^{-3}$, though %vol is frequently used.

Soil Moisture Content varies from approx. $0.02 \text{ m}^3 \cdot \text{m}^{-3}$ for sandy soils at the permanent wilting point, through approx. $0.4 \text{ m}^3 \cdot \text{m}^{-3}$ for clay soils at their field capacity, up to values as high as $0.85 \text{ m}^3 \cdot \text{m}^{-3}$ in saturated peat soils.

Gravimetric Soil Moisture Content is defined as

$$\theta_G = \frac{M_w}{M_s} \text{ g.g} \quad \text{where } M_w \text{ is the mass of water in the sample, and } M_s \text{ is the total mass of the dry sample.}$$

To convert from volumetric to gravimetric water content, use the equation

$$\theta_G = \theta_v \times \frac{\rho_w}{\rho_s} \quad \text{where } \rho_w \text{ is the density of water } (= 1 \text{ g.cm}^{-3}), \text{ and } \rho_s \text{ is the bulk density of the sample } \left(\frac{M_s}{V_s} \right).$$

Organic and Mineral soil definitions:

The general calibrations have been optimised to cover a wide range of soil types, based on the following definitions:

Soil type	optimised around organic content:	use for organic contents:	bulk density range: (g.cm ⁻³)	use for bulk densities: (g.cm ⁻³)
Mineral	~ 1 %C*	< 7 %C	1.25 - 1.5	> 1.0
Organic	~ 40 %C	> 7 %C	0.2 - 0.7	< 1.0

* Note: %C denotes "percentage Carbon" and is a measure of organic content

Salinity

The preferred SI units for ionic conductivity are **mS.m⁻¹** (where S is Siemens, the unit of electric conductance = ohm⁻¹).

The following conversions apply:

$$\begin{aligned}
 1 \text{ mS.m}^{-1} &= 0.01 \text{ dS.m}^{-1} \\
 &= 0.01 \text{ mS.cm}^{-1} \\
 &= 10 \text{ } \mu\text{S.cm}^{-1}
 \end{aligned}$$

Soil salinity can be classified using the following descriptive categories:

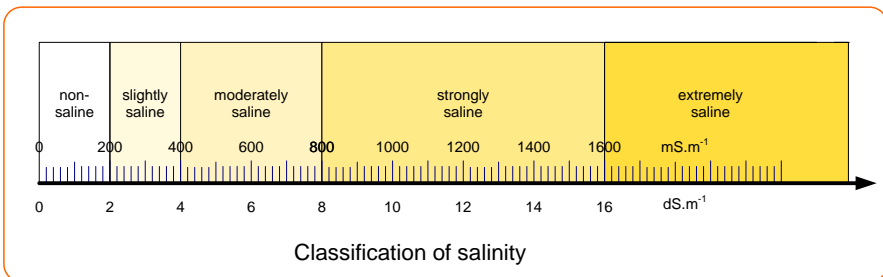

See also http://www.land.vic.gov.au/DPI/Vro/vrosite.nsf/pages/water_spotting_soil_salting_class_ranges#s1

References

1. Gaskin, G.J. and J.D. Miller, 1996
Measurement of soil water content using a simplified impedance measuring technique.
J. Agr. Engng Res **63**, 153-160
2. Topp, G.C., J. L. Davis and A. P Annan 1980
Electromagnetic determination of soil water content.
Water Resour. Res **16**(3) 574-582
3. Whalley, W.R. 1993
Considerations on the use of time-domain reflectometry (TDR) for measuring soil moisture content.
Journal of Soil Sci. **44**, 1-9
4. White, I., J.H. Knight, S.J. Zegelin, and Topp, G.C. 1994
Comments on 'Considerations on the use of time-domain reflectometry (TDR) for measuring soil water content' by W R Whalley
Journal of Soil Sci. **45**, 503-508
5. Roth, C.H., M.A. Malicki, and R. Plagge, 1992
Empirical evaluation of the relationship between soil dielectric constant and volumetric water content as the basis for calibrating soil moisture measurements.
Journal of Soil Sci. **43**, 1-13
6. Knight, J.H. 1992
Sensitivity of Time Domain Reflectometry measurements to lateral variations in soil water content.
Water Resour. Res., **28**, 2345-2352
7. Or, D. and J.M. Wraith 1999
Temperature effects on soil bulk dielectric permittivity measured by time domain reflectometry: A physical model.
Water Resour Res., **35**, 371-383

Technical Support

Terms and Conditions of Sale

Our Conditions of Sale (ref: COND: 1/07) set out Delta-T's legal obligations on these matters. The following paragraphs summarise Delta T's position but reference should always be made to the exact terms of our Conditions of Sale, which will prevail over the following explanation.

Delta-T warrants that the goods will be free from defects arising out of the materials used or poor workmanship for a period of twelve months from the date of delivery.

Delta-T shall be under no liability in respect of any defect arising from fair wear and tear, and the warranty does not cover damage through misuse or inexpert servicing, or other circumstances beyond their control.

If the buyer experiences problems with the goods they shall notify Delta-T (or Delta-T's local distributor) as soon as they become aware of such problem.

Delta-T may rectify the problem by replacing faulty parts free of charge, or by repairing the goods free of charge at Delta-T's premises in the UK during the warranty period.

If Delta-T requires that goods under warranty be returned to them from overseas for repair, Delta-T shall not be liable for the cost of carriage or for customs clearance in respect of such goods. However, Delta-T requires that such returns are discussed with them in advance and may at their discretion waive these charges.

Delta-T shall not be liable to supply products free of charge or repair any goods where the products or goods in question have been discontinued or have become obsolete, although Delta-T will endeavour to remedy the buyer's problem.

Delta-T shall not be liable to the buyer for any consequential loss, damage or compensation whatsoever (whether caused by the negligence of the Delta-T, their employees or distributors or otherwise) which arise from the supply of the goods and/or services, or their use or resale by the buyer.

Delta-T shall not be liable to the buyer by reason of any delay or failure to perform their obligations in relation to the goods and/or services if the delay or failure was due to any cause beyond the Delta-T's reasonable control.

Service, Repairs and Spares

Users in countries that have a Delta-T distributor or technical representative should contact them in the first instance.

Spare parts for our own instruments can be supplied and can normally be despatched within a few working days of receiving an order.

Spare parts and accessories for products not manufactured by Delta-T may have to be obtained from our supplier, and a certain amount of additional delay is inevitable.

No goods or equipment should be returned to Delta-T without first obtaining the return authorisation from Delta-T or our distributor.

On receipt of the goods at Delta-T you will be given a reference number. Always refer to this reference number in any subsequent correspondence. The goods will be inspected and you will be informed of the likely cost and delay.

We normally expect to complete repairs within one or two weeks of receiving the equipment. However, if the equipment has to be forwarded to our original supplier for specialist repairs or recalibration, additional delays of a few weeks may be expected. For contact details see below.

Technical Support

Users in countries that have a Delta-T distributor or technical representative should contact them in the first instance.

Technical Support is available on Delta-T products and systems. Your initial enquiry will be acknowledged immediately with a reference number. Make sure to quote the reference number subsequently so that we can easily trace any earlier correspondence.

In your enquiry, always quote instrument serial numbers, software version numbers, and the approximate date and source of purchase where these are relevant.

Contact details:

	Technical Support	Tel: +44 1638 742922
	Delta-T Devices Ltd	Fax: +44 1638 743155
	130 Low Road	E-mail: tech.support@delta-t.co.uk
	Burwell	sales@delta-t.co.uk
	Cambridge CB25 0EJ	Web: www.delta-t.co.uk
	England (UK)	

Appendix 1

Soil-specific Calibration

This note provides details of 2 techniques for generating soil-specific calibrations:

Laboratory calibration for substrates* and non-clay soils

Laboratory calibration for clay soils

* We use the term substrate to refer to any artificial growing medium.

Underlying principle

Soil moisture content (θ) is proportional to the refractive index of the soil ($\sqrt{\varepsilon}$) as measured by the SM300 (see **Calibration** section).

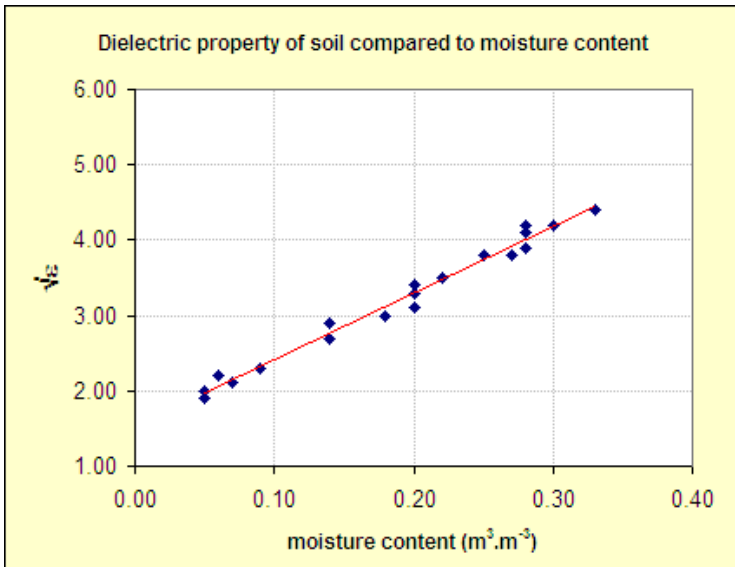

The goal of calibration is to generate two coefficients (a_0 , a_1) which can be used in a linear equation to convert probe readings into soil moisture:

$$\sqrt{\varepsilon} = a_0 + a_1 \times \theta$$

Laboratory calibration for non-clay soils

This is the easiest technique, but it's not suitable for soils that shrink or become very hard when dry.

Equipment you will need:

- SM300 and meter
- Soil corer (if doing a calibration for a cohesive soil rather than sand or a substrate)
- Heat-resistant beaker (≥ 0.5 litre)
- Weighing balance (accurate to < 1 g)
- Temperature controlled oven (for mineral soils or substrates)

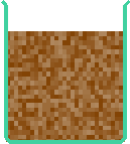
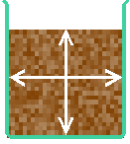
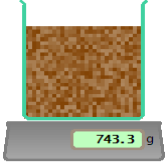
<i>Process</i>	<i>Notes and example</i>
	<p>Collect a damp sample of the soil or substrate.</p> <p>This sample needs to be unchanged from its in-situ density, to be ≥ 0.5 litre, to have the correct dimensions to fit the beaker, and to be generally uniform in water content.</p> <p>For cohesive soils this is most easily done with a soil-corer.</p> <p>Sandy soils can be poured into the beaker, but you should take the subsequent measurements immediately, as the water will quickly begin to drain to the bottom of the beaker.</p> <p>Compressible soils and composts often require measurement of the in-situ density and then need to be carefully reconstituted at that density within the beaker.</p>
	<p>Measure the volume occupied by the sample.</p> <p>$L_s = 463.5\text{ml}$</p>
	<p>Weigh the sample, including the beaker.</p> <p>$W_w = 743.3\text{g}$</p>

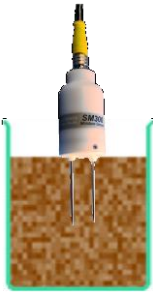

Insert SM300 into the sample and record its output in Volts.

$$V_w = 0.350 V$$

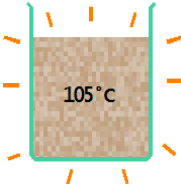

Dry the sample thoroughly.

With mineral soils this is usually achieved by keeping it in the oven at 105°C for several hours or days (the time required depends on the sample size and porosity).

For organic soils and composts it's usual to air-dry the sample to avoid burning off any volatile fractions.

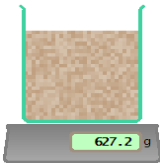

Weigh the dry sample in the beaker.

$$W_0 = 627.2g$$

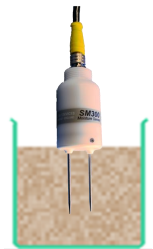

Re-insert the SM300 into the dry sample and record this reading.

$$V_0 = 0.051 V$$

Calculate α_0

For the SM300,

In the dry soil $V = V_0 = 0.051$ Volts

Substitute this into the equation

$$\sqrt{\epsilon} = 1.0 + 14.868V - 33.56V^2 + 51.223V^3 - 36.283V^4 + 9.715V^5$$

gives $\sqrt{\epsilon_0} = 1.68$

Since $\theta_0 = 0$, this is the value needed for α_0

$$\alpha_0 = 1.68$$

<p>Calculate θ_w</p>	<p>The water content of the wet soil, θ_w, can be calculated from the weight of water lost during drying, $(W_w - W_0)$ and its volume, L_s:</p> $\theta_w = (W_w - W_0)/L_s = (743.3 - 627.2)/463.5 = 0.25$ <p>$\theta_w = 0.25$</p>
<p>Calculate a_1</p>	<p>In the wet soil $V = V_w = 0.350$ Volts and substituting gives</p> $\sqrt{\varepsilon_w} = 3.79$ <p>Finally</p> $a_1 = (\sqrt{\varepsilon_w} - \sqrt{\varepsilon_0})/(\theta_w - \theta_0) = (3.79 - 1.68)/(0.25 - 0) = 8.44$ <p>$a_1 = 8.44$</p>
<p>Result</p>	<p>$a_0 = 1.68$</p> <p>$a_1 = 8.44$</p>

In this example this soil is now calibrated.

You can now use these two numbers in place of the standard mineral or organic calibration factors to convert SM300 readings into volumetric water content θ using:

$$\sqrt{\varepsilon} = a_0 + a_1 \times \theta$$

See also page [Underlying principle](#) on page 35

Laboratory calibration for clay soils

This technique is adapted to avoid the near-impossibility of inserting the SM300 into completely dry clay soil. It requires taking measurements at 2 significantly different, but still damp, moisture levels.

Equipment you will need:

- SM300 and meter
- Soil corer
- Heat-resistant beaker ($\geq 500\text{ml}$)
- Weighing balance (accurate to $< 1\text{g}$)
- Temperature controlled oven

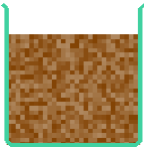
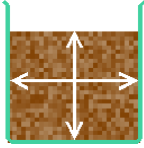
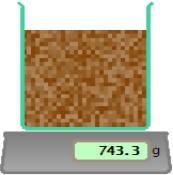
<i>Process</i>	<i>Notes and example</i>
	<p>Collect a <u>wet</u> sample of the clay soil: 25 to 30% water content would be ideal.</p> <p>This sample needs to be unchanged from its in-situ density, to be $\geq 500\text{ml}$, to have the correct dimensions to fit the beaker, and to be generally uniform in water content.</p> <p>This is most easily done with soil-corer.</p>
	<p>Measure the volume occupied by the sample.</p> <p>$L_s = 463.5\text{ml}$</p>
	<p>Weigh the wet sample, including the beaker.</p> <p>$W_w = 743.3\text{g}$</p>

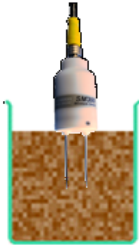

Insert SM300 into the wet sample and record its output in Volts.

$$V_w = 0.349 V$$

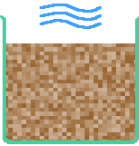

Dry the sample until still moist, ~15% water content. Gentle warming can be used to accelerate the process, but take care not to over-dry in places, and allow time for the water content to equilibrate throughout the sample before taking a reading.

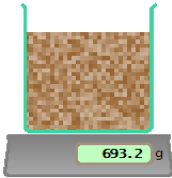

Reweigh.

$$W_m = 693.2g$$

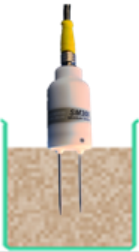

Re-measure with the SM300.

$$V_m = 0.180 V$$

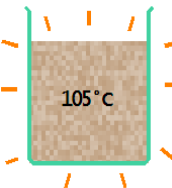

Dry the sample thoroughly.

With clay soils this is usually achieved by keeping it in the oven at 105°C for several hours or days (the time required depends on the sample size and porosity).

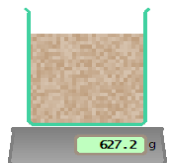

Weigh the dry sample in the beaker.

$$W_o = 627.2g$$

Calculations	<p>Substituting in the SM300 equation</p> $\sqrt{\varepsilon} = 1.0 + 14.868V - 33.56V^2 + 51.223V^3 - 36.283V^4 + 9.715V^5$ <p>provides two dielectric values, $\sqrt{\varepsilon_w}$ and $\sqrt{\varepsilon_m}$, at two known water contents, θ_w and θ_m</p>
For the wet soil	<p>Substituting $V_w = 0.349$ gives</p> $\sqrt{\varepsilon_w} = 3.79 = a_0 + a_1 \cdot \theta_w$ <p>for $\theta_w = (743.3 - 627.2)/463.5 = 0.25$</p>
For the moist soil	<p>Substituting $V_m = 0.180$ gives</p> $\sqrt{\varepsilon_m} = 2.85 = a_0 + a_1 \cdot \theta_m$ <p>For $\theta_m = (693.2 - 627.2)/463.5 = 0.14$</p>
Calculate a_1	<p>Then $a_1 = (\sqrt{\varepsilon_w} - \sqrt{\varepsilon_m})/(\theta_w - \theta_m) = 8.69$</p> <p>$a_1 = 8.69$</p>
Calculate a_0	<p>and $a_0 = \sqrt{\varepsilon_w} - (a_1 \cdot \theta_w) = 1.61$</p> <p>$a_0 = 1.61$</p>
Result	<p>$a_1 = 8.69$</p> <p>$a_0 = 1.61$</p>

In this example this soil is now calibrated.

You can now use these two numbers in place of the standard mineral or organic calibration factors to convert SM300 readings into volumetric water content θ using:

$$\sqrt{\varepsilon} = a_0 + a_1 \times \theta$$

See also page [Underlying principle](#) on page 35

Appendix 2:

The SM300 Temperature Sensor

Soil moisture content is used with the measurement of soil temperature in several major application areas including the following:

Global warming and climate studies

Soils contain more than four times as much carbon as the CO₂ in the atmosphere, and each year they release about ten times as much carbon through soil respiration as the combined release through burning fossil fuels. Soil respiration rates are particularly sensitive to changes in both temperature and the moisture content of the soil.

Soils also have a significant interaction with climate as they store and release heat – soil temperature provides a measure of the energy partitioning, which in turn is strongly influenced by the effect of soil moisture on thermal conductivity.

Civil engineering

Most civil engineering projects depend critically on the mechanical properties of soils. Those properties are effected by many different parameters, but moisture content and temperature are the two variables that are most likely to change over time, so may be measured together in order to assess their impact.

Soil contamination and hydrogeology

Soil moisture is the main determinant for the movement of contaminants and solutes through soils, but temperature also has a significant influence so they are often measured together.

Agriculture

Temperature may be measured alongside soil water content for studies of evapotranspiration, soil water balance and irrigation. Soil strength and seedling emergence depend on soil moisture and temperature, and both need to be taken into account when deciding when to sow.

SM300 Temperature Measurement

The SM300 Temperature sensor uses a thermistor with a 10K resistance at 25 °C. However:

- A. This sensor has a different response curve from the more widely used 10K3A1B type. The response curve is given in the Resistance to Temperature Lookup Table on page 45.
- B. The Thermistor circuit shares the Power 0V wire. If the thermistor is measured when the SM300 is powered, the measured resistance measurement may need to be corrected for 18 mA SM300 supply current.

GP1 and DL6 loggers

The 'SM300 Temperature' sensor type in DeltaLINK performs the supply current correction.

DL2e Logger

The linearization table for the 'S3T' sensor code ('SM300 Temperature') provides supply current correction for the **SMSC/lw-05** 5m logger cable ONLY.

Extension cables and other cable lengths

Create your own custom sensor type(s) and linearization tables as described in Ls2Win Help topic, How to... 'Add or modify a sensor type in the sensor library'.

Enter corrected resistance values (R) for each linearization table point:

$$R = R5 + (0.059 \times Lex) \text{ k}\Omega \quad (\text{See footnote}^8)$$

$$\text{or} \quad R = R5 + (0.9 \times Rc - 0.297) \text{ k}\Omega$$

where

R5 = value supplied in the table for the 'SM300 Temp, 5m' sensor type.

Lex = length of extension cable, excluding the 5m of **SMSC/lw-05** cable.

Rc = total cable resistance, including resistance of **SMSC/lw-05** cable, if fitted.

⁸ Note: This equation only applies to Delta-T SM300 cables

Other loggers

If your logger can be programmed so that the soil moisture and temperature readings can be taken sequentially (i.e. the sensor is not powered during the temperature reading), then the temperature can be obtained directly from the response curve on page 45.

Otherwise, correct the resistance reading before applying the response curve.

You need to know the resistance of the Power 0V wire in the SM300 cable (R_c) and establish whether your logger uses voltage or current excitation for resistance measurement.

Voltage Excited

You need to know the excitation voltage (V_{ref}), reference resistance (R_{ref}). The correct resistance is given by the equation:

$$R = a_0 + a_1 * R_{meas}$$

Where:

$$a_0 = - I_c \cdot R_c \cdot R_{ref} / V_{ref}$$

$$a_1 = 1 - I_c \cdot R_c / V_{ref}$$

$$I_c = 18 \text{ mA (SM300 sensor supply current)}$$

For Delta-T **EXT/5W-xx** series cables:

$$R_c = 0.066 \Omega \cdot \text{m}^{-1}$$

For the **SMSC/lw-05** 5m logger cable

$$R_c = 0.33 \Omega$$

Current Excited

You need to know the excitation current (I_{ex}).

The corrected resistance is given by the equation (using terms defined above):

$$R = R_{meas} - I_c \cdot R_c / I_{ex}$$

Effect of Temperature on Water Permittivity

See **Temperature response of soil moisture readings** on page 27

Resistance to Temperature Lookup Table

Temperature degrees C	Resistance Kohms
-25	90.538
-22	77.683
-19	66.854
-16	57.713
-13	49.968
-10	43.379
-7	37.759
-4	32.957
-1	28.844
2	25.299
5	22.244
8	19.608
11	17.321
14	15.334
17	13.606
20	12.098
23	10.780
26	9.623
29	8.611
32	7.720
35	6.935
38	6.241
41	5.627
44	5.080
47	4.595
50	4.162
53	3.775
56	3.430
59	3.121
62	2.843
65	2.593

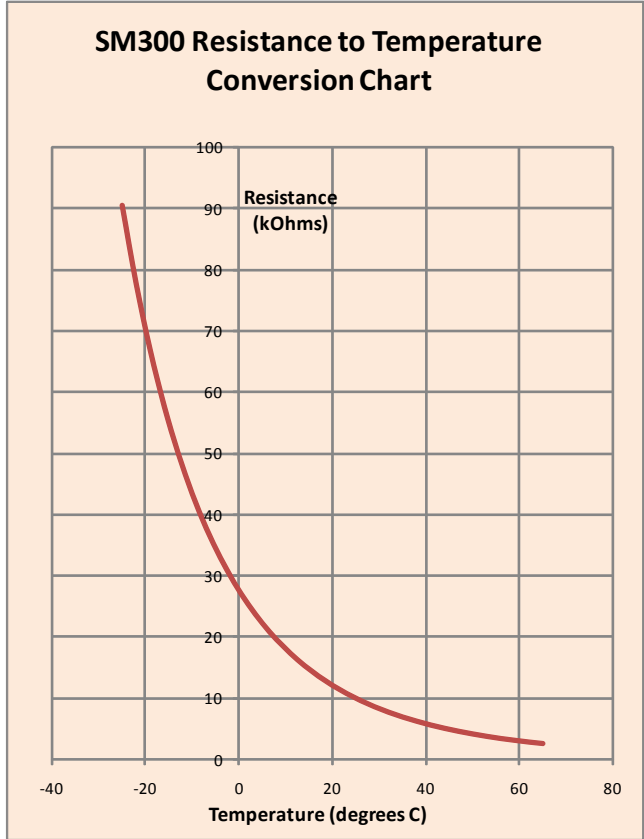

Note: This table has been optimised for use as a look-up table. To minimise linear interpolation errors the data points fall either side of the manufacturers' specified sensor response curve. This helps optimise the overall accuracy of readings.

Index

A

Agriculture, 42
Air reading, 24
Auger, 7

C

Cable Connections, 10
Cable length correction, 43
Calibration
 check, 24
 generalised, 21
 sensor, 20, 21
 soil, 18, 21
 Soil, 35
 soil-specific, 35
Care and safety, 8
Care and Safety, 8
Certification
 emc, 29
Civil engineering, 42
climate, 42
Conductivity response, 26
Connections, 12
contamination, 42
Conversions
 linearisation table, 19, 20
 polynomial, 19, 20
Copyright, 2

D

Data logger, 15, 22, 23, 24
 DL2e, 22, 23
 DL6, 23
 GP1, 13, 23

 other, 15
Definitions, 30
Description, 5
Dielectric
 performance, 20
 refractive index, 17, 18, 35
Dimensions, 6
DL6, 13

E

EMC, 2EG29
9
Extension cables, 10

F

FCC compliance, 29
Features, 5

G

Global warming, 42
GP1, 12, 13, 23

H

HH2, 7, 16, 17, 23, 24
hydrogeology, 42

I

Installation
 buried, 11
 insertion rod, 11
 surface, 11

L

Linearisation table, 21
volts to %vol, 15, 22

M

M12-5w-05, 43
Meter, 23
Moisture content, 5, 9, 32, 35

O

Organic and Mineral, 31

P

Parts, 7
Patent, 2
Permittivity, 9, 17, 32
Polynomial conversion, 21

R

References, 32
Regulatory information, 29
Rods, 8, 9, 11

S

Sales code, 7
Salinity, 31

Sampling Volume, 28
Servicing, 34

Soil

clay, 18, 19, 30, 35, 36, 39
mineral, 17, 19, 21, 36, 37, 40
organic, 17, 19, 21, 31, 37
stony, 11

soil calibrations, 19
Specifications, 2, 25

T

Technical support, 33, 34

Temperature

cable length correction, 15, 43
Temperature response of soil moisture
readings, 27
Temperature sensor cable length
correction, 44
Temperature Sensor Lookup Table, 45
Troubleshooting, 23

V

Volumetric Soil Moisture, 30

W

Warning : Do not touch the pins, 24