

Panasonic®

Model No.

TH-85PB1E
TH-103PB1E

Operating Instructions Display Operations Interactive Plasma Display



English

Please read these instructions before operating your set and retain them for future reference.

HDMI



TQB0E2304U

Dear Panasonic Customer

Welcome to the Panasonic family of customers. We hope that you will have many years of enjoyment from your new Plasma Display.

To obtain maximum benefit from your set, please read these Instructions before making any adjustments, and retain them for future reference.

Retain your purchase receipt also, and note down the model number and serial number of your set in the space provided on the rear cover of these instructions.

Visit our Panasonic Web Site <http://panasonic.net>

Table of Contents

Important Safety Notice	3	Touch-Pen Settings	34
Safety Precautions	4	Screensaver (For preventing image retention)	35
Accessories	7	Setup of Screensaver Time	36
Accessories Supply	7	Reduces screen image retention	37
Remote Control Batteries	8	Extended life settings	37
Connections	9	ECO Mode settings	40
AC cord connection and fixing, cable fixing.....	9	Customizing the Input labels	41
Video equipment connection	10	Function Button Settings	42
AUDIO OUT Terminals connection	11	No activity power off	43
VIDEO and COMPONENT / RGB IN connection ...	11	Menu Display Duration / OSD Brightness	43
HDMI connection	12	OSD Language	43
DVI-D IN connection.....	12	Display orientation	43
PC Input Terminals connection.....	13	Setup for MULTI DISPLAY	44
SERIAL Terminals connection	14	How to Setup MULTI DISPLAY	44
Power On / Off	15	ID Remote Control Function	45
Selecting the input signal	17	Setup for Portrait	46
Basic Controls	18	How to setup Portrait.....	46
ASPECT Controls	20	Setup for Input Signals	48
Digital Zoom	21	Component / RGB-in select.....	48
On-Screen Menu Displays	22	YUV / RGB-in select.....	48
Adjusting Pos./Size	23	Signal menu	49
Picture Adjustments	26	Options Adjustments	52
Advanced settings	27	Weekly Command Timer	55
Picture Profiles	28	Audio input select	57
Saving profiles	29	Input Search	58
Loading profiles	30	Troubleshooting	59
Editing profiles	30	List of Aspect Modes	60
Sound Adjustment	31	Applicable Input Signals	61
SDI Sound Output	31	Shipping condition	62
Setup menu	32	Command list of Weekly Command Timer	63
Day/Time Setup / On/Off Timer Setup	33	Specifications	64
Day/Time Setup.....	33		
On/Off Timer Setup.....	33		

Important Safety Notice

WARNING

- 1) To prevent damage which may result in fire or shock hazard, do not expose this appliance to dripping or splashing.
Do not place containers with water (flower vase, cups, cosmetics, etc.) above the set. (including on shelves above, etc.)
No naked flame sources, such as lighted candles, should be placed on / above the set.
- 2) To prevent electric shock, do not remove cover. No user serviceable parts inside. Refer servicing to qualified service personnel.
- 3) Do not remove the earthing pin on the power plug. This apparatus is equipped with a three pin earthing-type power plug. This plug will only fit an earthing-type power outlet. This is a safety feature. If you are unable to insert the plug into the outlet, contact an electrician.
Do not defeat the purpose of the earthing plug.
- 4) To prevent electric shock, ensure the earthing pin on the AC cord power plug is securely connected.

CAUTION

This appliance is intended for use in environments which are relatively free of electromagnetic fields. Using this appliance near sources of strong electromagnetic fields or where electrical noise may overlap with the input signals could cause the picture and sound to wobble or cause interference such as noise to appear. To avoid the possibility of harm to this appliance, keep it away from sources of strong electromagnetic fields.

IMPORTANT: THE MOULDED PLUG

FOR YOUR SAFETY, PLEASE READ THE FOLLOWING TEXT CAREFULLY.

This display is supplied with a moulded three pin mains plug for your safety and convenience. A 13 amp fuse is fitted in this plug. Shall the fuse need to be replaced, please ensure that the replacement fuse has a rating of 13 amps and that it is approved by ASTA or BSI to BS1362.

Check for the ASTA mark  or the BSI mark  on the body of the fuse.

If the plug contains a removable fuse cover, you must ensure that it is refitted when the fuse is replaced.

If you lose the fuse cover the plug must not be used until a replacement cover is obtained.

A replacement fuse cover can be purchased from your local Panasonic dealer.

Do not cut off the mains plug.

Do not use any other type of mains lead except the one supplied with this display.

The supplied mains lead and moulded plug are designed to be used with this display to avoid interference and for your safety.

If the socket outlet in your home is not suitable, get it changed by a qualified electrician.

If the plug or mains lead becomes damaged, purchase a replacement from an authorized dealer.

WARNING : — THIS DISPLAY MUST BE EARTHED.

How to replace the fuse. Open the fuse compartment with a screwdriver and replace the fuse.

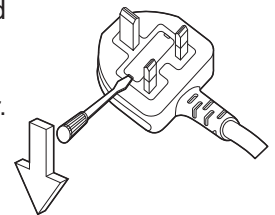

Trademark Credits

- VGA is a trademark of International Business Machines Corporation.
- Macintosh is a registered trademark of Apple Inc., USA.
- SVGA, XGA, SXGA and UXGA are registered trademarks of the Video Electronics Standard Association.
Even if no special notation has been made of company or product trademarks, these trademarks have been fully respected.
- HDMI, the HDMI Logo, and High-Definition Multimedia Interface are trademarks or registered trademarks of HDMI Licensing LLC in the United States and other countries.

Note:

Do not allow a still picture to be displayed for an extended period, as this can cause a permanent image retention to remain on the Plasma Display.

Examples of still pictures include logos, video games, computer images, teletext and images displayed in 4:3 mode.

Safety Precautions

WARNING

■ Setup

This Plasma Display is for use only with the following optional accessories. Use with any other type of optional accessories may cause instability which could result in the possibility of injury.

(All of the following accessories are manufactured by Panasonic Corporation.)

- Pedestal TY-ST85P12 (for TH-85PB1E),
TY-ST103PF9 (for TH-103PB1E)
- Mobile stand for Display TY-ST85PB1 (for TH-85PB1E)
- Floor stand TY-ST85PF12 (for TH-85PB1E)
- Wall-hanging bracket (vertical) TY-WK85PV12 (for TH-85PB1E),
TY-WK103PV9 (for TH-103PB1E)
- Ceiling-hanging bracket TY-CE85PS12 (for TH-85PB1E),
TY-CE103PS10 (for TH-103PB1E)
- BNC Dual Video Terminal Board TY-FB9BD
- HD-SDI Terminal Board TY-FB9HD
- HD-SDI Terminal Board with audio TY-FB10HD
- Dual Link HD-SDI Terminal Board TY-FB11DHD
- Dual HDMI Terminal Board TY-FB10HMD
- DVI-D Terminal Board TY-FB11DD
- AV Terminal Box TY-TB10AV
- Electronic Pen kit for Interactive Plasma Display TY-TPEN1PBW
- Remote Pointer kit for Interactive Plasma Display TY-TPEN1RMW
- Wireless Module ET-WM200E

Always be sure to ask a qualified technician to carry out set-up.

Small parts can present choking hazard if accidentally swallowed. Keep small parts away from young children. Discard unneeded small parts and other objects, including packaging materials and plastic bags/sheets to prevent them from being played with by young children, creating the potential risk of suffocation.

Do not place the Plasma Display on sloped or unstable surfaces, and ensure that the Plasma Display does not hang over the edge of the base.

- The Plasma Display may fall off or tip over.

Do not place any objects on top of the Plasma Display.

- If water spills onto the Plasma Display or foreign objects get inside it, a short-circuit may occur which could result in fire or electric shock. If any foreign objects get inside the Plasma Display, please consult your local Panasonic dealer.

Transport only in upright position!

- Transporting the unit with its display panel facing upright or downward may cause damage to the internal circuitry.

Ventilation should not be impeded by covering the ventilation openings with items such as newspapers, table cloths and curtains.

**For sufficient ventilation;
(TH-85PB1E)**

If using the pedestal (optional accessory), leave a space of 10 cm or more at the top, left and right, and 15 cm or more at the rear, and also keep the space between the bottom of the display and the floor surface.

If using some other setting-up method, follow the manual of it. (If there is no specific indication of installation dimension in the installation manual, leave a space of 10 cm or more at the top, bottom, left and right, and 15 cm or more at the rear.)

(TH-103PB1E)

If using the pedestal (optional accessory), leave a space of 30 cm or more at the top, left and right, and 20 cm or more at the rear, and also keep the space between the bottom of the display and the floor surface.

If using some other setting-up method, follow the manual of it. (If there is no specific indication of installation dimension in the installation manual, leave a space of 30 cm or more at the top, bottom, left and right, and 20 cm or more at the rear.)

When installing the Plasma Display vertically;

Turn down the power switch for the downward direction when you install the Plasma Display vertically. And set "Display orientation" to "Portrait" in Setup menu. (see page 43)

■ **When using the Plasma Display**

The Plasma Display is designed to operate on 220 - 240 V AC, 50/60 Hz.

Do not cover the ventilation holes.

- Doing so may cause the Plasma Display to overheat, which can cause fire or damage to the Plasma Display.

Do not stick any foreign objects into the Plasma Display.

- Do not insert any metal or flammable objects into the ventilations holes or drop them onto the Plasma Display, as doing so can cause fire or electric shock.

Do not remove the cover or modify it in any way.

- High voltages which can cause severe electric shocks are present inside the Plasma Display. For any inspection, adjustment and repair work, please contact your local Panasonic dealer.

Ensure that the mains plug is easily accessible.

An apparatus with CLASS I construction shall be connected to a mains socket outlet with a protective earthing connection.

Do not use any power supply cord other than that provided with this unit.

- Doing so may cause fire or electric shocks.

Securely insert the power supply plug as far as it will go.

- If the plug is not fully inserted, heat may be generated which could cause fire. If the plug is damaged or the wall socket is loose, they shall not be used.

Do not handle the power supply plug with wet hands.

- Doing so may cause electric shocks.

Do not do anything that may damage the power cable. When disconnecting the power cable, pull on the plug body, not the cable.

- Do not damage the cable, make any modifications to it, place heavy objects on top of it, heat it, place it near any hot objects, twist it, bend it excessively or pull it. To do so may cause fire and electric shock. If the power cable is damaged, have it repaired at your local Panasonic dealer.

If the Plasma Display is not going to be used for any prolonged length of time, unplug the power supply plug from the wall outlet.

To prevent the spread of fire, keep candles or other open flames away from this product at all times.



■ **If problems occur during use**

If a problem occurs (such as no picture or no sound), or if smoke or an abnormal odour starts to come out from the Plasma Display, immediately unplug the power supply plug from the wall outlet.

- If you continue to use the Plasma Display in this condition, fire or electric shock could result. After checking that the smoke has stopped, contact your local Panasonic dealer so that the necessary repairs can be made. Repairing the Plasma Display yourself is extremely dangerous, and shall never be done.

If water or foreign objects get inside the Plasma Display, if the Plasma Display is dropped, or if the cabinet becomes damaged, disconnect the power supply plug immediately.

- A short circuit may occur, which could cause fire. Contact your local Panasonic dealer for any repairs that need to be made.

Safety Precautions

CAUTION

■ When using the Plasma Display

Do not bring your hands, face or objects close to the ventilation holes of the Plasma Display.

- Heated air comes out from the ventilation holes at the top of Plasma Display will be hot. Do not bring your hands or face, or objects which cannot withstand heat, close to this port, otherwise burns or deformation could result.

Be sure to disconnect all cables before moving the Plasma Display.

- If the Plasma Display is moved while some of the cables are still connected, the cables may become damaged, and fire or electric shock could result.

Disconnect the power supply plug from the wall socket as a safety precaution before carrying out any cleaning.

- Electric shocks can result if this is not done.

Clean the power cable regularly to prevent it becoming dusty.

- If dust built up on the power cord plug, the resultant humidity can damage the insulation, which could result in fire. Pull the power cord plug out from the wall outlet and wipe the mains lead with a dry cloth.

Do not burn or breakup batteries.

- Batteries must not be exposed to excessive heat such as sunshine, fire or the like.

This Plasma Display radiates infrared rays, therefore it may affect other infrared communication equipment. Install your infrared sensor in a place away from direct or reflected light from your Plasma Display.

Cleaning and maintenance

The front of the display panel has been specially treated. Wipe the panel surface gently using only a cleaning cloth or a soft, lint-free cloth.

- If the surface is particularly dirty, wipe with a soft, lint-free cloth which has been soaked in pure water or water in which neutral detergent has been diluted 100 times, and then wipe it evenly with a dry cloth of the same type until the surface is dry.
- Do not scratch or hit the surface of the panel with fingernails or other hard objects, otherwise the surface may become damaged. Furthermore, avoid contact with volatile substances such as insect sprays, solvents and thinner, otherwise the quality of the surface may be adversely affected.

If the cabinet becomes dirty, wipe it with a soft, dry cloth.

- If the cabinet is particularly dirty, soak the cloth in water to which a small amount of neutral detergent has been added and then wring the cloth dry. Use this cloth to wipe the cabinet, and then wipe it dry with a dry cloth.
- Do not allow any detergent to come into direct contact with the surface of the Plasma Display. If water droplets get inside the unit, operating problems may result.
- Avoid contact with volatile substances such as insect sprays, solvents and thinner, otherwise the quality of the cabinet surface may be adversely affected or the coating may peel off. Furthermore, do not leave it for long periods in contact with articles made from rubber or PVC.

Using the electronic pen

The electronic pen may malfunction when interfered with by environmental noise.

If it malfunctions, move it away from the Plasma Display once and then use it again.

Accessories

Accessories Supply

Check that you have the accessories and items shown

Operating
Instruction book

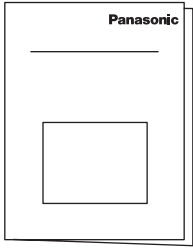

CD-ROM × 1

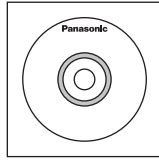

- Operating Instructions
- Display Operations
- Network Operations
- Software license statements
- GNU GENERAL PUBLIC LICENSE
- GNU LESSER GENERAL PUBLIC LICENSE

Remote Control
Transmitter
N2QAYB000691



Batteries for the Remote
Control Transmitter
(R6 (UM3) Size × 2)

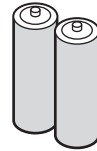

Power supply cord

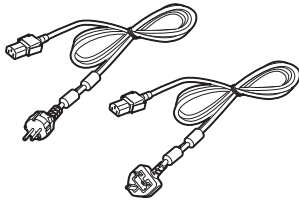

Fixing band × 2
TMME203

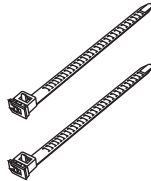

TH-85PB1E
Clamper × 1
TMM15412-2

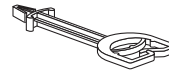

Use the clamper when
connecting a LAN cable.
(refer to “Operating Instructions,
Network Operations”)

Ferrite core × 2
J0KG00000014

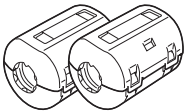

Use the Ferrite cores to comply with the EMC standard.
(refer to “Operating Instructions, Network Operations”)

These accessories will be used by professional installers when they install the unit.

TH-85PB1E

Eyebolt cap × 1



Eyebolt × 1
(M12)



Blind sheet × 1

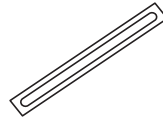

Allen wrench



TH-103PB1E

Eyebolt cap × 3



Blind sheet × 1

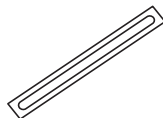

Allen wrench



Remote Control Batteries

Requires two R6 batteries.

1. Pull and hold the hook, then open the battery cover.
2. Insert batteries - note correct polarity (+ and -).
3. Replace the cover.

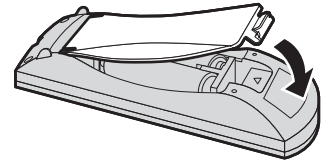
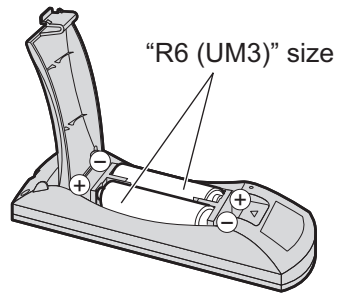
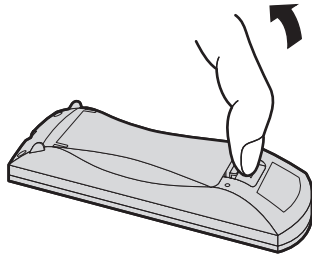

Helpful Hint:

For frequent remote control users, replace old batteries with Alkaline batteries for longer life.

Precaution on battery use

Incorrect installation can cause battery leakage and corrosion that will damage the remote control transmitter. Disposal of batteries should be in an environment-friendly manner.

Observe the following precaution:

1. Batteries shall always be replaced as a pair. Always use new batteries when replacing the old set.
2. Do not combine a used battery with a new one.
3. Do not mix battery types (example: "Zinc Carbon" with "Alkaline").
4. Do not attempt to charge, short-circuit, disassemble, heat or burn used batteries.
5. Battery replacement is necessary when remote control acts sporadically or stops operating the Plasma Display set.
6. Do not burn or breakup batteries.
7. Batteries must not be exposed to excessive heat such as sunshine, fire or the like.

Connections

AC cord connection and fixing, cable fixing

TH-85PB1E

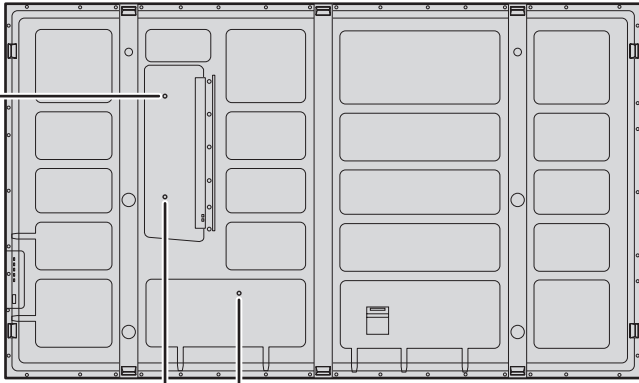

TH-103PB1E

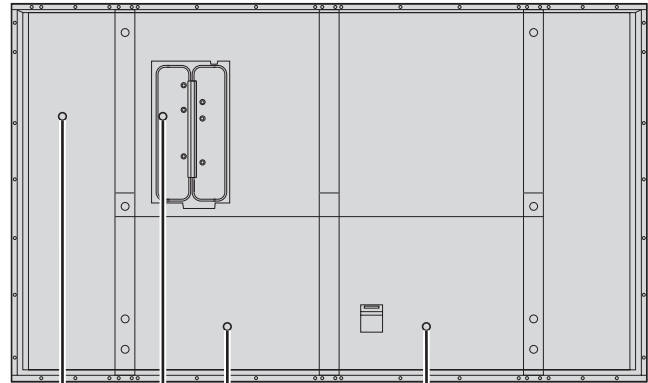

- AC cord fixing

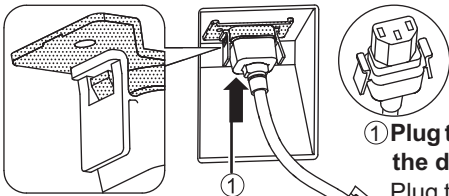

- ① Plug the AC cord into the display unit. Plug the AC cord until it clicks.
- ② Fix the AC cord with the clamper.

Note:
Make sure that the AC cord is locked on both the left and right sides.

Close

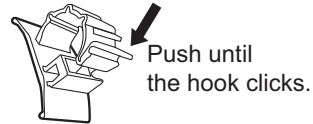

Open

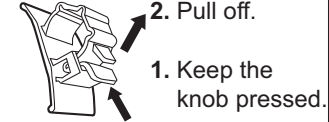

Unplug the AC cord

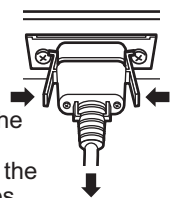

Unplug the AC cord pressing the two knobs.

Note:
When disconnecting the AC cord, be absolutely sure to disconnect the AC cord plug at the socket outlet first.

- Cable fixing bands

Secure any excess cables with bands as required.

Note:

Two fixing bands are supplied with this unit. In case of securing cables at three (four) positions, please purchase it separately.

Pass the attached cable fixing band through the clip as shown in the figure.

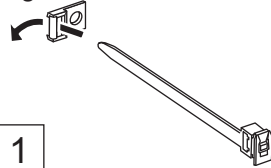

To secure cables connected to Terminals, wrap the cable fixing band around them then pass the pointed end through the locking block, as shown in the figure. **While ensuring there is sufficient slack in cables to minimize stress (especially in the power cord), firmly bind all cables with the supplied fixing band.**

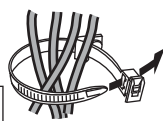

To tighten:

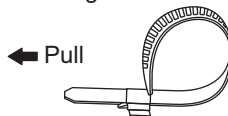

To loosen:

Push the catch

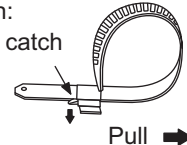

Video equipment connection

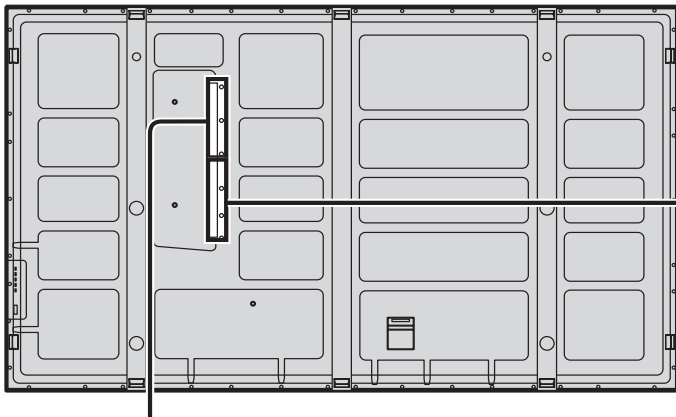

SLOT: Terminal board (optional accessories) insert slot (see page 4)

Note:
The lower side slot is for terminal board with 2-slot width. The terminal board with 1-slot width does not function when installed in the lower side slot.

AV IN (VIDEO): Composite Video Input Terminal (see page 11)
COMPONENT/RGB IN: Component/RGB Video Input Terminal (see page 11)

SERIAL:
Control the Plasma Display by connecting to PC. (see page 14)

AUDIO OUT
Connect to sound equipment. (see page 11)

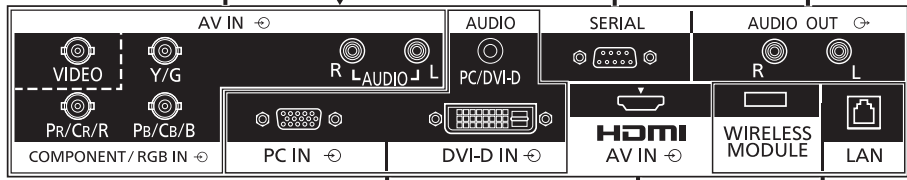

DVI-D IN: DVI-D Input Terminal (see page 12)
PC IN: PC Input Terminal Connect to video terminal of PC or equipment with Y, P_B(C_B) and P_R(C_R) output. (see page 13)

AV IN (HDMI): HDMI Input Terminal (see page 12)
Connect to video equipment such as VCR or DVD player.

WIRELESS MODULE, LAN:
Refer to “Operating Instructions, Network Operations”.

AUDIO OUT Terminals connection

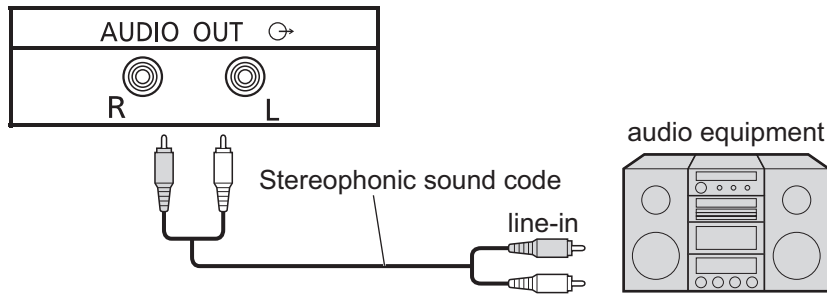

VIDEO and COMPONENT / RGB IN connection

Note:

Additional equipment, cables and adapter plugs shown are not supplied with this set.

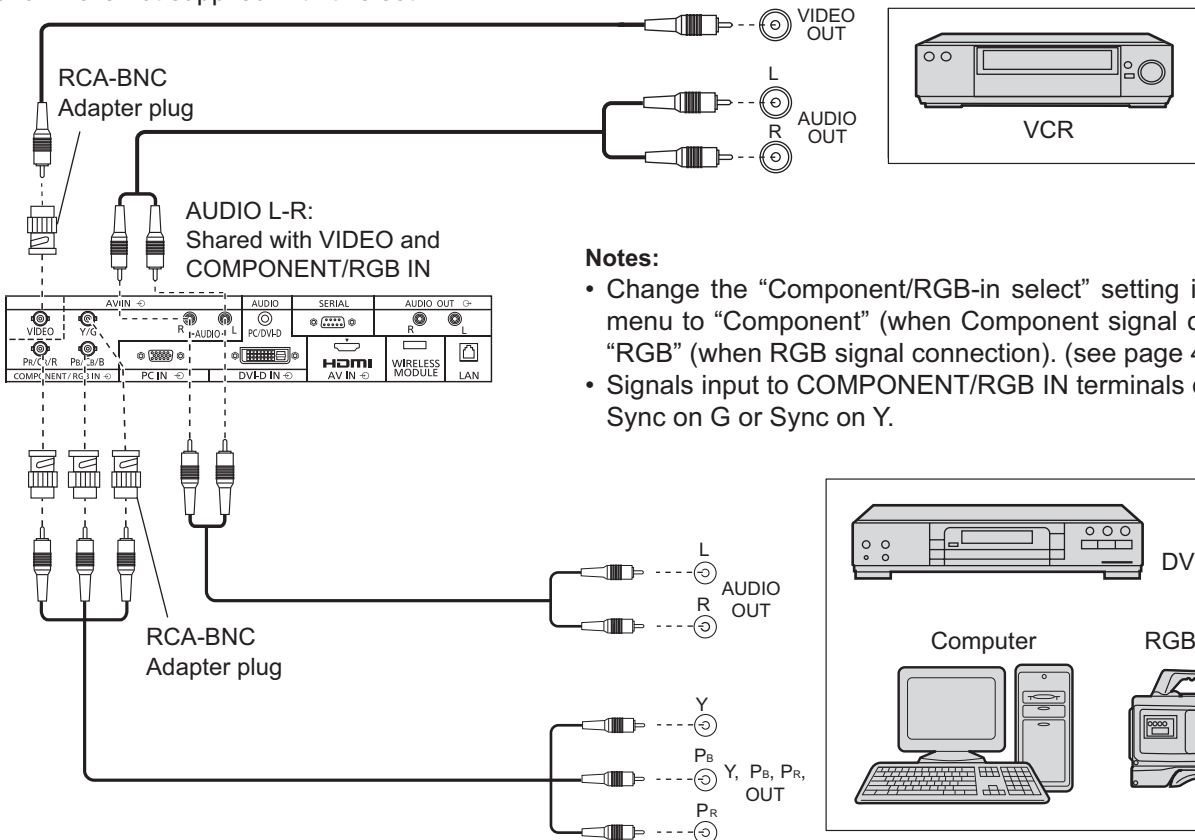

HDMI connection

[Pin assignments and signal names]

Pin No.	Signal name	Pin No.	Signal name
①	T.M.D.S Data2+	⑪	T.M.D.S Clock Shield
②	T.M.D.S Data2 Shield	⑫	T.M.D.S Clock-
③	T.M.D.S Data2-	⑬	CEC
④	T.M.D.S Data1+	⑭	Reserved (N.C. on device)
⑤	T.M.D.S Data1 Shield		
⑥	T.M.D.S Data1-	⑮	SCL
⑦	T.M.D.S Data0+	⑯	SDA
⑧	T.M.D.S Data0 Shield	⑰	DDC/CEC Ground
⑨	T.M.D.S Data0-	⑱	+5V Power
⑩	T.M.D.S Clock+	⑲	Hot Plug Detect

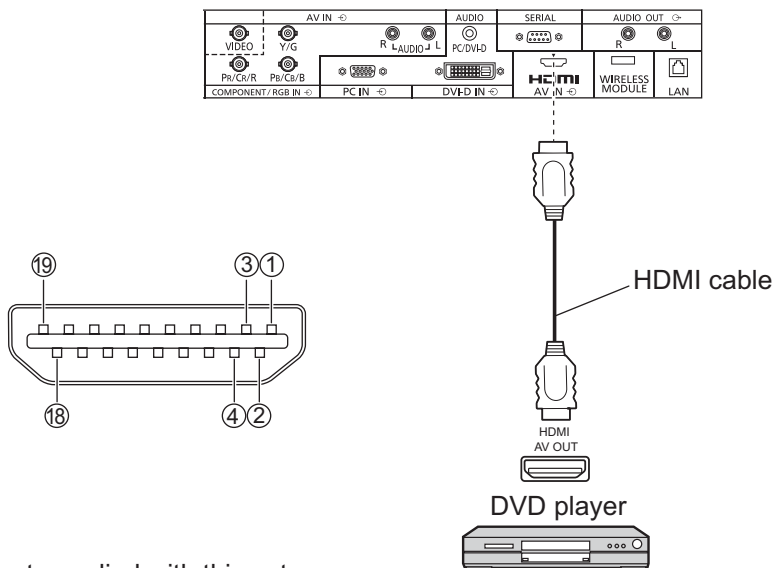

Note:

Additional equipment and HDMI cable shown are not supplied with this set.

DVI-D IN connection

PC with DVI-D video out

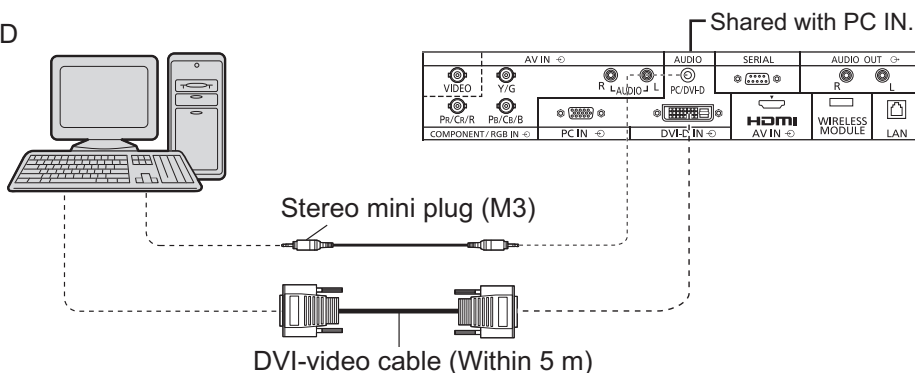

DVI-D Input Connector Pin Layouts

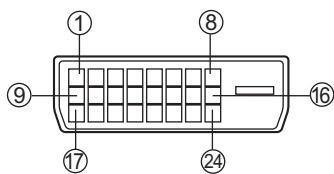

Connection port view

Pin No.	Signal Name	Pin No.	Signal Name
①	T.M.D.S. data 2-	⑬	_____
②	T.M.D.S. data 2+	⑭	+5 V DC
③	T.M.D.S. data 2 shield	⑮	Ground
④	_____	⑯	Hot plug detect
⑤	_____	⑰	T.M.D.S. data 0-
⑥	DDC clock	⑱	T.M.D.S. data 0+
⑦	DDC data	⑲	T.M.D.S. data 0 shield
⑧	_____	⑳	_____
⑨	T.M.D.S. data 1-	㉑	_____
⑩	T.M.D.S. data 1+	㉒	T.M.D.S. clock shield
⑪	T.M.D.S. data 1 shield	㉓	T.M.D.S. clock+
⑫	_____	㉔	T.M.D.S. clock-

Notes:

- Additional equipment and cables shown are not supplied with this set.
- Use the DVI-D cable complying with the DVI standard. Image deterioration may occur depending on the length or the quality of the cable.

PC Input Terminals connection

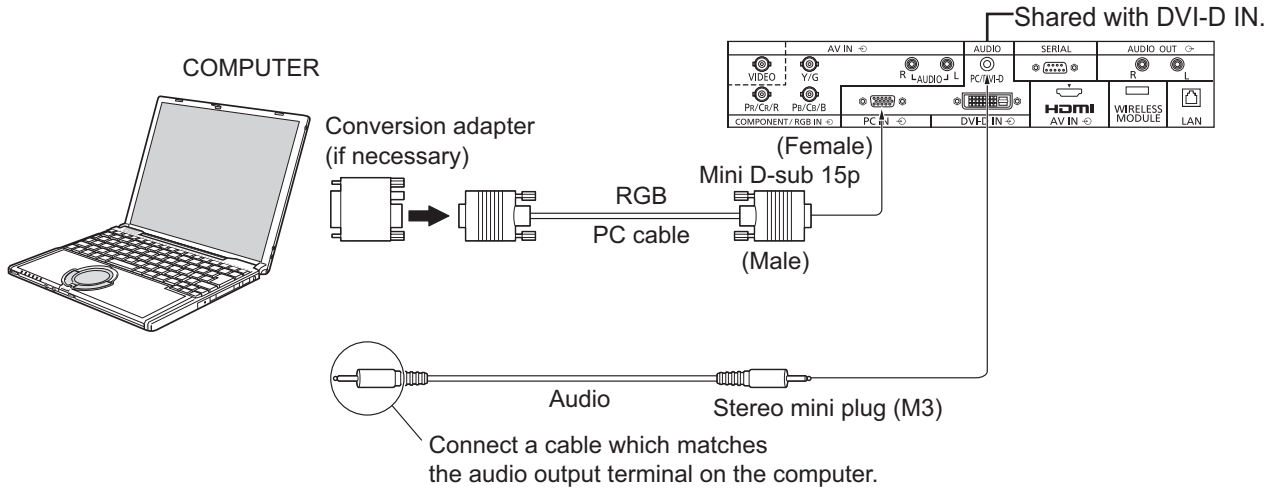

Notes:

- With regard to the typical PC input signals that are described in the applicable input signals list (see page 61), adjustment values such as for the standard picture positions and sizes have already been stored in this unit. You can add up to eight PC input signal types that are not included in the list.
- Computer signals which can be input are those with a horizontal scanning frequency of 15 to 110 kHz and vertical scanning frequency of 48 to 120 Hz. (However, the image will not be displayed properly if the signals exceed 1,200 lines.)
- The display resolution is a maximum of 1,440 × 1,080 dots when the aspect mode is set to “4:3”, and 1,920 × 1,080 dots when the aspect mode is set to “16:9”. If the display resolution exceeds these maximums, it may not be possible to show fine detail with sufficient clarity.
- The PC input terminals are DDC2B-compatible. If the computer being connected is not DDC2B-compatible, you will need to make setting changes to the computer at the time of connection.
- Some PC models cannot be connected to the set.
- There is no need to use an adapter for computers with DOS/V compatible Mini D-sub 15P terminal.
- The computer shown in the illustration is for example purposes only.
- Additional equipment and cables shown are not supplied with this set.
- Do not set the horizontal and vertical scanning frequencies for PC signals which are above or below the specified frequency range.
- Component Input is possible with the pin 1, 2, 3 of the Mini D-sub 15P Connector.
- Change the “Component/RGB-in select” setting in the “Setup” menu to “Component” (when Component signal connection) or “RGB” (when RGB signal connection). (see page 48)

Signal Names for Mini D-sub 15P Connector

Pin No.	Signal Name	Pin No.	Signal Name	Pin No.	Signal Name
①	R (P _R /C _R)	⑥	GND (Ground)	⑪	NC (not connected)
②	G (Y)	⑦	GND (Ground)	⑫	SDA
③	B (P _B /C _B)	⑧	GND (Ground)	⑬	HD/SYNC
④	NC (not connected)	⑨	+5 V DC	⑭	VD
⑤	GND (Ground)	⑩	GND (Ground)	⑮	SCL

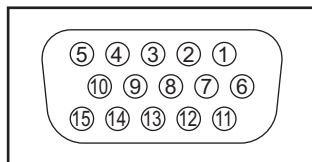

Pin Layout for PC Input Terminal

SERIAL Terminals connection

The SERIAL terminal is used when the Plasma Display is controlled by a computer.

Note: To use serial control for this unit, make sure to set the "Control I/F Select" in the "Network Setup" menu to "RS-232C". (refer to "Operating Instructions, Network Operations")

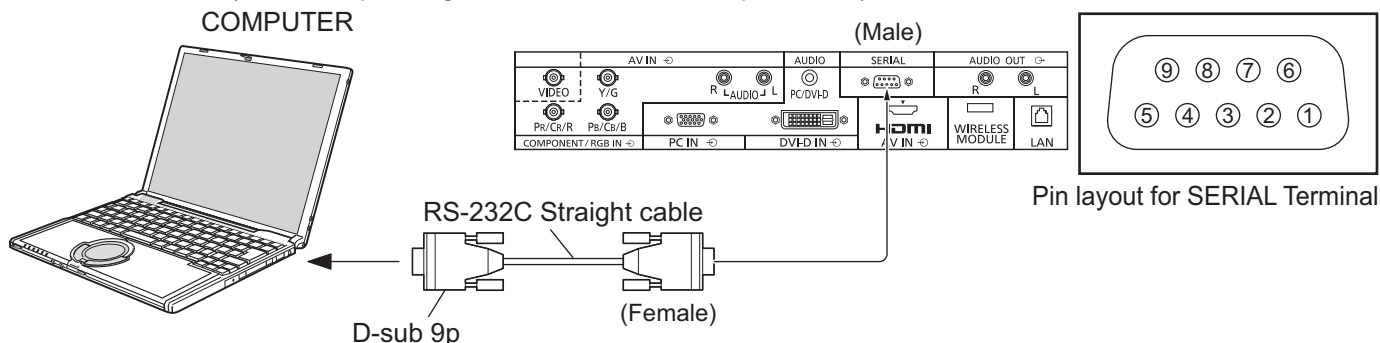

Notes:

- Use the RS-232C straight cable to connect the computer to the Plasma Display.
- The computer shown is for example purposes only.
- Additional equipment and cables shown are not supplied with this set.

The SERIAL terminal conforms to the RS-232C interface specification, so that the Plasma Display can be controlled by a computer which is connected to this terminal.

The computer will require software which allows the sending and receiving of control data which satisfies the conditions given below. Use a computer application such as programming language software. Refer to the documentation for the computer application for details.

Signal names for D-sub 9P connector

Pin No.	Details
②	R X D
③	T X D
⑤	GND
④ • ⑥	Non use
⑦ ⑧	(Shorted in this set)
① • ⑨	NC

These signal names are those of computer specifications.

Communication parameters

Signal level	RS-232C compliant
Synchronization method	Asynchronous
Baud rate	9600 bps
Parity	None
Character length	8 bits
Stop bit	1 bit
Flow control	-

Basic format for control data

The transmission of control data from the computer starts with a STX signal, followed by the command, the parameters, and lastly an ETX signal in that order. If there are no parameters, then the parameter signal does not need to be sent.

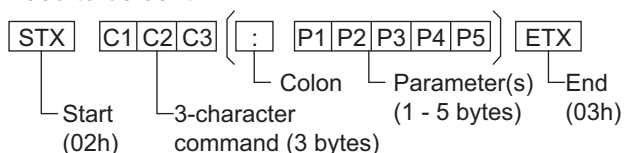

Notes:

- If multiple commands are transmitted, be sure to wait for the response for the first command to come from this unit before sending the next command.
- If an incorrect command is sent by mistake, this unit will send an "ER401" command back to the computer.
- S1A and S1B of Command IMS are available only when a dual input terminal board is attached.
- Consult your local Panasonic dealer for detail instructions on command usage.

Command

Command	Parameter	Control details
PON	None	Power ON
POF	None	Power OFF
AVL	**	Volume 00 - 63
AMT	0	Audio MUTE OFF
	1	Audio MUTE ON
IMS	None	Input select (toggle)
	SL1	SLOT input (SLOT INPUT)
	S1A	SLOT input (SLOT INPUT A)
	S1B	SLOT input (SLOT INPUT B)
	VD1	VIDEO input (VIDEO)
	YP1	COMPONENT/RGB IN input (COMPONENT)
	HM1	HDMI input (HDMI)
	DV1	DVI-D IN input (DVI)
	PC1	PC IN input (PC)
	NW1	Network input (NETWORK)
DAM	None	Screen mode select (toggle)
	ZOOM	Zoom, Zoom1
	FULL	16:9
	JUST	Just, Just1 (For Video/SD/HD signal)
	NORM	4:3, 4:3 (1)
	ZOM2	Zoom2 (For Video/SD/HD signal)
	ZOM3	Zoom3 (For Video/SD/HD signal)
	SJST	Just2 (For HD signal)
	SNOM	4:3 (2) (For HD signal)
	SFUL	4:3 Full (For HD signal)
	14:9	14:9 (For Video/SD/HD signal)

With the power off, this display responds to PON command only.

Power On / Off

Connecting the AC cord plug to the Plasma Display.

Fix the AC cord plug securely to the Plasma Display with the clammer. (see page 9)

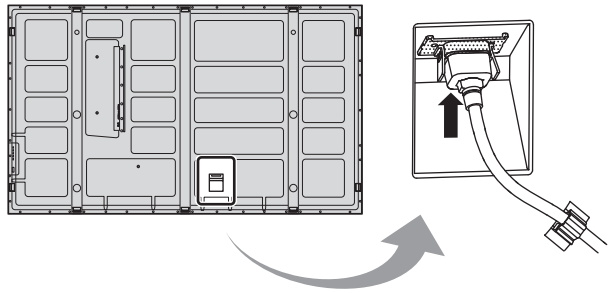

Connecting the plug to the Wall Outlet

Notes:

- Main plug types vary between countries. The power plug shown at right may, therefore, not be the type fitted to your set.
- When disconnecting the AC cord, be absolutely sure to disconnect the AC cord plug at the socket outlet first.

Press the Power switch on the Plasma Display to turn the set on: Power-On.

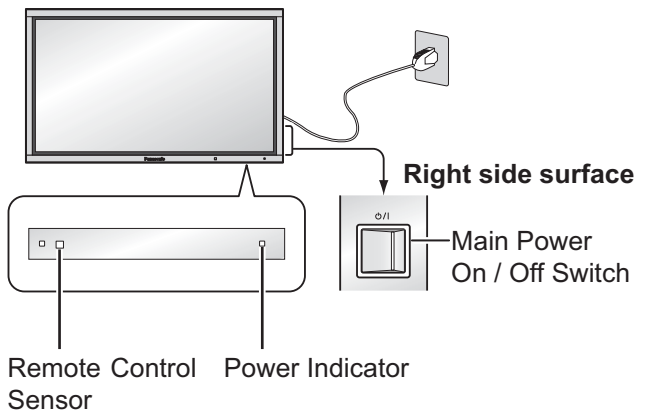

Power Indicator: Green

[Starting up the network]

It takes some time for the network to start up just after the power is turned on.

During that time, "Network Setup" in the "Setup" menu is grayed out and cannot be set.



Press the  button on the remote control to turn the Plasma Display off.

Power Indicator: Red (standby)

Press the  button on the remote control to turn the Plasma Display on.

Power Indicator: Green

Turn the power to the Plasma Display off by pressing the  switch on the unit, when the Plasma Display is on or in standby mode.

Note:

During operation of the power management function, the power indicator turns orange in the power off state.

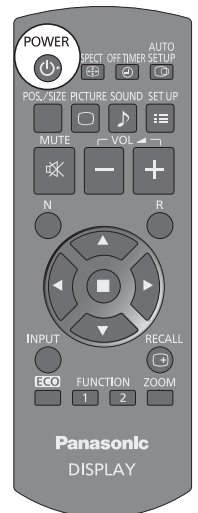

When first switching on the unit

Following screen will be displayed when the unit is turned on for the first time.
Select the items with the remote control. Unit buttons are invalid.

OSD Language

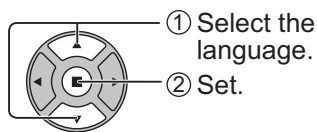

Day/Time Setup

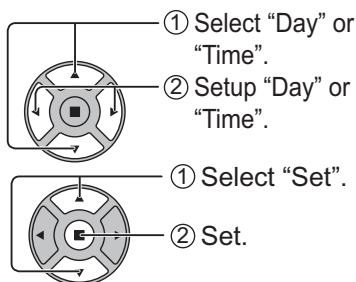
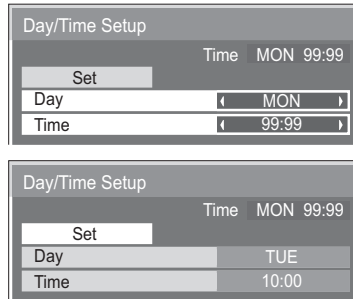

Display orientation

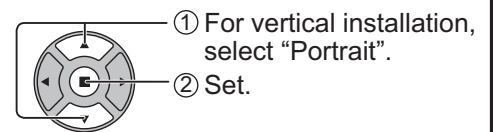
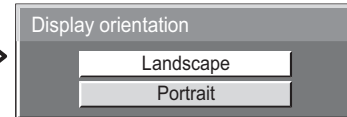

Notes:

- Once the items are set, the screens won't be displayed when switching on the unit next time.
- After the setting, the items can be changed in the following menus.
OSD Language (see page 43)
Day/Time Setup (see page 33)
Display orientation (see page 43)

Power ON warning message

The following message may be displayed when turning the unit power ON:

No activity power off Precautions



If "No activity power off" in Setup menu is set to "Enable", a warning message is displayed every time the power is turned ON. (see page 43)

This message display can be set with the following menu: Options menu

Power On Message (see page 54)

Selecting the input signal

INPUT



Press to select the input signal to be played back from the equipment which has been connected to the Plasma Display.

Input signals will change as follows:

→ PC → NETWORK → VIDEO → COMPONENT* → HDMI → DVI →

PC: PC input terminal in PC IN.

NETWORK: Network input terminal in LAN or WIRELESS MODULE.

VIDEO: Video input terminal in AV IN (VIDEO).

COMPONENT*: Component or RGB input terminal in COMPONENT/RGB IN.

HDMI: HDMI input terminal in AV IN (HDMI).

DVI: DVI input terminal in DVI-D IN.

* "COMPONENT" may be displayed as "RGB" depending on the setting of "Component/RGB-in select". (see page 48)

When an optional Terminal Board is installed:

→ PC → NETWORK → SLOT INPUT → VIDEO → COMPONENT → HDMI → DVI →

SLOT INPUT: Input terminal in Terminal Board

Note:

When a Terminal Board incompatible with the Plasma Display is installed, "Non-Compatible Function Board" is displayed.

When a Terminal Board with dual input terminals is installed:

→ PC → NETWORK → SLOT INPUT A → SLOT INPUT B → VIDEO → COMPONENT → HDMI → DVI →

SLOT INPUT A, SLOT INPUT B: Dual input terminal in Terminal Board.

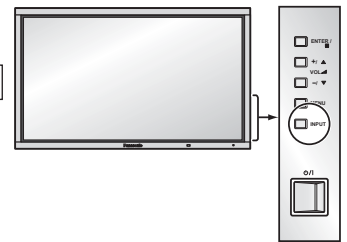

Notes:

- Selecting is also possible by pressing the INPUT button on the unit.
- Outputs the sound as set in "Audio input select" in the Options menu. (see page 57)
- Select to match the signals from the source connected to the component/RGB input terminals. (see page 48)
- Image retention (image lag) may occur on the plasma display panel when a still picture is kept on the panel for an extended period. The function that darkens the screen slightly is activated to prevent image retention (see page 59), but this function is not the perfect solution to image retention.

Basic Controls

Main Unit

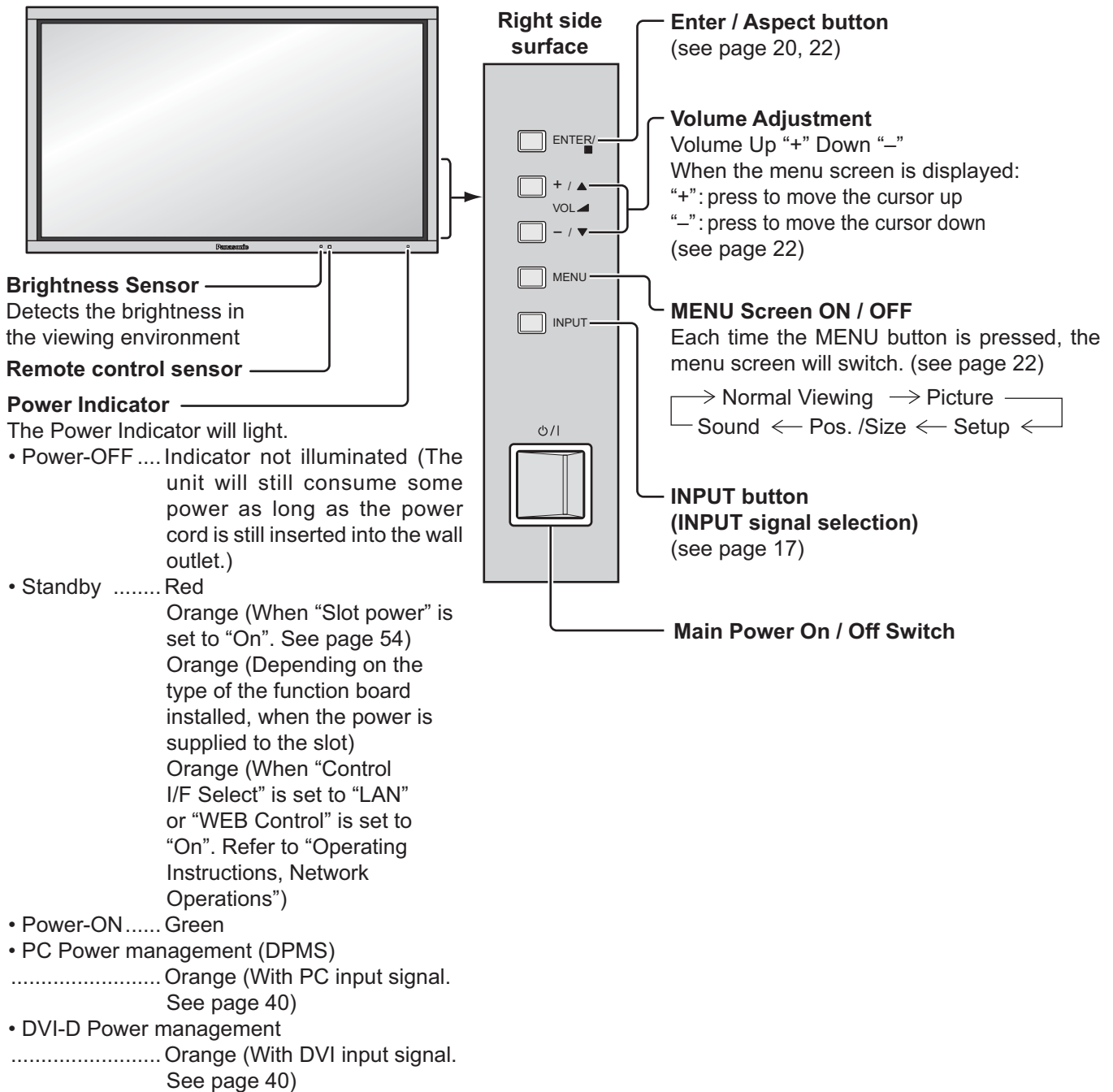

Remote Control Transmitter

ACTION button

Press to make selections.

ASPECT button

Press to adjust the aspect.
(see page 20)

Standby (ON / OFF) button

The Plasma Display must first be plugged into the wall outlet and turned on at the power switch (see page 15). Press this button to turn the Plasma Display On, from Standby mode. Press it again to turn the Plasma Display Off to Standby mode.

POS./SIZE button

(see page 23)

PICTURE button

(see page 26)

Sound mute On / Off

Press this button to mute the sound.
Press again to reactivate sound.
Sound is also reactivated when power is turned off or volume level is changed.

N button

(see page 25, 26, 27, 31)

POSITION buttons

INPUT button

Press to select Input signal sequentially. (see page 17)

ECO MODE (ECO)

Press to change the ECO MODE setup status. (see page 40)

FUNCTION buttons (FUNCTION)

(see page 42)

OFF TIMER button

The Plasma Display can be preset to switch to stand-by after a fixed period. The setting changes to 30 minutes, 60 minutes, 90 minutes and 0 minutes (off timer cancelled) each time the button is pressed.

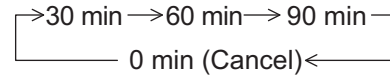

When three minutes remain, "Off timer 3 min" will flash.

The off timer is cancelled if a power interruption occurs.

AUTO SETUP button

Automatically adjusts the position/size of the screen. (see page 23)

SET UP button

(see page 32)

SOUND button

(see page 31)

Volume Adjustment

Press the Volume Up "+" or Down "-" button to increase or decrease the sound volume level.

R button

Press the R button to return to previous menu screen.

RECALL button

Press the "RECALL" button to display the current system status.

- ① Input label
- ② Aspect mode (see page 20)
Audio input (see page 57)
Profile name (see page 30)
NANODRIFT Saver operating (see page 38)
- ③ Touch Pen mode On/Off (see page 34)
- ④ Off timer
The off timer indicator is displayed only when the off timer has been set.
- ⑤ Clock display (see page 54)

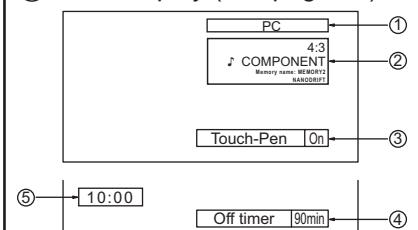

Digital Zoom

(see page 21)

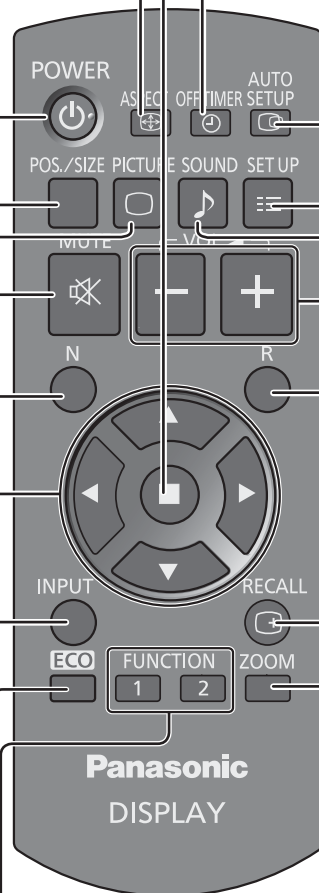

ASPECT Controls

The Plasma Display will allow you to enjoy viewing the picture at its maximum size, including wide screen cinema format picture.

Note:

Be aware that if you put the display in a public place for commercial purposes or a public showing and then use the aspect mode select function to shrink or expand the picture, you may be violating the copyright under copyright law. It is prohibited to show or alter the copyrighted materials of other people for commercial purposes without the prior permission of the copyright holder.



Press repeatedly to move through the aspect options:
For details about the aspect mode, please see "List of Aspect Modes" (page 60).

[from the unit]

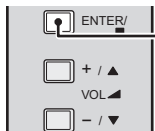

The aspect mode changes each time the ENTER button is pressed.

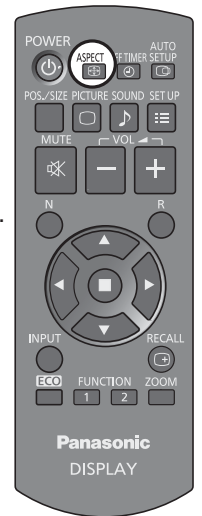

For VIDEO (S VIDEO) signal input:

→ 4:3 → Zoom1 → Zoom2 → Zoom3 → 16:9 → 14:9 → Just

For PC signal input:

→ 4:3 → Zoom → 16:9

For SD signal input (525 (480) / 60i • 60p, 625 (575) / 50i • 50p):

→ 4:3 → Zoom1 → Zoom2 → Zoom3 → 16:9 → 14:9 → Just

For HD signal input [1125 (1080) / 60i • 50i • 60p • 50p • 24p • 25p • 30p • 24sF, 1250 (1080) / 50i, 750 (720) / 60p • 50p]:

→ 4:3 → 4:3 Full → Zoom1 → Zoom2
Just ← 14:9 ← 16:9 ← Zoom3 ←

[For Touch Pen mode]

The aspect is fixed as "16:9" and you cannot switch.

Notes:

- The aspect mode is memorized separately for each input terminal.
- Do not allow the picture to be displayed in 4:3 mode for an extended period, as this can cause a permanent image retention to remain on the Plasma Display Panel.

All Aspect mode

Set "All Aspect" to "On" in Options menu to enable the extended aspect mode (page 54). When All Aspect mode, the aspect mode of pictures is switched as follows. For details about the aspect mode, please see "List of Aspect Modes". (page 60)

For VIDEO (S VIDEO) signal input:

→ 4:3 → Zoom1 → Zoom2 → Zoom3 → 16:9 → 14:9 → Just

For PC signal input:

→ 4:3 → Zoom → 16:9

For SD signal input (525 (480) / 60i • 60p, 625 (575) / 50i • 50p):

→ 4:3 → Zoom1 → Zoom2 → Zoom3 → 16:9 → 14:9 → Just

For HD signal input [1125 (1080) / 60i • 50i • 60p • 50p • 24p • 25p • 30p • 24sF, 1250 (1080) / 50i, 750 (720) / 60p • 50p]:

→ 4:3 Full → Zoom1 → Zoom2 → Zoom3 → 16:9 → 14:9 → Just1 → Just2 → 4:3 (1) → 4:3 (2)

Digital Zoom

This displays an enlargement of the designated part of the displayed image.

1 Display the operation guide.

ZOOM
 Press to access Digital Zoom.
 The operation guide will be displayed.

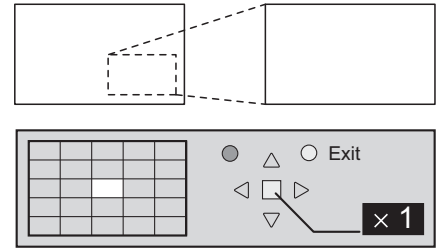

During Digital Zoom, only the following buttons can be operated.

[Remote control]

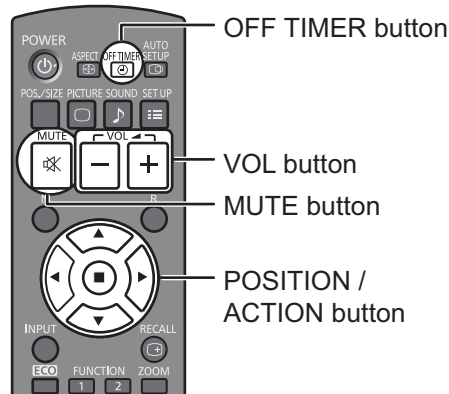

[Unit]

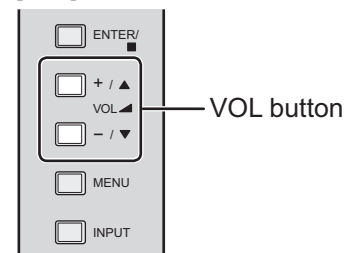

2 Select the area of the image to be enlarged.

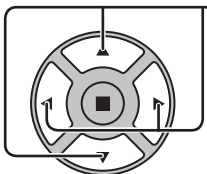
 Press on the enlargement location to select.
 The cursor will move.

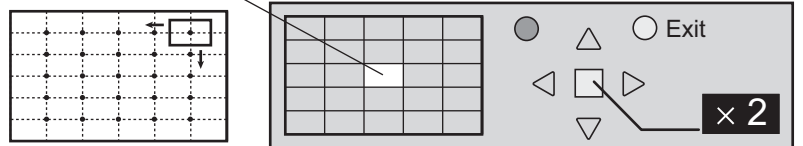

3 Select the magnification required for the enlarged display.

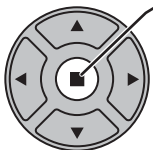
 Each time this is pressed, the magnification factor changes.
 This is shown in the image being displayed.



4 Return to normal display (quit Digital Zoom).

R
 Press to exit from the Digital Zoom.

Touch Pen mode during Digital Zoom

The electronic pen cannot be used while the image is enlarged with Digital Zoom during Touch Pen mode. The electronic pen can be used when Digital Zoom is cancelled.

Notes:

- When power goes OFF (including "Off Timer" operation), Digital Zoom terminates.
- The Digital Zoom function cannot be selected while in the following operation state:
 When MULTI DISPLAY Setup is On (see page 44).
 When Portrait Setup is On (see page 46).
 When Screensaver (except for Negative image) is running (see page 35)
- While Digital Zoom is in operation, "Adjusting Pos./Size" cannot be used.

On-Screen Menu Displays

Remote Control

Unit

1 Display the menu screen.

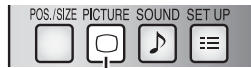

Press to select.
(Example: Picture menu)



Press several times.

Each time the MENU button is pressed, the menu screen will switch.

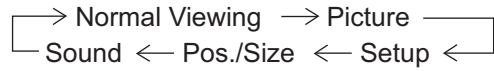

2 Select the item.

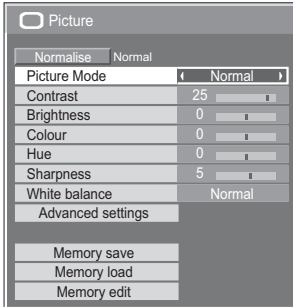

(Example: Picture menu)



Select.

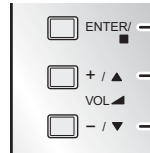

2 Press.

1 Select.

3 Set.



Set.

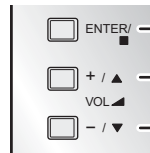

2 Press.

1 Set.

4 Exit the menu.



Press.
Press \odot to return to the previous menu.



Press several times.

Menu display list

Note: Menu that cannot be adjusted is grayout. Adjustable menu changes depending on signal, input and menu setting.

Picture menu

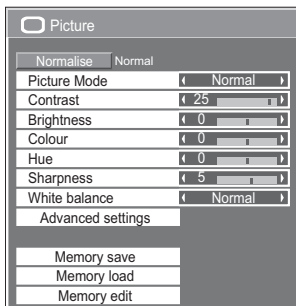

see page 26-30

Setup menu

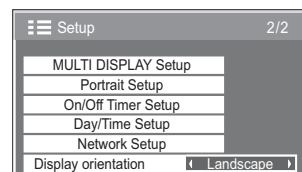
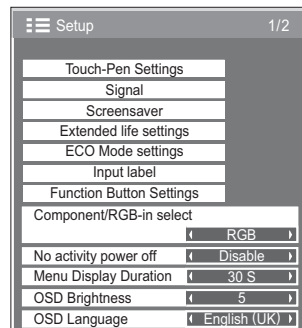

see page 32-51

Pos./Size menu

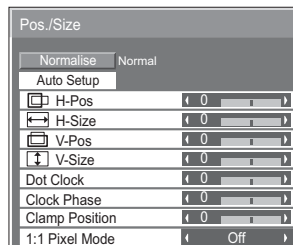

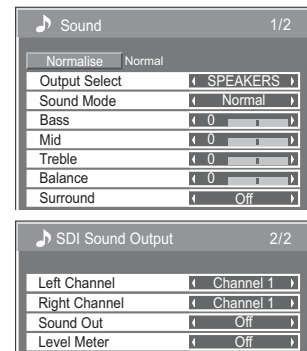

see page 23-25

Sound menu

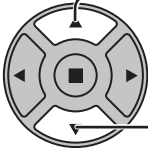
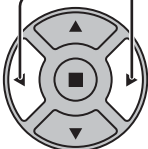

see page 31

Adjusting Pos./Size

- 1  Press to display the Pos./Size menu.
- 2  Press to select the menu to adjust.
- 3  Press to adjust the menu.
- 4  Press to exit from adjust mode.

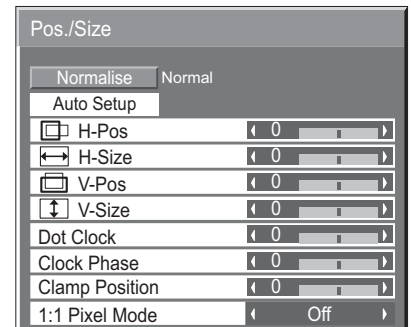

Note:

Unadjustable items are grayed out.

Adjustable items differ depending on the input signal and the display mode.

Notes:

- Adjustment details are memorized separately for different input signal formats (Adjustments for component signals are memorized for 525 (480) / 60i · 60p, 625 (575) / 50i · 50p, 1125 (1080) / 60i · 50i · 60p · 50p · 24p · 25p · 30p · 24sF, 1250 (1080) / 50i, 750 (720) / 60p · 50p each, and RGB/PC/Digital signals are memorized for each frequency.)
- If a “Cue” or “Rew” signal from a VCR or DVD player is received, the picture position will shift up or down. This picture position movement cannot be controlled by the Picture Pos./Size function.

Auto Setup When inputting a PC signal as an example, “H-Pos/V-Pos”, “H-Size/V-Size”, “Dot Clock” and “Clock Phase” are automatically corrected.

This setting is enabled under the following conditions:

- When inputting an analog signal (Component/PC):
This setting is enabled if “Component/RGB-in select” (see page 48) in Setup menu is “RGB”.
- When inputting a digital signal (HDMI/DVI):
A PC format signal enables this setting.

When the signal is not PC format, this setting is enabled only if “Over Scan” (see page 24) is “Off” or “1:1 Pixel Mode” (see page 25) is “On”. “H-Size/V-Size” is not automatically adjusted.

This setting will be invalid and will not work under the following conditions:

- When NETWORK input is selected.
- When VIDEO signal input
- During Multiple display, Portrait display or Digital Zoom.
- Aspect is set to “Just”
- “Display size” in the Options menu (see page 53) is set to “On”

Using Remote Control



When  on the remote control is pressed, “Auto Setup” will be executed.

When Auto Setup does not work, “Invalid” is displayed.

Auto mode

When the “Auto Setup” is set to “Auto” in the Options menu (see page 54), automatic position adjustment starts:

- When the display power is turned ON.
- When the input signal is switched.

Adjusting Pos./Size

Notes:

- If the dot clock frequency of an analog signal is 162 MHz or higher, “Dot Clock” and “Clock Phase” cannot be automatically corrected.
- When digital signal input, Dot Clock and Clock Phase cannot be made.
- Auto Setup may not work when a cropped or dark image is input. In such case, switch to a bright image with borders and other objects are clearly shown, and then try auto setup again.
- Depending on the signal, out of alignment may occur after Auto Setup. Carry out fine tuning for the position/size as required.
- If Auto Setup cannot set properly for vertical frequency 60Hz XGA signal (1024×768@60Hz, 1280×768@60Hz, and 1366×768@60Hz), pre-selecting the individual signal in “XGA Mode” (see page 49) may results in correct Auto Setup.
- Auto Setup does not work well when a signal such as additional information is superimposed out of valid image period or intervals between synchronizing and image signals are short, or for image signal with tri-level synchronizing signal added.
- If Auto Setup cannot adjust correctly, select “Normalise” once and press ACTION (■), then adjust Pos./Size manually.

H-Pos

Adjust the horizontal position.

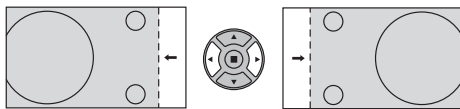

V-Pos

Adjust the vertical position.

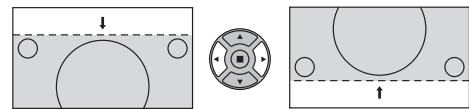

H-Size

Adjust the horizontal size.

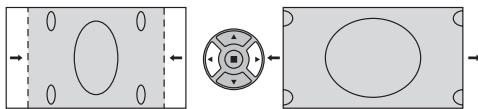

V-Size

Adjust the vertical size.

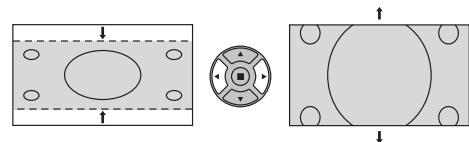

Dot Clock (During Component/PC input signal)

Periodic striped pattern interference (noise) may occur when a striped pattern is displayed. If this happens, adjust so that any such noise is minimized.

Clock Phase (During Component/PC input signal)

Eliminate the flickering and distortion.

Over scan Turn image over scan On/Off.

Configurable signals are as follows:

525i, 525p, 625i, 625p, 750/60p, 750/50p (Component Video, RGB, DVI, SDI, HDMI)

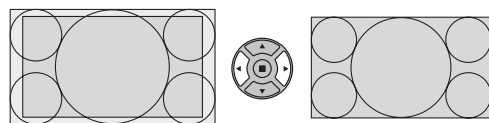

On

Off

Notes:

- When “Off” is set, “H-Size” and “V-Size” cannot be adjusted.
- When the “Display size” is set to “On” in the Options menu, this setting will be invalid. (see page 53)

Clamp Position (During Component/PC input signal)

Adjusts the clamp position when black parts of the image have no detail due to underexposure or are tinged with green.

Optimum value for Clamp Position adjustment

When black parts have no detail due to underexposure (blackout)

→ Value that causes least blackout is the optimum.

When black parts are tinged with green

→ Value that cancels the greenishness without causing blackout is the optimum.

1:1 Pixel Mode Adjusts the display size when 1125i, 1125p or 1250i signal is input.

Notes:

- Select On when you would like to replay 1920 × 1080 input signal.
- Applicable input signal;
1125 (1080) / 50i · 60i · 24sF · 24p · 25p · 30p · 50p · 60p, 1250 (1080) / 50i
- Select Off when flickering is shown around the image.
- H-Size and V-Size cannot be adjusted when On is selected.

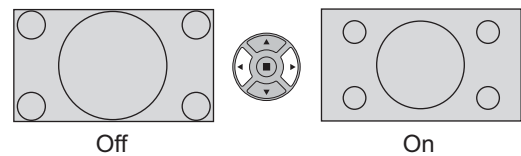

1:1 Pixel Mode (2k1k) When the input signal is a 2k1k signal (2048 × 1080 / 24p, 2048 × 1080 / 24sF), the display size is adjusted as follows. (For 2k1k signals)

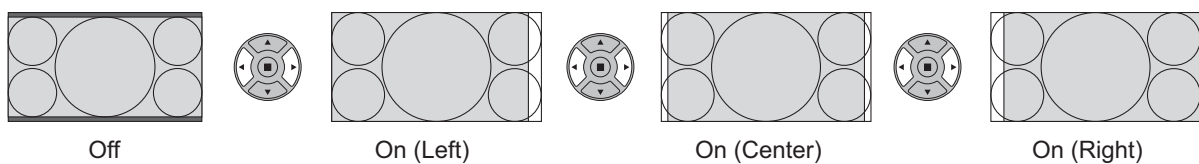

Note:

2k1k signals can only be received when the Dual Link HD-SDI Terminal Board (TY-FB11DHD) is installed.

Helpful Hint (/ Normalisation)

While the Pos./Size display is active, if either the N button on the remote control is pressed at any time or the ACTION () button is pressed during "Normalise", then all adjustment values are returned to the factory settings.

Picture Adjustments

1  Press to display the Picture menu.

2 Select to adjust each item.

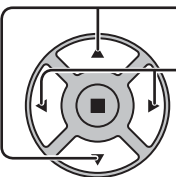
 Press to select the menu to adjust.
 Select the desired level by looking at the picture behind the menu.

Note:
 Menu that cannot be adjusted is grayout. Adjustable menu changes depending on signal, input and menu setting.

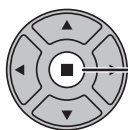
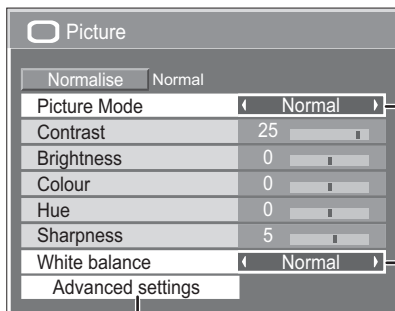

Press to enter Advanced settings.

Advanced settings
 Enables fine picture adjustment at a professional level (see next page).

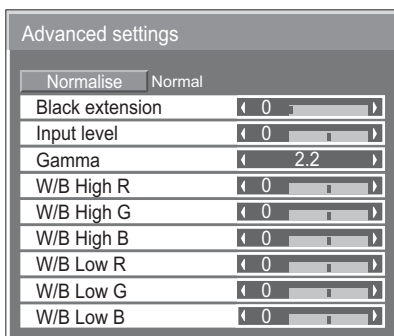

Press “◀” or “▶” button to switch between modes.

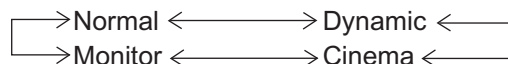

Normal

For viewing in standard (evening lighting) environments. This menu selects the normal levels of Brightness and Contrast.

Dynamic

For viewing in brighter environments. This menu selects higher than normal levels of Brightness and Contrast.

Cinema

For use in viewing tone-focused pictures with brightness reduced.

Monitor

For use when creating broadcast or movie content. With this picture, even if the overall average picture level (APL) changes, the brightness of areas with the same signal level does not change.

Picture Mode during Touch Pen mode

“Picture Mode” is fixed to “Normal” during Touch Pen mode.

Notes:

- When “Monitor” is selected in Picture Mode, the following menu items cannot be set.
 Extended life settings: Peak limit (see page 38)
 MULTI DISPLAY Setup menu: Video Wall Uniformity (see page 45)
 Portrait Setup menu: Video Wall Uniformity (see page 47)
- If you would like to change the picture and colour of the selected Picture menu to something else, adjust using the items in the Picture menu. (see next page)

Press “◀” or “▶” button to switch between modes.

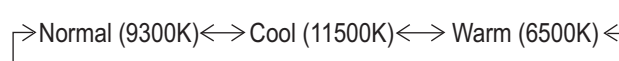

Helpful Hint ( /  **Normalisation**)

While the “Picture” menu is displayed, if either the N button on the remote control is pressed at any time or the ACTION () button is pressed during “Normalise”, then all adjustment values are returned to the factory settings.

Item	Effect	Adjustments
Contrast	Less More	Selects the proper brightness and density for the room.
Brightness	Darker Brighter	Adjusts for easier viewing of dark pictures such as night scenes and black hair.
Colour	Less More	Adjusts colour saturation.
Hue	Reddish Greenish	Adjusts for nice skin colour.
Sharpness	Less More	Adjusts picture sharpness.

Notes:

- You can change the level of each function (Contrast, Brightness, Colour, Hue, Sharpness) for each Picture Mode.
- The setting details for Normal, Dynamic, Cinema and Monitor respectively are memorized separately for each input terminal.
- In Contrast, there is not a noticeable change even when contrast is increased with a bright picture or reduced with a dark picture.

Advanced settings

Item	Effect	Details
Black extension	Less More	Adjusts the dark shades of the image in gradation.
Input level	Less More	Adjustment of parts which are extremely bright and hard to see.
Gamma	Down Up	2.0 ←→ 2.2 ←→ 2.4 ←→ 2.6
W/B High R	Less More	Adjusts the white balance for light red areas.
W/B High G	Less More	Adjusts the white balance for light green areas.
W/B High B	Less More	Adjusts the white balance for light blue areas.
W/B Low R	Less More	Adjusts the white balance for dark red areas.
W/B Low G	Less More	Adjusts the white balance for dark green areas.
W/B Low B	Less More	Adjusts the white balance for dark blue areas.

Notes:

- Carry out “W/B” adjustment as follows.
 1. Adjust the white balance of the bright sections using the “W/B High R”, “W/B High G” and “W/B High B” settings.
 2. Adjust the white balance of the dark sections using the “W/B Low R”, “W/B Low G” and “W/B Low B” settings.
 3. Repeat steps 1 and 2 to adjust.
 Steps 1 and 2 affect each other’s settings, so repeat each step in turn to make the adjustment.
- The adjustment values are memorized separately for each input terminal.
- The adjustment range values should be used as an adjustment reference.

Helpful Hint (/ **Normalise Normalisation)**

On the remote control unit, while the “Advanced settings” menu is displayed, if either the N button is pressed at any time or the ACTION () button is pressed during “Normalise”, then all adjustment values are returned to the factory settings.

Picture Profiles

Up to 8 combinations of picture adjustment values (in the Picture menu and Advanced settings) can be stored in the display memory as profiles and applied as needed, for a convenient way to enjoy your preferred picture settings.

Picture

Normalise	Normal
Picture Mode	Dynamic
Contrast	18
Brightness	0
Colour	0
Hue	0
Sharpness	3
White balance	Normal
Advanced settings	
Memory save	
Memory load	
Memory edit	

Save profiles (page 29)
Load profiles (page 30)
Edit profiles (page 30)



Picture

Normalise	Normal
Picture Mode	Normal
Contrast	25
Brightness	0
Colour	0
Hue	0
Sharpness	5
White balance	Normal
Advanced settings	

Save profiles ↓ Save the picture adjustment values in the MEMORY1 profile

Edit the profile ← Delete or rename the profile

MY PICTURE
MEMORY2
MEMORY3
MEMORY4
...
MEMORY8

MEMORY1
MEMORY2
MEMORY3
MEMORY4
...
MEMORY8

Load the profile ↓ Apply the MEMORY1 profile

Original picture



Picture

Normalise	Normal
Picture Mode	Normal
Contrast	0
Brightness	0
Colour	0
Hue	0
Sharpness	0
White balance	Normal
Advanced settings	

Custom picture



Picture

Normalise	Normal
Picture Mode	Normal
Contrast	25
Brightness	0
Colour	0
Hue	0
Sharpness	5
White balance	Normal
Advanced settings	

Saving profiles

Follow these steps to save picture adjustment values as profiles.

Note:

When the settings are locked in “Extended life settings”, profiles cannot be saved.

1 Specify the picture quality in the Picture menu and Advanced settings. (see page 26, 27)

2 In the Picture menu, select “Memory save”.



3 Select a profile name for saving the picture adjustment values.

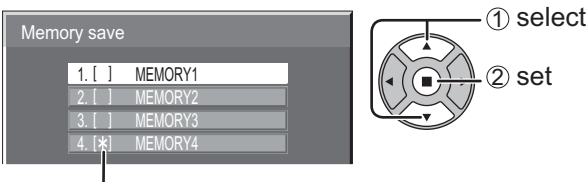

“*” appears for a profile in which the picture adjustments have already been saved.

4 Select “Ok”.

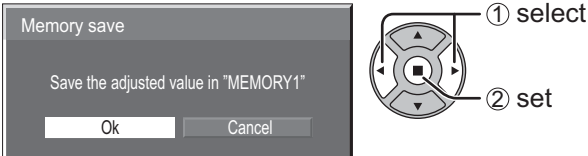

5 Enter a name for the profile.

[Entering profile names]

Profile names can be up to 40 characters.

To enter text, select characters in the on-screen keyboard.

Edit the default profile name in the text box as desired.

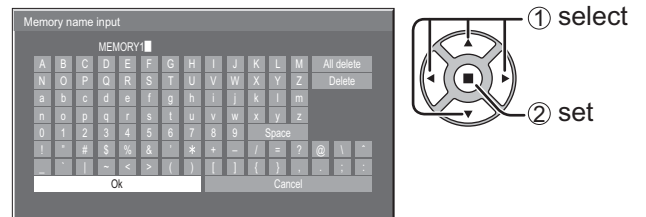

Example: Specifying “MY PICTURE”

① Select “All delete”.



All text is deleted.

To delete individual characters, select “Delete”.

② Select “M”.



Repeat this process to enter the next character.

③ Select “Y”.



④ Select “Space”.



6 When you finished entering the profile name, select “Ok”.

To cancel saving the profile, select “Cancel”.

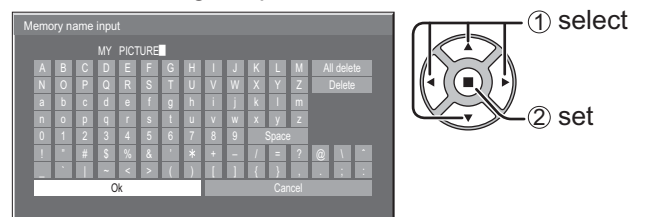

Loading profiles

Load profiles and apply the picture adjustment values to the display as follows.

Notes:

- Loaded profiles are stored in memory according to the selected input terminal. (see page 17)
- When the settings are locked in “Extended life settings”, profiles cannot be loaded.

1 In the Picture menu, select “Memory load”.



2 Select the profile to load.



When profile is being loaded, profile name is displayed.

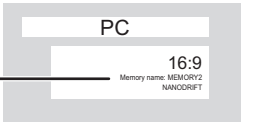

While in Touch Pen mode, a profile(s), whose “Picture Mode” is set to other than “Normal”, is grayed out and cannot be selected.

Editing profiles

Delete or rename profiles as follows.

<Deleting profiles>

1 In the Picture menu, select “Memory edit”.



2 Select “Memory delete”.



3 Select the profile to delete.
To delete all profiles, select “All delete”.

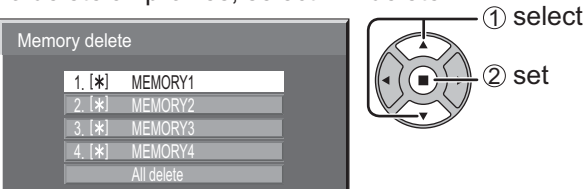

4 Select “Ok”.



<Renaming profiles>

1 In the Picture menu, select “Memory edit”.



2 Select “Memory name change”.



3 Select the profile to rename.



4 Enter a name for the profile.
Entering profile names → page 29

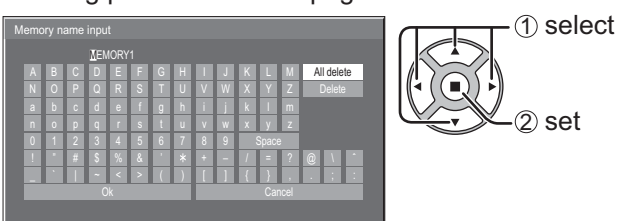

5 When you finished entering the profile name, select “Ok”.
To cancel renaming the profile, select “Cancel”.

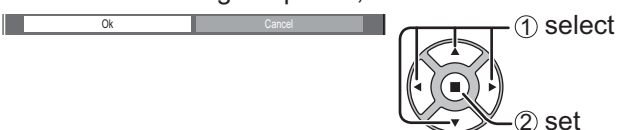

Sound Adjustment

1  Press to display the Sound menu.

2 Select to adjust each item.

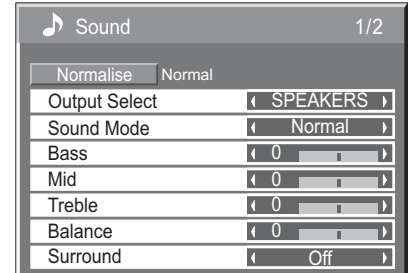
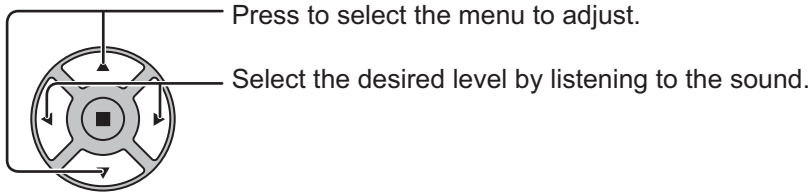

3  Press to exit from adjust mode.

Item	Details
Output Select	Select the audio output. SPEAKERS: Internal speakers AUDIO OUT: AUDIO OUT terminal output Notes: <ul style="list-style-type: none"> • If "AUDIO OUT" is selected, only "Balance" can be set. The other menus are grayed out and cannot be set. • The audio output options will be displayed when you adjust audio volume.  <ul style="list-style-type: none"> • Audio volume and "Balance" settings are memorized separately for each audio output.
Sound Mode	Normal: Emits the original sound. Dynamic: Accentuates sharp sound. Clear: Attenuates human voice.
Bass	Adjusts low pitch sounds.
Mid	Adjusts normal sounds.
Treble	Adjusts high pitch sounds.
Balance	Adjusts left and right volumes.
Surround	Select On or Off.

Note: Bass, Mid, Treble and Surround settings are memorized separately for each Sound Mode.

Helpful Hint (/ **Normalise** Normalisation)

While the "Sound" menu is displayed, if either the N button on the remote control is pressed at any time or the ACTION (■) button is pressed during "Normalise", then all adjustment values are returned to the factory settings.

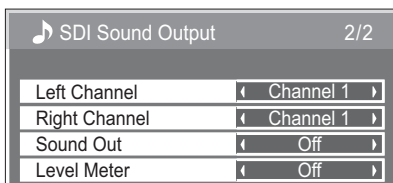

SDI Sound Output

This menu is available only when selecting a slot that any of the following terminal boards is installed:
 HD-SDI Terminal Board with audio (TY-FB10HD) or Dual Link HD-SDI Terminal Board (TY-FB11DHD)

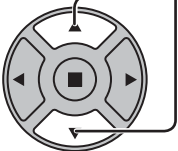
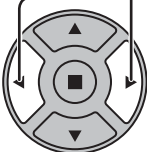

Item	Details
Left Channel	Channel 1 to Channel 16 Selects left audio channel.
Right Channel	Channel 1 to Channel 16 Selects right audio channel.
Sound Out	On ↔ Off On: Enables audio output. Off: Disables audio output.
Level Meter	Off ↔ 1-8ch ↔ 9-16ch Sets audio channels to show in the audio level meter. 8 channels are displayed in the audio level meter; 4 channels each on both right and left sides of the display. Off: Hides the audio level meter. 1-8ch: Displays the audio level meter (1-8ch) 9-16ch: Displays the audio level meter (9-16ch)

Setup menu

- 1  Press to display the Setup menu.
- 2  Press to select the menu to adjust.
- 3  Press to adjust the menu.
- 4  Press to exit from adjust mode.

Setup 1/2	
Touch-Pen Settings	
Signal	
Screensaver	
Extended life settings	
ECO Mode settings	
Input label	
Function Button Settings	
Component/RGB-in select	RGB
No activity power off	Disable
Menu Display Duration	30 S
OSD Brightness	5
OSD Language	English (UK)

Press  to return to the previous menu.

Setup menu screen

Setup 1/2	
Touch-Pen Settings	Page 34
Signal	Page 49
Screensaver	Page 35
Extended life settings	Page 37
ECO Mode settings	Page 40
Input label	Page 41
Function Button Settings	Page 42
Component/RGB-in select	
RGB	Page 48
No activity power off	Disable
Disable	Page 43
Menu Display Duration	30 S
30 S	Page 43
OSD Brightness	5
5	Page 43
OSD Language	English (UK)
English (UK)	Page 43

Setup 2/2	
MULTI DISPLAY Setup	Page 44
Portrait Setup	Page 46
On/Off Timer Setup	Page 33
Day/Time Setup	Page 33
Network Setup	
Display orientation	Page 43
Landscape	

Network Setup

Set this to connect the Display to a computer via a network. For details of PjLink and Network, refer to "Operating Instructions, Network Operations".

Day/Time Setup / On/Off Timer Setup

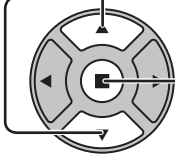
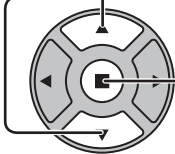

The timer can switch the Plasma Display On or Off.

Before attempting Timer Set, confirm the Time and adjust if necessary.
Then set POWER ON Time / POWER OFF Time.

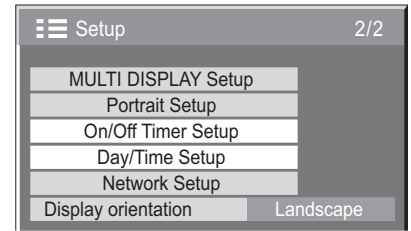
-  Press to display the Setup menu.
-  Press to select On/Off Timer Setup or Day/Time Setup.
 Press to display the On/Off Timer Setup screen or Day/Time Setup screen.

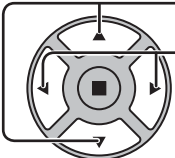
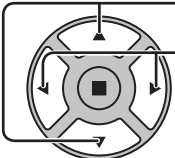

Day/Time Setup

-  Press to select Day or Time.
 Press to setup Day or Time.
 ▶ button: Forward
 ◀ button: Back
Notes:
 - Pressing “◀” or “▶” button once changes Time 1 minute.
 - Pressing “◀” or “▶” button continuously changes Time by 15 minutes.
-  Press to select Set.
 Press to store Day/Time Setup.

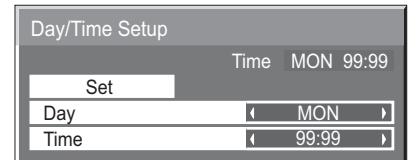

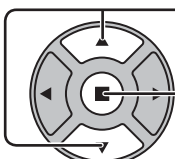
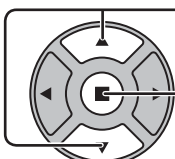
-  Press to select Set.
 Press to store Day/Time Setup.
- Notes:**
- Set cannot be selected unless Time is set.
 - Unless setting the present time other than “99:99”, “Day” and “Time” cannot be set.
 - The settings of “Day” and “Time” are reset when leaving the display turned off for about 7 days for the following reasons:
 Pressing ⏻/| switch of the unit to turn off the display.
 Disconnecting the AC cord.
 Interruption of power supply.

On/Off Timer Setup

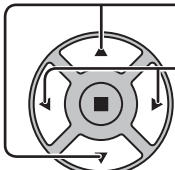
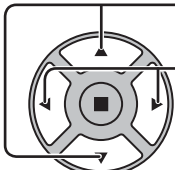
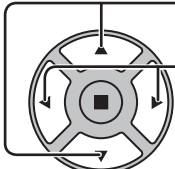
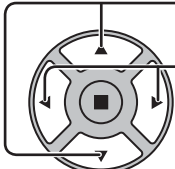
-  Press to select POWER ON Time / POWER OFF Time.
 Press to setup POWER ON Time / POWER OFF Time.
 ▶ button: Forward
 ◀ button: Back
Notes:
 - Pressing “◀” or “▶” button once changes POWER ON Time / POWER OFF Time 1 minute.
 - Pressing “◀” or “▶” button continuously changes POWER ON Time / POWER OFF Time by 15 minutes.
 -  Press to select POWER ON Function/POWER OFF Function.
 Press to select On.
- Note:** Timer function will not work unless “Time” is set.

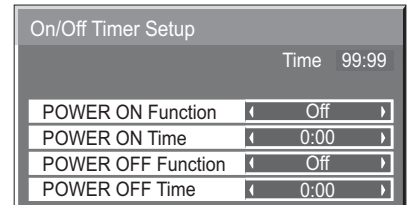

Touch-Pen Settings

Set Touch Pen mode.

Select "Touch-Pen Settings" in "Setup" menu and press  button.

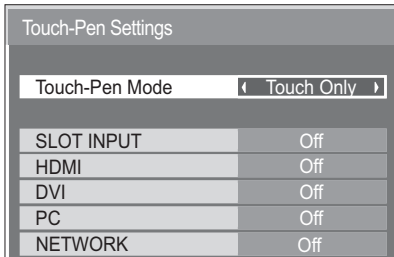

When a Terminal Board with dual input terminals is installed, "SLOT INPUT" is displayed as "SLOT INPUT A" and "SLOT INPUT B".

Touch-Pen Mode

Select an appropriate setting for the function of the electronic pen used.

Touch Only: Contact-type Touch Pen

Touch & Remote: Contact-type Touch Pen and remote pointer

SLOT INPUT – NETWORK

Set "On" or "Off" for each input terminal.

If you switch to the input terminal that is set to "On", the mode becomes Touch Pen mode.

"Touch-Pen: On" is displayed in Touch Pen mode.

Notes:

- When the following signal input, "Touch-Pen Settings" are disabled:
50i/50p/25p/24sF/24p signals and PC format signals with 50 Hz vertical frequency.
- The electronic pen cannot be used when VIDEO or COMPONENT input is selected.
- The electronic pen cannot be used during Digital Zoom. (see page 21)
- When using the electronic pen, adjust "Pos./Size" so that the screen of the computer can be correctly displayed. (see page 23)



Setting the Remote Control

You can also turn Touch Pen mode On/Off with the FUNCTION buttons on the remote control. (see page 42)

In Touch Pen mode, the menus and functions are restricted as follows.

Pos./Size menu		1:1 Pixel Mode: On Over scan: Off
Picture menu		Picture Mode: Fixed to "Normal" (see page 26)
Setup menu	Signal Extended life settings MULTI DISPLAY Setup Portrait Setup	FRAME CREATION: Off Picture Mode: Fixed to "Normal" (see page 37) MULTI DISPLAY Setup: Off Portrait Setup: Off
Options menu		Display size: Unavailable Rotate: Unavailable
ASPECT Controls		16:9

Screensaver (For preventing image retention)

Do not display a still picture, especially in 4:3 mode, for any length of time.
If the display must remain on, a Screensaver should be used.

1 Select "Screensaver" in "Setup" menu and press  button.

2 Function selection

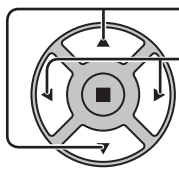

Press to select Function.

Press to select the desired function.

→ Negative image ↔ Scrolling bar only ←
→ White screen ↔ Overlay scrolling bar ←

Negative image : Negative image will be displayed on the screen.

Scrolling bar only : A white bar will scroll from left to right. The image won't be displayed.

Overlay scrolling bar : The brightness of the image will be decreased and a white bar will scroll on it.

White screen : The whole screen will be white.

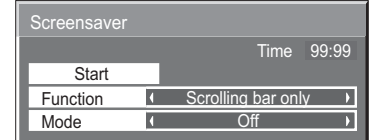

3 Mode selection

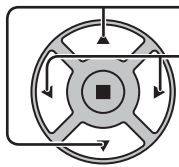

Press to select Mode.

Press to select each mode items.

→ Off
↕
Interval : Operates when Periodic Time and Operating Time are setup and those times arrive.
↕
Time Designation : Operates when Start Time and Finish Time are setup and those times arrive.
↕
Standby after SCR Saver: Operates while Screensaver duration, and display enters standby mode.
↕
→ On : Operates when Start is selected and the ACTION () button is pressed.

4 Start setting

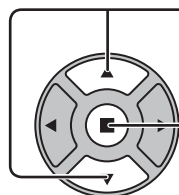

When the Mode is set to On, press to select Start.

Press to start Screensaver.

The menu screen will disappear and the Screensaver will be activated. **To stop the Screensaver under On, press the R button or any buttons on the main unit.**

Note: When the display is turned off, the Screensaver will be deactivated.

Setup of Screensaver Time

After selecting Time Designation, Interval or Standby after SCR Saver, the relevant Time Setup will become available for selection and the Operating Time may be set. (Time cannot be set when "Mode" is "On" or "Off".)

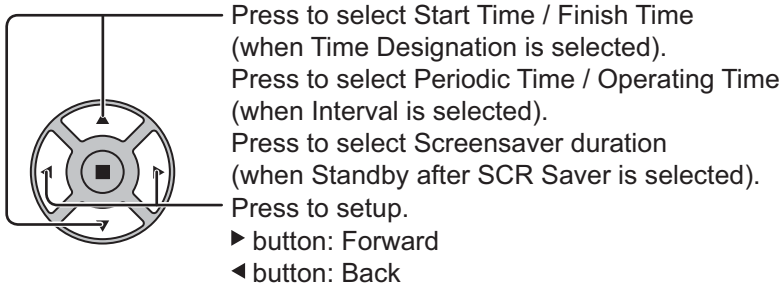

Screensaver		Time 15:00
Start		
Function	Scrolling bar only	
Mode	Time Designation	
Start Time	◀	6:15 ▶
Finish Time	◀	12:30 ▶

Screensaver		Time 15:00
Start		
Function	Scrolling bar only	
Mode	Interval	
Periodic Time	◀	12:00 ▶
Operating Time	◀	3:00 ▶

Screensaver		Time 15:00
Start		
Function	Scrolling bar only	
Mode	Standby after SCR Saver	
Screensaver duration	◀	6:15 ▶

Notes:

- Pressing "◀" or "▶" button once changes the Time 1 minute.
[However, switching occurs every 15 minutes when Periodic Time is selected.]
- Pressing "◀" or "▶" button continuously changes the Time by 15 minutes.
- "Screensaver duration" of the "Standby after SCR Saver" can be set from 0:00 to 23:59. When this is set to "0:00", "Standby after SCR Saver" will not be activated.

Note: Timer function will not work unless "Time" is set.

Reduces screen image retention

Extended life settings

The following settings are setup to reduce image retention:

Select "Extended life settings" in "Setup" menu and press  button.

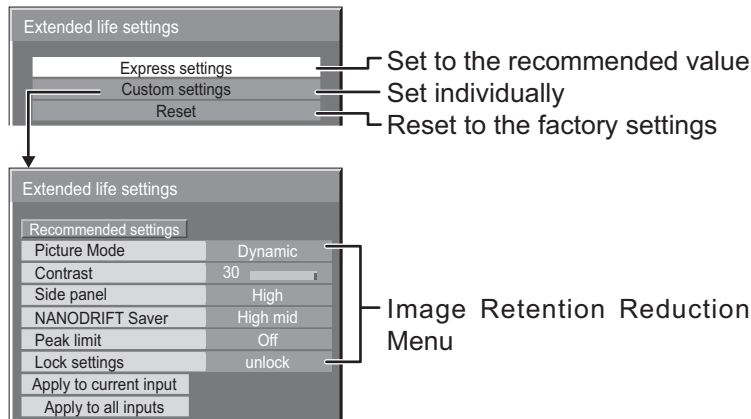

Image Retention Reduction Menu

"Extended life settings" enables you to set the following 5 menus (Image Retention Reduction Menu) as recommended values or set them individually.

Picture Mode

Contrast

"Picture Mode" and "Contrast" are same as "Picture" menu items (see page 26). The settings of this menu will be reflected to the "Picture" menu.

Note:

In "Extended life settings", "Picture Mode" and "Contrast" of the input with Touch Pen mode On cannot be changed. You can set "Contrast" in the "Picture" menu.

Side panel

Do not display a picture in 4:3 mode for an extended period, as this can cause an image retention to remain on the side panels on either side of the display field.

To reduce the risk of such an image retention, illuminate the side panels.

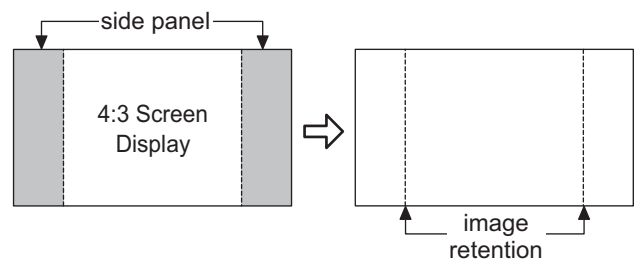

This function may be applicable to the non-picture area.

- Off:** Darken both ends.
- Low:** Make it dark gray.
- Mid:** Make it gray.
- High:** Make it light gray.

Notes:

- To reduce the occurrence of image retention, set the Side panel to High.
- The side panel may flash (alternate black/white) depending on the picture being shown on the screen. Using Cinema mode will reduce such flashing.

Reduces screen image retention

NANODRIFT Saver

Moves the display position of the screen slightly to reduce image retention on the display panel.

Low-High: NANODRIFT Saver operates. The display position of the screen moves at set time intervals. You can set the screen movement range. Some of the screen may appear to be missing as a result of this operation. If you change the value, a mask is displayed in the range where the picture is missing as a result of position movement.



When "NANODRIFT" Image Retention Reduction is operating, "NANODRIFT" is displayed.

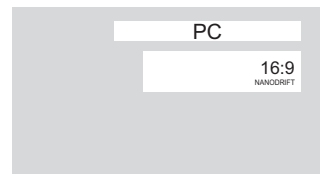

Note:

This function does not work in the following cases.

- When "MULTI DISPLAY Setup" is set to "On"
- When "PORTRAIT Setup" is set to "On"
- When in digital zoom mode

Peak limit

On: Suppresses image contrast (peak brightness).

Note: When a still picture is viewed for an extended time, the screen may become slightly darker. (see page 59)

Express settings

Set the "Image Retention Reduction" menu to the recommended settings.

All menus will be locked.

Picture Mode: Normal

Contrast: Recommended setting for each model

Side panel: High

NANODRIFT Saver: High mid

Peak limit: On

1 Select "Express settings".

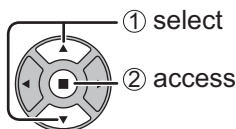
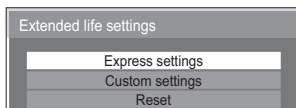

2 Select the input to apply the settings.

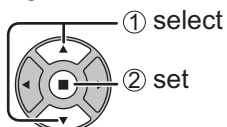
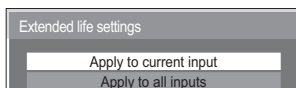

3 Select "Yes".

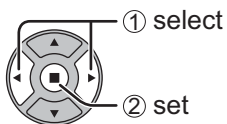
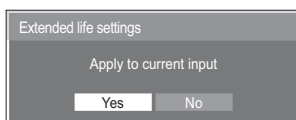

Custom settings

Set the individual “Image Retention Reduction” menu.

1 Select “Custom settings”.

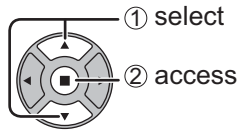
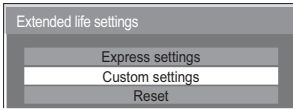

2 To set each menu to the recommended setting: Select “Recommended settings”.

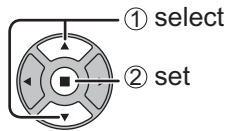
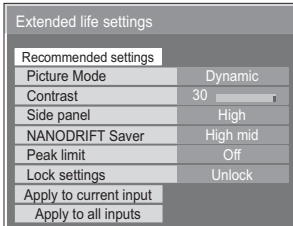

Each menu will be set as same as the “Express settings”.

3 Set each menu.

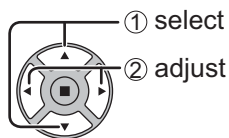
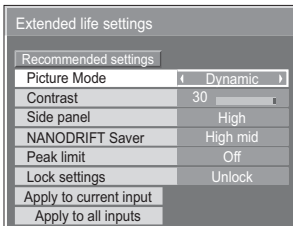

4 To lock each menu setting: Set the “Lock settings” to “Lock”.

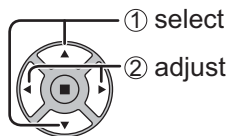
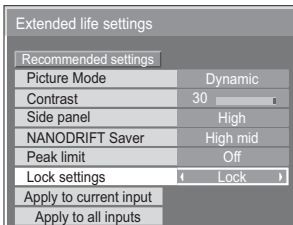

When a menu is locked, it is grayed out and cannot be set.

“Picture Mode” and “Contrast” will no longer be able to set in the “Picture” menu, and they are labeled with icon to indicate their locked status. Also, “Normalise”, “Memory save” and “Memory load” are not available.

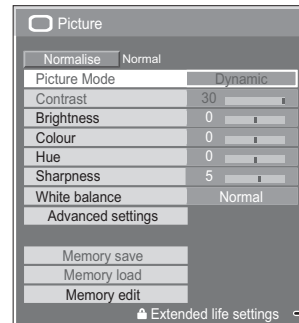

Touch Pen mode when a menu is locked

When a menu is locked, “Touch-Pen Settings” are disabled and Touch Pen mode cannot be set.

5 Select the input to apply the settings.

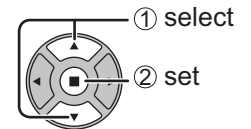
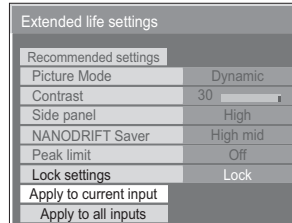

6 Select “Yes”.

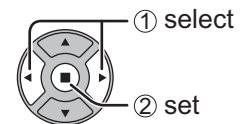
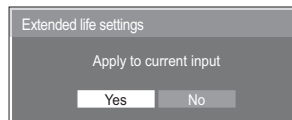

Reset

Reset the “Image Retention Reduction” menu to the factory settings. Each menu will be unlocked.

1 Select “Reset”.

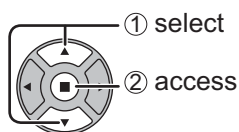
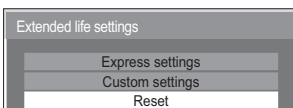

3 Select “Yes”.

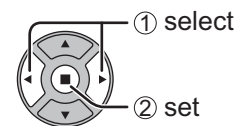
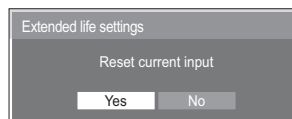

2 Select the input to reset the settings.

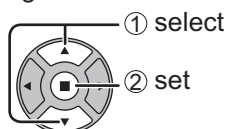
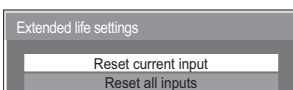

ECO Mode settings

Select "ECO Mode settings" in "Setup" menu and press  button.



ECO Mode settings	
ECO Mode	Custom
Power save	Off
Standby save	On
PC Power management	Off
DVI-D Power management	Off
No signal power off	Disable

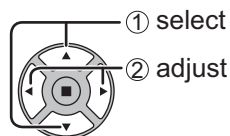

ECO Mode

Custom: The menu of power consumption reduction is individually set.

On: The following fixed values are set to the menu of power consumption reduction. Individual setting is not available.

Power save: On
Standby save: On
PC Power management: On
DVI-D Power management: On
No signal power off: Enable

Using Remote Control

When  is pressed, the "ECO Mode" setting changes.

ECO Mode On

Custom settings

The menu of the power consumption reduction is individually set. This setting is enabled when "ECO Mode" is set to "Custom".

Power save

When this function is turned On, luminous level of the Plasma Display is suppressed, so power consumption is reduced.

Sensor: The luminous level of the Plasma Display is automatically adjusted according to the viewing environment.

Note: In Touch Pen mode, the sensor function is disabled.

Standby save

When this function is turned On, power consumption of the microcomputer is reduced during power supply standby (see page 15, 18, 19), so standby power of the set is reduced.

PC Power management

When this function is set to On, it operates under the following conditions to turn the power on or off automatically. When no pictures (HD/VD sync signals) are detected for 30 or so seconds during PC signal input:

→ Power is turned off (standby); the power indicator lights up orange.

When pictures (HD/VD sync signals) are subsequently detected:

→ Power is turned on; the power indicator lights up green.

Notes:

- This function operates only during PC signal input.
- This function is effective when "Sync" is set to "Auto", "Component / RGB-in select" is set to "RGB" and during normal viewing.

DVI-D Power management

When this function is set to On, it operates under the following conditions to turn the power on or off automatically. When no pictures (sync signal) are detected for 30 or so seconds during DVI signal input:

→ Power is turned off (standby); the power indicator lights up orange.

When pictures (sync signal) are subsequently detected:

→ Power is turned on; the power indicator lights up green.

Notes:

- This function operates only during DVI signal input.
- This function is invalid during input from DVI-D Terminal Board (TY-FB11DD).
- Depending on the type of terminal board equipped, this function may be invalid.

No signal power off

Equipment power supply is turned Off when there is no signal.

When this is set to "Enable", the power supply of the unit goes Off 10 minutes after the input signals stop.

Customizing the Input labels

This function can change the label of the Input signal to be displayed. (see page 17)

Select "Input label" in "Setup" menu and press  button.

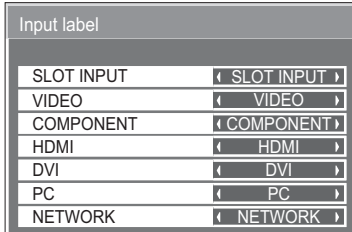

Image input	Input label
[SLOT INPUT]*1	SLOT INPUT / DVD1 / DVD2 / DVD3 / DVD4 / Blu-ray1 / Blu-ray2 / Blu-ray3 / Blu-ray4 / CATV / VCR / STB / (Skip)
[VIDEO]	VIDEO / DVD1 / DVD2 / DVD3 / DVD4 / Blu-ray1 / Blu-ray2 / Blu-ray3 / Blu-ray4 / CATV / VCR / STB / (Skip)
[COMPONENT]*2	COMPONENT / DVD1 / DVD2 / DVD3 / DVD4 / Blu-ray1 / Blu-ray2 / Blu-ray3 / Blu-ray4 / CATV / VCR / STB / (Skip)
[HDMI]	HDMI / DVD1 / DVD2 / DVD3 / DVD4 / Blu-ray1 / Blu-ray2 / Blu-ray3 / Blu-ray4 / CATV / VCR / STB / (Skip)
[DVI]	DVI / DVD1 / DVD2 / DVD3 / DVD4 / Blu-ray1 / Blu-ray2 / Blu-ray3 / Blu-ray4 / CATV / VCR / STB / (Skip)
[PC]	PC / DVD1 / DVD2 / DVD3 / DVD4 / Blu-ray1 / Blu-ray2 / Blu-ray3 / Blu-ray4 / CATV / VCR / STB / (Skip)
[NETWORK]	NETWORK / (Skip)

(Skip): The INPUT button press will skip its input.

*1 "SLOT INPUT" is displayed when a Terminal Board is installed.

*2 "COMPONENT" may be displayed as "RGB" depending on the setting of "Component/RGB-in select". (see page 48)

When a Terminal Board with dual input terminals is installed

"SLOT INPUT" is displayed as "SLOT INPUT A" and "SLOT INPUT B" and independent settings are available.



[SLOT INPUT A]	SLOT INPUT A / DVD1 / DVD2 / DVD3 / DVD4 / Blu-ray1 / Blu-ray2 / Blu-ray3 / Blu-ray4 / CATV / VCR / STB / (Skip)
[SLOT INPUT B]	SLOT INPUT B / DVD1 / DVD2 / DVD3 / DVD4 / Blu-ray1 / Blu-ray2 / Blu-ray3 / Blu-ray4 / CATV / VCR / STB / (Skip)

When a Terminal Board with fixed display (such as Tuner Board) is installed

Only fixed display and (Skip) are available as Input label of "SLOT INPUT".

[SLOT INPUT]	fixed display / (Skip)
--------------	--

Function Button Settings

Set the functions that operates when ^{FUNCTION}   is pressed.

Select "Function Button Settings" in "Setup" menu and press  button.

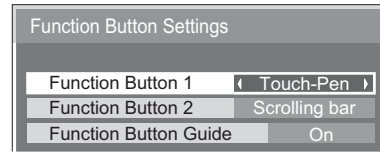

• Function Button 1, Function Button 2

The following functions are set to the FUNCTION button.

Note:

Factory settings are as follows.
FUNCTION1 button: Touch-Pen
FUNCTION2 button: Scrolling bar

ECO Mode settings / Signal / On/Off Timer Setup

The menu is displayed. (Example: ECO Mode settings)

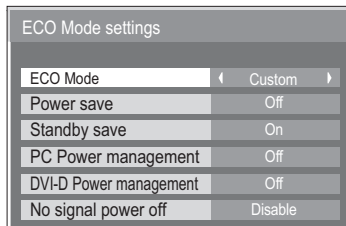

Pressing the FUNCTION button clears the menu.



Scrolling bar

Activates the "Scrolling bar only" screensaver. After 15 minutes, the display enters standby mode.



To exit this mode, press  button.

INPUT (SLOT)* - INPUT (NETWORK)

Simply press ^{FUNCTION}   to select the input.

* "INPUT (SLOT)" is displayed when an optional Terminal Board is installed.

When a Terminal Board with dual input terminals is installed, "INPUT (SLOT A)" and "INPUT (SLOT B)" are displayed.

Touch-Pen

Press ^{FUNCTION}   and turn Touch Pen mode On/Off.

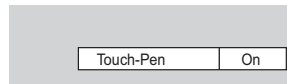

Network Setup

"Network Setup" menu is displayed.

Multi-Live

Switch to the Multi-Live mode when using the "Wireless Manager".

Computer Search

The list of connectable computers on the network is displayed.

Note:

For the network function, refer to "Operating Instructions, Network Operations" and the instruction manual of "Wireless Manager" in use.

AV Mute

Mutes the audio and video. To exit this mode, press any button.

• Function Button Guide

The function display setting for the FUNCTION button is configured.

On: Press the FUNCTION button to display the function list of the button.

Off: The function list is not displayed.

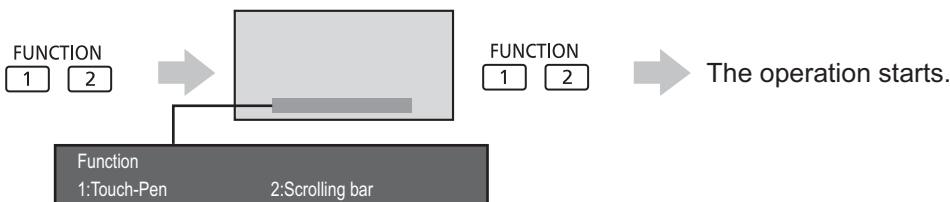

No activity power off

Disable ←→ **Enable**

When this function is set to “Enable”, the power is turned off (standby) automatically when there is no operation of the Plasma Display for 4 hours.

Starting from 3 minutes before the turn off, the remaining time will be displayed.

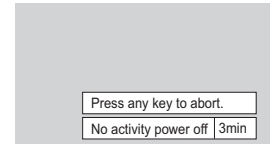

When the power is turned off due to this function, a message “Last turn off due to 'No activity power off'.” is displayed next time the power is turned on.

Note:

During the screensaver is running, this function is disabled.

Menu Display Duration / OSD Brightness

Set the display time and brightness of the on-screen menu display.

Menu Display Duration: 5 S - 30 S

OSD Brightness: 1 - 5

OSD Language

Select your preferred language.

■ Selectable languages

- English(UK)
- Deutsch
- Français
- Italiano
- Español
- ENGLISH(US)
- 中文.....(Chinese)
- 日本語.....(Japanese)
- Русский.....(Russian)

Display orientation

Sets the fan control, panel drive control, and the display style of on-screen menu for vertical installation.



Landscape

Fan control and panel drive control for horizontal installation.



Portrait

Fan control and panel drive control for vertical installation. On-screen menu will be rotated 90 degrees counterclockwise to be suitable for the setting.

Notes:

- If the display is installed vertically, the power switch should be located at the bottom.
- When you change this setting, fan control and panel drive control will be switched as the power is turned on next time.

Setup for MULTI DISPLAY

By lining up Plasma Displays in groups, for example, as illustrated below, an enlarged picture may be displayed across all screens.

For this mode of operation, each plasma display has to be set up with a Display number to determine its location.

Note:

During Touch Pen mode, "MULTI DISPLAY Setup" becomes "Off" and this function cannot be used.

(Example)

group of 4 (2 × 2) group of 9 (3 × 3) group of 16 (4 × 4) group of 25 (5 × 5)



How to Setup MULTI DISPLAY

1 Select "MULTI DISPLAY Setup" in "Setup" menu and press button.

2 Press to select the MULTI DISPLAY Setup.
Press to select "On" or "Off".

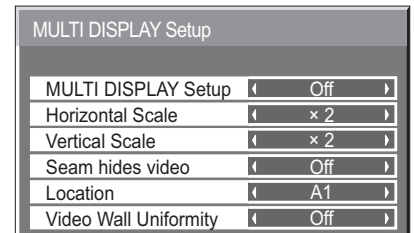

Item	Details																																																									
MULTI DISPLAY Setup	Select "On" or "Off". Note: If you set MULTI DISPLAY Setup to On, Portrait Setup will be unavailable.																																																									
Horizontal Scale	Select "× 1", "× 2", "× 3", "× 4", "× 5".																																																									
Vertical Scale	Select "× 1", "× 2", "× 3", "× 4", "× 5".																																																									
Seam hides video	Select "On" or "Off". To hide joints between displays. Suitable for moving image display. To show joints between displays. Suitable for still image display.																																																									
Location	Select the required arrangement number. (A1-E5 : Refer to the following) Display Number locations for each arrangement. (Examples) (2 × 1) (2 × 3) (4 × 2) (4 × 4) (5 × 5) <table style="display: inline-table; margin-right: 10px;"> <tr><td>A1</td><td>A2</td></tr> </table> <table style="display: inline-table; margin-right: 10px;"> <tr><td>A1</td><td>A2</td></tr> <tr><td>B1</td><td>B2</td></tr> <tr><td>C1</td><td>C2</td></tr> </table> <table style="display: inline-table; margin-right: 10px;"> <tr><td>A1</td><td>A2</td><td>A3</td><td>A4</td></tr> <tr><td>B1</td><td>B2</td><td>B3</td><td>B4</td></tr> </table> <table style="display: inline-table; margin-right: 10px;"> <tr><td>A1</td><td>A2</td><td>A3</td><td>A4</td></tr> <tr><td>B1</td><td>B2</td><td>B3</td><td>B4</td></tr> <tr><td>C1</td><td>C2</td><td>C3</td><td>C4</td></tr> <tr><td>D1</td><td>D2</td><td>D3</td><td>D4</td></tr> </table> <table style="display: inline-table;"> <tr><td>A1</td><td>A2</td><td>A3</td><td>A4</td><td>A5</td></tr> <tr><td>B1</td><td>B2</td><td>B3</td><td>B4</td><td>B5</td></tr> <tr><td>C1</td><td>C2</td><td>C3</td><td>C4</td><td>C5</td></tr> <tr><td>D1</td><td>D2</td><td>D3</td><td>D4</td><td>D5</td></tr> <tr><td>E1</td><td>E2</td><td>E3</td><td>E4</td><td>E5</td></tr> </table>	A1	A2	A1	A2	B1	B2	C1	C2	A1	A2	A3	A4	B1	B2	B3	B4	A1	A2	A3	A4	B1	B2	B3	B4	C1	C2	C3	C4	D1	D2	D3	D4	A1	A2	A3	A4	A5	B1	B2	B3	B4	B5	C1	C2	C3	C4	C5	D1	D2	D3	D4	D5	E1	E2	E3	E4	E5
A1	A2																																																									
A1	A2																																																									
B1	B2																																																									
C1	C2																																																									
A1	A2	A3	A4																																																							
B1	B2	B3	B4																																																							
A1	A2	A3	A4																																																							
B1	B2	B3	B4																																																							
C1	C2	C3	C4																																																							
D1	D2	D3	D4																																																							
A1	A2	A3	A4	A5																																																						
B1	B2	B3	B4	B5																																																						
C1	C2	C3	C4	C5																																																						
D1	D2	D3	D4	D5																																																						
E1	E2	E3	E4	E5																																																						

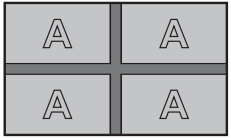
Item	Details
Video Wall Uniformity	<p>Reduces the peak of brightness for each display to enable as uniform display as possible. Select "Off" or "On".</p> <p>The brightness depends on each display's setting.</p>  <p>The brightness difference is minimized.</p>  <p>Off</p> <p>On</p> <p>Note: If you set Video Wall Uniformity to On, the following menus will be unavailable and these settings will be fixed to the initial values. Picture menu: Colour, Hue, Input level (Advanced settings)</p>









ID Remote Control Function

You can set the remote control ID when you want to use this remote control on one of several different displays.

Note:

To operate this function, please purchase ID remote controller sold separately.

Object model : EUR7636090R

- 1 Switch  to  on the right side.
- 2 Press the  button on the remote control.
- 3 Press one of  - ,  for the tens digit setting.
- 4 Press one of  - ,  for the units digit setting.

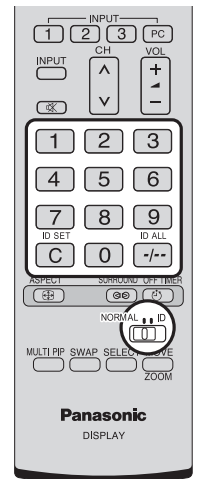

Notes:

- The numbers in 2, 3 and 4 should be set up quickly.
- Adjustable ID number range is 0 - 99.
- If a number button is pressed more than two times, the first two numbers become the ID number for the remote control.

ID remote control button operation

The operation is the same as normal remote control except for the  button.

ID Cancellation

Press  button on remote control. (This has the same effect as pressing the , ,  buttons at the same time.)

Notes:

- Set the Remote ID "On" to operate the ID remote control.
If Remote ID is set to "On", you can use the remote control without identical ID number during option menu display. (see page 53)
- The ID remote control cannot be used when ID select is set to anything other than 0, and the remote control ID is not the same as the ID select number (see page 53).

Setup for Portrait

Divide an input image into 3 parts, and display one of them to a plasma display which is set vertically. The image will be enlarged 3 times and rotated 90-degree.

(Example)

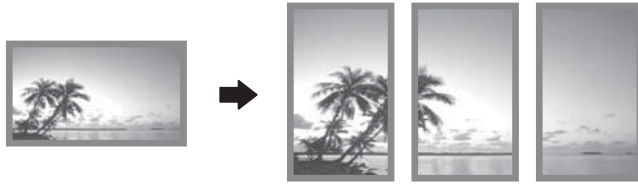

Notes:

- During Touch Pen mode, "Portrait Setup" becomes "Off" and this function cannot be used.
- When using the Portrait function with displays set vertically, "Display orientation" in Setup menu has to be set to "Portrait" (see page 43).
- Turn down the power switch for the downward direction when you set Display vertically.

How to setup Portrait

1 Select "Portrait Setup" in "Setup" menu and press button.

2 Press to select the Portrait Setup.

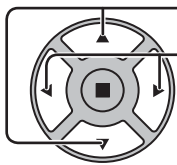

Press to select "On" or "Off".

Note:

If you set Portrait Setup to On, MULTI DISPLAY Setup will be unavailable.

Portrait Setup	
Portrait Setup	Off
Seam hides video	Off
Viewing Area	16 : 9
Location	1
Video Wall Uniformity	Off

3 Press to select Seam hides video.

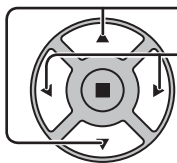

Press to select "Off", "On".

Portrait Setup	
Portrait Setup	Off
Seam hides video	Off
Viewing Area	16 : 9
Location	1
Video Wall Uniformity	Off

To hide joints between displays.	To show joints between displays.
<p>Example</p>	<p>Example</p>
Suitable for moving image display.	Suitable for still image display.
On	Off

4 Viewing Area / Location

Viewing Area: Set a mode of image division for Portrait function.

Location: Set a location of image to be displayed for Portrait function.

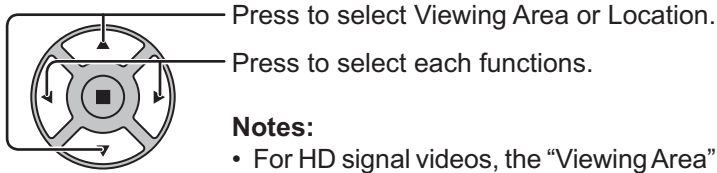

Notes:

- For HD signal videos, the “Viewing Area” is set at “16:9”, and cannot be changed.
HD signal: 1125(1080) / 60i • 50i • 60p • 50p • 24p • 25p • 30p • 24sF, 750(720) / 60p • 50p, 1250(1080) / 50i
- When “Viewing Area” is “16:9”, the aspect mode is set to “16:9”.

Portrait Setup	
Portrait Setup	Off
Seam hides video	Off
Viewing Area	16 : 9
Location	1
Video Wall Uniformity	Off

Location setting

When Portrait Setup is “On”:

Display the image of the selected location.

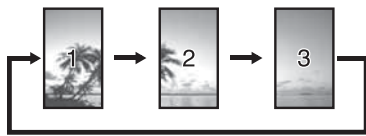

When Portrait Setup is “Off”:

Represent an area of the selected Location at a normal brightness and darken the rest of it.



Viewing Area and Location

The mode of image division and the Location by setting of Viewing Area is as follows.

Viewing Area : 16:9

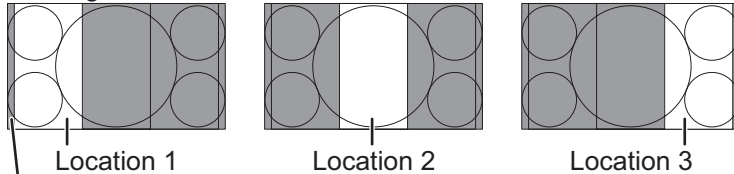

Undisplayed area (48 dots)

Viewing Area : 4:3

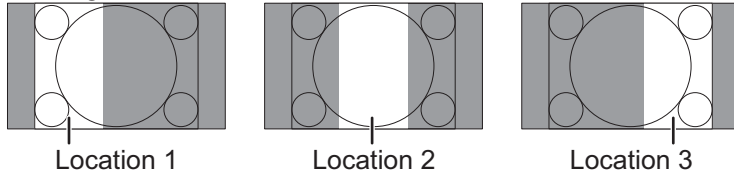

Suitable to display 16:9 images. 4:3 images extend transversely. Both right and left sides of the image are cut by 48 dots.

4:3 images are displayed without changing aspect ratio. Although the images of each Location overlap, you can adjust Pos./Size to display the image normally. (see page 23)

5 Video Wall Uniformity

Reduces the peak of brightness for each display to enable as uniform display as possible.

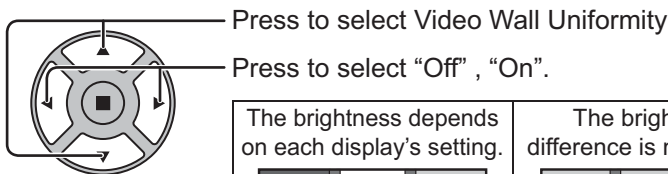

The brightness depends on each display's setting.	The brightness difference is minimized.
Off	On

Portrait Setup	
Portrait Setup	Off
Seam hides video	Off
Viewing Area	16 : 9
Location	1
Video Wall Uniformity	Off

Note:

If you set Video Wall Uniformity to On, the following menu will be unavailable and these settings will be fixed to the initial values.

Picture menu: Colour, Hue, Input level (Advanced settings)

Setup for Input Signals

Component / RGB-in select

Component \longleftrightarrow RGB

Select to match the signals from the source connected to the Component / RGB or PC input terminals.

Y, P_B, P_R signals \Leftrightarrow "Component"

RGB signals \Leftrightarrow "RGB"

Note:

Make setting of the selected input terminal (COMPONENT/RGB IN or PC IN).

YUV / RGB-in select

YUV \longleftrightarrow RGB

Select to match the signals from the source connected to the DVI input terminals.

YUV signals \Leftrightarrow "YUV"

RGB signals \Leftrightarrow "RGB"

Notes:

- Selection may not be possible, depending on which optional board is installed.
- Make setting of the selected input terminal (SLOT or DVI-D IN).

Signal menu

Notes:

- “Signal” setup menu displays a different setting condition for each input signal.
- Depending on the input signal type, an optional Terminal Board may be required.

Select “Signal” in “Setup” menu and press  button.



For Video (S VIDEO)

Signal [AV]	
FRAME CREATION	Mid
Colour system	Auto
Cinema reality	Off
Noise reduction	Off

For RGB

Signal [RGB]	
FRAME CREATION	Mid
Sync	Auto
Cinema reality	Off
XGA Mode	Auto
Noise reduction	Off
H-Freq.	63.98 kHz
V-Freq.	60.02 Hz
Signal Format	1280×1024/60i

For Component

Signal [Component]	
FRAME CREATION	Mid
Sync	Auto
Cinema reality	Off
XGA Mode	Auto
Noise reduction	Off
H-Freq.	63.98 kHz
V-Freq.	60.02 Hz
Signal Format	1280×1024/60i

For Digital

Signal [Digital]	
FRAME CREATION	Mid
Cinema reality	Off
HDMI Range	Auto
Noise reduction	Off
H-Freq.	63.98 kHz
V-Freq.	60.02 Hz
Signal Format	1280×1024/60i

• 3D Y/C Filter (NTSC)

This menu is displayed when BNC Dual Video Terminal Board (TY-FB9BD) is installed to the unit.

Set this menu when the moving image looks unnatural during Video (S Video) input signal.

On \longleftrightarrow Off

Note:

When On, this setting only affects NTSC input signals.

• Colour system

\rightarrow Auto \longleftrightarrow PAL \longleftrightarrow SECAM \longleftrightarrow M.NTSC \longleftrightarrow NTSC \leftarrow

Set the colour system to match the input signal. When “Auto” is set, Colour system will be automatically selected from NTSC/PAL/SECAM/M.NTSC.

To display PAL60 signal, select “Auto” or “PAL”.

If the picture image becomes unstable:

With the system set on Auto, under conditions of low level or noisy input signals the image may in rare cases become unstable. Should this occur, set the system to match the format of the input signal.

• Cinema reality

When “On”, the display attempts to reproduce a more natural interpretation of sources such as movie pictures, which are recorded at 24 frames per second.

If the picture is not stable, turn the setting to “Off”.

On \longleftrightarrow Off

Note:

When On, this setting only affects the following signal input:

- NTSC / PAL signal input during Video (S Video) input signal.
- 525i(480i), 625i(575i), 1125(1080)/60i signal input during “Component” input signal.

• XGA Mode

This menu is displayed when the input signal is analog (Component/PC). This unit supports three types of XGA signals with 60Hz vertical frequency having different aspect ratios and sampling rates (1,024 × 768 @ 60Hz, 1,280 × 768 @ 60Hz and 1,366 × 768 @ 60Hz).

Auto \longleftrightarrow 1024×768 \longleftrightarrow 1280×768 \longleftrightarrow 1366×768

Auto: Automatically selected from 1024×768/1280×768/1366×768.

Switch the setting to suit the input signal for better display depends on the angle of view or display resolution condition.

Note:

After making this setting, be sure to make each adjustment (such as “Auto Setup”) on the “Pos./Size” menu as necessary. (see page 23)

Setup for Input Signals

- **Sync**

This function operates only during input from PC IN terminal.

- **Setting RGB sync signal**

Confirm that the input is set to RGB input (this setting is valid only for RGB input signal).

Auto: The H and V sync or synchronized signal is automatically selected. If both input, it is selected the H and V sync.



on G: Uses a synchronized signal on the Video G signal, which is input from the G connector.

- **Setting Component sync signal**

Confirm that the input is set to Component input (this setting is valid only for Component input signal).

Auto: The H and V sync or synchronized signal is automatically selected. If both input, it is selected the H and V sync.



on Y: Uses a synchronized signal on the Video Y signal, which is input from the Y connector.

- **Note:**

Signals input to COMPONENT/RGB IN terminals correspond to Sync on G or Sync on Y.

- **SDI Through**

Set the active through function of the Dual Link HD-SDI Terminal Board (TY-FB11DHD).

On ↔ **Off**

On: Enables active through.

Off: Disables active through.

- **Note:**

Settings can only be performed for this menu when a slot mounted with a Dual Link HD-SDI Terminal Board (TY-FB11DHD) is selected.

- **FRAME CREATION**

Automatically compensates the picture frame rate and removes juddering movements to make the images smooth.

Off ↔ **Mid** ↔ **Max**

- **Note:**

Depending on the contents, images may be noisy. To prevent the noise, change the setting.

- **HDMI Range**

Switches the dynamic range according to the input signal from HDMI terminal.

Video(16-235) ↔ **Full(0-255)** ↔ **Auto**

Video(16-235): If the input signal is the video range, Example: HDMI terminal output for DVD player

Full(0-255): If the input signal is full range, Example: HDMI terminal output for personal computer

Auto: Switches the dynamic range automatically between "Video(16-235)" and "Full(0-255)" according to the input signal.

- **Note:**

This function can be set only for HDMI signal input.

• Noise reduction

Sets the following three NR (Noise Reduction) functions together.
P-NR, Mosquito NR, Block NR

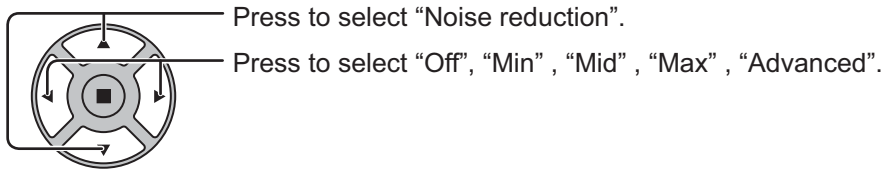

Advanced NR

Sets the three NR functions separately.

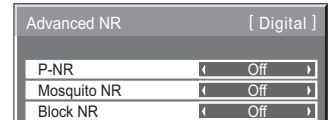
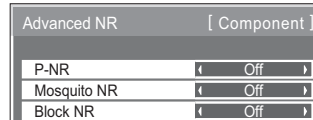
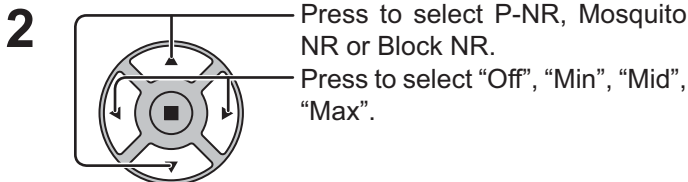
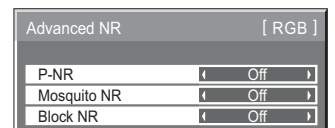
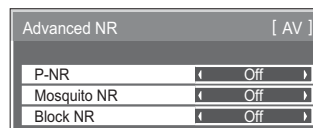
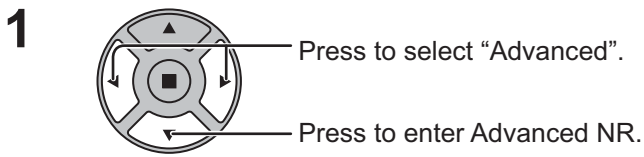

P-NR: Automatically reduces unwanted picture noise.

Mosquito NR: Reduces mosquito noise around subtitles on MPEG videos.

Block NR: Reduces block noise when playing MPEG videos.

Note:

Noise reduction cannot be adjusted while a PC signal is being applied.

• Input signal display

Displays the frequency and the type of the current input signal.

This display is valid only for Component / RGB / PC and Digital input signal.

Display range:

Horizontal 15 - 110 kHz
Vertical 48 - 120 Hz

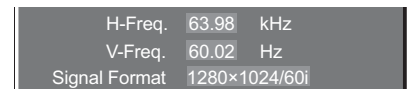



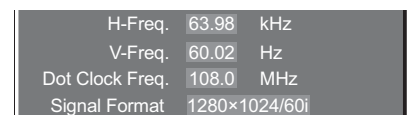

The dot clock frequency is displayed during DVI signal input.



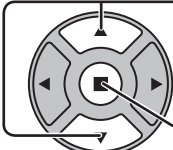

Options Adjustments

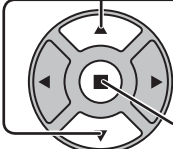
1  Press to display the Setup menu.

2  Press to select "OSD Language".
 Press for more than 3 seconds.



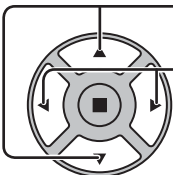

3  Press to select "Options".
 Press to display the Options menu.



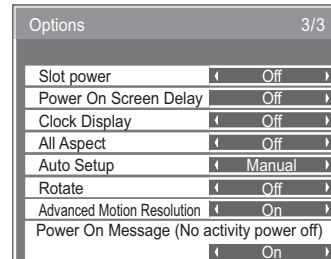
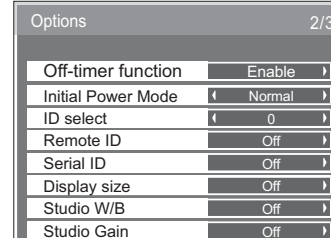
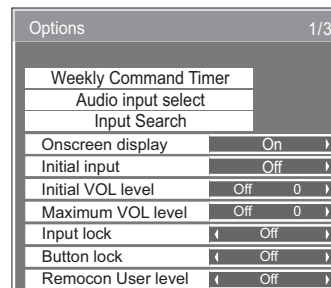

4  Press to select your preferred menu.
 Press to adjust the menu.







5  Press to exit from Options menu.



Item	Adjustments
Weekly Command Timer	Sets Weekly Command Timer. (see page 55)
Audio input select	Set up the sound when an image input is selected. (see page 57)
Input Search	Set auto input switching for when there is no signal. (see page 58)
Onscreen display	<p>On: Displays all the following on screen.</p> <ul style="list-style-type: none"> • Power on display • Input signal switch display • No signal display • Mute and the remaining time of off-timer after  was pressed. <p>Off: Hides all the items above from view.</p>
Initial input	<p>Adjusts the input signal when the unit is turned on.</p> <p>Off ↔ SLOT INPUT*1 ↔ VIDEO ↔ COMPONENT*2 ↔ HDMI ↔ DVI ↔ PC ↔ NETWORK</p> <p>*1 "SLOT INPUT" is displayed when an optional Terminal Board is installed.</p> <p>When a Terminal Board with dual input terminals is installed, "SLOT INPUT A" and "SLOT INPUT B" are displayed.</p> <p>*2 "COMPONENT" may be displayed as "RGB" depending on the setting of "Component/RGB-in select". (see page 48)</p> <p>Notes:</p> <ul style="list-style-type: none"> • Only the adjusted signal is displayed. (see page 17) • This menu is available only when "Input lock" is "Off".
Initial VOL level	<p>Press   button to adjust the volume when the unit is turned on.</p> <p>Off ↔ On</p> <p>Off: Sets normal volume.</p> <p>On: Sets your preferred volume.</p> <p>Notes:</p> <ul style="list-style-type: none"> • When "Maximum VOL level" is "On", the volume can only be adjusted between 0 and your maximum range. • You can hear the changed volume regardless of your volume setting before opening the options menu if you adjust the volume when "Initial VOL level" is "On" and cursor is on the menu.
Maximum VOL level	<p>Press   button to adjust the maximum volume.</p> <p>Off ↔ On</p> <p>Off: Sets auto maximum volume.</p> <p>On: Sets your preferred maximum volume.</p> <p>Notes:</p> <ul style="list-style-type: none"> • If the "Maximum VOL level" is set lower than the "Initial VOL level", the "Initial VOL level" automatically becomes the same as the "Maximum VOL level". • The volume display can go up to 63 regardless of the settings. • You can hear the changed volume regardless of your volume setting before opening the options menu if you adjust the volume when "Maximum VOL level" is "On" and cursor is on the menu.

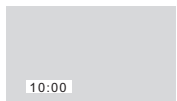

Item	Adjustments
Input lock	<p>Locks the input switch operation. Off ↔ SLOT INPUT*1 ↔ VIDEO ↔ COMPONENT*2 ↔ HDMI ↔ DVI ↔ PC ↔ NETWORK *1 "SLOT INPUT" is displayed when an optional Terminal Board is installed. When a Terminal Board with dual input terminals is installed, "SLOT INPUT A" and "SLOT INPUT B" are displayed. *2 "COMPONENT" may be displayed as "RGB" depending on the setting of "Component/RGB-in select". (see page 48) Notes: • Only the adjusted signal is displayed (see page 17). • Input switch can be used when this is set to "Off".</p>
Button lock	<p>Off ↔ MENU&ENTER ↔ On Off: All the buttons on main unit can be used. MENU&ENTER: Locks <input type="checkbox"/> MENU and <input type="checkbox"/> ENTER/■ buttons on main unit. On: Locks all the button on main unit. Sets Button lock with the unit buttons in the following procedure. Off: Press <input type="checkbox"/> +/▲ four times → Press <input type="checkbox"/> INPUT four times → Press <input type="checkbox"/> -/▼ four times → Press <input type="checkbox"/> ENTER/■ MENU&ENTER: Press <input type="checkbox"/> ENTER/■ four times → Press <input type="checkbox"/> +/▲ four times → Press <input type="checkbox"/> INPUT four times → Press <input type="checkbox"/> ENTER/■ On: Press <input type="checkbox"/> -/▼ four times → Press <input type="checkbox"/> ENTER/■ four times → Press <input type="checkbox"/> +/▲ four times → Press <input type="checkbox"/> ENTER/■</p>
Remocon User level	<p>Off ↔ User1 ↔ User2 ↔ User3 Off: You can use all of the buttons on the remote control. User1: You can only use <input type="radio"/> INPUT, <input type="radio"/> RESOL, <input type="radio"/> MUTE, <input type="radio"/> CH, <input type="radio"/> + buttons on the remote control. User2: You can only use <input type="radio"/> INPUT button on the remote control. User3: Locks all the buttons on remote control.</p>
Off-timer function	<p>Enable: Enables the "Off-timer function". Disable: Disables the "Off-timer function". Note: When "Disable" is set, the Off-timer is cancelled.</p>
Initial Power Mode	<p>Normal ↔ Standby ↔ On Sets the power mode of the unit for when the power recovers from failure or after plugging off and in again. Normal: Power returns in as the same state as before the power interruption. Standby: Power returns in standby mode. (Power Indicator : red/orange) On: Power returns in power On. (Power Indicator : green) Note: When using multiple displays, "Standby" is preferred to be set in order to reduce a power load.</p>
ID select	<p>Sets panel ID number when panel is used in "Remote ID" or "Serial ID". Set value range: 0 - 100 (Standard value: 0)</p>
Remote ID	<p>The setting of this menu is valid only when using ID remote control. Off: Disables ID remote control functions. You can use normal remote control operations. On: Enable ID remote control functions. Note: To use the ID remote control function, it is necessary to set each ID number of remote control and display unit. About the setting method, please refer to "ID Remote Control Function" (see page 45) and "ID select" (above-mentioned).</p>
Serial ID	<p>Sets the panel ID Control. Off: Disables external control by the ID. On: Enables the external control by the ID.</p>
Display size	<p>Adjusts the image display size on screen. Off: Sets the normal image display size on screen. On: Sets the image display size approximately 95 % of the normal image display.</p> <div style="display: flex; justify-content: space-around; align-items: center;"> <div style="text-align: center;"> <p>Off</p>  </div> <div style="text-align: center;"> <p>On</p>  </div> </div> <p>Notes:</p> <ul style="list-style-type: none"> • This setting is valid only when the input signals are as follows; NTSC, PAL, SECAM, M.NTSC, PAL60, PAL-M, PAL-N (Video) 525i, 525p, 625i, 625p, 750/60p, 750/50p, 1125/60i, 1125/50i, 1125/24sF, 1125/25p, 1125/24p, 1125/30p, 1125/60p, 1125/50p, 1250/50i (Component Video, RGB, DVI, SDI, HDMI) • This setting is invalid when digital zoom, Multi display or Portrait display is selected. • When "Display size" is set to "On", "H-Pos" and "V-Pos" in "Pos./Size" can be adjusted. • Refer to each board's operating instruction for DVI, SDI, HDMI's corresponding signals.

Options Adjustments

Item	Adjustments
Studio W/B	Off: Nullify all the settings adjusted. On: Sets the colour temperature for TV studio. Note: Valid only when the "Warm" is set as "White balance" in Picture menu.
Studio Gain	Sharpens the contrast for a better view when a part of the image is too light to see. Off: Disables "Studio Gain". On: Enables "Studio Gain". Note: This setting is valid only when the input signals are as follows: Component Video, RGB (analog), SDI, HDMI
Slot power	Off ↔ Auto ↔ On Off: Power is not transmitted to the slot power. Auto: Power is transmitted to the slot power only when main power is on. On: Power is transmitted to the slot power when main power is on or in the standby state. Note: In some cases, power is transmitted to the slot power when main power is on or in the standby state regardless of the slot power setting.
Power On Screen Delay	Off ↔ 1 ↔ 2 ↔ 3... ↔ 30 You can set the power-on delay time of the displays to reduce the power load, when you press  /I to turn on the multiple displays that are set together, for example, on MULTI DISPLAY system. Set each display's setting individually. Off: The display will be turned on at the same time as  /I is pressed. 1 to 30 (sec.): Set the power-on delay time (second). After pressing  , the display will be powered on with time delay depending on this setting. Notes: <ul style="list-style-type: none"> • During this function is working, the power indicator is blinking green. • This function also works when the power recovers from failure or after plugging off and in again the power cord. After you unplug and plug the power cord in while the unit is in standby mode and also the power is being supplied to a terminal board, the unit will start supplying the power to the board with time delay according to the setting. The power indicator lights up red first and it turns orange when the power starts being supplied to the board.
Clock Display	Off: Not display the clock. On: Display the clock. The clock is displayed at the lower left of the screen when  button is pressed.  Note: When "Day/Time Setup" is not set, the clock is not displayed even if "Clock Display" is "On". (see page 33)
All Aspect	Sets All Aspect mode (advanced aspect setting) or default aspect mode. With each press of  button, the aspect changes in the selected mode. Off: Default aspect mode On: All Aspect mode Aspect mode of each setting is as follows: (Example: HD signal) Off 4:3→4:3 Full→Zoom1→Zoom2→Zoom3→16:9→14:9→Just On 4:3 (1)→4:3 (2)→4:3 Full→Zoom1→Zoom2→Zoom3→16:9→14:9→Just1→Just2
Auto Setup	Sets the operational mode of the automatic position adjustment in the Pos./Size menu. Manual: Automatic position adjustment starts when  is pressed on the remote control or automatic position adjustment is executed from the Pos./Size menu. Auto: Other than remote control or menu operation, automatic position adjustment starts: When the display power is turned ON. When the input signal is switched.
Rotate	Off: Does not rotate the image. On: Rotates the image 180 degrees.
Advanced Motion Resolution	Displays motion picture images at higher resolution. On ↔ Off Note: Please set to "Off" if images look unnatural.
Power On Message (No activity power off)	Whether to show/hide No activity power off Precautions at the time of power ON is set. On: The warning precautions are shown at the time of power ON. Off: The warning precautions are not shown at the time of power ON. Note: This setting is enabled only if "No activity power off" is "Enable" (see page 43).

Normalisation

When both main unit buttons and remote control are disabled due to the “Button lock”, “Remocon User level” or “Remote ID” adjustments, set all the values “Off” so that all the buttons are enabled again.

Press the  button on main unit together with  button on the remote control and hold for more than 5 seconds. The “Shipping” menu is displayed and the lock is released when it disappears.

Weekly Command Timer

You can set 7-day timer programming by setting time and command.

Note:

Before setting Weekly Command Timer, set Day/Time Setup. (see page 33)

1

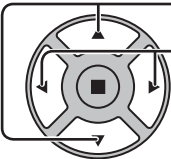

Press to select Function.
Press to select “On”.

Note:

- When Function is set to On, On/Off Timer Setup (see page 33) is unavailable and Interval / Time Designation in Mode of Screensaver (see page 35) cannot be selected.

2

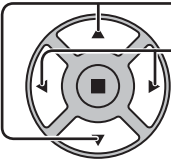

Press to select a day.
Press to select a program number.

Note:

- You can set the program from 1 to 7. --- indicates unset.

3

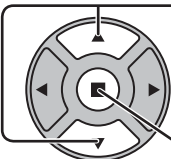

Press to select Program Edit.
Press to show the Program Edit screen.

4

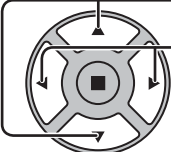

Press to select Program.
Press to change the program numbers (1-7).

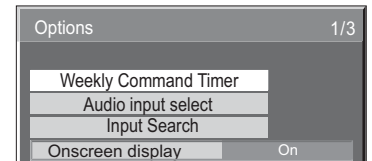

↓ Press ACTION (■) button

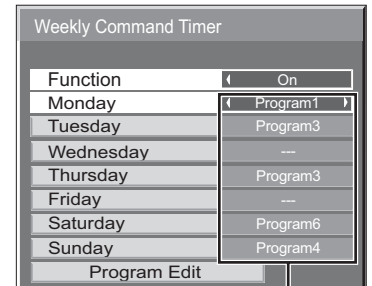

Program number

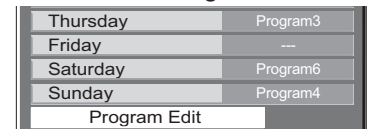

Program Edit screen

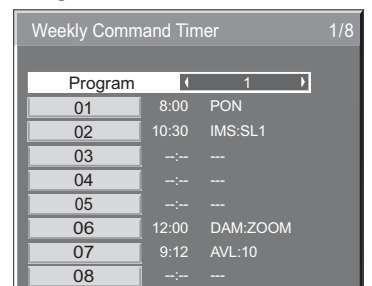

Options Adjustments

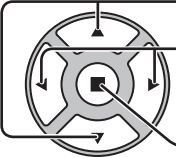
- 5**
- 
- Press to select a command number.
 - Press to show the previous / next command pages (1-8) of the selected program.
 - Press to show the command setting screen.

Weekly Command Timer			1/8
Program			1
01	8:00	PON	
02	10:30	IMS:SL1	
03	--:--	--	
04	--:--	--	
05	--:--	--	
06	12:00	DAM:ZOOM	
07	9:12	AVL:10	
08	--:--	--	

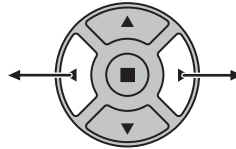

Weekly Command Timer			8/8
Program			1
57	20:00	AVL:00	
58	20:30	DAM:NORM	
59	22:00	POF	
60	--:--	--	
61	--:--	--	
62	--:--	--	
63	--:--	--	
64	--:--	--	

Command (--- indicates unset)
 Set time of timer(--:-- indicates unset)
 Command numbers

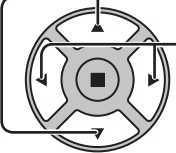
- 6**
- 
- Press to select Command No.
 - Press to select a command number.

Command setting screen

Weekly Command Timer	
Program	
Command No	02
Time	10:30
Command	IMS:SL1

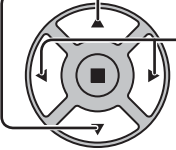
- 7**
- 
- Press to select Time / Command.
 - Press to set each item.
- Time: Set the time to execute a command program.
 Pressing “◀” or “▶” button once changes “Time” 1 minute.
 Pressing “◀◀” or “▶▶” button continuously changes “Time” by 15 minutes.

Weekly Command Timer	
Program	
Command No	02
Time	10:30
Command	IMS:SL1

Command: Select a command to execute at the set time. This unit has 64 commands to set. (see page 63)

Notes:

- Command is performed in order of execution time, regardless of the command number.
- If a command execution time overlaps with that of other commands, these commands are performed in number order.
- Pressing , Time becomes --:-- and Command becomes ---.

Note:
 Press  to return to the previous screen.

Audio input select

Set up the sound when an image input is selected.

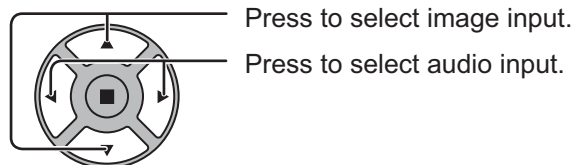

Press to select image input.

Press to select audio input.

Image input

[SLOT INPUT]*1

[VIDEO]

[COMPONENT]*2

[HDMI]

[DVI]

[PC]

[NETWORK]

Audio input

SLOT INPUT / VIDEO/COMPONENT / DVI/PC / NETWORK / NO AUDIO

SLOT INPUT / VIDEO/COMPONENT / DVI/PC / NETWORK / NO AUDIO

SLOT INPUT / VIDEO/COMPONENT / DVI/PC / NETWORK / NO AUDIO

SLOT INPUT / VIDEO/COMPONENT / HDMI / DVI/PC / NETWORK / NO AUDIO

SLOT INPUT / VIDEO/COMPONENT / DVI/PC / NETWORK / NO AUDIO

SLOT INPUT / VIDEO/COMPONENT / DVI/PC / NETWORK / NO AUDIO

SLOT INPUT / VIDEO/COMPONENT / DVI/PC / NETWORK / NO AUDIO

VIDEO/COMPONENT: Sound input for both VIDEO and COMPONENT.

DVI/PC: Sound input for both DVI and PC.

NO AUDIO: No audio input (Mute)

*1 "SLOT INPUT" is displayed when a Terminal Board is installed.

*2 "COMPONENT" may be displayed as "RGB" depending on the setting of "Component/RGB-in select".
(see page 48)

When a Terminal Board with dual input terminals is installed

"SLOT INPUT" is displayed as "SLOT INPUT A" and "SLOT INPUT B" and independent settings are available.
To set other image inputs, you can select "SLOT INPUT A" and "SLOT INPUT B".

Image input

[SLOT INPUT A]

[SLOT INPUT B]

[VIDEO]

[COMPONENT]

[HDMI]

[DVI]

[PC]

[NETWORK]

Audio input

SLOT INPUT A / VIDEO/COMPONENT / DVI/PC / NETWORK / NO AUDIO

SLOT INPUT B / VIDEO/COMPONENT / DVI/PC / NETWORK / NO AUDIO

SLOT INPUT A / SLOT INPUT B / VIDEO/COMPONENT / DVI/PC / NETWORK / NO AUDIO

SLOT INPUT A / SLOT INPUT B / VIDEO/COMPONENT / DVI/PC / NETWORK / NO AUDIO

SLOT INPUT A / SLOT INPUT B / VIDEO/COMPONENT / HDMI / DVI/PC / NETWORK / NO AUDIO

SLOT INPUT A / SLOT INPUT B / VIDEO/COMPONENT / DVI/PC / NETWORK / NO AUDIO

SLOT INPUT A / SLOT INPUT B / VIDEO/COMPONENT / DVI/PC / NETWORK / NO AUDIO

SLOT INPUT A / SLOT INPUT B / VIDEO/COMPONENT / DVI/PC / NETWORK / NO AUDIO

When Image input and Audio input differ from each other, the Audio input is displayed as below.

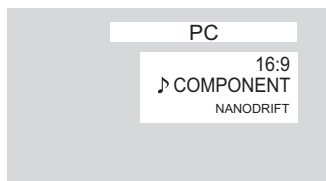

Notes:

- HDMI Audio is selectable only for HDMI Input.
- You cannot set audio of B for SLOT INPUT A, or audio of A for SLOT INPUT B.

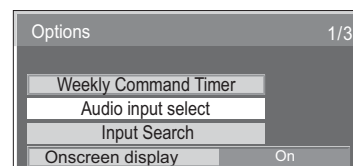

Press ACTION (■) button

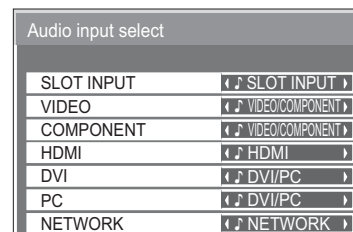

Input Search

When a signal is not detected, another input with a signal is automatically selected.

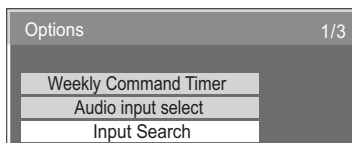

↓ Press ACTION (■) button

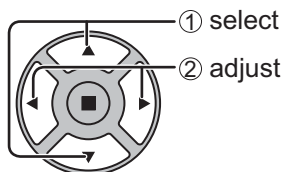
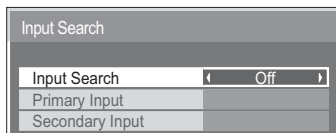

Input Search

Off: When there is no signal, the input is not switched automatically.

All Inputs: Searches all inputs and switches to an input with a signal.

Input search is executed in the following order.

(Example) When the current input is PC



Priority: Searches "Primary Input" and "Secondary Input" in order and switches to an input with a signal.

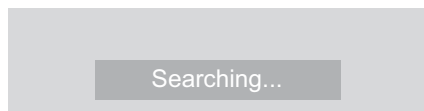

"Searching..." is displayed during the input search.

Primary Input, Secondary Input

Set the input to search when "Priority" is selected.

(NONE) <=> SLOT INPUT* <=> VIDEO <=> COMPONENT <=> HDMI <=> DVI <=> PC <=> NETWORK

* "SLOT INPUT" is displayed when an optional Terminal Board is installed.











When a Terminal Board with dual input terminals is installed, "SLOT INPUT A" and "SLOT INPUT B" are displayed.

Notes:

- This menu is available only when "Input lock" is "Off". (see page 53)
- If the input is changed by this function, the last input is selected when the power is turned on next time. If you wish to retain the original input when the power is turned on, set "Initial input" to the original input. (see page 52)

Troubleshooting

Before you call for service, determine the symptoms and make a few simple checks as shown below.

Symptoms		Checks
Picture	Sound	
 Interference	 Noisy Sound	Electrical Appliances Cars / Motorcycles Fluorescent light
 Normal Picture	 No Sound	Volume (Check whether the mute function has been activated on the remote control.) Check if speakers are connected properly.
 No Picture	 No Sound	Not plugged into AC outlet Not switched on Picture and Brightness/Volume setting (Check by pressing the power switch or stand-by button on the remote control.)
 No Picture	 Normal Sound	If a signal with a non-applicable colour system format, or frequency is input, only the input terminal indication is displayed.
 No Colour	 Normal Sound	Colour controls set at minimum level (see page 26, 27) Colour system (see page 49)
No remote control operations can be performed.		Check whether the batteries have discharged completely and, if they have not, whether they were inserted properly. Check whether the remote control sensor is exposed to an outdoor light or a strong fluorescent light. Check whether the remote control designed specifically for use with the unit is being used. (The unit cannot be operated by any other remote control.)
A cracking sound is sometimes heard from the unit.		If there is nothing wrong with the picture or sound, this is the sound of the cabinet undergoing very slight contractions in response to changes in the room temperature. There are no adverse effects on the performance or other aspects.
The top or bottom of the picture on the screen is cut off when I use the zoom function.		Adjust the position of the picture on the screen.
Areas at the top and bottom of the screen where the image is missing appear when I use the zoom function.		When using a video software program (such as a cinema size program) with a screen wider than one in the 16:9 mode, blank areas separate from the images are formed at the top and bottom of the screen.
I can hear sounds coming from inside the unit.		When the power is turned on, a sound of the display panel being driven may be heard: This is normal and not indicative of malfunctioning.
Parts of the unit become hot.		Even when the temperature of parts of the front, top and rear panels has risen, these temperature rises will not pose any problems in terms of performance or quality.
Power automatically turns off unexpectedly.		Check the settings of "PC Power management", "DVI-D Power management", "No signal power off" and "No activity power off" in the Setup menu. Any of them may be set to "On (Enable)". (see page 40, 43)
Power indicator is blinking in red.		There is possibility of malfunction. Please contact an Authorized Service Center.
This Plasma Display uses special image processing. Hence a slight time lag may occur between image and audio, depending on the type of input signal. However, this is not a malfunction.		

Plasma Display panel

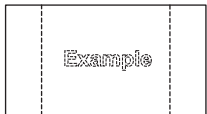
Symptoms	Check
The screen darkens slightly when bright pictures with minimal movements are shown.	The screen will darken slightly when photos, still images of a computer or other pictures with minimal movements are shown for an extended period. This is done to reduce image retention on the screen and the shortening of the screen's service life: It is normal and not indicative of malfunctioning.
It takes a while for the picture to appear.	The unit digitally processes the various signals in order to reproduce esthetically pleasing images. As such, it sometimes takes a few moments for the picture to appear when the power has been turned on, when the input has been switched.
The edges of the images flicker.	Due to the characteristics of the system used to drive the panel, the edges may appear to flicker in the fast-moving parts of the images: This is normal and not indicative of malfunctioning.
The brightness on both sides of images in the 4:3 mode changes.	When viewing the side panels at the "High" or "Mid" setting, the brightness on both sides may change depending on the kind of program shown: This is normal and not indicative of malfunctioning.
Some parts of the screen do not light up.	The plasma display panel is manufactured using an extremely high level of precision technology, however, sometimes some parts of the screen may be missing picture elements or have luminous spots. This is not a malfunction.
 Image retention appears	Do not allow a still picture to be displayed for an extended period, as this can cause a permanent image retention to remain on the Plasma Display. Examples of still pictures include logos, video games, computer images, teletext and images displayed in 4:3 mode. Note: The permanent image retention on the Plasma Display resulting from fixed image use is not an operating defect and as such is not covered by the Warranty. This product is not designed to display fixed images for extended periods of time.
Whirring sounds can be heard from the display unit.	The display unit is fitted with a cooling fan to dissipate heat generated during normal use. The whirring sound is caused by rotation of the fan and is not a malfunction.

List of Aspect Modes

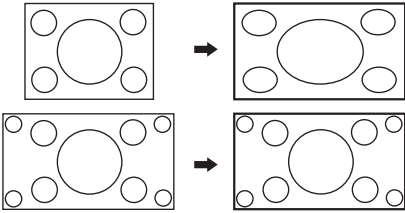
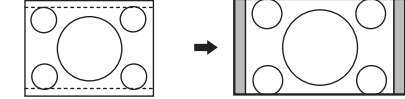
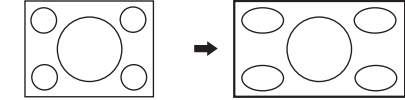
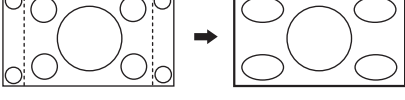
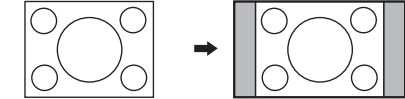
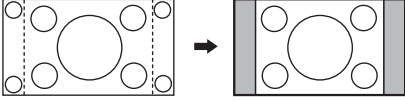
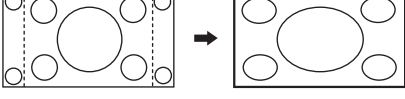
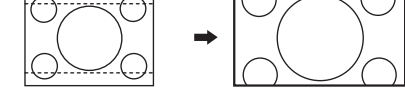
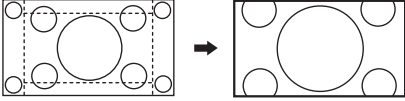
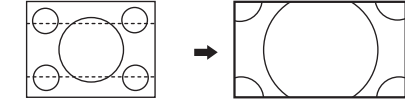
Aspect mode		Picture → Enlarged screen	Description
All Aspect: On	Factory setting All Aspect: Off		
16:9	16:9		The display of the pictures fills the screen. In the case of SD signals, pictures with a 4:3 aspect ratio are enlarged horizontally, and displayed. This mode is suited to displaying anamorphic pictures with a 16:9 aspect ratio.
14:9	14:9		Letterbox pictures with a 14:9 aspect ratio are enlarged vertically and horizontally so that their display fills the screen vertically and is slightly smaller than the screen horizontally. The top and bottom edges of the pictures are cut off. Side panels are displayed at the left and right edges of the screen.
Just ----- Just1	Just		Pictures with a 4:3 aspect ratio are enlarged horizontally so that the picture distortion is minimized. The display of the areas around the left and right edges of the screen is slightly elongated.
Just2	–		The pictures with a 4:3 aspect ratio among the 16:9 aspect ratio signals are enlarged horizontally so that the picture distortion is minimized. The left and right edges of the pictures are cut off. The display of the areas around the left and right edges of the screen is slightly elongated.
4:3 ----- 4:3 (1)	4:3		Pictures with a 4:3 aspect ratio are displayed with their original aspect ratio. Side panels are displayed at the left and right edges of the screen.
4:3 (2)	–		The pictures with a 4:3 aspect ratio among the 16:9 aspect ratio signals are displayed with their original aspect ratio. The left and right edges of the pictures are masked with side panels.
4:3 Full	4:3 Full		The pictures with a 4:3 aspect ratio among the 16:9 aspect ratio signals are enlarged horizontally so that their display fills the screen. The left and right edges of the pictures are cut off.
Zoom ----- Zoom1	Zoom1		Letterbox pictures with a 16:9 aspect ratio are enlarged vertically and horizontally so that their display fills the screen. The top and bottom edges of the pictures are cut off.
Zoom2	Zoom2		The letterbox pictures with a 2.35:1 aspect ratio among the 16:9 aspect ratio signals are enlarged vertically and horizontally so that their display fills the screen. The top and bottom edges as well as the left and right edges of the pictures are cut off.
Zoom3	Zoom3		Letterbox pictures with a 2.35:1 aspect ratio are enlarged vertically and horizontally so that their display fills the screen vertically and is slightly larger than the screen horizontally. The top and bottom edges as well as the left and right edges of the pictures are cut off.

Applicable Input Signals

*Mark: Applicable input signal

	Signal name	Horizontal frequency (kHz)	Vertical frequency (Hz)	COMPONENT / RGB IN / PC IN (Dot clock (MHz))	DVI-D IN (Dot clock (MHz))	HDMI
1	525 (480) / 60i	15.73	59.94	* (13.5)	* (27.0)	*
2	525 (480) / 60p	31.47	59.94	* (27.0) *5	* (27.0)	*
3	625 (575) / 50i	15.63	50.00	* (13.5)		
4	625 (576) / 50i	15.63	50.00		* (27.0)	*
5	625 (575) / 50p	31.25	50.00	* (27.0)		
6	625 (576) / 50p	31.25	50.00		* (27.0)	*
7	750 (720) / 60p	45.00	60.00	* (74.25)	* (74.25)	*
8	750 (720) / 50p	37.50	50.00	* (74.25)	* (74.25)	*
9	1,125 (1,080) / 60p	67.50	60.00	* (148.5) *1	* (148.5)	*
10	1,125 (1,080) / 60i	33.75	60.00	* (74.25) *1	* (74.25)	*
11	1,125 (1,080) / 50p	56.26	50.00	* (148.5) *1	* (148.5)	*
12	1,125 (1,080) / 50i	28.13	50.00	* (74.25) *1	* (74.25)	*
13	1,125 (1,080) / 24sF	27.00	48.00	* (74.25) *2		
14	1,125 (1,080) / 30p	33.75	30.00	* (74.25) *1	* (74.25)	
15	1,125 (1,080) / 25p	28.13	25.00	* (74.25) *1	* (74.25)	
16	1,125 (1,080) / 24p	27.00	24.00	* (74.25) *1	* (74.25)	*
17	1,250 (1,080) / 50i	31.25	50.00	* (74.25) *3		
18	2,048 × 1,080 / 24sF *7	27.00	48.00			
19	2,048 × 1,080 / 24p *7	27.00	24.00			
20	640 × 400 @70 Hz	31.46	70.07	* (25.17)		
21	640 × 480 @60 Hz	31.47	59.94	* (25.18) *6	* (25.18)	*
22	640 × 480 @72 Hz	37.86	72.81	* (31.5)		
23	640 × 480 @75 Hz	37.50	75.00	* (31.5)		
24	640 × 480 @85 Hz	43.27	85.01	* (36.0)		
25	800 × 600 @56 Hz	35.16	56.25	* (36.0)		
26	800 × 600 @60 Hz	37.88	60.32	* (40.0)	* (40.0)	*
27	800 × 600 @72 Hz	48.08	72.19	* (50.0)		
28	800 × 600 @75 Hz	46.88	75.00	* (49.5)		
29	800 × 600 @85 Hz	53.67	85.06	* (56.25)		
30	852 × 480 @60 Hz	31.47	59.94	* (33.54) *6	* (34.24)	*
31	1,024 × 768 @50 Hz	39.55	50.00		* (51.89)	*
32	1,024 × 768 @60 Hz	48.36	60.00	* (65.0)	* (65.0)	*
33	1,024 × 768 @70 Hz	56.48	70.07	* (75.0)		
34	1,024 × 768 @75 Hz	60.02	75.03	* (78.75)		
35	1,024 × 768 @85 Hz	68.68	85.00	* (94.5)		
36	1,066 × 600 @60 Hz	37.64	59.94	* (53.0)	* (53.0)	*
37	1,152 × 864 @60 Hz	53.70	60.00		* (81.62)	*
38	1,152 × 864 @75 Hz	67.50	75.00	* (108.0)		
39	1,280 × 768 @60 Hz	47.70	60.00	* (80.14)		
40	1,280 × 800 @60 Hz (1)	49.31	59.91	* (71.0)	* (71.0)	*
41	1,280 × 800 @60 Hz (2)	49.70	59.81	* (83.5)	* (83.5)	*
42	1,280 × 960 @60 Hz	60.00	60.00	* (108.0)		
43	1,280 × 960 @85 Hz	85.94	85.00	* (148.5)		
44	1,280 × 1,024 @60 Hz	63.98	60.02	* (108.0)	* (108.0)	*
45	1,280 × 1,024 @75 Hz	79.98	75.03	* (135.0)		
46	1,280 × 1,024 @85 Hz	91.15	85.02	* (157.5)		
47	1,366 × 768 @50 Hz	39.55	50.00		* (69.92)	*
48	1,366 × 768 @60 Hz	48.36	60.00	* (86.71)	* (87.44)	*
49	1,400 × 1,050 @60 Hz	65.22	60.00		* (122.61)	*
50	1,440 × 900 @60 Hz (1)	55.47	59.90	* (88.75)	* (88.75)	*
51	1,440 × 900 @60 Hz (2)	55.93	59.89	* (106.5)	* (106.5)	*
52	1,600 × 1,200 @60 Hz	75.00	60.00	* (162.0)	* (162.0)	*
53	1,600 × 1,200 @65 Hz	81.25	65.00	* (175.5)		
54	1,920 × 1,080 @60 Hz	67.50	60.00	* (148.5) *4	* (148.5)	*
55	1,920 × 1,200 @60 Hz	74.04	59.95		* (154.0)	*
56	Macintosh13" (640 × 480)	35.00	66.67	* (30.24)		
57	Macintosh16" (832 × 624)	49.72	74.54	* (57.28)		
58	Macintosh21" (1,152 × 870)	68.68	75.06	* (100.0)		

*1: Based on SMPTE 274M standard.

*2: Based on SMPTE RP211 standard.

*3: Based on SMPTE 295M standard.

*4: The input signal is recognized as 1,125 (1,080) / 60p.

*5: When selected the RGB format and 525p signal input to the PC IN terminal, it is recognized as VGA 60Hz signal.

*6: When inputted VGA 60Hz format signal from the other than PC IN terminal, it is recognized as 525p signal.

*7: Based on SMPTE 292M and 372M standards. These signals can be received when the Dual Link HD-SDI Terminal Board (TY-FB11DHD) is installed.

Note: Signals without above specification may not be displayed properly.



Applicable Input Signals

Video input (VIDEO)

	Signal name	Horizontal frequency(kHz)	Vertical frequency(Hz)
1	NTSC	15.73	59.94
2	PAL	15.63	50.00
3	PAL60	15.73	59.94
4	SECAM	15.63	50.00
5	Modified NTSC	15.73	59.94

Shipping condition

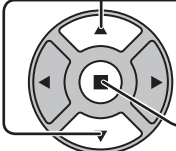
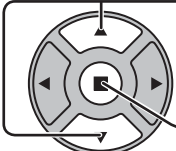
This function allows you to reset the unit to the factory setting.

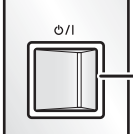
- 1  Press to display the Setup menu.
- 2  Press to select "OSD Language".
Press for more than 3 seconds.
- 3  Press to select "Shipping".
Press to display the Shipping menu.
- 4  Press to select "YES".
Press to confirm.
- 5 Wait for 10 seconds.
- 6  Press the power switch (⏻/⏻) on main unit to turn the power off.

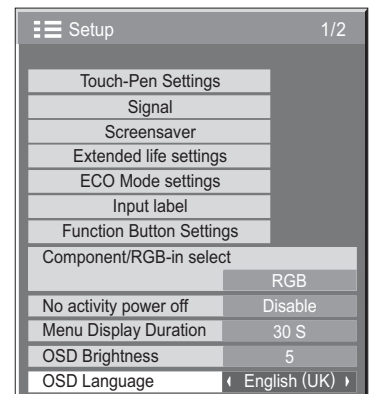

[from the unit]

- 1 Press the MENU button till the Setup menu is displayed.
- 2 Press the Volume Up "+" or Down "-" button to select "OSD Language".
- 3 Press and hold the ENTER button till the Shipping menu is displayed.
- 4 Press the Volume Up "+" or Down "-" button to select "YES".
- 5 Press the ENTER button and wait for 10 sec.
- 6 Press the power switch (⏻/⏻) on main unit to turn the power off.

Command list of Weekly Command Timer

No.	Command	Control details
1	AAC:MENCLR	Audio Menu (Clear)
2	AAC:MENDYN	Audio Menu (Dynamic)
3	AAC:MENSTD	Audio Menu (Standard)
4	AAC:SURMON	Surround (ON)
5	AAC:SUROFF	Surround (OFF)
6	AMT:0	Audio Mute (OFF)
7	AMT:1	Audio Mute (ON)
8	-	-
9	-	-
10	AVL:00	Audio Volume (00)
11	AVL:10	Audio Volume (10)
12	AVL:20	Audio Volume (20)
13	AVL:30	Audio Volume (30)
14	AVL:40	Audio Volume (40)
15	AVL:50	Audio Volume (50)
16	AVL:60	Audio Volume (60)
17	DAM:FULL	Aspect (16:9)
18	DAM:JUST	Aspect (Just)
19	DAM:NORM	Aspect (4:3)
20	-	-
21	DAM:ZOOM	Aspect (Zoom)
22	-	-
23	-	-
24	-	-
25	-	-
26	-	-
27	-	-
28	-	-
29	-	-
30	-	-
31	-	-
32	-	-
33	-	-
34	-	-
35	-	-
36	-	-
37	-	-
38	-	-
39	IMS:SL1	Input select (SLOT INPUT)
40	IMS:S1A	Input select (SLOT INPUT A)
41	IMS:S1B	Input select (SLOT INPUT B)
42	IMS:VD1	Input select (VIDEO)
43	IMS:YP1	Input select (COMPONENT)
44	IMS:HM1	Input select (HDMI)
45	IMS:DV1	Input select (DVI)
46	IMS:PC1	Input select (PC)
47	IMS:NW1	Input select (NETWORK)
48	-	-
49	-	-
50	-	-
51	-	-
52	-	-
53	-	-
54	-	-
55	OSP:SCR0	Screen Saver Scrolling bar only (OFF)
56	OSP:SCR1	Screen Saver Scrolling bar only (ON)
57	POF	Power OFF
58	PON	Power ON
59	SSC:FNC0	Screen Saver function (Scrolling bar only)
60	SSC:FNC1	Screen Saver function (Negative image)
61	SSC:MOD0	Screen Saver (Mode (OFF))
62	SSC:MOD3	Screen Saver (Mode (ON))
63	VMT:0*	Picture Mute (OFF)
64	VMT:1*	Picture Mute (ON)

* Picture Mute cannot be unlocked by powering off/on with the remote control. Turn off and on again with the button on the unit or enter the command VMT:0 to unlock Picture Mute.

Specifications

		TH-85PB1E	TH-103PB1E
Power Source		220 - 240 V AC, 50/60 Hz	
Power Consumption			
	Power on	1,090 W	1,250 W
	Stand-by condition	0.5 W	0.5 W
	Power off condition	0.3 W	0.3 W
Plasma Display panel		Drive method : AC type 85-inch, 16:9 aspect ratio	Drive method : AC type 103-inch, 16:9 aspect ratio
Screen size		1,889 mm (W) × 1,062 mm (H) × 2,167 mm (diagonal)	2,269 mm (W) × 1,276 mm (H) × 2,603 mm (diagonal)
	(No. of pixels)	2,073,600 (1,920 (W) × 1,080 (H)) [5,760 × 1,080 dots]	
Operating condition			
	Temperature	0 °C - 40 °C	
	Humidity	20 % - 80 %	
Applicable signals			
	Colour System	NTSC, PAL, PAL60, SECAM, Modified NTSC	
	Scanning format	525 (480) / 60i · 60p, 625 (575) / 50i · 50p, 750 (720) / 60p · 50p, 1125 (1080) / 60i · 60p · 50i · 50p · 24p · 25p · 30p · 24sF, 1250 (1080) / 50i	
	PC signals	VGA, SVGA, XGA, SXGA UXGA (compressed) Horizontal scanning frequency 15 - 110 kHz Vertical scanning frequency 48 - 120 Hz	
Connection terminals			
AV IN	VIDEO	BNC	1.0 Vp-p (75 Ω)
	AUDIO L-R	RCA Pin jack × 2	0.5 Vrms, Shared with COMPONENT/RGB IN
	HDMI	TYPE A Connector	
COMPONENT/RGB IN			
	Y/G	BNC	with sync 1.0 Vp-p (75 Ω)
	PB/CB/B	BNC	0.7 Vp-p (75 Ω)
	PR/CR/R	BNC	0.7 Vp-p (75 Ω)
	AUDIO L-R	RCA Pin jack × 2	0.5 Vrms, Shared with VIDEO
DVI-D IN		DVI-D 24 Pin	Compliance with DVI Revision 1.0
	AUDIO	Content Protection Stereo mini jack (M3) × 1	Compatible with HDCP 1.1 0.5 Vrms, Shared with PC IN
PC IN		High-Density Mini D-sub 15 Pin	Y or G with sync 1.0 Vp-p (75 Ω) Y or G without sync 0.7 Vp-p (75 Ω) PB/CB/B: 0.7 Vp-p (75 Ω) PR/CR/R: 0.7 Vp-p (75 Ω) HD/VD: 1.0 - 5.0 Vp-p (high impedance)
	AUDIO	Stereo mini jack (M3) × 1	0.5 Vrms, Shared with DVI-D IN
SERIAL		External Control Terminal D-sub 9 Pin	RS-232C compatible
WIRELESS MODULE		for Wireless module (ET-WM200E)	
LAN		RJ45 10BASE-T/100BASE-TX, compatible with PLink™	
AUDIO OUT	L-R	RCA Pin jack × 2 (L / R) OUTPUT LEVEL : VARIABLE (-∞ ~ 0 dB)	[INPUT 1 kHz / 0 dB, 10 kΩ Load]
Sound			
	Speakers	160 mm × 40 mm × 2 pcs	
	Audio Output	20 W [10 W + 10 W] (10 % THD)	
Dimensions (W × H × D)		2,015 mm × 1,195 mm × 99 mm	2,412 mm × 1,419 mm × 134 mm
Mass (weight)		approx. 115 kg net	approx. 189 kg net

Notes:

- Design and specifications are subject to change without notice. Mass and dimensions shown are approximate.
- This equipment complies with the EMC standards listed below.
EN55022, EN55024, EN61000-3-2, EN61000-3-3.

This product incorporates the following software:

- (1) the software developed independently by or for Panasonic Corporation,
- (2) the software owned by third party and licensed to Panasonic Corporation,
- (3) the software licensed under the GNU General Public License, Version 2.0 (GPL-2.0),
- (4) the software licensed under the GNU LESSER General Public License, Version 2.1 (LGPL-2.1) and/or,
- (5) open source software other than the software licensed under the GPL and/or LGPL.

For the software categorized as (3) and (4), please refer to the terms and conditions of GPL-2.0 and LGPL-2.1, as the case may be at

<http://www.gnu.org/licenses/old-licenses/gpl-2.0.html> and
<http://www.gnu.org/licenses/old-licenses/lgpl-2.1.html>

The GPL/LGPL software is distributed in the hope that it will be useful, but WITHOUT ANY WARRANTY, without even the implied warranty of MERCHANTABILITY or FITNESS FOR A PARTICULAR PURPOSE.

At least three (3) years from delivery of products, Panasonic will give to any third party who contact us at the contact information provided below, for a charge no more than our cost of physically performing source code distribution, a complete machine-readable copy of the corresponding source code and the copyright notice, covered under GPL-2.0/LGPL-2.1.

Contact Information

oss-cd-request@gg.jp.panasonic.com

For the software categorized as (5) includes as follows.

- 1. The software developed by the OpenSSL Project for use in the OpenSSL Toolkit. (<http://www.openssl.org/>)
- 2. The software developed by the University of California, Berkeley and its contributors.
- 3. FreeType code.
- 4. The Independent JPEG Group's JPEG software.
- 5. tthttpd code.

Information for Users on Collection and Disposal of Old Equipment and used Batteries



These symbols on the products, packaging, and/or accompanying documents mean that used electrical and electronic products and batteries should not be mixed with general household waste. For proper treatment, recovery and recycling of old products and used batteries, please take them to applicable collection points, in accordance with your national legislation and the Directives 2002/96/EC and 2006/66/EC.



By disposing of these products and batteries correctly, you will help to save valuable resources and prevent any potential negative effects on human health and the environment which could otherwise arise from inappropriate waste handling.

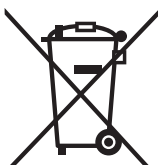

For more information about collection and recycling of old products and batteries, please contact your local municipality, your waste disposal service or the point of sale where you purchased the items. Penalties may be applicable for incorrect disposal of this waste, in accordance with national legislation.

For business users in the European Union

If you wish to discard electrical and electronic equipment, please contact your dealer or supplier for further information.



[Information on Disposal in other Countries outside the European Union]

These symbols are only valid in the European Union. If you wish to discard these items, please contact your local authorities or dealer and ask for the correct method of disposal.

Note for the battery symbol (bottom two symbol examples):

Cd

This symbol might be used in combination with a chemical symbol. In this case it complies with the requirement set by the Directive for the chemical involved.

Customer's Record

The model number and serial number of this product can be found on its rear panel. You should note this serial number in the space provided below and retain this book, plus your purchase receipt, as a permanent record of your purchase to aid in identification in the event of theft or loss, and for Warranty Service purposes.

Model Number _____

Serial Number _____

Panasonic Corporation

Web Site : <http://panasonic.net>

© Panasonic Corporation 2013