



www.wunder.it

WEIGHING PLATFORM WHEELCHAIR
MOD. RW(WU150)

INSTRUCTION MANUAL



Read this manual carefully before using the instrument

INDEX

Table with 3 columns: Index number, Description, and Page number. Includes entries for General Rules, Safety, Technical Specification, Indicator, Installation, Instruction for Use, Printer Functions, Setting Setup, Error Message, Maintenance and Assistance, Conformity, Identification Labels, Scrapping and Waste Disposal, and Warranty.



By choosing the WUNDER mod. RW (WU150) professional electronic scale, you have purchased a high precision instrument.

Since over 40 years Wunder has placed its experience at the service of health. This instrument is compliant with national standards in hospitals and clinics with medical class I with measurement function and is calibrated in conformity with accuracy class III.

The instrument is characterised by the possibility of fixing the electronic terminal to the weighing platform by means of a column or else installing the terminal autonomously.

The instrument is equipped with a dual LCD electronic terminal with triple reading to simultaneously view Weight, Height, and BMI

2. GENERAL RULES

!Carefully read this manual before using the instrument as it supplies important indications concerning OPERATING SAFETY AND MAINTENANCE.

The descriptions and illustrations supplied in this manual are not binding.

WUNDER reserves the right to modify its products as deemed convenient in order to approve them without being committed to update this publication.

Conventions:

The following symbols have been used in this manual:



0470 MEDICAL CERTIFICATION



METROLOGICAL CERTIFICATION AND APPROVAL FOR MEDICAL USE



ACCURACY CLASS



ASSISTANCE WARRANTY CERTIFICATE



ATTENTION!
PLACED BEFORE DETERMINING PROCEDURES. COMPLIANCE FAILURE CAN DAMAGE THE PRODUCT



WARNING!
PLACED BEFORE DETERMINING PROCEDURES. COMPLIANCE FAILURE CAN HARM THE OPERATOR OR PATIENT OR DAMAGE THE PRODUCT



WASTE DISPOSAL



TYPE B PARTS SUPPLIED



BATTERY POWER



INDICATION OF WEIGHT FUNCTIONALITY

INDICATION OF STABLE WEIGHT



INTERFERENCE COULD OCCUR NEAR THE APPLIANCES



DUAL INSULATION



3. SAFETY



WARNINGS!

Operators must read this manual carefully, comply with the instructions it contains and become familiar with the correct use and maintenance procedures of the instrument.

- Retain this manual for consultation and as a help in staff training
- Do not overload the instrument beyond its maximum capacity
- Do not apply loads abruptly.
- Do not press the keys with sharp or pointed objects
- Do not try to open the instrument.
- Do not remove seals from the instrument.
- Do not short-circuit the battery terminals
- Use only the power supply provided by Wunder. Before using it, make sure that the local mains voltage is compatible with the voltage of the adapter shown on the identification plate
- Regularly check the integrity of the instrument's power cord and make sure it does not come in contact with hot appliances
- Make sure that the power cord does not create obstruction hazards
- Unplug the instrument before cleaning it
- Do not place the instrument in water or other liquids
- Perform maintenance and subsequent metric verifications regularly

4. TECHNICAL SPECIFICATION

Model	RW 02
Capacity	300kg x 100g
OIML Approval	Classe III
Weighing Unit	Kg
LCD Display	LCD 20mm con 5 digits + second LDC for Height and BMI
Key Functions	ON/ZERO/OFF, HOLD/BMI, TARA, PRINT, MEMORY
Power Supply	Adapter 12V 2A; Rechargeable battery pack
Operation Temperature	5°C / 35°C



5. INDICATOR

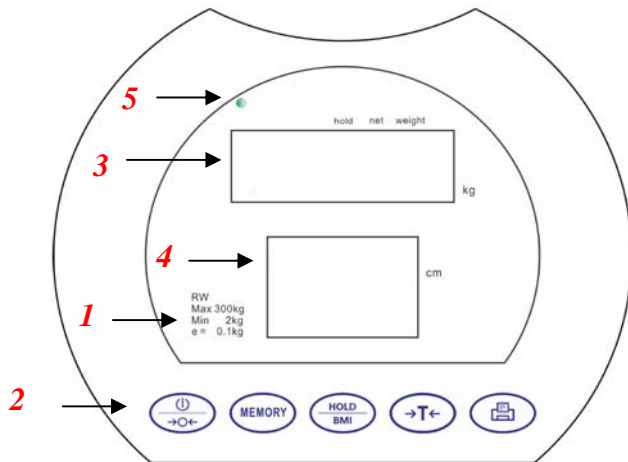

1. Weighing Capacity and division
2. Key Functions
3. Main display
4. Second display height/ BMI
5. Power indication

5.1 Key function

Key	Description
	Turn ON the scale, long press 3sec to turn off the scale.
	To reset the display to 0.0kg display / Zero the scale ($\pm 2\%$ of full capacity)
	To hold weighing result on the display / determine stable weighing value. Long press 3sec to determine the Body Mass Index (BMI).
	Tare un-wanted weight.
	To store 5 pre-tare values.
	Print out data.

5.2 Display

Zero symbol

- Stable symbol: To indicate that the weight is stable.
- Minor weight: Weight under zero.
- Zero symbol: Weight is at zero point.
- Low battery: Battery need to charge or replaced..

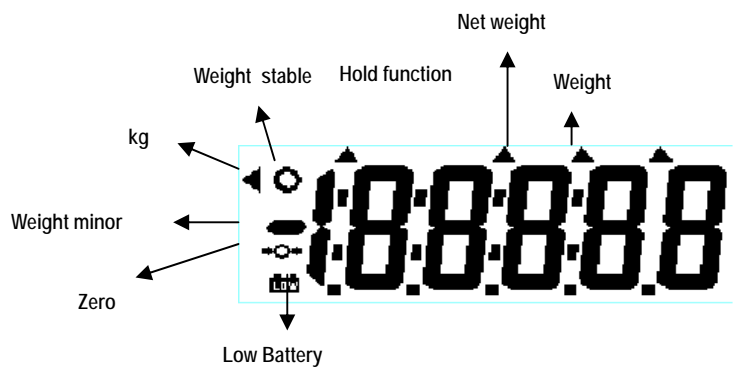

6. INSTALLATION

After unpacking the unit, check the integrity and the submission of all components.

The instrument should be situated away from heat sources, in an environment free from excessive vibration and air currents.

The weighing platform must be placed on a flat, stable surface, and all the feet should rest on the ground.

Version standard with cable:

The instrument is ready for use

6.1 ASSEMBLY INSTRUCTION FOR THE OPTIONAL ACCESSORY

WALL MOUNTING BRACKET:

RW (150) Version with cable with wall support (optional included)

1.

Place the metal bracket to the wall and properly mark the holes. Insert dowels into the holes. Fix the wall support with screw included.

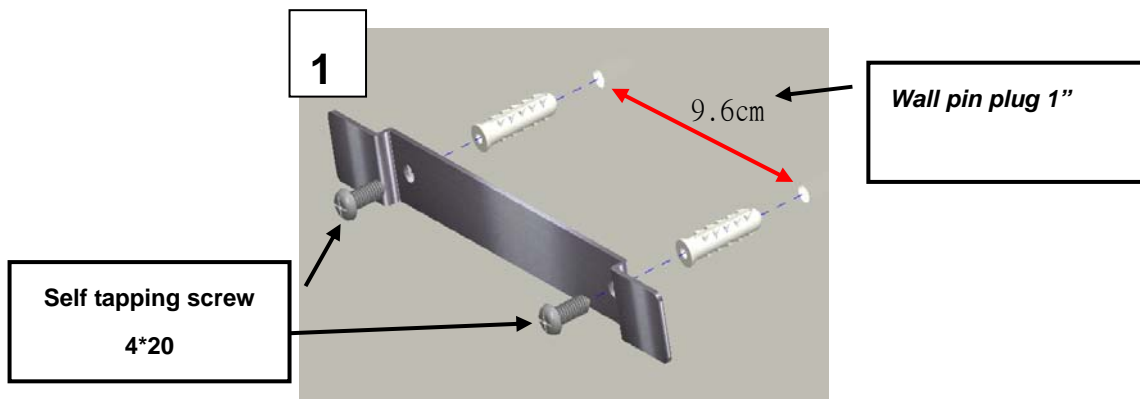

2. 3.

Fix the indicator support with screw included.

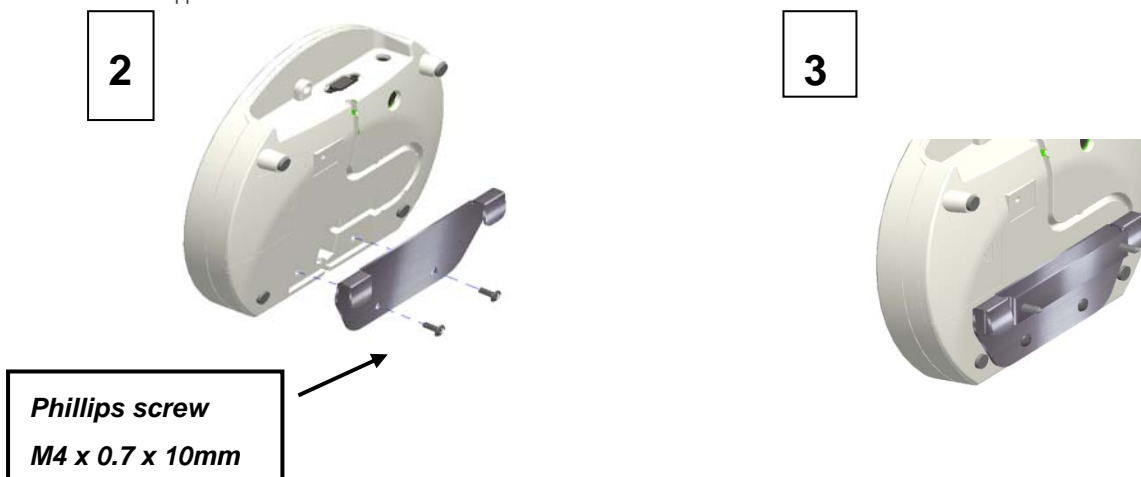

STAND FOR THE INDICATOR:

RW (150) Version stand display (optional not included only request)

1. The user can decide to connect the cable inside or outside column.
2. Fix the display with screws included to the stand .

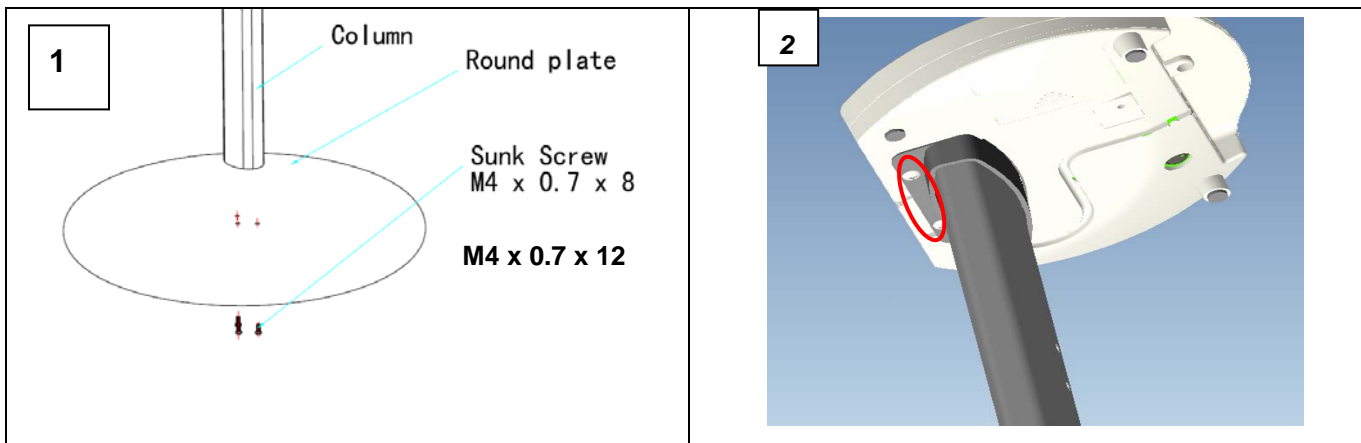

7. INSTRUCTION FOR USE

7.1 Time setting

Long press PRINT key for 3 seconds to enter the TIME SETTING mode, beginning with the top row, with the flashing digit. Press PRINT key after successful change to move to next step.

EX: To input Dec 25, 2008, 8:00am.

	<p>Enter year:Using TARE keys to decrease the value, press HOLD key to move to next digit. Press PRINT key after successful entry to move to next stage.</p>
	<p>Enter date:Using TARE keys to decrease the value, press HOLD key to move to next digit. Press PRINT key after successful entry to move to next stage.</p>
	<p>Enter time: Using TARE keys to decrease the value, press HOLD key to move to next digit. Press PRINT key after successful setting.</p>
	<p>Display Format YYYY→MM.DD→TT:SS</p>

7.2 Instruction for charging and connecting

If **Lo** prompt displays on the LCD, please charge the scale with exclusive adaptor.

Locate adaptor plug on the rear side of indicator.

The battery should be recharged at least every 3 months regardless if it is used or not. After a long period in storage, e.g. over 3 months, the battery should run a full cycle (charge/discharge) to allow it to restore to full capacity.

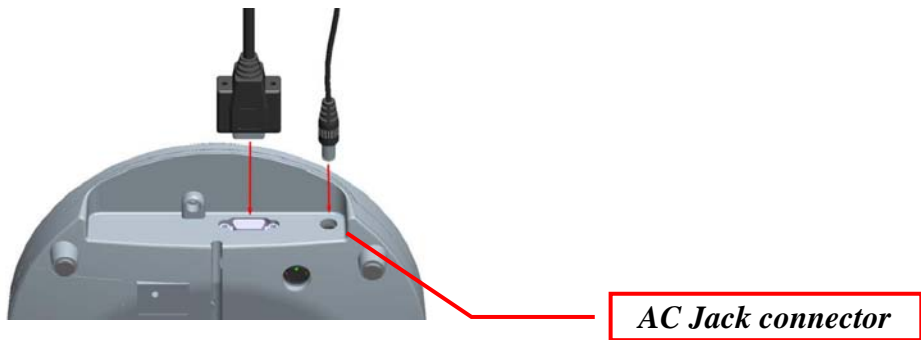

7.3. Instruction for replacing batteries

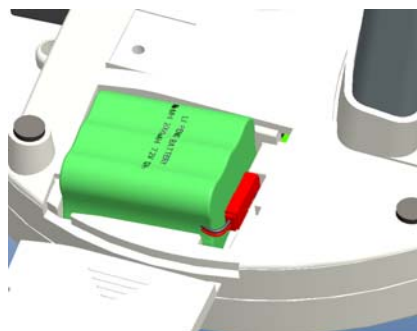
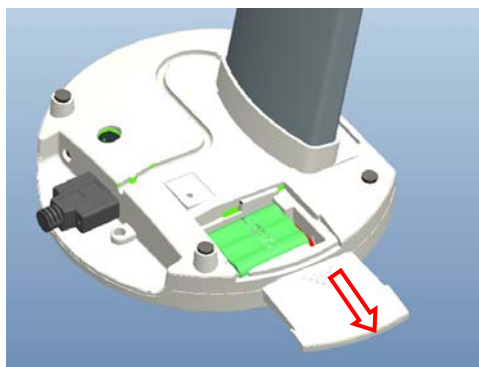

1. Open the battery cover, and take the battery out.
2. Disconnect the rechargeable battery pack then replace it by a new one. Put the battery back then arrange the connector in place well.

7.4. Weighing

Switch on the scale using  key. The diagnostic scale self-check is performed and the software version is displayed.

The „0,00 kg” weight displays on the screen, now the scale is ready for weighing.

Note: If display is not at 0.0kg while switching power on. Kindly press  key to zero the scale which can be used at any time to zero the

7.5. Hold function

The scale is provided with the integrated hold function to determine the average weight. It enables people to be weighed accurately although they are not still on the scale platform.

- Switch 'ON' the scale using [ON/ZERO/OFF] key. The diagnostic self-check will be performed and after that „0.0 kg” will display on the screen with 'stable' and 'zero sign'.
- Move the object/ person on the scale platform.
- Press the [HOLD/BMI] key once. The 'HOLD' will display on the screen with blinking triangle and after few seconds the average of fluctuating weight will display on the screen and will lock on the display.
- To release the locked weight on display simply press the [HOLD/BMI] key again and the display will return to normal mode automatically.

[HOLD/BMI] key function can be activated before or after putting the weight on the tread platform. But in case of weighing unstable person it is recommended to press [HOLD/BMI] key after the person moves on the tread platform.

7.6. BMI function

In normal mode, long press [HOLD/BMI] key 3sec to enter into BMI mode.

The second display will show last height and the extreme left digit will blink.

Use [TARE] to decrease value and press [HOLD] to change to next digit. Press [ON/ZERO/OFF] key to confirm height value.

When the display shows "Hold", please stand on the scale platform, Proceed to weigh as normal. The instrument will show the weight, height, and BMI value.

To release the locked weight on display simply press the [HOLD/BMI] key again and the display will return to normal mode automatically.

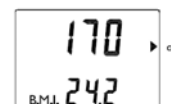

7.7. Tare function

Tare allows the user to zero the instrument to cancel the weight of a container/ clothes from the reading of the instrument, thus giving the true weight of the product/ person being tested.

Turn on the scale using  key.

When  displays on the screen and scale beeps twice, Place the object (clothes) need to be tare on the tread platform.

Press  after the weight stabilizes and stable sign appears on the display.

Display will return to 

Place the item/ baby need to be weighed (without removing the tare object). The weighing result is the Net weight of the item / baby.

To delete the saved tare value, remove the tare object from the tray and press  key again.

7.8. Pretare function

The scale can store 5 sets of pre-tare weight. To use dead weight to store pre-tare value at

m1 (memory 1) ~ m5 (memory 5) as below:

Using Dead Weight:

DESCRIPTION

EXAMPLE

Press "MEMORY" key after loading the weight on the platform; the display shows blinking "mX" sign (ex. m1)



Press "TARA" key to address the memory. (m1 ~ m5)



Press "ZERO" key to store the pre-tare weight; the instrument will be sounding "beep".

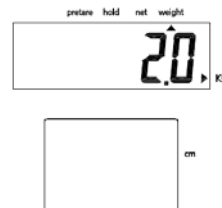

7.9. Recall Pre-Tare Weight

DESCRIPTION

EXAMPLE

Long press "MEMORY" key for 3 seconds; the display will show pre-tare weight of m5 first. The pre-tare weight will blink and a annunciator under "pretare" will be turned on.



Press "TARA" key till the intended memory of pre-tare weight displayed.

Press "ZERO" key to confirm the pre-tare weight to be used; the instrument will automatically perform tare function.



Press "MEMORY" key, return to Weighing Mode. Pretare annunciator will be turned off.



8. PRINTING FUNCTION

Weight can be printed for records using RS232 interface cable.

After weighing simply press PRINT key to print out the results.

The format presented below is the standard format of results print-out and cannot be changed.

Parameters of RS232 interface

Seriale RS232

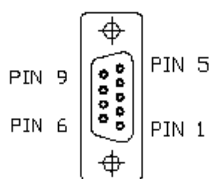

Connector RS232

WUNDER	
Date/Month/Year	hour:minute
Peso/Weight	30.00kg
Altezza/ Height	0.0cm
Indice Massa Corporea MI(Body Mass Index)	N/A
Sottopeso <u>Underweight</u>	<18
Normopeso <u>Normal weight</u>	18-24.9
Sovrappeso <u>Pre-obesity</u>	25-29.9
Obesità calaae I <u>Obesity class I</u>	30-34.9
Obesità calaae II <u>Obesity class II</u>	35-39.9
Obesità calaae III <u>Obesity class III</u>	>40

Connecting with PC

Start Hyper Terminal program from clicking

Start Menu → Programs → Accessories → Communication → Hyper Terminal.

1. New Connection Description

Give new connection a name then click OK.

2. Select Your COM Port

Click Connect to select your COM port. Usually there's only one option for select. Then click OK.

3. Port Settings

Click Bits per second to set up rate at 9600, Data bits at 8, Parity at None, Stop bits at 1 and Flow control at Hardware. Then click OK to complete your setting.

4. Output Data

When press the PRINT key to output data from scale to PC or an

Pin	Signal
2	TX
3	RX
5	GND

9. SETTING SETUP

Switch ON the scale and long press  key for 3 seconds, first "SETUP" and then "A.OFF" will display successively.

AUTO-OFF TIME SETUP

This enables operator to select the auto turn OFF time of the device.

BUZZER ON/OFF SETUP





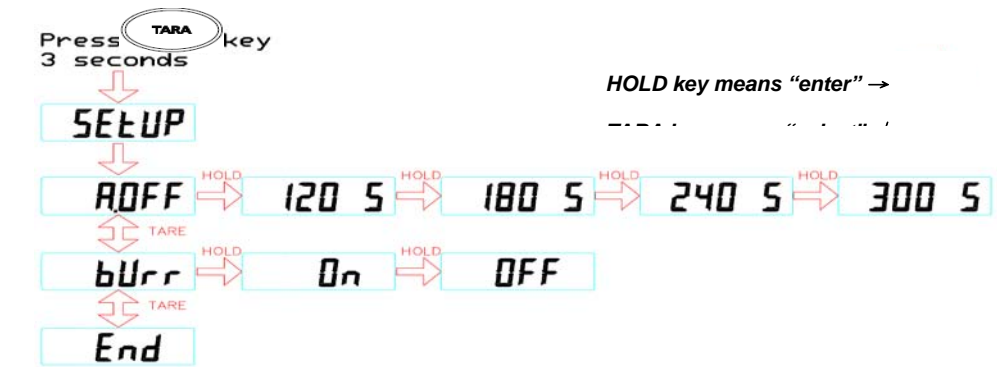

This enables operator to select beep sound ON/OFF.

Auto off time: 120 sec/180 sec/240 sec/300 sec/off Buzzer: On/Off

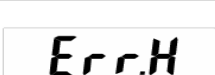

Note: To confirm the settings, please press  when **End** displays on the display.

10. ERROR MESSAGE

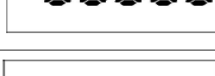
ERROR MESSAGE	REASON	ACTION
	Low Battery: This warning shows that the voltage of battery is too low to use	Please replace a new battery or plug the AC adaptor for operation.
	Overload: The total load exceeds the maximum capacity of scale	Please reduce the loading and try again.
	Counting error (too high): Indicates that the signal from the load cell/s is too height	This error is normally caused by a serious fault on the scales such as a faulty load cell or wiring. Please contact the local service representative.
	Counting error (too low): Indicates that the signal from the load cell/s is too low	This error is normally caused by a serious fault on the scales such as a faulty load cell or wiring. Please contact the local service representative.
	Zero count over calibration zero range +10% while power on	Please re-calibrate the instrument.
	Zero count under calibration zero range -10% while power on	Please re-calibrate the instrument.
	EEPROM Error: Indicates that there is a fault with the scales software	This error is normally caused by a serious fault on the scales such as a faulty load cell or wiring. Please contact the local service representative.

11. MAINTENANCE AND ASSISTANCE

Cleaning the instrument must be done with a soft cloth dampened with water or neutral detergent, avoiding the 'use of solvents or abrasives.

During transportation, be careful not to subject the instrument to excessive physical shock or mechanical stress. In case of repair or service, contact your dealer

12. CONFORMITY

WEIGHING INSTRUMENT DIGITAL WUNDER: RW(WU150) MODEL SERIAL NUMBER.....

This is to certify that this instrument has been tested and has passed the functional test. Meets the following standards:

EN 45501 / EN60601-1-2 / EN60601-1
93/42/EEC – Medical Devices Directive



13.IDENTIFICATION LABELS

<p>WUNDER SA.BI. srl  RW (WU 150) Max 300 kg DK 0199.336 e= 100 g Matr. 0081 T= -300 kg 5°C / 35°C</p>	<p>RW VANO BATTERIE Per la sostituzione della batteria (modello ricaricabile tipo :RETC 7,2 V 2000 mAh vedere il manuale di istruzioni) To replace the battery (rechargeable sealed type :RETC 7,2 V 2000 mAh see the manual)</p>
<p>Temperatura di stoccaggio: 0-60°C Storage Conditions Temperature :0-60°C</p> <p>RW stoccaggio</p>	<p>WUNDER Sa.Bi. S.r.L Model : RW (W150) 12V 2A Internally powered equipment with battery or supplied by external model AD-8057 (DK) Internamente alimentata con batteria o da AC/DC alimentatore esterno modello AD-8057 (DK)</p> <p>SER. NR.</p>
<p>CONFORME ALLA DIRETTIVA 93/42 CEE</p> <p>CE 0470</p>	

14. SCRAPPING AND WASTE DISPOSAL

Disposal  EU 2002/96/EC

This product complies with EU Directive 2002/96/EC. The crossed-bin symbol on the appliance indicates that the product at the end of its useful life, should be disposed of separately from household waste, must be completed in a recycling center for electrical and electronic equipment, or returned to the dealer at the time of 'purchase of a replacement. You are responsible for taking the appliance at the end of life at an appropriate collection facility. Appropriate separate collection to start the device resigned to recycling, treatment and environmentally compatible disposal contributes to avoiding possible negative effects on the environment and on the health and promote the recycling of materials of which the product is composed.

For more detailed information covering the collection systems available contact your local waste disposal service or the shop where the product was purchased.

As a consumer you are legally obliged to return used batteries or empty. You can deposit your old batteries at public collection points in your town, or you can place them at any dealer of different kind of batteries that have positioned the bins provided. Even in the case of 'destruction' of electrical and electronic equipment must be removed and stored in special containers.

NOTE: The following symbols are to indicate the presence of harmful substances

Batteries:

Pb Pb = Batteries containing Lead

Cd Cd = Batteries containing Cadmium

Hg Hg = Batteries containing Mercury



Do not dispose of electrical parts and batteries in household waste. Dispose of the battery through collection centers near you.



15. WARRANTY

This certificate must be kept until the warranty has expired.

It must be presented together with the invoice, tax receipt or delivery note providing the name of the dealer and date of purchase whenever a technical intervention is required. Otherwise the user will lose any warranty rights.

The warranty takes effect from the date of purchase and is valid during the entire period foreseen by the current catalogue/pricelist.

By warranty we mean the replacement or repair free of charge of parts making up the appliance which, at the discretion of the manufacturer, are deemed faulty from the origin; Wunder therefore has the faculty of repairing or replacing the item.

The warranty does not cover:

- shipping faults, damage caused by falls, carelessness or tampering
- damage caused by incapability of using the appliance and of its improper use
- damage caused by an insufficient or inadequate electrical system or alterations resulting from environmental, climatic or other types of conditions
- damage due to incorrect installation of the appliance and repairs carried out by unauthorised personnel
- Interventions at home for convenience controls or presumed defects
- Routine maintenance and that which can be considered normal wear from use
- consumables such as: power supplies, batteries, keyboards, plates, wheels, heads, rolls, load cells faulty due to blows or overloads

Service can also be refused when the appliance has been changed or transformed in any way.

In case of interventions at one's home, the customer must pay the fixed fee; if however the appliance is repaired at an authorised Wunder Service Centre, expenses and relative travel risk are borne by the user.

Wunder will not be held liable for damage of any nature caused directly or indirectly to persons, animals or objects resulting from failure to comply with all the instructions indicated in this manual or anyway resulting from improper use.

The Court of Bergamo has jurisdiction in case of any dispute

