

GETTING STARTED: XL series Sewing Machines

XL5050NTC XL5060NTC XL5070NTC

To help you get started, please follow these simple instructions in the order shown below. However, before you do so, read the safety instructions in the Instruction Manual.

Step 1

Unpack the sewing machine, and familiarise yourself with all the parts and controls that are mentioned in these instructions.

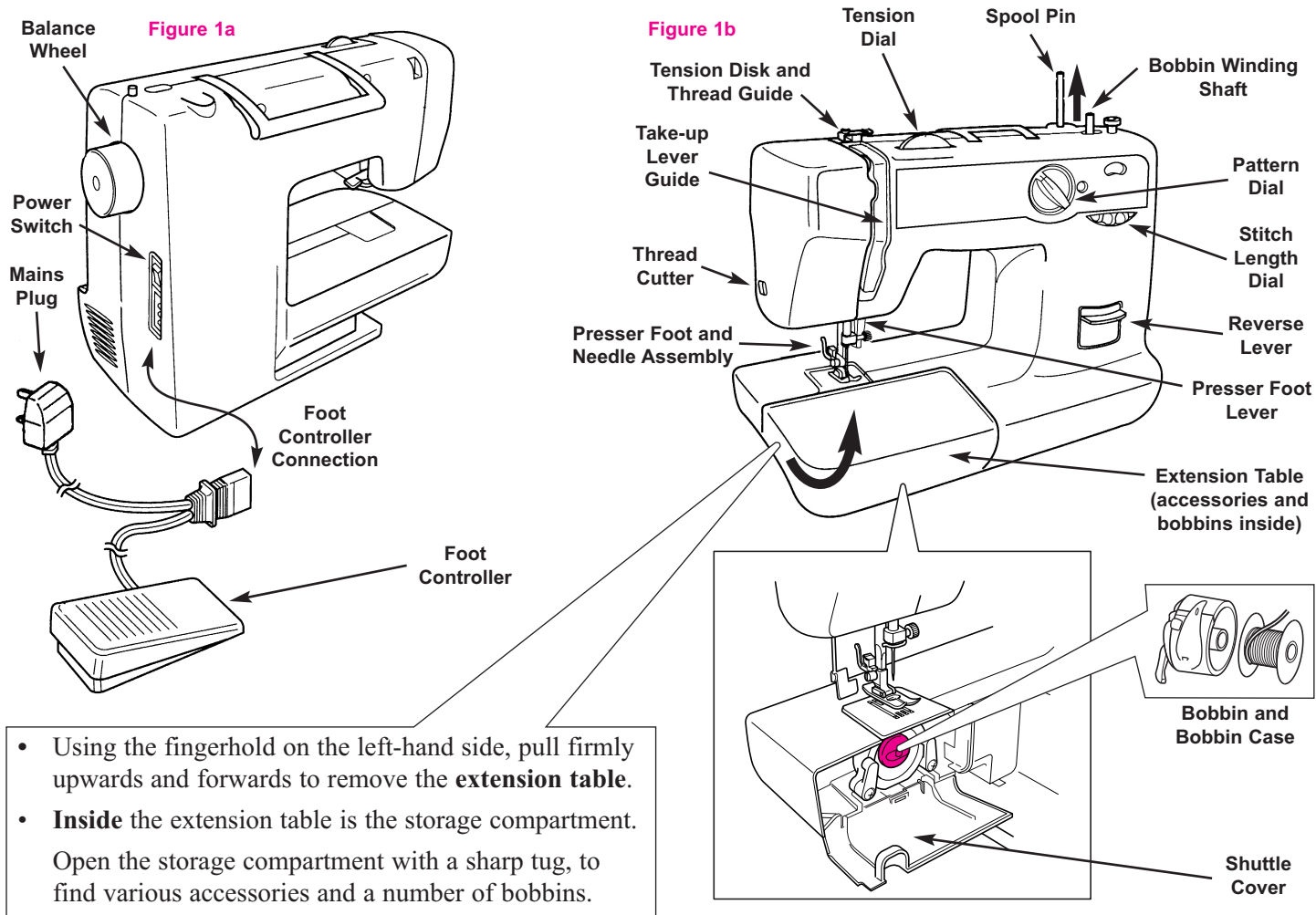

- Using the fingerhold on the left-hand side, pull firmly upwards and forwards to remove the **extension table**.
- Inside** the extension table is the storage compartment. Open the storage compartment with a sharp tug, to find various accessories and a number of bobbins.

Step 2

Prepare the sewing machine for use.

- Plug in the **foot controller connector** at the right hand side of the machine, as shown in **figure 1a**. Connect the **mains plug** into a wall socket, and place the controller on the floor. Grip the top of the **spool pin**, and pull it upwards as shown in **figure 1b** until it clicks into place at a height of about 50 mm (2 in). **Be careful not to pull the pin off the machine.** Set the **tension dial** to **5**. Set the **pattern dial** to **straight stitch**. Set the **stitch length dial** to between **2** and **3**.

Step 3

Winding the bobbin. (Your machine may be supplied with a fully wound bobbin, but you may want to fill another bobbin with your own thread.)

- Set the **power switch** to on (I). Place a spool of thread on the **spool pin** (**figure 3a**). Unwind some thread and pass the thread around the **tension disk**.
- Take one of the bobbins from the accessory pack. Pass the thread through the hole in the bobbin from the inside. Clip the bobbin onto the **bobbin winding shaft**. Push the bobbin winding shaft firmly to the right until it clicks into place against the stop (**figure 3b**).
- Hold the end of the thread and press the foot controller to wind the thread around the bobbin a few times. Trim the excess thread (**figure 3c**), and continue winding until the winding shaft stops automatically.
- Push the bobbin winding shaft back to the left, cut the thread, and remove the bobbin from the shaft (**figure 3d**). Unwind the thread from the tension disk.

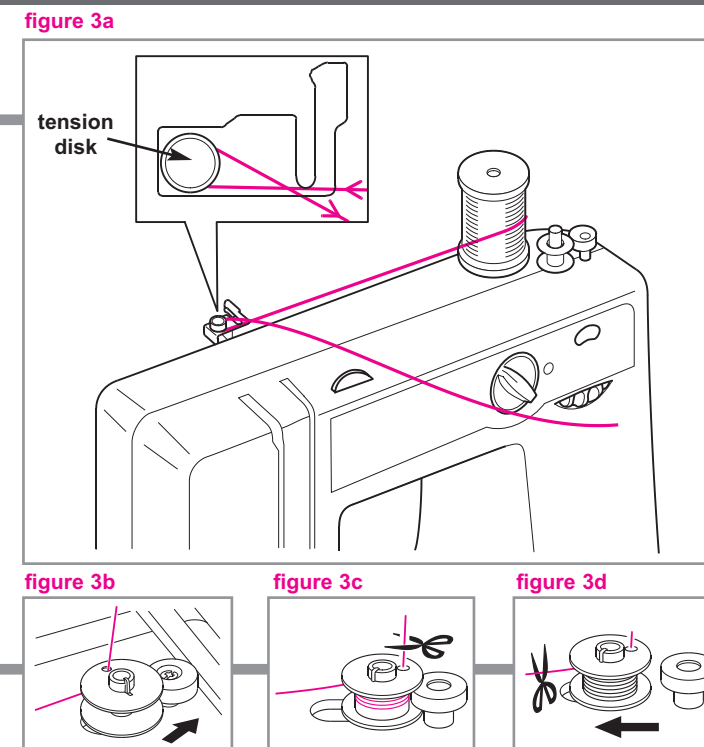

Step 4

Lower threading. (Your machine may be supplied with a threaded bobbin, but you may want to use another bobbin with your own thread.)

- Set the power switch to off (O). Raise the needle to its highest position by turning the **balance wheel** towards you (counter-clockwise). Open the **shuttle cover** behind the extension table.

- Remove the **bobbin case** from the shuttle, by pulling the **latch** (marked in red on **figure 4a**).
- Leaving about 10 cm (4 in) of thread trailing, insert the bobbin into the bobbin case (**figure 4b**).
- Hold the bobbin case in your left hand with the **bobbin case finger** pointing towards you (**figure 4c**). With your right hand, pull the trailing thread into the **slot** in the bobbin case (**figure 4c**).
- Draw the thread down under the spring into the **delivery eye** (**figure 4d**).

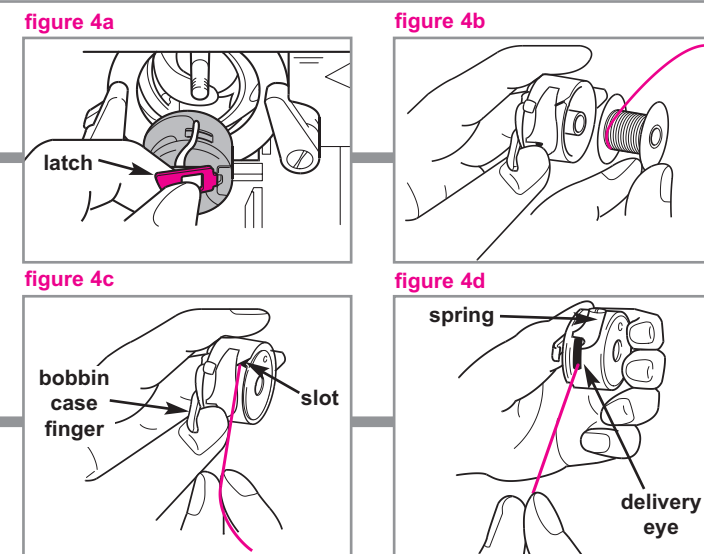

- Hold the bobbin case by the latch, with the finger pointing upwards (**figure 4e**). Insert the bobbin back into the shuttle, release the latch, and push the bobbin in until it clicks. *Make sure the bobbin case goes in all the way, or the latch will not hold the bobbin properly.* Leave the shuttle cover open.

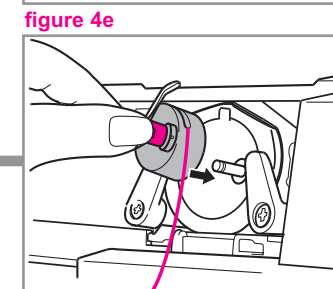

Step 5 Upper threading.

- Make sure the power switch is set to off (O).

Important: Raise the presser foot by pushing the **presser foot lever** upwards.
(see **figure 6a** in step 6 below)

Raise the **take-up lever** (just visible through the slot) to its highest position by turning the **balance wheel** towards you (counter-clockwise).

Place a spool of thread on the **spool pin** (**figure 5a**).

Unwind some thread and hook the thread around the back of the **thread guide**, making sure that the thread is not wound round the **tension disk**.

figure 5a

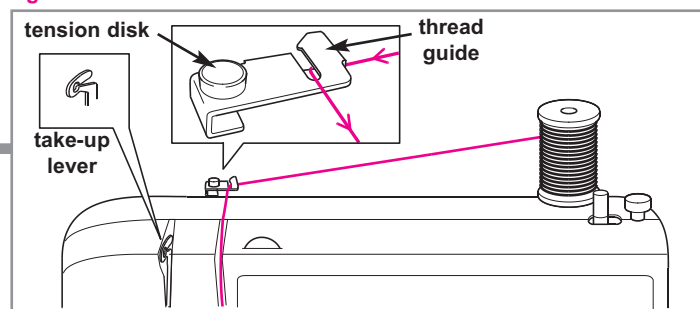

figure 5b

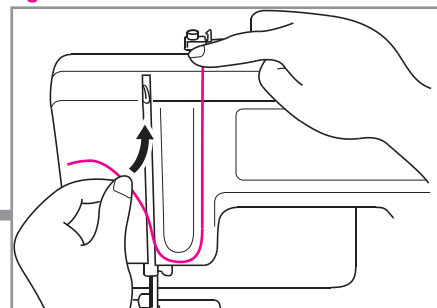

figure 5c

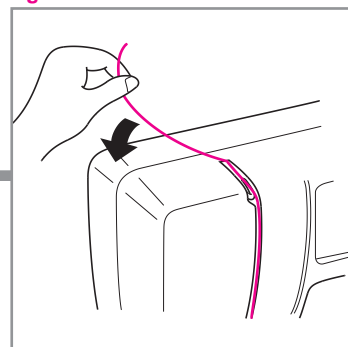
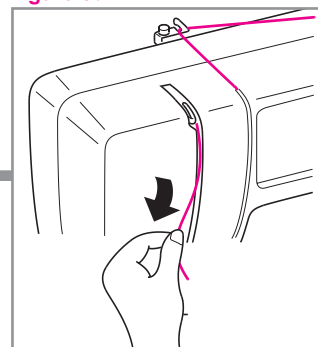

figure 5d



- Holding the thread at the top of the **take-up lever guide**, pass the thread down to the right of the guide, then under the guide and back up the left side (**figure 5b**).

- Pull the thread up the left of the take-up lever guide, and all the way to the back of the slot (**figure 5c**).
- Pull the thread over to the left, then back downwards again (**figure 5d**).

*This should hook the thread around the **take-up lever**, which is just visible inside the slot. If it does not, then try again.*

Step 6 Threading the needle.

- Make sure the power switch is set to off (O).

Raise the needle to its highest position by turning the balance wheel towards you (counter-clockwise).

Raise the presser foot by pushing the **presser foot lever** upwards (**figure 6a**).

- Pass the thread behind the needle guide, leaving about 10cm (4in) of thread trailing (**figure 6b**).

figure 6a

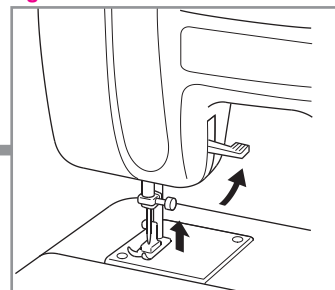

figure 6b

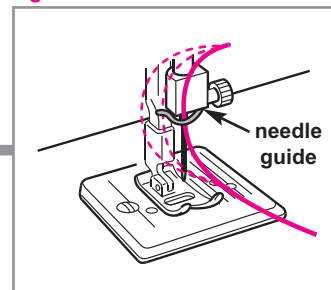

figure 6c

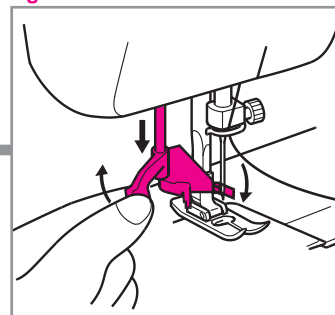
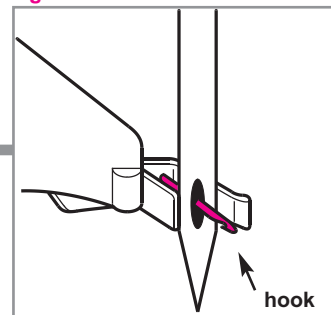

figure 6d



- *If your machine doesn't have a needle threader, then thread the needle by hand (from front to back), and go straight to Step 7.*

Needle threader:

- Pull the **needle threader** down and rotate it (**figure 6c**) so that the **hook** passes right through the eye of the needle from the back (**figure 6d**).

Step 6 continued

- Hook the thread around the **needle threader** and across the front of the needle, just below the **hook** (**figure 6e**).

figure 6e

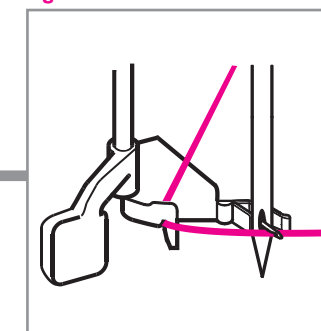
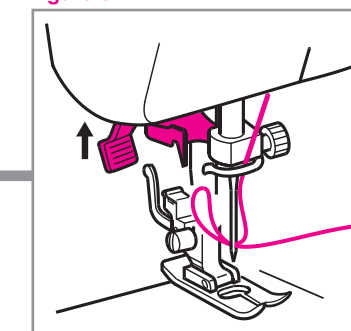

figure 6f



- Holding the thread loosely with your right hand, rotate the needle threader, so that the hook comes back out of the eye and the threader springs back upwards.

The hook should pull a loop of thread through the needle (**figure 6f**). *If it does not, then try again.*

- Pull the free end of the loop to draw the thread all the way out through the back of the needle.

Step 7 Drawing up the thread from the bobbin.

- Make sure the power switch is set to off (O).

Raise the needle to its highest position by turning the balance wheel towards you (counter-clockwise).

Raise the presser foot by pushing the **presser foot lever** upwards (**figure 7a**).

- With your left hand, hold the end of the upper thread (**figure 7b**).

figure 7a

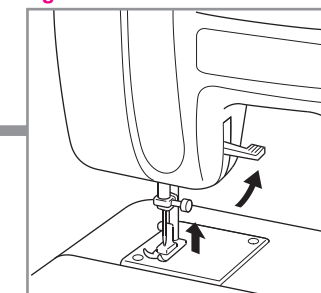
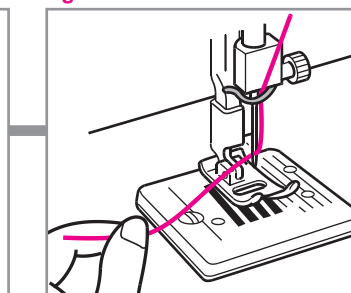

figure 7b



- With your right hand, turn the balance wheel towards you (counter-clockwise), so that the needle moves down and back up again to its highest position.

Pull the upper thread towards you, and the lower thread will come up from the bobbin in a small loop (**figure 7c**).

Pull the free end of the loop all the way out.

- Pull out both threads to about 15 cm (6 in), pass them between the toes of the foot, and out to the back of the machine, straight behind the foot (**figure 7d**).

Close the shuttle cover and refit the extension table.

figure 7c

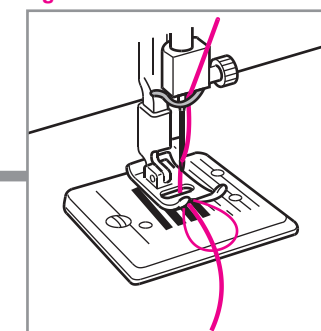
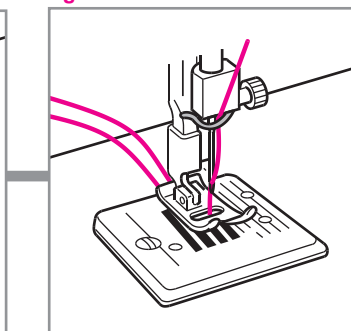

figure 7d



Starting to sew.

- Set the power switch to on (I).

Make sure the presser foot is up, and raise the needle to its highest position using the balance wheel.

Place the fabric under the foot with the needle about 1 cm (3/8 in) from the rear edge of the fabric, and lower the presser foot onto the fabric.

- To start sewing, press down on the foot controller.

To stop, release the foot controller.

To reverse sew, hold the **reverse lever** all the way down whilst sewing.

- When you have finished sewing, raise the presser foot and the needle.

Gently pull the fabric out, and cut the thread using the **thread cutter** (**figure 8**).

figure 8

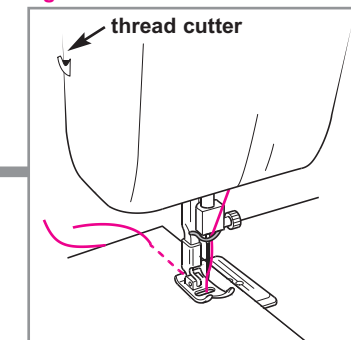

Step 6 continued over the page

To learn how to use the more advanced features of the XL series sewing machine, you should read the Instruction Manual.

For further assistance, phone: 0870 830 4020, email: support@brother-support.co.uk

or visit our website: www.brother-support.co.uk

Thank you for choosing a Brother product.