

---

# STANLEY

®

## MOUNTED HYDRAULIC DROP HAMMER

DH1500

DH3500

DH9000



## SAFETY, OPERATION AND MAINTENANCE USER'S MANUAL



© 2012 Stanley Black & Decker, Inc.  
New Britain, CT 06053  
U.S.A.  
67737 5/2013 Ver. 8

---

---

---

---

# TABLE OF CONTENTS

---

DECLARATION OF CONFORMITY .....	4
SAFETY SYMBOLS .....	5
SAFETY PRECAUTIONS.....	6
TOOL STICKERS & TAGS .....	9
OPERATION.....	10
PRE-INSTALLATION INSTRUCTIONS.....	10
SKIDSTEER, BACKHOE OR EXCAVATOR SIZE.....	10
TEST THE HYDRAULIC SYSTEM .....	10
HYDRAULICS .....	10
TOOL INSTALLATION.....	10
MOUNTING TO THE CARRIER.....	11
OPERATION .....	11
ADJUSTING IMPACT.....	12
MAINTENANCE .....	12
DAILY INSPECTION .....	12
MONTHLY CHECK.....	13
TRAVEL AND STORAGE.....	13
TROUBLESHOOTING .....	14
SPECIFICATIONS.....	15
DH1500 PARTS ILLUSTRATION .....	16
DH1500 PARTS LIST .....	17
DH3500 PARTS ILLUSTRATION .....	18
DH3500 PARTS LIST .....	19
DH9000 PARTS ILLUSTRATION .....	20
DH9000 PARTS LIST .....	21

## IMPORTANT

To fill out a Product Warranty Recording form, and for information on your warranty, visit [Stanleyhydraulic.com](http://Stanleyhydraulic.com) and select the Warranty tab.

(NOTE: The warranty recording form must be submitted to validate the warranty).

**SERVICING THE STANLEY HYDRAULIC DROP HAMMER.** This manual contains safety, operation, and routine maintenance instructions. Servicing of hydraulic tools, other than routine maintenance, must be performed by an authorized and certified dealer. Please read the following warning.

## WARNING

**SERIOUS INJURY OR DEATH COULD RESULT FROM THE IMPROPER REPAIR OR SERVICE OF THIS TOOL.**

**REPAIRS AND / OR SERVICE TO THIS TOOL MUST ONLY BE DONE BY AN AUTHORIZED AND CERTIFIED DEALER.**

**DECLARATION OF CONFORMITY  
ÜBEREINSTIMMUNGS-ERKLÄRUNG  
DECLARATION DE CONFORMITE CEE  
DECLARACION DE CONFORMIDAD  
DICHIARAZIONE DI CONFORMITA**



I, the undersigned:  
Ich, der Unterzeichnende:  
Je soussigné:  
El abajo firmante:  
Io sottoscritto:

**Weisbeck, Andy**

Surname and First names/Familiennamen und Vornamen/Nom et prénom/Nombre y apellido/Cognome e nome

**hereby declare that the equipment specified hereunder:  
bestätige hiermit, daß erklaren Produkt genannten Werk oder Gerät:  
déclare que l'équipement visé ci-dessous:  
Por la presente declaro que el equipo se especifica a continuación:  
Dichiaro che le apparecchiature specificate di seguito:**

1. Category: **Drop Hammer, Breaker**  
Kategorie:  
Catégorie:  
Categoria:  
Categoria:
2. Make/Marke/Marque/Marca/Marca **Stanley**
3. Type/Typ/Type/Tipo/Tipo: **DH1500, DH1501, DH1502, DH3500, DH9000, DH9001**
4. Serial number of equipment:  
Seriennummer des Geräts:  
Numéro de série de l'équipement:  
Numero de serie del equipo:  
Matricola dell'attrezzatura:

**All**

**Has been manufactured in conformity with  
Wurde hergestellt in Übereinstimmung mit  
Est fabriqué conformément  
Ha sido fabricado de acuerdo con  
E' stata costruita in conformità con**

Directive/Standards Richtlinie/Standards Directives/Normes Directriz/Los Normas Direttiva/Norme	No. Nr Numéro No n.	Approved body Prüfung durch Organisme agréé Aprobado Collaudato
EN ISO Machinery Directive EN ISO	982:2008 2006/42/EC:2006 12100-1, 12100-2:2009	Self Self Self

5. Special Provisions: **None**  
Spezielle Bestimmungen:  
Dispositions particulières:  
Provisiones especiales:  
Disposizioni speciali:
6. Representative in the Union: **Patrick Vervier, Stanley Dubuis 17-19, rue Jules Berthonneau-BP 3406 41034 Blois Cedex, France.**  
Vertreter in der Union/Représentant dans l'union/Representante en la Union/Rappresentante presso l'Unione

Done at/Ort/Fait à/Dado en/Fatto a Stanley Hydraulic Tools, Milwaukie, Oregon USA Date/Datum/le/Fecha/Data 1-10-11

Signature/Unterschrift/Signature/Firma/Firma

*Andy Weisbeck*

Position/Position/Fonction/Cargo/Posizione Engineering Manager

---

# SAFETY SYMBOLS

---

Safety symbols and signal words, as shown below, are used to emphasize all operator, maintenance and repair actions which, if not strictly followed, could result in a life-threatening situation, bodily injury or damage to equipment.



This is the safety alert symbol. It is used to alert you to potential personal injury hazards. Obey all safety messages that follow this symbol to avoid possible injury or death.



This safety alert and signal word indicate an imminently hazardous situation which, if not avoided, will result in death or serious injury.



This safety alert and signal word indicate a potentially hazardous situation which, if not avoided, could result in death or serious injury.



This safety alert and signal word indicate a potentially hazardous situation which, if not avoided, may result in minor or moderate injury.



This signal word indicates a potentially hazardous situation which, if not avoided, may result in property damage.



This signal word indicates a situation which, if not avoided, will result in damage to the equipment.



This signal word indicates a situation which, if not avoided, may result in damage to the equipment.

Always observe safety symbols. They are included for your safety and for the protection of the tool.

## LOCAL SAFETY REGULATIONS

Enter any local safety regulations here. Keep these instructions in an area accessible to the operator and maintenance personnel.

---

---

---

---

---

---

---

---

---

---

---

# SAFETY PRECAUTIONS

---

## **WARNING**

***Do not operate the tool unless the following safety instructions have been thoroughly read and understood! Read this manual before installing, operating or maintaining this equipment.***

A flying projectile from the tool, Rock or other material may enter the operator's compartment and cause serious or fatal injury to the operator. Personal protection equipment must be used.

A flying projectile from the tool  
Rock or other material may cause serious or fatal injury to bystanders. Never operate the tool when bystanders are in the work area.

On some machines/carriers, the tool can enter the operator's compartment if it breaks loose and swings toward the operator. Make sure that suitable impact shields are used when operating the Tool with this type of equipment.

Do not operate the tool unless all safety decals described in this manual are in place. The decals must be inspected periodically to ensure that all wording is legible. The decals must be replaced if illegible. Replacement decals can be obtained from your authorized Stanley Distributor.

When operating the tool you must use ear protection, eye protection, and breathing protection.

Exposure to silica dust during construction activities can cause serious or fatal respiratory disease. Use adequate respiratory protection.



**Read the Manual**



**Wear Breathing Protection**



**Wear Hearing Protection**



**Wear Eye Protection**

---

# SAFETY PRECAUTIONS

---



Tool operators and maintenance personnel must always comply with the safety precautions given in this manual and on the stickers and tags attached to the tool and hose.

These safety precautions are given for your safety. Review them carefully before operating the tool and before performing general maintenance or repairs.

Supervising personnel should develop additional precautions relating to the specific work area and local safety regulations. If so, place the added precautions in the space provided on page 5 in this manual.

The mounted hydraulic drop hammers will provide safe and dependable service if operated in accordance with the instructions given in this manual. Read and understand this manual and any stickers and tags attached to the tool and hoses before operation. Failure to do so could result in personal injury or equipment damage.

Check the rules and regulations at your location. The rules might include an employer's work safety program. Regulations may identify hazards such as working around utility supply lines or hazardous slopes.

## BE THOROUGHLY TRAINED BEFORE OPERATING THE UNIT ALONE

- Operator training must start in an area without bystanders and use all the controls until he/she can control the machine fully under the conditions of the work area.
- When learning to operate a machine, do so at a slow pace.

## KNOW THE WORK CONDITIONS

- The operator must know any prohibited uses or work areas for the machine. For example, excessive slopes and poor or dangerous terrain conditions must be avoided.

## OBEY SAFETY RULES

- Operate the tool in accordance with all laws and regulations which affect you, your equipment and the work-site.
- Do not operate the tool until you have read this manual and thoroughly understand all safety, operation and maintenance instructions.
- The operator must be familiar with all prohibited work areas such as excessive slopes and dangerous terrain conditions.
- Do not operate the tool until you have read the carrier equipment manual and thoroughly understand all safety, operation and maintenance instructions. The word "carrier", as used in this manual, means a skidsteer loader, backhoe or excavator used to operate the tool.
- Ensure that all maintenance procedures recommended in this manual are completed before using the equipment.
- **Warning:** Use of this tool on certain materials during demolition could generate dust potentially containing a variety of hazardous substances such as asbestos, silica or lead. Inhalation of dust containing these or other hazardous substances could result in serious injury, cancer or death. Protect yourself and those around you. Research and understand the materials you are cutting. Follow correct safety procedures and comply with all applicable national, state or provisional health and safety regulations relating to them, including, if appropriate arranging for the safe disposal of the materials by a qualified person.

---

# SAFETY PRECAUTIONS

---

- The operator must not operate the tool or carrier if any people are within the area where they may be injured by flying debris or movement of the equipment.
- Know the limits of your equipment.
- Establish a training program for all operators to ensure safe operation.
- Do not operate the tool unless thoroughly trained or under the supervision of an instructor.
- Become familiar with the carrier controls before operating the carrier and the tool.
- When operating the tool you must use ear protection, eye protection, and breathing protection.
- While learning to operate the tool and carrier, do so at a slow pace. If necessary, set the carrier mode selector to the slow position.
- Make sure all controls (levers and pedals) are in the NEUTRAL position before starting the carrier.
- While operating the tool and carrier, keep hands and feet on the controls at all times.
- Before leaving the carrier, always lower the boom and insure the carrier is stable. Never leave the machine with the engine running. ALWAYS ENGAGE THE PARKING BRAKE.
- Stop the engine before attempting to make any repairs, adjustments or servicing to either the carrier or the tool.
- Do not operate the tool at oil temperatures above 190°F/88°C. Operation at higher temperatures can damage the internal components of the equipment and will result in reduced performance.
- Do not operate a damaged, leaking, improperly adjusted, or incompletely assembled tool.
- Do not modify the tool in any manner.
- To avoid personal injury or equipment damage, all tool repair, maintenance and service must only be performed by authorized and properly trained personnel.
- If you do not understand how to safely operate your tool, contact an authorized Stanley Dealer for assistance.
- Keep this manual with the tool.
- Do not operate this equipment if you are taking medication which may affect your mental judgement or physical performance.
- Do not operate this equipment if you are under the influence of drugs or alcohol.
- Replace all faulty or leaking hydraulic hoses before further operation.
- After operation, hydraulic components may be hot enough to burn skin.



# TOOL STICKERS & TAGS

Refer to the Parts Illustration page in this manual for proper placement of stickers.



67768  
DH1500 Model Number Sticker

67735  
DH3500 Model Number Sticker

67780  
DH9000 Model Number Sticker



67791  
Drop Hammer Sticker

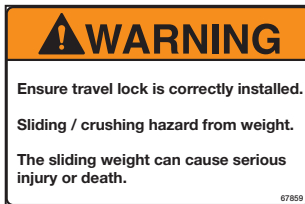

67859  
Travel Lock Sticker



67860  
Toppling & Crush Sticker



47351  
Composite Warning Sticker



67861  
Stability Sticker

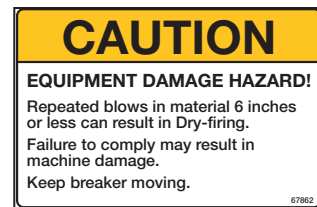

67862  
Equipment Damage Sticker

**Specification Plate**  
68641  
DH1500 CE Spec Plate  
  
68581  
DH3500 CE Spec Plate  
  
70982  
DH9000 CE Spec Plate

52539 (DH1500)  
Sound Power Level Sticker  
  
60917 (DH3500)  
Sound Power Level Sticker  
  
52539 (DH9000)  
Sound Power Level Sticker

# OPERATION

## PRE-INSTALLATION INSTRUCTIONS

### SKIDSTEER, BACKHOE OR EXCAVATOR SIZE

Check the Specifications section of this manual to determine correct carrier size, hydraulic flow and pressure requirements.

If hydraulic pressure, hydraulic back-pressure, hydraulic flow or excavator weight class are exceeded, the drop hammer warranty is void.

#### **WARNING**

Do not use bare hands to check or search for hydraulic leaks around hoses and fittings. Pinhole leaks can penetrate the skin. To inspect for leaks, depressurize the system, clean around suspected area, repressurize the system and visually check for leaks.

### TEST THE HYDRAULIC SYSTEM

1. Have your Stanley dealer test the carrier hydraulic system to make sure the system is operating at the manufacturers specified capacity and pressure ratings.
2. Be sure the fluid in the hydraulic system is clean.
3. Check the hydraulic filter. Replace the filter if dirty or deteriorated.
4. Have your Stanley dealer test the circuit to which the breaker will be connected to make sure that the circuit is supplying the specified flow and pressure rating for the breaker. See the Specifications section of this manual.

### HYDRAULICS

Some carriers may have flows above or below flow and pressure ranges required. Refer to Flow and Pressure Specifications on page 17 of this manual. If the flow is lower the drop hammer will simply cycle at a slower rate. If the flow rate is higher the control valve on the drop hammer will limit the flow to prevent the chain over-speeding and catching the weight as it drops.

Before connecting the drop hammer to the carrier hydraulic system; it is important to determine which are the pressure and tank lines of the carrier and connect the hoses appropriately. The pressure and tank lines are marked where they enter the valve block. If the hydraulics are connected incorrectly, the motor will rotate in the wrong direction. This will not damage the machine but it will not lift.

### TOOL INSTALLATION

#### **WARNING**

Do not lift or transport the drop hammer without the travel lock installed.

The hammer can move freely in the housing if the travel lock is not installed which can result in serious injury or death.

Ensure travel lock is installed.

The drop hammer may be lifted with a forklift through the mounting bracket or by feeding chains through the points shown in Figure 1 below. Always lift the drop hammer with machinery and lifting equipment that is rated to carry the weight of the machine.

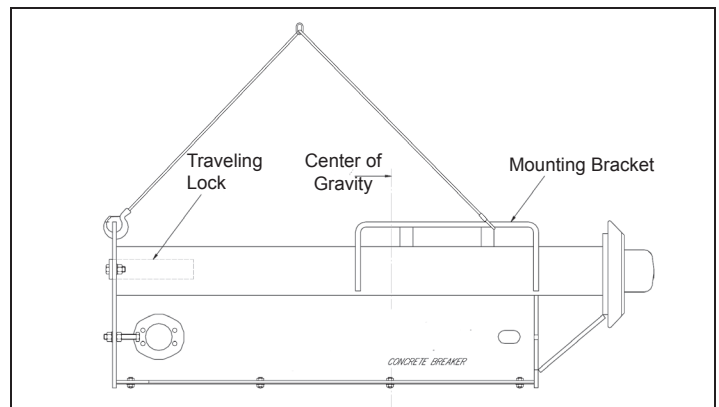

Figure 1. Lift Points

# OPERATION

## MOUNTING TO THE CARRIER

1. With the drop hammer laying on a flat level surface bolt the mounting plate to the mounting bracket. Ensure these bolts are torqued to the recommended value.

2. Bring the carrier up to the drop hammer from the bottom or impact end. If you have a quick attachment systems maneuver the mount plate on the carrier until it engages with the adaption plate. Then actuate the slides or levers to lock the plates together. With a pin mount system; maneuver the carrier until the pinholes are aligned and slide in the connection pins.

Ensure the pins are bolted in place. Grease these pivots as per the carrier manufactures recommendations. Never operate the drop hammer with a loose or ill-fitting attachment.

Connect the hoses to supply oil to the port marked "PRESS" on the valve block.

3. Carefully raise the drop hammer to the vertical position keeping the base of the machine close to the ground throughout the lifting movement. Slowly move the Cyclone through the full extent of rotation and lift to ensure no part of the machine or any hydraulic hosing foul the carrier arms or cylinders. Ensure hoses are long enough so they do not pull tight in any part of the rotation and short enough to stay clear of the ground or operating area.

4. Once the drop hammer is securely mounted to the carrier the Traveling Lock may be removed. Be sure to store this plate safely for future use.

During use, the traveling lock may be bolted outside the housing using the same hole as shown in Figure 2 below.

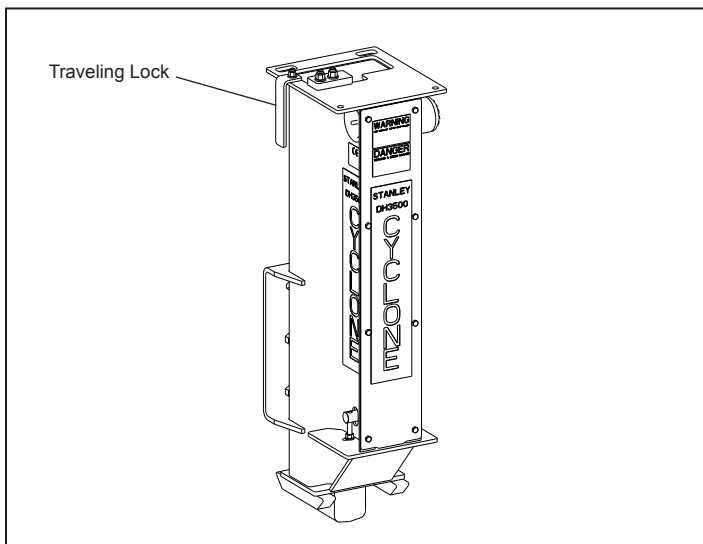

Figure 2. Traveling Lock

## OPERATION

### NOTICE

Failure to remove the travel lock may result in damage to the equipment during operation.

### WARNING

Exposure to silica dust during construction activities can cause serious or fatal respiratory disease. Use adequate respiratory protection.

### WARNING

#### KEEP CLEAR OF TOP OF DROP HAMMER

Impact Hazard

Contact with moving weight could result in serious injury or death.

67791

## OPERATION

Ensure that the drop hammer is operated at a safe distance from other personnel and equipment. Be sure all guards are in place.

The drop hammer's weight is normally rested on the skids during use. However when moving about the drop hammer may represent a heavy load for the carrier. Therefore care must be taken when moving about a job-site or when loading or unloading from a transporter. The drop hammer should be carried as low as possible and special care taken when negotiating uneven surfaces. Know the limits of your carrier.

### NOTICE

The drop hammer is intended for use only on level or near level surfaces. Do not operate the drop hammer on uneven or unlevel surfaces.

# OPERATION

## GENERAL TECHNIQUE FOR BREAKING SLAB

Rest the drop hammer in a vertical position on the concrete to be broken. The skids should be just resting on the concrete with some of the weight taken by the carrier. If a crack appears in the top surface of the concrete you can be sure it is broken all the way through.

Actuate the hydraulics and the drop hammer will start to cycle. As the concrete cracks or breaks move the carrier. It is best to move while the hammer is raised and pause momentarily as the hammer strikes.

Generally all that is required is to hit the concrete until it cracks and then move 6-12 inches /150-300 mm. Sitting in one place will pulverize the concrete and eventually the hammer will hit the column buffers. This is felt as a hard jarring action through the machine.

With skid steers movement can be in any direction but generally moving in a reverse direction provides the best control. On excavators setting the machine down and moving in arc with the slew drive is usually the quickest method.

It is important to keep the drop hammer as vertical as possible during operation as this provides the greatest impact.

When breaking thinner concrete, the drop hammer may hit too hard and punch completely through. In this instance the hammer sticking into the concrete and stopping the carrier traveling can slow production. If this occurs adjust the impact of the drop hammer as described below.

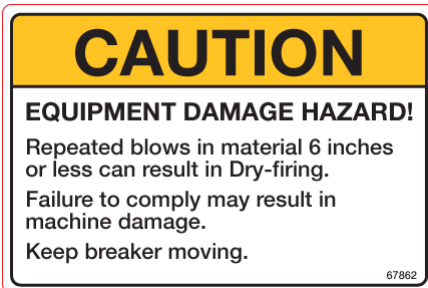

## ADJUSTING IMPACT

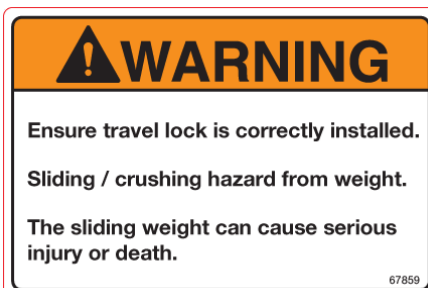

1. Tip the drop hammer to a horizontal position.
2. Gradually move the drop hammer past horizontal until the weight slides forward. This can be done in a controlled manner by shaking the weight out using the curl lever.
3. Allow the Hammer to slide out until it hits against the Safety Pin.
4. Return the drop hammer to horizontal and rest it on the ground and Shut the carrier off.
5. On the under-side of the Hammer remove the Bolt and Peg Locking Plate that hold the Hammer Peg.
6. Remove the Hammer Peg and replace it in the next hole. Tighten to 180 ft/lbs/240 Nm for the DH3500 and DH9000, for the DH1500 tighten to 140 ft lbs/190 Nm with the Bolt and Peg Locking Plate. See Figure 3 below.

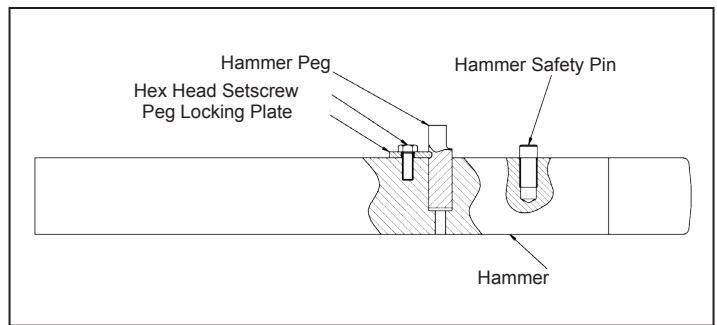

Figure 3. Hammer Adjustment

7. Restart the carrier and SLOWLY raise the drop hammer until the Hammer slides down the column.

## MAINTENANCE

It is recommended that only genuine Stanley parts are used. Genuine Stanley drop hammer parts are all checked for allowable tolerances.

Although the drop hammer is a simple machine, it is subject to severe stresses and shocks during normal operation. A five-minute daily check will ensure that your drop hammer remains in good condition and will prevent unscheduled down time.

## DAILY INSPECTION

Check that all the mount plate bolts that connect the drop hammer to the carrier are tight and torqued to the recommended value.

Check that the motor flange bolts are tight and secure.

# OPERATION

Check the chain adjustment bolts and secure the nuts if required.

Check the Housing Cover plate bolts and tighten if needed. Check the hydraulic hoses, fittings and valves for any leaks and repair as required.

With the machine turned off, oil the chain over the top sprocket with a heavy duty gear oil such as Mobil Gear 600 Series. Refer to the table below for recommended chain oil.

Ambient Temperature	Lubricant Rating (SAE)	Viscosity Grade (Hydraulic Fluid)
23° - 41°F / -5° - +5°C	20	46 - 68
41° - 104°F / 5° - 40°C	30	100
104° - 122°F / 40° - 50°C	40	150 - 220
122° - 140°F / 50° - 60°C	50	320

## MONTHLY CHECK

With the drop hammer in a vertical position and the carrier turned off remove the Housing Cover plate. Check the chain tension. The chain should move about 1/2 inch/10-15 mm at its center point. To adjust the chain, loosen the Tensioning Bolt lock nuts (Item 32 DH1500 or Item 30 DH3500) and the Clamp Nut (Items 41-42 DH1500 or Items 34-35 DH3500). Adjust the Tension Bolts evenly (so that the lower shaft/sprocket are kept parallel). See Figure 4 below.

**Note: In the first month of operation this should be done weekly until the chain beds in.**

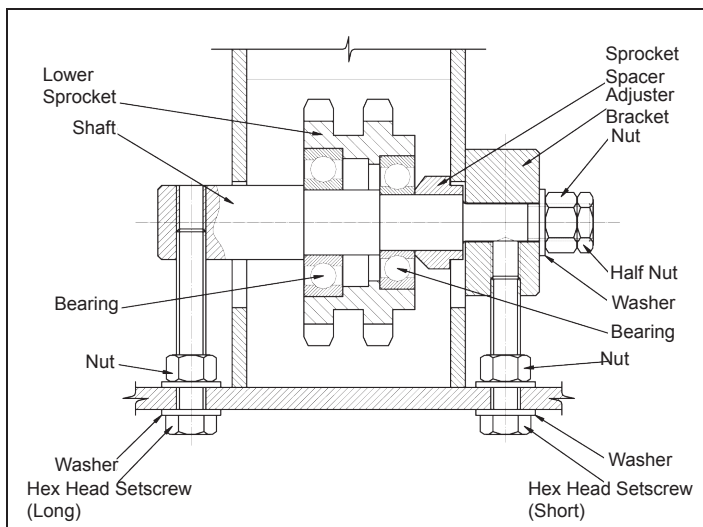

Figure 4. Lower Sprocket Assembly

Remove the rubber inspection cover at the top of the drop hammer and check the motor nut is tight. Replace the inspection cover.

Standing clear of the machine, start the drop hammer and SLOWLY rotate the chain until the chain Connecting Plate Assembly is accessible. Turn the carrier off and disconnect hydraulic hoses.

Check this assembly for signs of excessive wear, and replace as required.

Lubricate this assembly and the chain. Refer to the table on the previous page.

Replace the Housing Cover.

Tip the drop hammer forward and slide the weight out as described Adjusting Impact section of this manual.

Inspect the Hammer Connecting Pin and replace if excessively worn.

Liberal grease the Hammer Connecting Pin USE A LITHIUM BASED GREASE WITH NGLI 1 or 2 RATING (Mobilgrease HP or Shell Alvania EP) and replace the hammer as described in Adjusting Impact section of this manual.

It is worthwhile at this stage to dress the hammer tip and remove any excessive burring.

## TRAVEL AND STORAGE

1. Ensure the travel lock is installed before transporting the drop hammer.

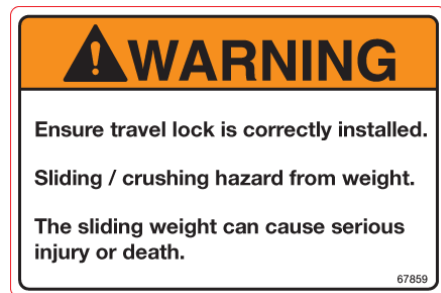

# TROUBLESHOOTING

This section describes how to find and resolve problems users may experience. If a situation occurs that is not covered, call your Stanley Customer Service representative for assistance.

## ⚠ WARNING

Inspecting the tool or installing parts with the hydraulic hoses connected can result in severe personal injury or equipment damage. To prevent accidental startup, disconnect the hydraulic power before beginning any inspection or installation task.

If symptoms of poor performance develop, the following chart can be used as a guide to correct the problem.

When diagnosing faults in operation of the tool, always check that the hydraulic power source is supplying the correct hydraulic flow and pressure to the tool as listed in the table below. Use a flowmeter known to be accurate. Check the flow with the hydraulic oil temperature at least 80° F/27° C.

PROBLEM	CAUSE	SOLUTION
Hammer will not fire.	Hydraulic flow is in wrong direction.	Reverse the flow.
	Low hydraulic oil level.	Fill reservoir.
	No flow to breaker.	Have hydraulic circuit tested by authorized dealer/distributor per approved procedure.
	Main relief set low.	
	Internal damage.	Have unit serviced by an authorized dealer/distributor.
	Damaged quick couplers.	Replace.
Hammer runs slowly.	Low hydraulic flow	Have hydraulic circuit tested by an authorized dealer/distributor per approved procedure.
	Internal leakage.	Have unit serviced by an authorized dealer/distributor.
Hammer runs erratically.	Damaged switch or connection.	Have carrier serviced by an authorized dealer/distributor.
	Relief set too low.	
	Internal damage.	
	Hammer binding.	Clean hammer in housing.
Hydraulic system overheats.	Chain tension too tight	Have unit serviced.
	Main relief set low.	Have unit serviced by an authorized dealer/distributor.
	Insufficient cooling capability in hydraulic circuit.	
	Line/hose size too small.	
	Excessive back-pressure.	

---

# SPECIFICATIONS

---

## DIMENSIONS AND WEIGHTS

### Weight w/o Mounting Bracket

DH1500 .....	700 lbs / 317.5 kg
DH3500 .....	1570 lbs / 712 kg
DH9000 .....	3100 lbs / 1406 kg

### Height

DH1500 .....	63.75 in. / 162 cm
DH3500 .....	65.5 in. / 166 cm
DH9000 .....	74.375 in. / 189 cm

### Hydraulic Pressure Range

DH1500 .....	2300-3000 psi / 159-207 bar
DH3500 .....	2350-3000 psi / 162-207 bar
DH9000 .....	2400-3000 psi / 166-207 bar

### Minimum Flow Range

DH1500 .....	8.7-20.6 gpm / 33-78 lpm
DH3500 .....	10.6-20.6 gpm / 40-78 lpm
DH9000 .....	20.6-31 gpm / 78-117 lpm

**Recommended Hose** ..... 5/8" Parker 451TC

**NOTE:** Weights, dimensions and operating specifications listed on this sheet are subject to change without notice. Where specifications are critical to your application, please consult the dealer.

# DH1500 PARTS ILLUSTRATION

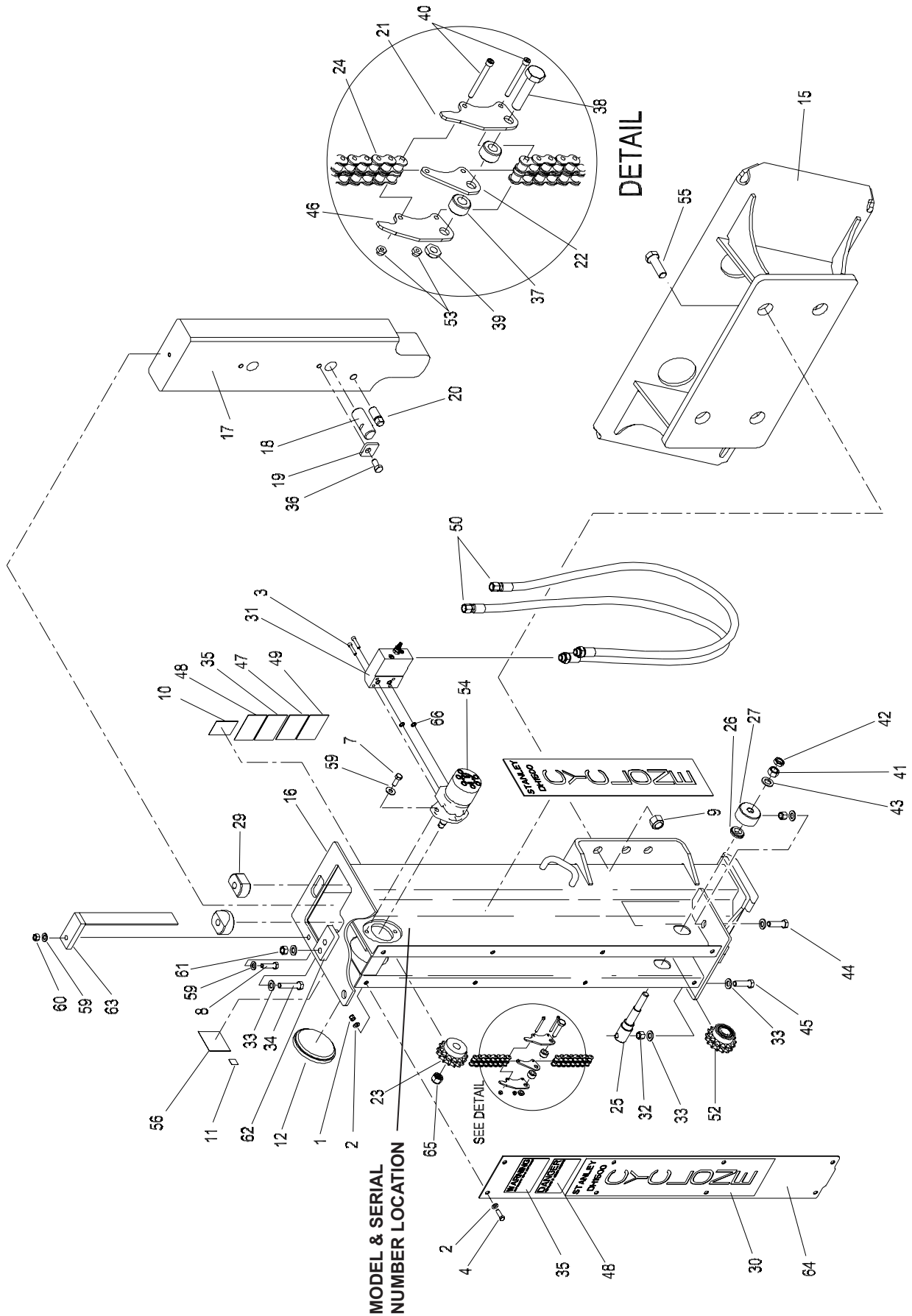



# DH1500 PARTS LIST

Item	SHT No.	Qty	Description
1	04353	8	NYLOCK NUT
2	04585	16	WASHER
3	06638	4	SHCS
4	07860	8	SHCS
7	20871	2	HHCS
8	20908	1	HHCS
9	44956	4	NYLOCK NUT
10	47351	1	DECAL, COMPOSITE WARNING
11	52539	1	SOUND POWER LEVEL
12	67709	1	INSPECTION COVER
15	69803	1	BRACKET WELDMENT
16	67740	1	HOUSING
17	67747	1	HAMMER MACHINING
18	67748	1	HAMMER PEG
19	67749	1	PEG LOCKING PLATE
20	67750	1	HAMMER SAFETY PIN
21	67751	1	RIGHT SIDE LIFT LUG
22	67752	1	CENTER LIFT LUG
23	67753	1	MOTOR SPROCKET
24	67754	1	CHAIN
25	67755	1	SHAFT CYCLONE
26	67756	1	SPROCKET SPACER
27	67757	1	ADJUSTER BRACKET
29	67767	2	POLY-BUSH
30	67768	3	DECAL, DH1500
31	69788	1	VALVE ASSEMBLY
32	67788	2	HEX NUT END
33	67789	6	WASHER
34	67790	2	HHCS
35	67791	2	DECAL, KEEP CLEAR OF HAMMER
36	67792	1	HHCS
37	67796	2	LIFT LUG SPACER
38	67797	1	HHCS
39	67798	1	FLEX LOCK NUT
40	67799	2	SHCS

Item	SHT No.	Qty	Description
41	67801	1	HEX NUT
42	67802	1	HEX JAM NUT
43	67803	1	WASHER
44	67804	1	HHCS
45	67820	1	HHCS
46	67852	1	LEFT SIDE LIFT LUG
47	67859	1	DECAL, TRAVEL LOCK
48	67860	2	DECAL, TOPPLING HAZARD
49	67861	1	DECAL, STABILITY HAZARD
50	67869	2	HOSE
51			NO ITEM
52	68023	1	LOWER SPROCKET ASSY
53	68340	2	FLEX LOCK NUT
54	68542	1	HYDRAULIC MOTOR
55	68578	4	HHCS
56	68641	1	CE SPECIFICATION PLATE
59	371050	3	WASHER
60	371500	1	NYLOCK NUT
61	371507	2	NYLOCK NUT
62	67746	1	HAMMER STOP
63	67742	1	TRAVELING LOCK
64	67741	1	HOUSING COVER
65	70788	1	NYLOCK NUT
66	00354	2	O-RING

# DH3500 PARTS ILLUSTRATION

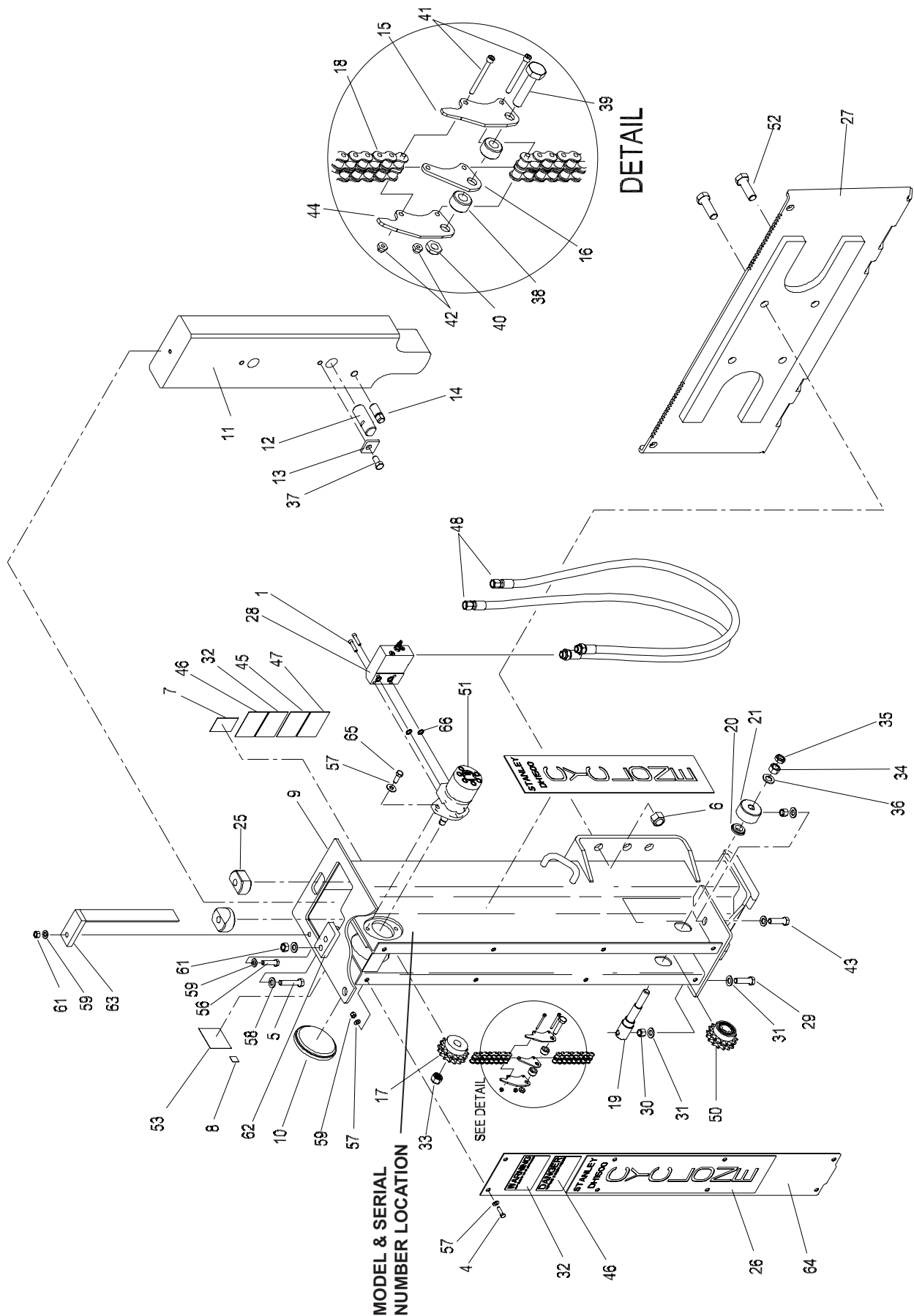

## DH3500 PARTS LIST

Item	SHT No.	Qty	Description
1	06638	4	HSHCS
4	20871	8	HHCS
5	23630	2	HHCS
6	44956	4	NYLOCK NUT
7	47351	1	DECAL, COMPOSITE WARNING
8	60917	1	SOUND POWER LEVEL
9	67703	1	HOUSING
10	67709	1	INSPECTION COVER
11	67710	1	HAMMER MACHINING
12	67711	1	HAMMER PEG
13	67712	1	PEG LOCKING PLATE
14	67713	1	HAMMER SAFETY PIN
15	67714	1	RIGHT SIDE LIFT LUG
16	67716	1	CENTER LIFT LUG
17	67717	1	MOTOR SPROCKET
18	67718	1	CHAIN
19	67719	1	SHAFT, CYCLONE
20	67720	1	SPROCKET SPACER
21	67721	1	ADJUSTER BRACKET
25	67734	2	POLY-BUSH
26	67735	3	DECAL, DH3500
27	67736	1	BRACKET WELDMENT
28	69789	1	VALVE ASSEMBLY
29	67787	1	HHCS
30	67788	2	HEX NUT
31	67789	5	WASHER
32	67791	2	DECAL, KEEP CLEAR OF HAMMER
33	67795	1	NYLOCK NUT, HOLDS SPROCKET TO MOTOR
34	67801	1	HEX NUT
35	67802	1	HEX JAM NUT
36	67803	1	WASHER
37	67808	1	HHCS
38	67809	2	LIFT LUG SPACER
39	67810	1	SCREW FOR SPACER
40	67811	1	NUT FOR SPACER

Item	SHT No.	Qty	Description
41	67812	2	SCREW FOR CHAIN
42	67813	2	CRIMP LOCK NUT
43	67820	1	HHCS
44	67853	1	LEFT SIDE LIFT LUG
45	67859	1	DECAL, TRAVEL LOCK
46	67860	2	DECAL, TOPPLING HAZARD
47	67861	1	DECAL, STABILITY HAZARD
48	67869	2	HOSE
49			NO ITEM
50	68024	1	LOWER SPROCKET ASSY
51	68543	1	HYDRAULIC MOTOR
52	68578	4	HHCS
53	68581	1	CE SPECIFICATION PLATE
56	370352	1	HHCS
57	371050	10	WASHER
58	371052	4	WASHER
59	371500	8	NYLOCK NUT
60	371501	2	NYLOCK NUT
61	371507	1	NYLOCK NUT
62	67708	1	HAMMER STOP
63	67705	1	TRAVELING LOCK
64	67704	1	HOUSING COVER
65	02504	2	CAPSCREW
66	00354	2	O-RING

# DH9000 PARTS ILLUSTRATION

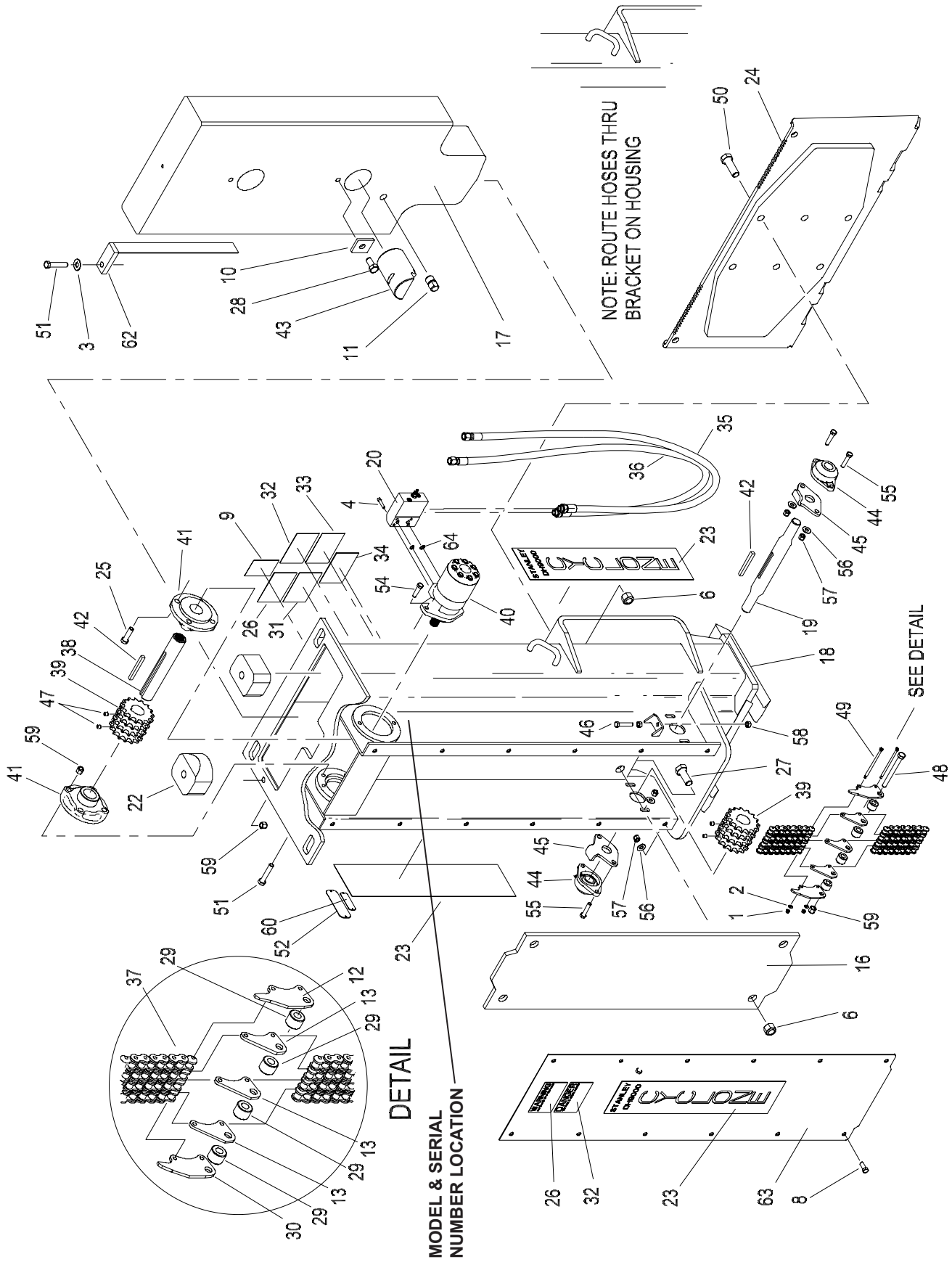

# DH9000 PARTS LIST

Item	SHT No.	Qty	Description
1	00719	2	NYLOCK NUT
2	04539	2	WASHER
3	04786	1	WASHER
4	06638	4	HSHCS
6	18600	10	NYLOCK NUT
8	20871	12	HHCS
9	47351	1	DECAL, COMPOSITE WARNING
10	67712	1	PEG LOCKING PLATE
11	67713	1	HAMMER SAFETY PIN
12	67714	1	RIGHT SIDE LIFT LUG
13	67716	3	CENTER LIFT LUG
16	67738	1	CHAIN WEAR SHEET
17	67764	1	HAMMER MACHINING
18	67771	1	HOUSING
19	67775	1	LOWER SHAFT
20	69790	1	MANIFOLD BLOCK
22	67779	2	POLY-BUSH
23	67780	3	DECAL, DH9000
24	67781	1	BRACKET WELDMENT
25	67790	4	HHCS
26	67791	2	DECAL, KEEP CLEAR OF HAMMER
27	67805	4	HHCS
28	67808	1	HHCS
29	67809	4	LIFT LUG SPACER
30	67853	1	LEFT SIDE LIFT LUG
31	67859	1	DECAL, TRAVEL LOCK
32	67860	2	DECAL, TOPPLING HAZARD
33	67861	1	DECAL, STABILITY HAZARD
34	67862	1	DECAL, EQUIP DAMAGE
35	67869	1	HOSE
36	67869	1	HOSE
37	67896	1	CHAIN
38	68213	1	DRIVE SHAFT
39	68277	2	SPROCKET
40	68280	1	HYDRAULIC MOTOR

Item	SHT No.	Qty	Description
41	68331	2	FLANGE BEARING PILOTED
42	68332	2	KEY
43	68366	1	HAMMER PEG
44	68503	2	FLANGE BEARING
45	68504	2	SHAFT ADJUSTER BRACKET
46	68506	2	HHCS
47	68519	4	SETSCREW
48	68520	1	HHCS
49	68521	2	SHOULDER SCREW
50	68578	6	HHCS
51	69654	5	HHCS
52	70982	1	CE SPEC PLATE
54	370252	2	HHCS
55	370253	4	HHCS
56	371050	16	WASHER
57	371500	16	NYLOCK NUT
58	371506	4	HEX NUT
59	67628	6	NYLOCK NUT
60	372037	1	SERIAL NUMBER PLATE
61	372155	2	DRIVE PIN
62	67773	1	TRAVELING LOCK
63	68206	1	HOUSING COVER
64	00354	2	O-RING



Stanley Hydraulic Tools  
3810 SE Naef Road  
Milwaukie, Oregon 97267  
503-659-5660 / Fax 503-652-1780  
[www.stanleyhydraulic.com](http://www.stanleyhydraulic.com)

**IMPORTANT**

To fill out a Product Warranty Recording form, and for information on your warranty, visit [Stanleyhydraulic.com](http://Stanleyhydraulic.com) and select the Warranty tab.  
**(NOTE:** The warranty recording form must be submitted to validate the warranty).