

---

Instructions for Use for

# Bio-Plex Pro™ & Bio-Plex Pro II Wash Stations

*Revision B*



Attention!

Use only the magnetic carrier which arrived with your instrument.

See page 17 for more details.





## Notice

Every effort has been made to avoid errors in text and diagrams; however, Bio-Rad Laboratories assumes no responsibility for any errors that may appear in this publication.

Bio-Rad reserves the right to change specifications at any time with appropriate validation, verification, and approvals.

## Copyright Information

The contents of this document are the property of Bio-Rad Laboratories and are not to be copied, reproduced, or transferred to another person or persons without written permission.

Copyright ©2008 Bio-Rad Laboratories

All rights reserved.

## Declaration of Conformity

See page 79.

## About the Instructions for Use (IFU)

This document describes the use of the Bio-Plex Wash Stations, designed for performing hands-free wash programs on Bio-Plex and other xMAP assays.

It contains instruction for the use of the instrument and is intended as a reference for the user. It contains information about the following:

- Installing the instrument
- Operating the instrument
- Programming of wash programs
- Definition of wash parameters
- Cleaning and maintenance procedures

## Trademarks

The following product names and any registered or unregistered trademarks mentioned in this document are used for identification purposes only and remain the exclusive property of their respective owners:

- Microcide is a registered trademark of Global Biotechnologies Inc., Portland, Maine, USA
- MagPlex and xMAP are trademarks of Luminex Corporation, Austin, TX, USA
- Tween is a registered trademark of ICI Americas, Inc., Wilmington, DE, USA
- Decon and Neutracon are registered trademarks of Decon Laboratories Limited, Sussex, UK
- HydroControl is a trademark of Tecan Group Ltd, Männedorf, Switzerland





# Table of Contents

TABLE OF CONTENTS.....	V
<b>BASIC OPERATION AND MAINTENANCE .....</b>	<b>11</b>
INSTRUMENT OPTIONS.....	11
MICROPLATE REQUIREMENTS .....	12
INSTALLING THE INSTRUMENT.....	13
<i>Bio-Plex Pro Installation Diagram.....</i>	<i>14</i>
<i>Bio-Plex Pro II Installation Diagram.....</i>	<i>15</i>
<i>Installing the Tubing Bracket (Bio-Plex Pro II only).....</i>	<i>16</i>
<i>Selecting and Installing a Plate Carrier.....</i>	<i>17</i>
<i>Changing the Vacuum Configuration .....</i>	<i>18</i>
INSTALLING THE MICROPLATE .....	19
TURNING ON THE POWER.....	19
KEYPAD BASICS .....	20
<i>Primary Menu .....</i>	<i>20</i>
<i>Secondary Menu .....</i>	<i>20</i>
PRIMING THE INSTRUMENT.....	20
<i>Failure to Prime .....</i>	<i>21</i>
PLATE WASHING PROGRAMS .....	22
WHICH WASH PROGRAM DO I USE?.....	23
<i>Quick Guide.....</i>	<i>23</i>
RINSING.....	24
RINSING.....	25
<i>Rinse Day.....</i>	<i>25</i>
<i>Rinse Night.....</i>	<i>26</i>
<i>Instrument state at the end of the wash .....</i>	<i>26</i>
CHANGING THE PLATE CARRIER.....	27
PREVENTIVE MAINTENANCE PLAN .....	28
<i>Daily.....</i>	<i>28</i>
<i>Weekly.....</i>	<i>28</i>
<i>Every Six Months.....</i>	<i>29</i>
<i>As Needed.....</i>	<i>29</i>
<i>Yearly (Service Engineer Required).....</i>	<i>29</i>

<b>REFERENCE SECTION .....</b>	<b>30</b>
PURPOSE OF REFERENCE SECTION .....	30
<b>INSTRUMENT DETAILS.....</b>	<b>31</b>
INSTRUMENT SAFETY.....	31
INTENDED USE .....	32
CONFIGURATIONS.....	33
INSTRUMENT SPECIFICATIONS .....	34
DESCRIPTION .....	36
BIO-PLEX PRO DIMENSIONS .....	37
BIO-PLEX PRO II DIMENSIONS.....	38
REAR PANEL CONNECTIONS .....	38
REAR PANEL CONNECTIONS .....	39
<b>DETAILED INSTALLATION .....</b>	<b>40</b>
REQUIRED WORKING AREA.....	40
POWER REQUIREMENTS .....	40
UNPACKING AND INSPECTION CHECKLISTS .....	40
<b>DETAILED OPERATING INSTRUCTIONS .....</b>	<b>42</b>
SWITCHING THE INSTRUMENT ON .....	42
COMPLETE INSTRUMENT KEYPAD FUNCTIONS.....	43
<i>Alphabetical list of LCD text with explanations.....</i>	<i>45</i>
DEFINING CUSTOM WASH PROGRAMS.....	48
WASH MODES .....	48
<i>Washing Positions.....</i>	<i>49</i>
ASPIRATING MODES .....	50
<i>Normal Aspiration Mode.....</i>	<i>50</i>
<i>Crosswise Aspiration Mode.....</i>	<i>50</i>
DRIP MODE.....	51
<b>DEFINING NEW PROGRAMS.....</b>	<b>53</b>
INTRODUCTION .....	53
PROGRAM MENU .....	53
DEFINE/EDIT A PROGRAM .....	54
<i>Process Step: Aspirate.....</i>	<i>55</i>
<i>Process Step: Dispense.....</i>	<i>56</i>
<i>Process Step: Wash.....</i>	<i>58</i>
<i>Process Step: Soak.....</i>	<i>59</i>
<i>Process Step: User Prompt.....</i>	<i>59</i>
<i>Process Step: Vacuum Filtration.....</i>	<i>59</i>
SHOW PROGRAM.....	60
CLEAR PROGRAM.....	61
SETTINGS MENU .....	61
<i>Edit Plates .....</i>	<i>62</i>
<i>Options Submenu.....</i>	<i>62</i>
<i>Vacuum Filtration.....</i>	<i>62</i>
<i>Bubble Sensor.....</i>	<i>63</i>
PROCEDURES MENU .....	63
<i>Rinse .....</i>	<i>63</i>
<i>Prime .....</i>	<i>63</i>
<i>Empty Prime Tray.....</i>	<i>63</i>
<b>MAINTENANCE AND CLEANING .....</b>	<b>65</b>
CLEANING PROCEDURES .....	65

<i>Cleaning the Cover and Display</i> .....	65
<i>Cleaning the Liquid System</i> .....	65
<i>Cleaning the Manifold</i> .....	66
<i>Cleaning Waste Bottles</i> .....	66
LIQUID OR FOAM SPILLS .....	67
REPLACING THE MANIFOLD .....	68
<i>Removing the Manifold</i> .....	69
<i>Installing the Manifold</i> .....	70
INSTRUMENT DISINFECTION .....	71
<i>Disinfection Solutions</i> .....	71
<i>Disinfection Procedure</i> .....	72
DISPOSAL OF INSTRUMENT .....	73
<i>Disposal of Operating Material</i> .....	73
<i>Disposal of the Instrument</i> .....	73
<b>TROUBLESHOOTING AND ERROR MESSAGES</b> .....	<b>75</b>
ERRORS WITHOUT MESSAGES.....	75
ERROR MESSAGES.....	75
<i>Plate Error</i> .....	75
<i>Program Too Big Error</i> .....	75
<i>Transport Error</i> .....	75
<i>Manifold Arm Error</i> .....	76
<i>Sensor Defect Error</i> .....	76
<i>RS485 Error</i> .....	76
<i>PC (Process Control) System Error</i> .....	77
<i>No Aspiration at Vacuum Filtration Error</i> .....	77
<i>LLD Errors</i> .....	78
<b>DECLARATION OF CONFORMITY</b> .....	<b>79</b>
<b>INDEX</b> .....	<b>80</b>

## Symbols

	Indicates the possible presence of biologically hazardous material.
	Indicates the possible presence of a strong magnetic field.

## Warnings, Cautions, and Notes

The following types of notices are used in this publication to highlight important information or to warn the user of a potentially dangerous situation:



**Information**  
Gives helpful information.



**Caution**

Indicates a possibility of instrument damage or data loss if instructions are not followed.



**WARNING**

Indicates the possibility of severe personal injury, loss of life, or equipment damage if the instructions are not followed.



**WARNING**

This symbol indicates the possible presence of biologically hazardous material. Proper laboratory safety precautions must be observed.



**Attention**

Negative environmental impacts associated with the treatment of waste.

- Do not treat electrical and electronic equipment as unsorted municipal waste
- Collect waste electrical and electronic equipment separately



**WARNING**

Risk of fire and explosion!



Ethanol is flammable and when improperly handled can lead to explosions. Proper laboratory safety precautions must be observed.



## Abbreviations

---

A	Ampere
°C	Degrees Celsius
CE	Conformité Européenne
cm	Centimeter
CV	Coefficient of Variation
ELISA	Enzyme-Linked ImmunoSorbent Assay
EN	European Norm: a voluntary European standard of the European Committee for Standardization or Comité Européen de Normalisation (CEN)
°F	Degrees Fahrenheit
IEC	International Electrotechnical Commission
IFU	Instructions for Use
in.	Inch
IVD	In Vitro Diagnostics
IVD-D	In Vitro Diagnostics Directive
kg	Kilogram
l; L	Liter
m	Meter
mBar	Millibar
ml	Milliliter
mm	Millimeter
mS	Millisiemens
µl	Microliter
PC	Process Control
PCR	Polymerase Chain Reaction
ppm	Parts Per Million
QC	Quality Control
REF	Reference Number/ Order Number
s	Second
SN	Serial Number
T	Träge (Slow Blow Fuse)
torr	Torr – Millimeter of Mercury (mmHg)
TYPE	Name and Type of instrument
USB	Universal Serial Bus
V	Volt
VA	Volt Ampere
WEEE	Waste Electrical and Electronic Equipment



# Basic Operation and Maintenance

This section gives you instructions to configure, install, prime, and use the Bio-Plex Pro™ and Bio-Plex Pro II Wash Stations. You can perform your first plate wash simply by using these instructions and the onboard wash program. This section also contains references to more detailed information throughout this manual.

## *Instrument Options*

The Bio-Plex Pro and Bio-Plex Pro II Wash Stations are designed for strip-wise washing of 96-well microplates. They are designed primarily for the processing of Bio-Plex and other xMAP assays.

The wash station is available in two versions.

Wash Configuration	Bio-Plex Pro	Bio-Plex Pro II
Vacuum filtration	No	Yes
Magnetic separation	Yes	Yes

Both wash stations are delivered with the standard carrier installed and the appropriate programs for performing your assays. Replace the standard carrier with the appropriate carrier for your assays as outlined on page 17.

Which Wash Program Do I Use? On page 23 describes the standard wash programs necessary for the different assays.

To run standard ELISAs or other plate-based assays, you must modify programs and plate definitions, using the HydroControl™ software available on the CD that ships with both instruments. This software is not needed for Bio-Plex or Bio-Plex Pro assay processing. Follow the instructions in Defining New Programs on page 53.

## Microplate Requirements



**Use recommended microplates. If you use different microplates, your assay results may not be reproducible, and you may experience excessive bead loss.**

### Recommended microplates for magnetic assays:

Bio-Rad Part #	Description	Default for Magnetic Products
171-025001	<b>Bio-Plex Pro flat-bottom plates</b>	Yes

\*For a complete list of suitable plates, please contact Bio-Rad technical support.

Only these recommended filter plates should be used with the Bio-Plex Pro II, when configured for standard Bio-Plex or other polystyrene bead based xMAP assays.

### Recommended microplates for vacuum filtration:

Vendor	Manufacturer Part #	Default for Vacuum Products
Millipore	MSBVS1210	Yes

If using other microplates, you will have to enter new microplate definitions, using the Hydrocontrol software included on the CD. Please note the following requirements.

Parameters	Characteristics
Max. overall microplate height	14.35 mm ± 0.76 mm (0.5650 inches ± 0.0299 inches)
Footprint	9.0 mm (0.3543 inches)
Pitch size (center to center)	9.0 mm (0.3543 inches)
Bottom shape	Round, V-shaped, and flat

## Installing the Instrument

Unpack the instrument and install the instrument according to the instructions below.

Additional helpful information is located on the following pages:

- Unpacking checklist on page 40
- Bio-Plex Pro installation diagram on page 14
- Bio-Plex Pro II installation diagram on page 15



### Caution

**Do NOT turn the instrument on until you have completed the steps below.**



### Caution

**Before the instrument is installed and switched on, it should be left to stand for at least three hours, so there is no possibility of condensation causing a short circuit.**

1. Ensure that the on/off switch in the rear panel of the instrument is in the off position.
2. Connect the solution tubes (L1 and L2) to the inlet connectors on the rear panel of the instrument. See the diagrams on the following pages.
3. Connect the solution tubes to the corresponding liquid bottles.
4. Connect the waste tube to the waste bottle (do not kink the tubes).
5. IF your instrument is a Bio-Plex Pro II, install the tubing bracket as shown on page 16.
6. Fill Liquid 1 bottle with Bio-Plex wash buffer.
7. Fill Liquid 2 bottle with distilled or higher grade water.
8. Remove the standard ELISA carrier and install the appropriate plate carrier based on the assays you will be running (Selecting and Installing a Plate Carrier on page 17).

## Bio-Plex Pro Installation Diagram

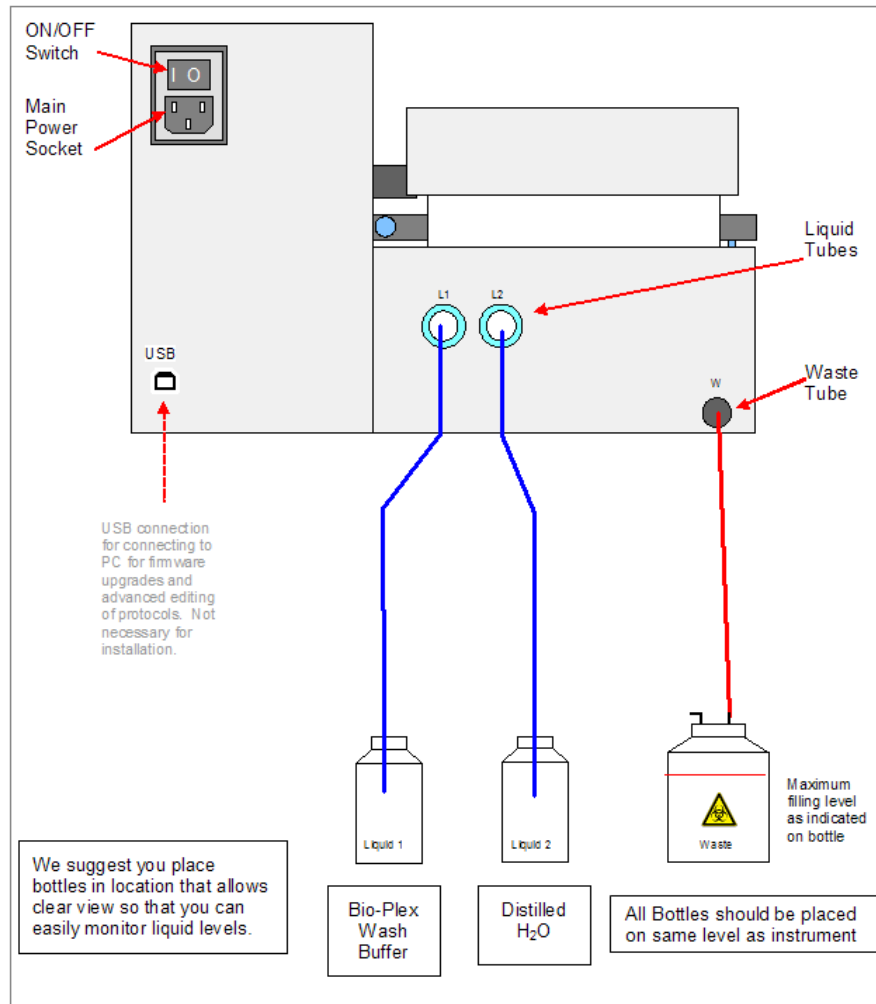

## Bio-Plex Pro II Installation Diagram

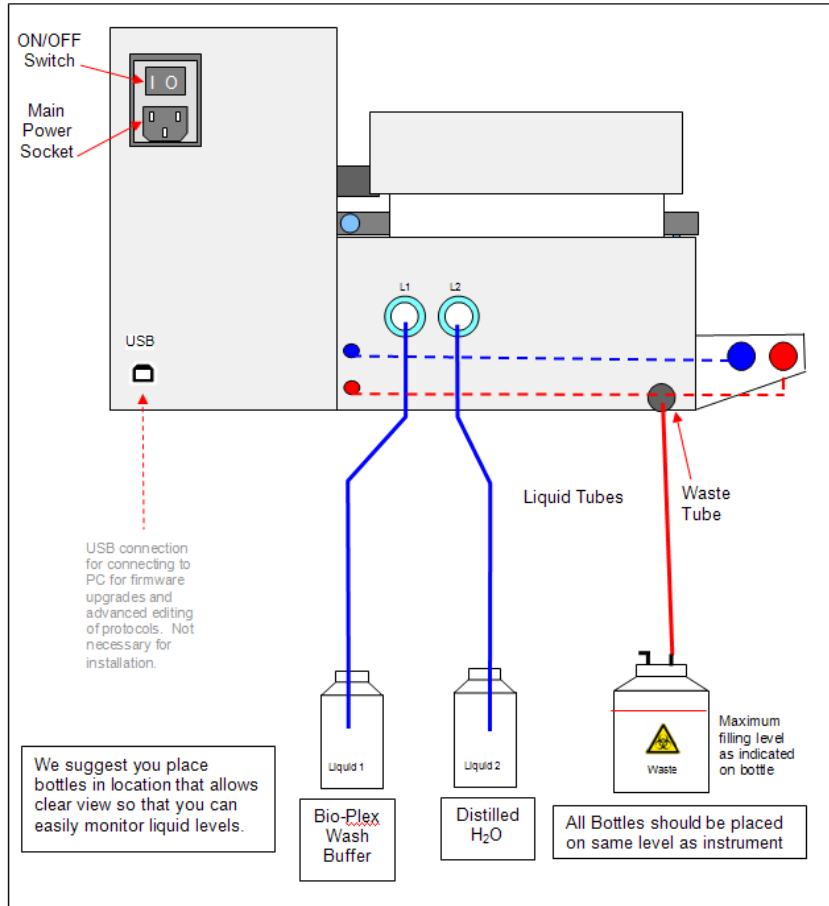

## ***Installing the Tubing Bracket (Bio-Plex Pro II only)***

Your Bio-Plex Pro II is shipped with the liquid hoses attached. Attach the tubing bracket to the left side of the instrument, as shown in the pictures below.

### ***Location of Tubing Bracket***

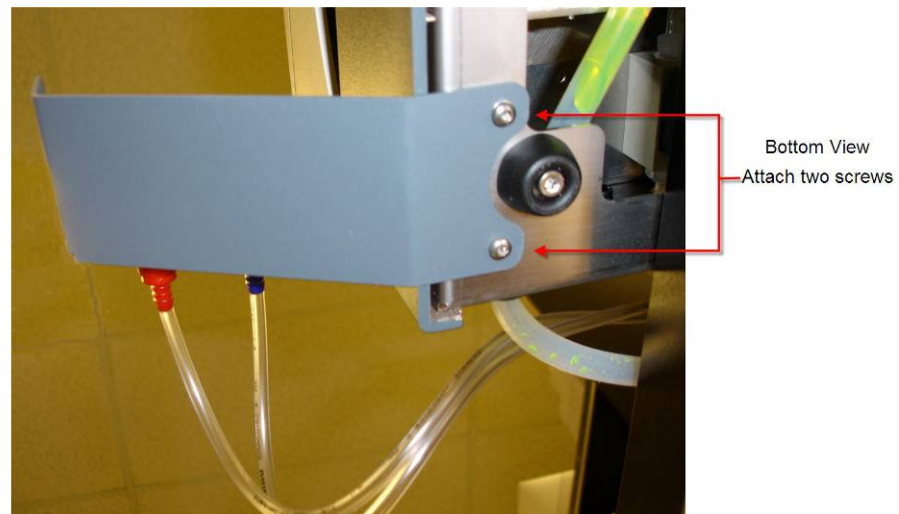
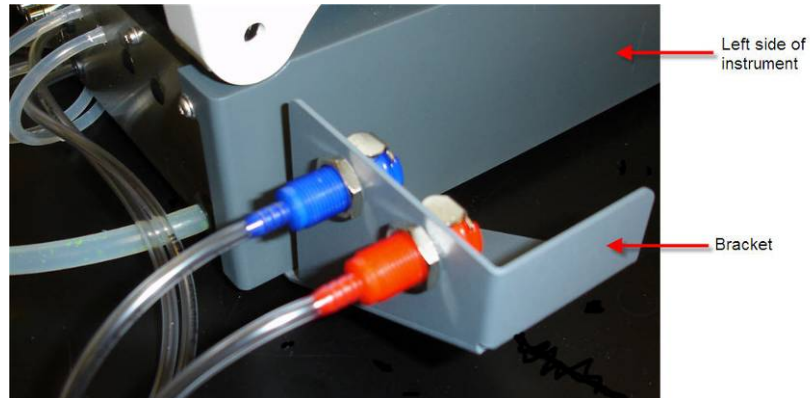

A tool is provided for the installation of the bracket. It is located in a bag containing a USB cable and cleaning pins for the manifold.



## Selecting and Installing a Plate Carrier



### Attention!

Use only the type of magnetic carrier which arrived with your instrument.

If your wash station arrived with version B use of version A on your wash station will result in poor assays results.

Version B is back-compatible with previously installed wash stations.

### Magnetic Plate Carrier

(Version B)

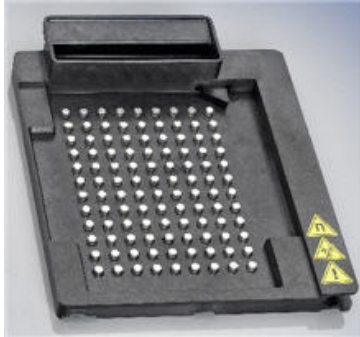

(Version A)



### Vacuum Plate Carrier



Use magnetic plate carrier with:

- Bio-Plex Pro assays
- Bio-Plex Precision Pro™ assays
- Any assay with MagPlex™ microspheres

Use vacuum plate carrier with:

- Bio-Plex assays (non magnetic)
- Any assay on Bio-Plex COOH beads
- Any assay on MicroPlex microspheres

### Remove the standard ELISA plate.

1. Make sure the instrument is turned off.
2. Lift the manifold arm.
3. Slightly tilt the plate carrier towards the right.



4. Carefully slide the plate carrier toward the front of the instrument until it clears the guide bar.

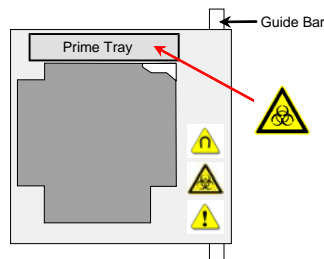

**Installing the plate carrier** is the reverse of the procedure above:

1. Carefully guide the plate carrier onto the guide bar in a slightly tilted position, as shown above.
2. Push the plate carrier completely into the instrument, so that the front of the carrier is even with or past the Bio-Rad logo.
3. Lower the plate carrier.
4. Lower the manifold arm.

## Changing the Vacuum Configuration

You must set the vacuum system appropriately for the plate carrier used. This is done through the VACUUM FILTR menu. Follow the procedure shown below to:

- Enable Low VAC when using the vacuum carrier
- Disable Low VAC when
  - 1). using the magnetic carrier
  - 2). using the standard ELISA plate carrier

### Disabling/Enabling the Vacuum Carrier

Go through these menus to disable or enable the vacuum carrier. If you are disabling the vacuum, the menus will display “Disable” in place of “Enable.”

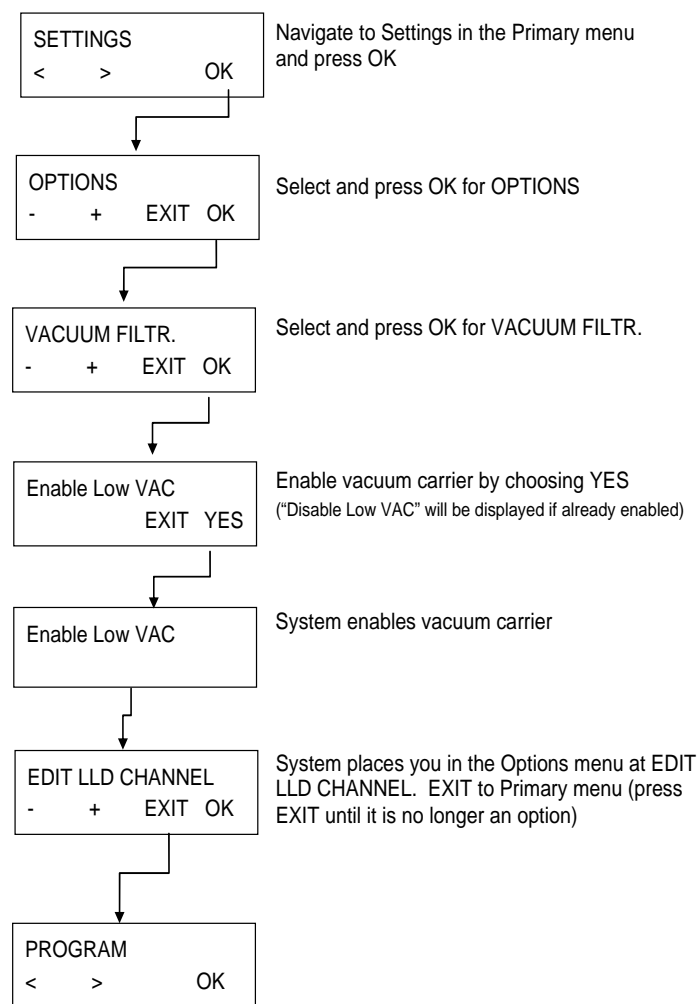

Failure to set Vacuum Filtration settings appropriately for the installed plate carrier will result in a MANIFOLD HEAD UP error. This indicates that the manifold arm cannot lower appropriately.

**The instrument must be turned off and then back on for the change to take effect.**

## Installing the Microplate

Insert the 96-well microplate into the plate transport for washing and ensure that the microplate is correctly oriented (position A1 of the plate corresponds to position A1 marked on the plate transport). If using the vacuum plate carrier for polystyrene-based assays, see Changing the Plate Carrier on page 23.

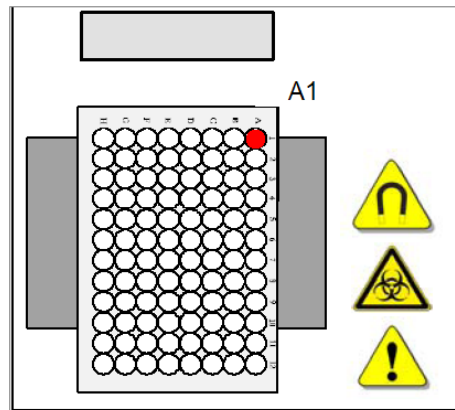

## Turning on the Power

The power switch is located at the rear of the instrument, above the power cable connection. Make sure the instrument is plugged in using the provided power cable before you attempt to operate.

## Keypad Basics

All the functions you need to run Bio-Plex programs are easily accessed using the keypad on your wash station. The system is organized into primary and secondary menus.

### Primary Menu

The instrument menu has the following options:

Primary Menu Options	Functions	Secondary Menu Options
Programs	Wash programs used to process assays	Start, Define/Edit, Show, Clear
Settings	Rarely accessed advanced features	Edit Plates, Options, Bubble Sensor
Procedures	Preparation or maintenance processes	Prime, Rinse, Empty Prime Tray, Vacuum Filtration

### Secondary Menu

If you choose OK when any of the primary menu options (Programs, Settings, and Procedures) are visible on the LED, you will navigate to the secondary menus. You may select a choice from the secondary menu, or press Exit to return to the primary menu.

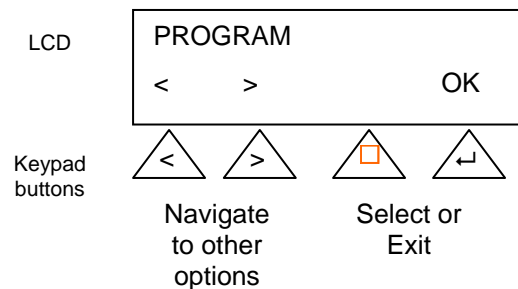

If you get confused about where you are, press Exit, until you no longer see Exit as an option.

## Priming the Instrument

You should prime both Channel 1 and 2 after installation and if the instrument has not been used for an extended period of time. Priming is performed to fill the liquid system of the instrument and to remove all air from the tubes. A priming step must also be performed when switching to a different wash buffer.



**Caution**  
Do not use your new instrument until you have primed both channels.

Perform priming for both channels using the following procedure:

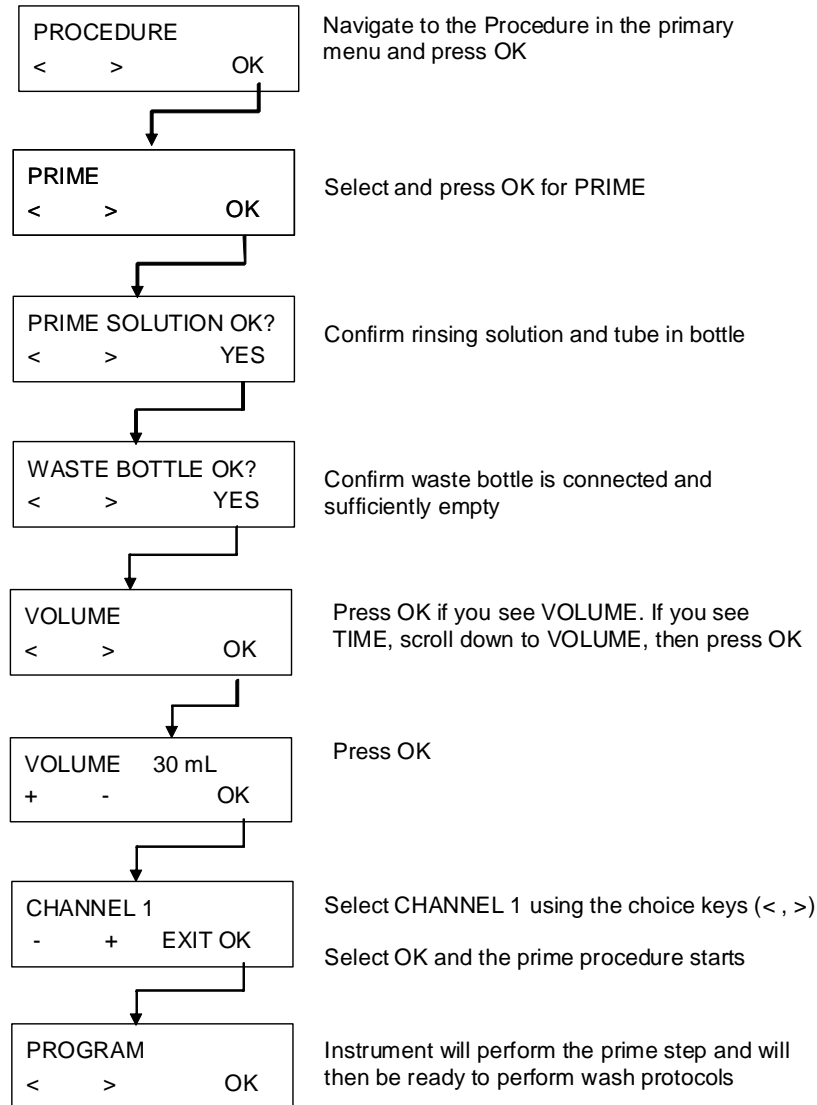

Repeat for channel 2.

## Failure to Prime

If you have a new instrument or it has not been used for a long time the pump may fail to draw fluid from the liquid bottles. This problem is easily solved.

1. Disconnect the L1 tube from the bottle (leaving it connected to the instrument).
2. Hold the free end of the tube high and pipette 3 - 4 ml of deionized water to the tube while performing the prime procedure in channel 1 as described above.

Alternately you may carefully use a syringe to inject 1 - 2 ml of water directly into the L1 port of the instrument, reconnect the tubing, and run a prime procedure.

## Plate Washing Programs

Instructions for running the preconfigured wash program are detailed below. Instructions for setting new Wash, Dispense, and Aspirate modes into a new wash program, and instrument rinse instructions, are found in the Defining New Programs section on page 53.

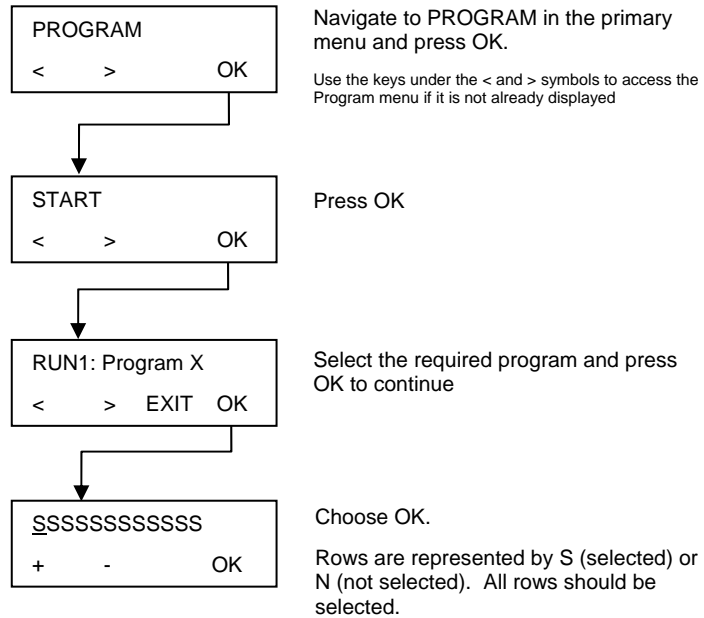

**It is highly recommended that all wells are selected and the entire plate is washed.**

## Which Wash Program Do I Use?

In this instance.	Use Wash Station Program
First wash, magnetic assay	MAG x2
All other washes, magnetic assay	MAG x3
Prewash, vacuum assay	PREVAC
First wash, vacuum assay	VAC x2
All other washes, vacuum assay	VAC x3
Third party kits which require 200 µl washes (Vacuum only)	V 200 x2 or V 200 x3

For all protocols, it is highly recommended that you wash the entire plate. See page 18 for details.

## Quick Guide

Manual Steps	Wash Station Protocols
<p><b><u>Vacuum Program Only</u></b>            Dispense 125uL Assay Buffer            Perform Prewet Program</p>	PREVAC
<p>Dispense 50uL Bead suspension            Wash 2 cycles</p>	MAG x2 or VAC x2
<p>Dispense 50uL standards and solutions            *Incubate for 30-120 minutes. (Refer to assay manual)            Wash 3 cycles</p>	MAG x3 or VAC x3
<p>Dispense 25uL detection antibody            *Incubate for 30 minute            Wash 3 cycles</p>	
<p>Dispense 50uL SA-PE            *Incubate for 10 minutes            Wash 3 cycles</p>	
<p>Dispense 125uL Assay Buffer            Place on shaker and shake for 1 minute            Read on Bio-Plex Reader</p>	

\*Incubating reaction plates should be

- At room temperature
- Covered with aluminum foil, or otherwise protected from light
- Shaken at 900-1100 rpm for the first 30 seconds, and at 300 rpm for the remainder of the incubation

## Important Vacuum Protocol Precautions

- Carefully place the plate so that it is flat and squarely seated between the metal frames on the vacuum carrier before stating a vacuum protocol
- It may be necessary to apply a small amount of pressure to the plate for the first vacuum cycle of the day
- Monitor your plate periodically to ensure complete removal of wash buffer before the next dispense cycle
- Blot the bottom of the filter plate on a paper towel within 5 seconds after each program is completed. If you are not sure how much time has elapsed, run a PREVAC program to clear any residual buffer that may have wicked back into the wells before proceeding to the next step

## Vacuum protocols will not work if you do not have buffer in every well.

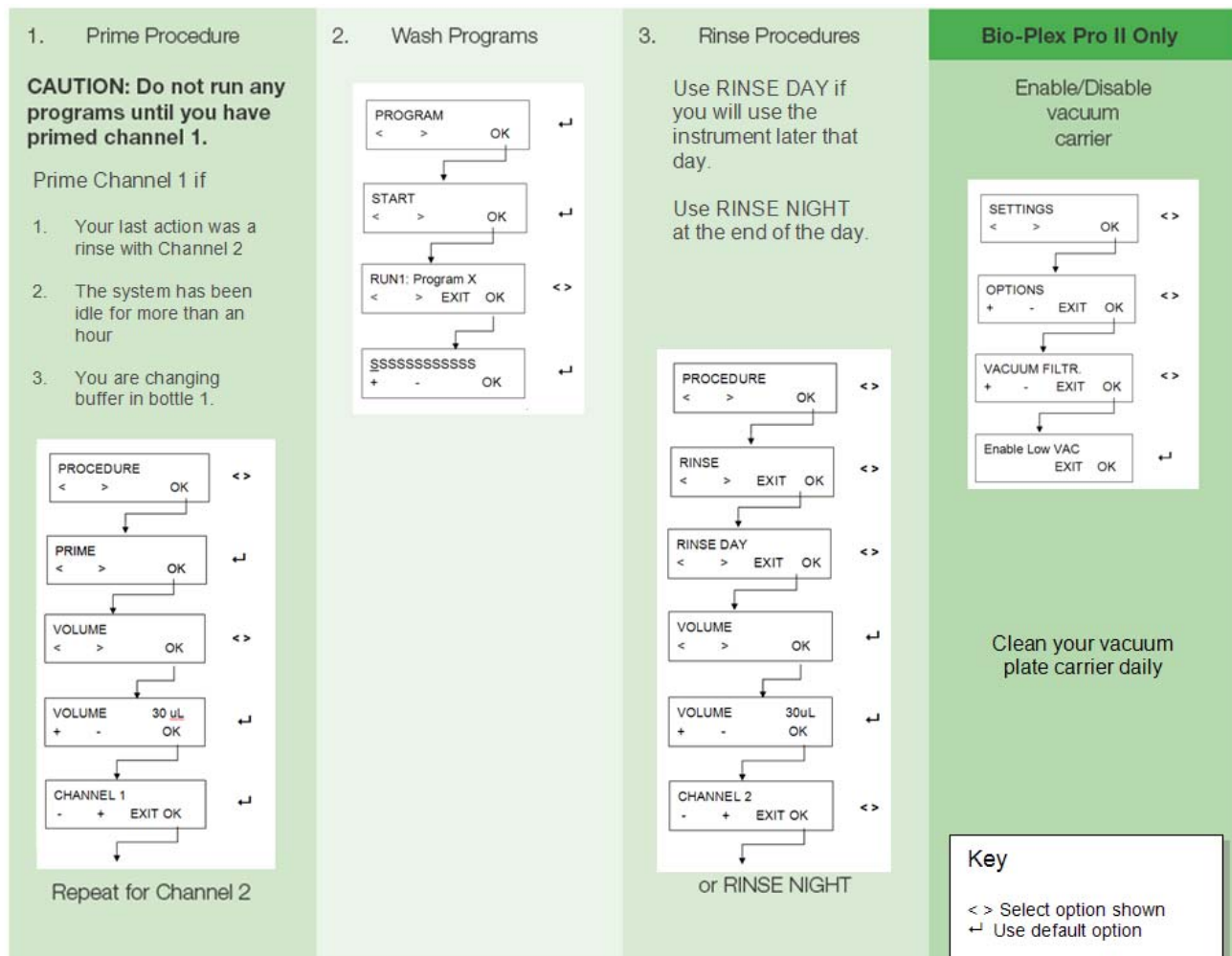



## Rinsing

The instrument should always be rinsed after use. Afterwards, the instrument can either be left switched on, with the manifold in the rinsing solution, or switched off after performing the correct maintenance.

## Rinse Day

If the instrument will be left to stand for a short time (i.e. up to 2 hours), you may perform Rinse Day with wash buffer so that you do not have to prime before the next run.

Perform Rinse Day by making these menu choices:

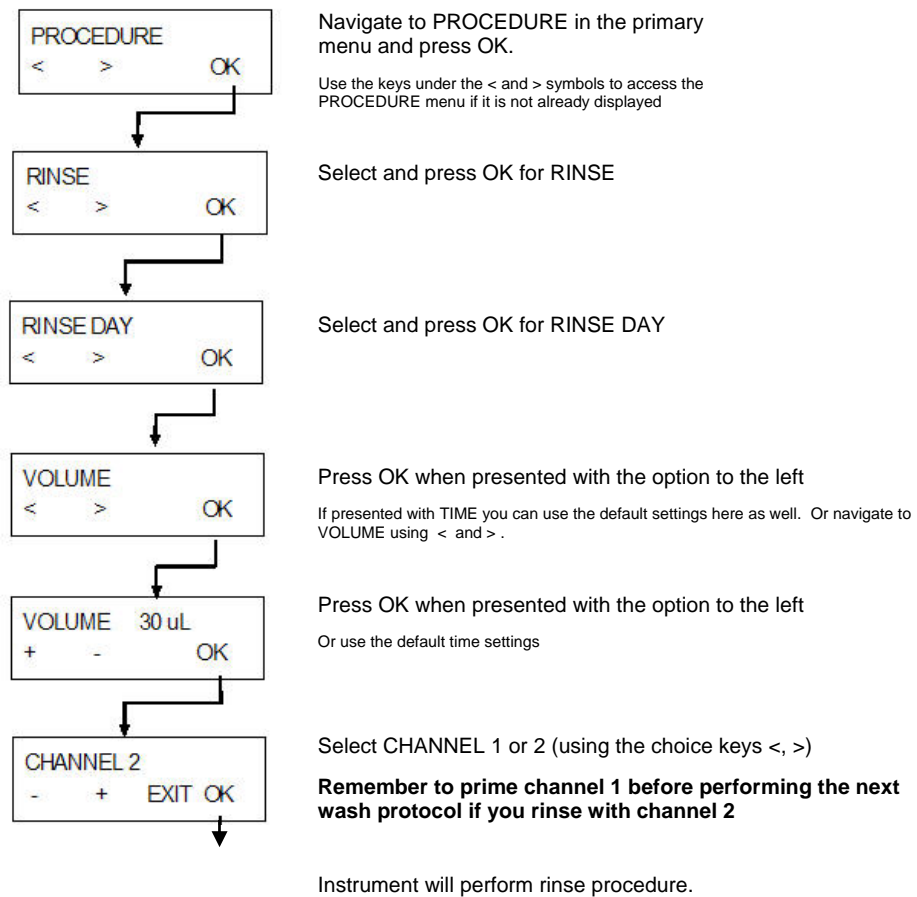

When the rinsing procedure is complete, the following message is displayed:

```

RINSE DAY
STOP END
    
```

The manifold remains in the prime tray until END is pressed.  
 Press STOP to abort the procedure (prime tray will not be aspirated).

## Rinse Night

If the instrument will be left to stand for a longer period of time (such as overnight), perform the Rinse Night procedure using these menu choices:

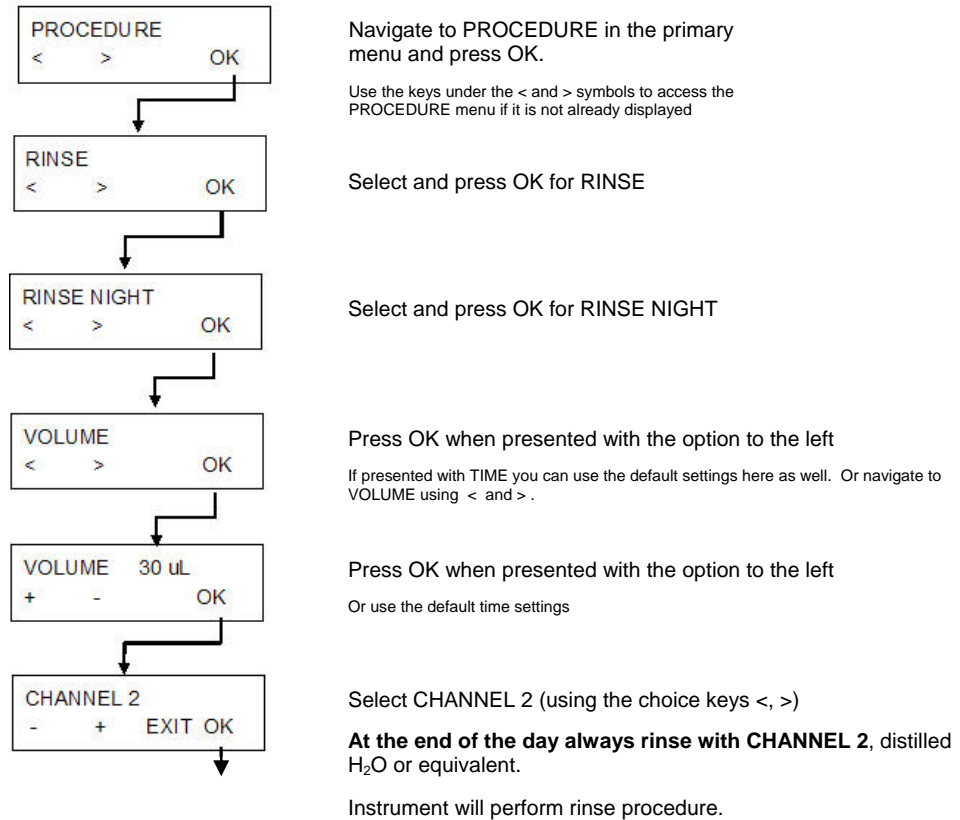

When the rinsing procedure is completed the following message is displayed:

RINSE NIGHT  
STOP END

The manifold remains in the prime tray until END is pressed. Press STOP to abort the procedure (prime tray will not be aspirated).

## Instrument state at the end of the wash

Considerations for leaving the instrument on or off after a rinse procedure.

- Leave the instrument on if you want to soak the manifold overnight (Recommended during periods of heavy use)
- Shut the instrument off if you do not wish to soak the manifold (**Rinse Night only**)

If the instrument will be switched off at the end of operation, the Rinse Night procedure should be performed. This prevents the needles from becoming blocked.

Use the Rinse Night procedure to rinse the wash system as outlined above.

When the rinsing procedure is completed the following message is displayed:

RINSE NIGHT  
STOP END

The manifold remains in the prime tray until END is pressed. Press STOP to abort the procedure (prime tray will not be aspirated).



**The most important cleaning procedure for this instrument is rinsing the liquid system with distilled water at the end of each day.**

## ***Changing the Plate Carrier***

See Page 16 for detailed instructions on selecting and replacing the plate carrier.

## Preventive Maintenance Plan



### WARNING

All parts of the instrument that come into contact with potentially infectious material must be treated as potentially infectious areas.

It is advisable to adhere to applicable safety precautions, (including the wearing of powder-free gloves, safety glasses and protective clothing) to avoid potential infectious disease contamination when performing cleaning procedures and also when making adjustments to the instrument.



### WARNING

#### RISK OF FIRE AND EXPLOSION!

Prior to cleaning the outer surface of the instrument and the display, switch off the instrument and disconnect it from the main power supply!

### Daily

- Prime the liquid system if necessary
- Perform Rinse Day with wash buffer, if the instrument is left to stand for a short time (up to 2 hours). Use distilled water if you anticipate longer intervals between uses
- Perform Rinse Night with distilled water at the end of a day of use
- If necessary (due to particles, soiling, etc.), prime the instrument several times with distilled water
- If the instrument will be left to stand for a longer period of time (more than one week), prime with distilled water and then prime without liquid

### Weekly

- Perform Rinse Night with distilled water and soak the manifold overnight (leave instrument on)
- Prime the instrument without liquid to empty the entire liquid system. (Reconnect the lines and prime with distilled water unless not using the instrument for an extended period)
- Check the filter(s) in the liquid bottle(s) for particles and rinse liquid filter(s) with distilled water
- Clean the plate carrier guide bar with 70% ethanol

## ***Every Six Months***

- Clean the plate carrier guide bar with 70% ethanol
- Remove the magnetic plate carrier and check the spring-loaded centering mechanism at the right rear of the carrier. If the mechanism does not move freely, rinse thoroughly with 70% ethanol
- Clean aspiration and dispensing needles. Two kinds of cleaning needles are supplied with the instrument. Clean the manifold aspirating needles with the smaller of the two. Clean the dispensing needles with the thicker cleaning needles. Carefully raise the manifold arm and clean each instrument needle by inserting the cleaning needle into the instrument needle and gently agitating, to remove any possible debris. Then rinse with water
- If you choose to remove the manifold for cleaning refer to page 66 for instructions

## ***As Needed***

To replace the plate carrier seal:

1. If the plate carrier seal becomes visibly damaged, remove the defective seal and clean the plate carrier frame with ethanol, making sure no adhesive is left
2. Peel back the protective paper from the new seal and attach to the plate carrier frame be careful not to block the ventilation hole



**Note**

***Clean the aspirating and dispensing needles periodically or immediately if they become clogged with particles or crystals.***

## ***Yearly (Service Engineer Required)***

Yearly maintenance is performed by the service engineer.

# Reference Section

## *Purpose of reference section*

Use this section if you have questions that are not answered in Basic Operation and Maintenance.

The reference section is provided for customers interested in more detail about the operation of the wash stations. Provided you follow standard safety precautions this section is not required for normal operation.

There is some information in this section for troubleshooting and advanced programming options.

# Instrument Details

## Instrument Safety

Always follow basic safety precautions when using this product to reduce the risk of injury, fire, or electrical shock.

Read and understand all information in the IFU. Failure to read, understand, and follow the instructions may result in damage to the product, injury to operating personnel, or poor instrument performance.

Observe all Warning and Caution notices (see Warnings, Cautions, and Notes on page viii for a description of the notices used in this document).

Never open the Instrument while the instrument is plugged into a power source.

Observe proper laboratory safety precautions, such as wearing protective clothing and using approved laboratory safety procedures.



### Note

#### *Suitable Compact Microplates*

*The instrument supports the processing of flat, round, or v-shaped bottom microplates in 96-well format typically used for Enzyme Immunoassays (EIA), which conform to the standard defined by the Society of Biomolecular Screening. However it is recommended that you only use the recommended plates for xMAP assays.*



### WARNING

#### Waste bottle – Liquid level

Make sure the liquid level of the waste bottle is always kept below the maximum level indicated on the bottle, to avoid overflow. As the contents of the waste bottle are potentially infectious, wear protective clothing (gloves, lab coat, and safety glasses) when emptying / handling a waste bottle.

Inquire about appropriate collecting points and approved methods of disposal in your country, state, or region.

**WARNING**

When using wash buffers that show a strong tendency to foam, empty the waste bottle as soon as the foam level has reached the maximum filling level indicated on the waste bottle. Add a commercially available anti-foaming agent (such as silicone oil) to the empty waste bottle to reduce foaming.



If foaming continues to be a problem, we recommend switching to a larger waste bottle (not provided with the Instrument) and to increase the concentration of anti-foaming agent in the waste bottle. To help facilitate breakdown of the foam in the waste bottle, carefully swirl the waste bottle from time to time to improve mixing between foam layer and anti-foaming agent.

Refill anti-foaming agent after emptying waste bottle. For example, when using the Wacker Anti-Foam Emulsion SE47 (Wacker article code 21640582), the recommended concentration is 1 ml of antifoaming agent for 1 liter of waste solution.

Use antifoaming agents and concentrations as recommended by corresponding manufacturers.

## ***Intended Use***

The Bio-Plex Pro and Bio-Plex Pro II are instruments for strip-wise processing of microplates in the 96-well format. The instrument is designed for professional use only and should only be operated by trained personnel.

**Caution**



The wash results obtained with the Instrument are influenced by the correct use of the instrument, according to the instructions given in this document, as well as the liquid compounds used (reagents, wash buffer, chemical components). The instructions for use, storage, and other handling in connection with samples or reagents must be strictly followed.

**Caution**



Before the instrument is installed and switched on, it should be left to stand for at least three hours, so there is no possibility of condensation causing a short circuit.

**Caution**



Before washing procedures are started, make sure that the microplate position A1 is inserted correctly.



The instrument is a general purpose laboratory instrument (Europe) and is a Class I General Controls medical device (U.S.) for the processing of samples from biological and non-biological origin.

The wash stations are designed primarily for the processing of Bio-Plex and other xMAP assays. The instruments may also be used for the processing of ELISA assays and the washing of adherent cells.

## Configurations

Both wash stations are delivered with the magnetic carrier installed and the appropriate programs for performing the wash steps of magnetic bead based assays. The Bio-Plex Pro II is also supplied with a vacuum manifold plate carrier to perform wash steps for standard Bio-Plex assays and other non magnetic xMAP assays. In order to do this, you must install the vacuum manifold plate carrier and connect the appropriate tubing as indicated in Changing the Plate Carrier on page 23. You must also redefine the configuration of the instrument using the keypad as outlined in Complete Instrument Keypad Functions on page 43. Use the appropriate standard programs.

Both instruments can also be used to process other plate-based assays. If you wish to do so, you can leave the magnetic carrier in place. If you have concerns about the magnetic fields affecting your assay, you can replace the magnetic plate carrier with the standard plate carrier. Make sure you reconfigure the system as outlined in Complete Instrument Keypad Functions on page 43.



### Caution

**Unauthorized modification of the instrument, any of its options and/or components as well as on any corresponding software or spare parts will result in a loss of warranty and a potential loss in instrument performance.**



### Caution

**It is important to understand that the proper installation of the instrument and software alone will not ensure compliance with national, regional, or local regulations. A range of policies and standard operating procedures according to applicable regulations must additionally be established.**



### Caution

#### **Mandatory System Validation by Operating Authority**

**The instrument has been validated on representative Enzyme Immunoassays (EIA) only in Europe. It is therefore the responsibility of any Operating Authority to ensure that the instrument has been validated according to applicable regulations for each specific assay used on the instrument.**

## Instrument Specifications



**Note**

**Instrument specifications have been defined using Bio-Plex Pro flat bottom microplates (Cat # 171025001), and may vary using other 96-well plates.**

The table below lists the specifications for the instrument. All specifications listed below are based on the following instrument settings:

Dispense/Wash rate: 250 µl/s/well

Aspiration rate: 3

PARAMETERS	CHARACTERISTICS
<b>General</b>	
Display unit	Liquid Crystal Display with 2 rows of 16 digits
Keyboard	4-key membrane keyboard
Number of dispensing channels	Up to 4 channels
Manifold types	8 channel manifold
USB Interface	All connected devices must be approved and listed as per IEC 60950-1 Information Technology Equipment – Safety or equivalent local standards.
<b>Variable</b>	
Volume of solution dispensed	50 - 3000 µl in 50 µl increments for washing 50 - 400 µl in 50 µl increments for dispensing
Dispensing accuracy	<= 2 %  Measured under following conditions:  8-way manifold, 300 µl, dispensing rate 3 (250 µl/s/well), wash buffer, Bio-Rad 96-well flat-bottom plates (Cat. # 171025001).
Dispensing uniformity	<= 4 % CV  Measured under following conditions:  8-way manifold, 300 µl, dispensing rate 3 (250 µl/s/well), wash buffer, Bio-Rad 96-well flat bottom plates (Cat. # 171025001).
Residual volume	Measured under following conditions:  <= 4 µl / well, using Bio-Plex Pro flat-bottom plates and the recommended preloaded programs. (Optimized for high bead recovery and low assay %CVs.)

PARAMETERS	CHARACTERISTICS
Carry over between wells	<= 1 ppm The carry over between wells <= 1 ppm cannot be guaranteed if not all wells are filled with liquid.
<b>Vacuum Filtration</b>	
Vacuum range (Bio-Plex Pro II Only)	-50 to -150 mBar absolute pressure
<b>Power</b>	
Supply	Auto-sensing 100 - 120 V or 220 - 240 V, 50/60 Hz
Consumption	< 65 VA
<b>Physical</b>	
Outside dimensions (without Vacuum Filtration)	Width: 275 mm, Depth: 366 mm, Height: 180.5 mm (Width: 10.8 in., Depth: 14.4 in., Height: 7.1 in.) <i>Greater depth and height in service position</i>
Weight (without Vacuum Filtration)	6.6 kg
<b>Environmental</b>	
Ambient temperature	
Operation	15°C to 35°C (59°F to 95°F)
Storage	-20°C to 60°C (-4°F to 140°F)
Relative Humidity	
Operation	20 % to 80 % non-condensing
Storage	10 % to 80 % non-condensing
<b>Others</b>	
Overvoltage category	II
Pollution degree	2
Method of disposal	Electronic waste (infectious waste)

## Description

The diagram below shows the main components of the instrument:

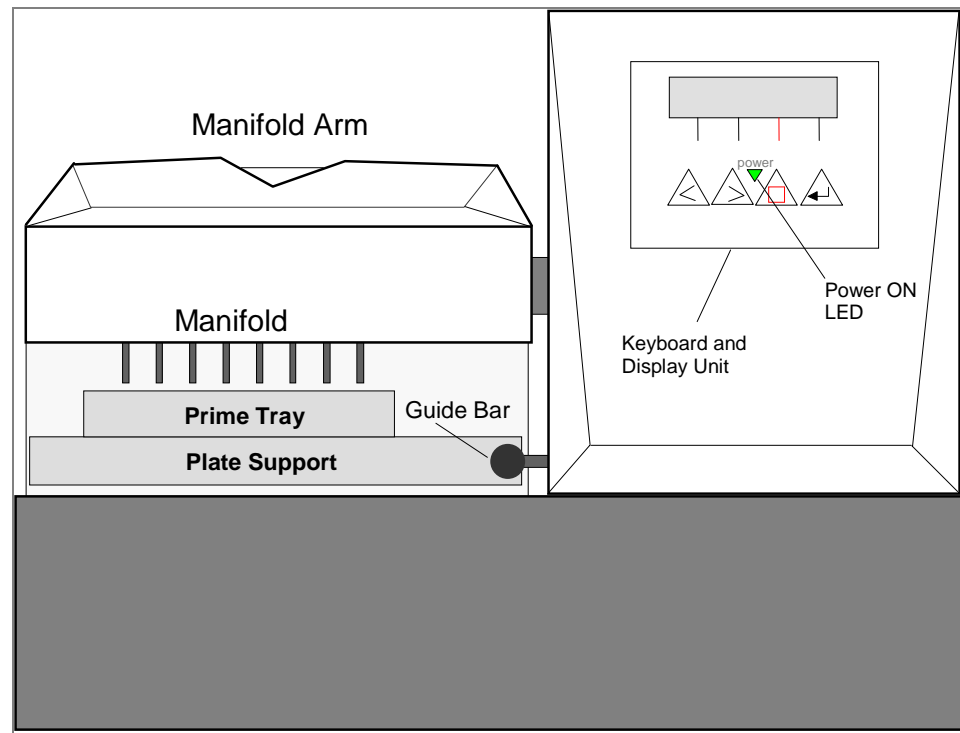

## Liquid System Diagram

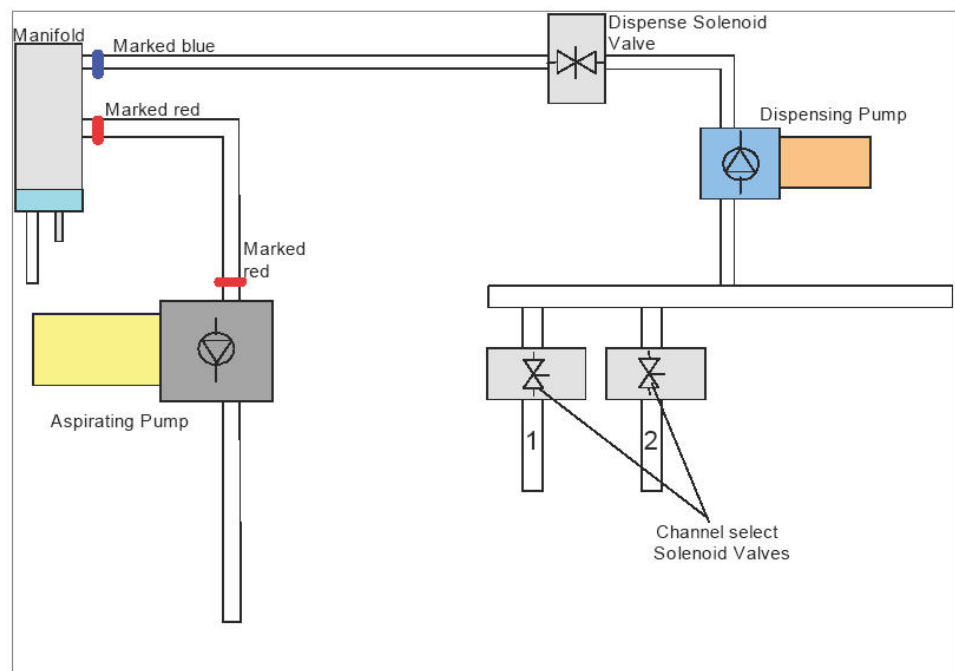

## Bio-Plex Pro Dimensions

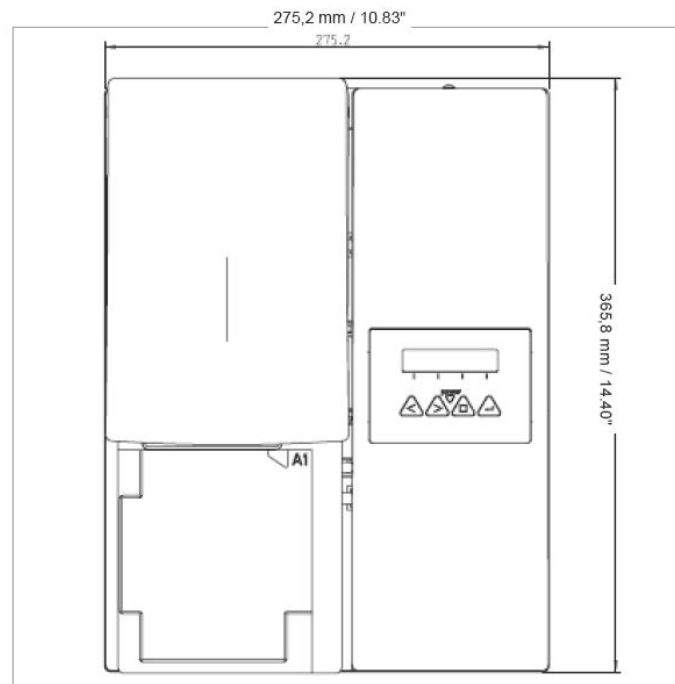
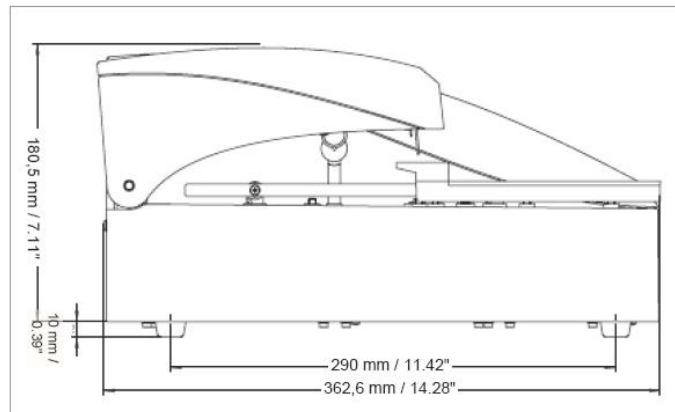
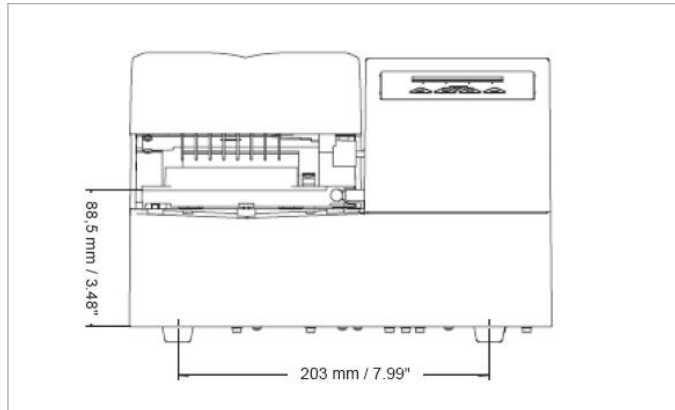

# Bio-Plex Pro II Dimensions

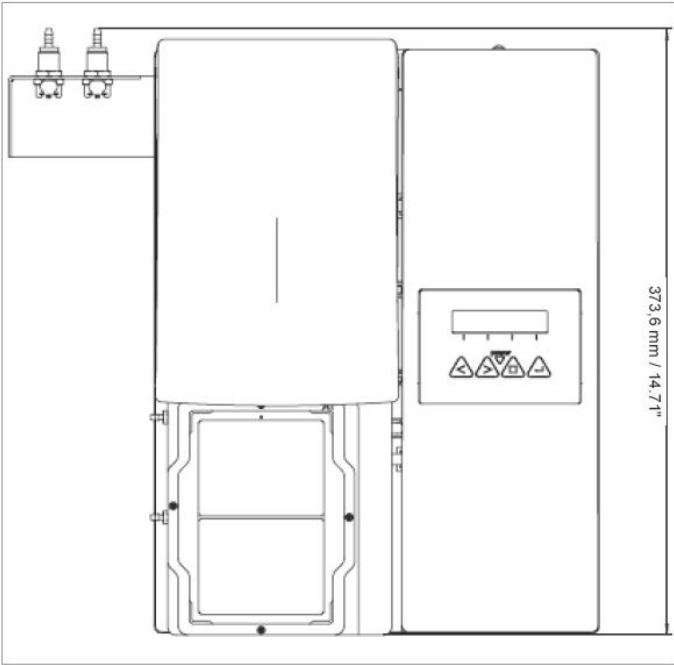
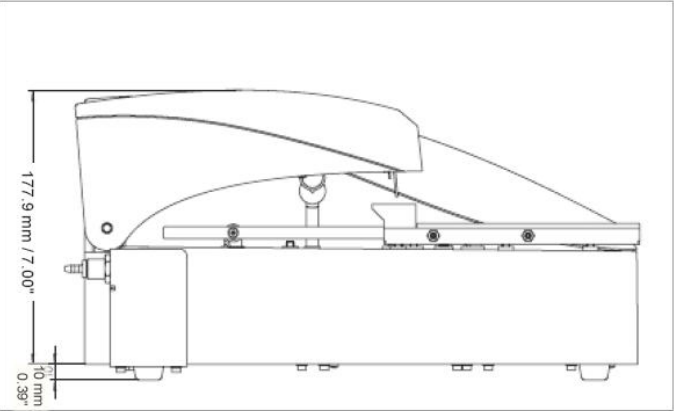
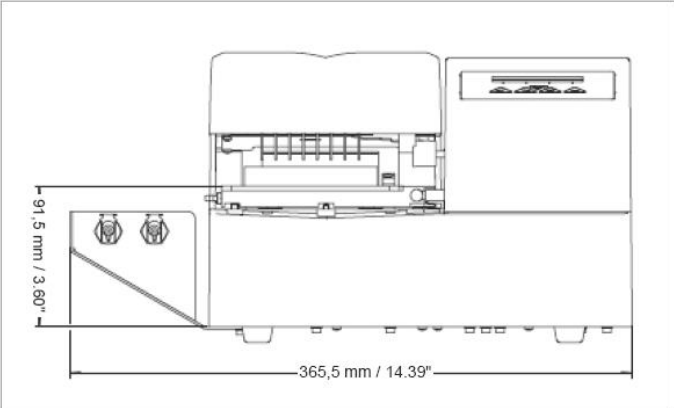

## Rear Panel Connections

The instrument has the following connections on the rear panel:

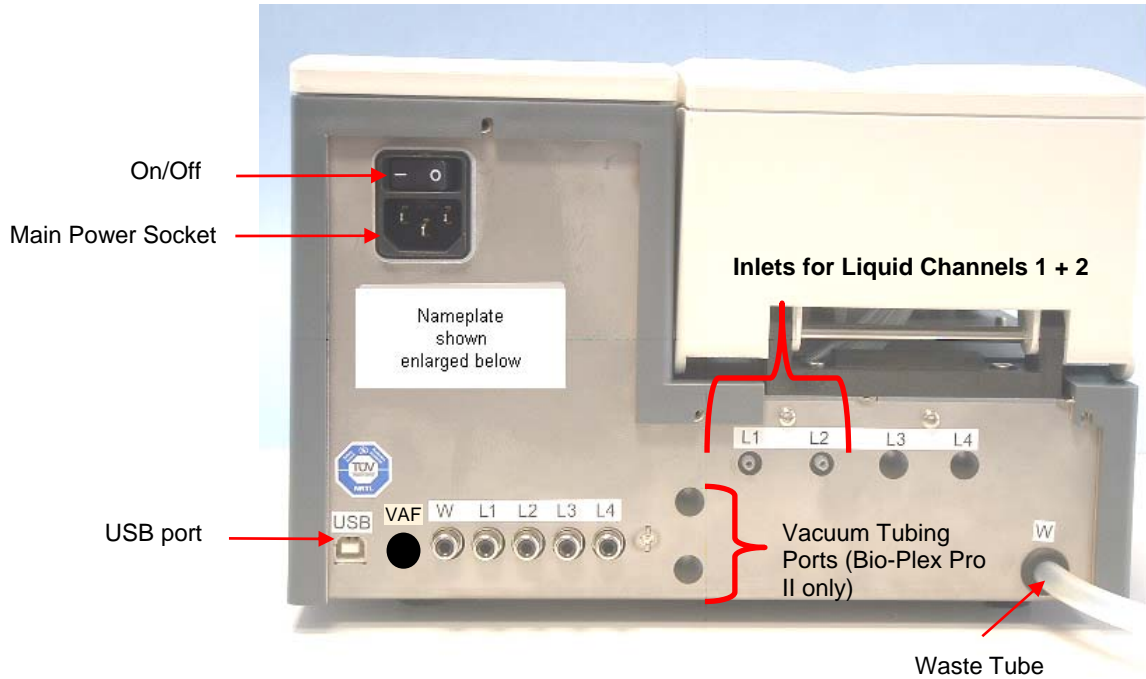

## Instrument Name Plate

The instrument name plate is located under the main power socket. The company information on the top differs, depending upon where it is purchased. The nameplate also shows the model name, the model (part) number, and the serial number.

Use the provided power cord or a similarly-rated replacement cord only.

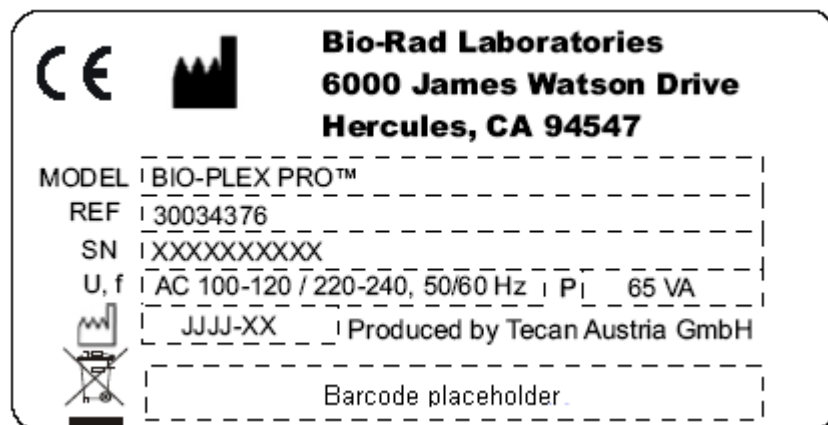

# Detailed Installation

When installing, moving, or connecting the instrument, follow the instructions in this publication. Bio-Rad® Laboratories does not accept the responsibility for injury suffered by anyone attempting these operations without following the instructions in this publication, nor for damage incurred to the instrument.

Make sure the laboratory meets all the requirements and conditions described in this chapter.

## ***Required Working Area***

Select an instrument location that is flat, level, vibration free, away from direct sunlight, and free from dust, solvents, and acid vapors.

Allow at least 10 cm (4 in.) between the instrument and the wall or any other equipment. Do not place any items close to the instrument that could obstruct airflow.

Ideally the liquid bottles should be placed at the same level as the instrument and in plain sight so they can be easily monitored for liquid level. They should not be placed more than 1 m below the level of the instrument since this may result in instrument malfunction.

For information regarding outer dimensions and weight of the instrument, see the Instrument Specifications section on page 30.

## ***Power Requirements***

The instrument is designed to operate at either 100-120 V or 220-240 V.

*No voltage setting is required as the instrument automatically senses the supplied voltage.*

## ***Unpacking and Inspection Checklists***

1. Visually inspect the container(s) for damage before opening.
2. Report any damage immediately.
3. Place the carton in an upright position and open it.
4. Lift the instrument out of the carton and place it in the selected location.
5. Remove the transport protection from the instrument and manifold.
6. Visually inspect the instrument for loose, bent, or broken parts. Report any damage immediately.
7. Compare the serial number on the rear panel of the instrument with the serial number on the packing slip. Report any discrepancy immediately.
8. Check the instrument accessories against the packing list. Save packing materials for further transportation purposes. The instrument must be returned in the original packaging.



The **Bio-Plex Pro** instrument is shipped in one carton, which contains the following important components:

1. Standard plate carrier (installed in instrument)
2. Magnetic carrier
3. A small bag containing
  - a. USB cable
  - b. 2 cleaning needles
4. 2 liquid bottles (2.5 L) with lids
5. 1 waste bottle (5 L) with lid
6. Bundle of 2 tubes for connecting to the liquid bottles (5mm outer diameter; 3mm inner diameter)
7. Main power cable
8. Instrument manual
9. CD with software and support material
10. 10 Bio-Plex Pro flat-bottom plates

The **Bio-Plex Pro II** is also shipped in one carton, and contains everything from the above list, plus:

1. Located in the same small bag indicated in # 3 above. Not needed for Bio-Plex Pro
  - a. Six small screws (two screws are required to attach the Bio-Plex Pro II mounting bracket)
  - b. A Hex Tool.
2. A vacuum plate carrier
3. Vacuum tubing mounting bracket (see page 13)

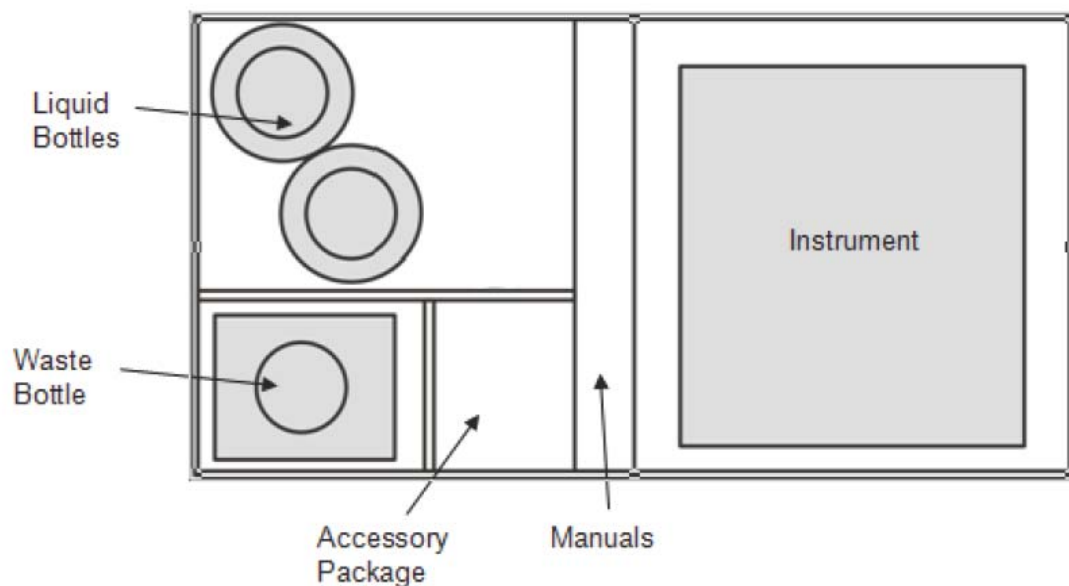

# Detailed Operating Instructions

## Switching the Instrument On

Ensure the instrument has been correctly installed and the main power cable is connected into the main power socket in the rear panel of the instrument and the liquid tubes are connected to the correct liquid and waste bottle(s).

Switch ON the instrument, using the on/off switch in the rear panel of the instrument. The initialization procedure is performed and, depending on the instrument type, the following initialization message is displayed:



If a Rinse procedure was aborted before the instrument was switched off, the following message is displayed after the instrument initializes:



Press OK and then select a Rinse procedure. (Rinse Day will work in all cases.) After the rinsing procedure has been performed, the instrument proceeds to the standby mode and the following message is displayed:



### Caution

The liquid system must be primed before it can be used. Please ensure that the dispensing and aspiration pumps are not run for longer than a few minutes without liquid, otherwise they will be damaged.



### Caution

At the end of each working day, perform the Rinse Night procedure with distilled water to ensure the proper performance of the instrument and to prevent needles from becoming blocked.

## ***Complete Instrument Keypad Functions***

The instrument keypad is used to run and manage wash programs, as well as vacuum filtration programs, to define plate parameters, adjust certain instrument settings, and perform instrument procedures (rinse, prime, and empty prime tray).

The following features are available:

- Preloaded programs for processing Bio-Plex and Bio-Plex Pro assays (also appropriate for other standard and magnetic xMAP assays)
- 20 user definable washing programs, stored under program positions 1 to 20
- Up to 60 processing steps per program; each processing step can be identical or different from the previous step
- Adjustable soak time (1 second to 60 minutes and 59 seconds)
- Variable shaking settings:
  - High: Linear shaking with a shaking frequency of 25 Hz and a shaking amplitude of 1 mm
  - Medium: Linear shaking with a shaking frequency of 10 Hz and a shaking amplitude of 2 mm
  - Low: Linear shaking with a shaking frequency of 5 Hz and a shaking amplitude of 3 mm
- Adjustable dispense rate (drip mode to 500 µl/s)
- Adjustable aspirating speed (1 to 3)
- Adjustable bottom positions (bottom, custom, overflow)
- Two rinse modes (Rinse Day and Rinse Night) can be used to select how the instrument is rinsed before it is left to stand or switched off
- Automatic microplate centering, before starting any wash program
- Programmable strip selection, before starting the washing procedure



**Alphabetical list of LCD text with explanations**

DISPLAY	Meaning...
ASP.RATE #	Aspiration rate #
ASPIRATE	Aspirate
BOTTOM POS.	Bottom position
BUBBLE ERROR	Bubble error
BUBBLE HIGH	Bubble high
BUBBLE LOW	Bubble low
BUBBLE MEDIUM	Bubble medium
BUBBLE OFF	Bubble OFF
BUBBLE SENSOR	Bubble sensor
BURN IN TEST	Burn in test
C# CYCLE	C# Cycle
C# CYCLEEND	C# Cycle End
C# P# ASP	C# P# Aspirate
C# P# CYCLE	C# P# Cycle
C# P# CYCLEEND	C# P# Cycle end
C# P# DISP	C# P# Dispense
C# P# SOAK	C# P# Soak
C# P# USER PR.	C# P# User Prompt
C# P# VAC.	C# P# Vacuum
C# P# WASH	C# P# Wash
CH# PRIMED?	Channel# primed?
CHANNEL #	Channel #
CLEAN NO	No cleaning
CLEAN YES	Cleaning
CLEAR	Clear
CLEAR: #	Clear: #
CLR	Clear
CLR CHANNEL 1	Clear channel 1
CLR CHANNEL 2	Clear channel 2
CLR CHANNEL 3	Clear channel 3
CLR CHANNEL 4	Clear channel 4
CLR VAC.WASTE	Clear vacuum waste
CLR WASTE 1	Clear waste 1
Crossw.Asp NO	Crosswise Aspiration no

DISPLAY	Meaning...
Crossw.Asp YES	Crosswise Aspiration yes
CYCLE NO #	Cycle number #
CYCLE NO #	Cycle number #
DEFINE EDIT	Define Edit
Disable High VAC	Disable high vacuum
Disable Low VAC	Disable low vacuum
DISABLE PC	Disable Process Control
DISABLE VAC	Disable vacuum
DISPENSE	Dispense
DISPENSE POS.	Dispense position
EDIT LLD CHANNEL	Edit LLD channel
EDIT PLATES	Edit plates
EMPTY BOTTLES	Empty bottles
EMPTY PRIMETRAY	Empty prime tray
Enable High VAC	Enable high vacuum
Enable Low VAC	Enable low vacuum
ENABLE PC	Enable Process Control
ENABLE VAC	Enable vacuum
FINAL ASP?	Final aspiration?
FINAL ASPIRATE	Final aspiration
FL.RATE # ul/s	Flow rate # ul/s
FL.RATE DRIP	Flow rate Drip
HPC SYSTEM ERR	Hydro Process Control System error
H-SPEED # mm/s	Head speed: # mm/s
INIT	Initialize
INIT ERROR	Initialization error
INV CMD	Invalid command
INV PARAMETER	Invalid parameter
LIQUID BOTTLE OK	Liquid bottle OK
LLD ERROR	LLD Error
LLD OFF	LLD OFF
LLD ON	LLD ON
LOCKED	locked

## Defining New Programs

DISPLAY	Meaning...
MANIFOLD BROKEN	Manifold broken
MANIFOLD DETECT	Manifold detection
MANIFOLD UP	Manifold up
MISS. PARAMETER	Missing parameter
MOVE CUSTOM	Move custom
MOVE MANIFOLD	Move manifold
MOVE OVERFLOW	Move overflow
MOVE TRANSPORT	Move transport
NAME:	Name:
NO ASP AT VACFIL	No aspiration at vacuum filtration
NO PLATE	No plate
NO PLATE FOUND	No plate found
NO PROGRAM	No Program
NO PROGRAM FOUND	No program found
NO VACFIL	No vacuum filtration
NO.OF CYCLES #	Number of cycles #
NOT DEF	Not defined
OPTIONS	Options
OVERFLOW POS.	Overflow position
PARAMETER RANGE	Parameter range
PC ASP ERR	Process Control Aspiration error
PC DISP ERR	Process Control Dispense error
PC FUNCT. ERR	Process Control Function error
PLATE	plate
Plate #	Plate #
PLATE INSERTED?	Plate inserted?
PLATE MODE	Plate mode
PLEASE EMPTY	Please empty
PLEASE INSERT	Please insert
PLEASE RINSE	Please rinse
POS. ASP1	Position Aspirate 1
POS. ASP2	Position Aspirate 2

DISPLAY	Meaning...
POWERFAILURE	Power failure
PRIME	Prime
PRIME EXIT YES	Prime Exit Yes
PRIME SOL. OK?	Prime solution OK?
PROCEDURES	Procedures
PROCESS CONTROL	Process Control
PROGR # DELETED	Program # deleted
PROGR #:	Program #:
PROGRAM	Program
PROGRAM END?	Program End?
PROGRAM IS	Program is
REMOTE	Remote
REMOVE PLATE	Remove Plate
RINSE	Rinse
RINSE DAY	Rinse day
RINSE NIGHT	Rinse night
RINSE SOL. OK?	Rinse solution OK?
RS485 TIMEOUT	RS485 Timeout
RUN #	Run #
SENSOR DEFECT	Sensor defect
SET CHANNEL 1	Set channel 1
SET CHANNEL 2	Set channel 2
SET VAC.WASTE	Set vacuum waste
SET WASTE 1	Set waste 1
SETTINGS	Settings
SHAKE HIGH	Shake high
SHAKE LOW	Shake low
SHAKE MEDIUM	Shake medium
SHAKE OFF	Shake off
SHAKE YES	Shake yes
SHOW	Show
SOAK	Soak
START	Start
STEPLOSS	Steploss

DISPLAY	Meaning...
STRIP MODE	Strip mode
TIME	Time
TIME: # s	Time: # s
TIME: #min #s	Time: #min #s
USE OTHER NAME	Use other name
USER PROMPT	User prompt
VAC CHAMB.RINS	Vacuum chamber rinsing
VAC NOT READY	Vacuum not ready
VAC NOT STARTED	Vacuum not started
VAC.	Vacuum
VACUUM CLEAN	Vacuum clean
VACUUM FILTR.	Vacuum filtration

VACUUM PREPARE	Vacuum prepare
VACUUM STOP	Vacuum stop
VACUUMFILTRATION	Vacuum filtration
VOLUME	Volume
VOLUME # ul	Volume # ul
WASH	Wash
WASTE BOTTLE OK?	Waste bottle OK?
WASTEBOTTLE	Waste bottle
Y-User Def #	Y-User Defined #
Z-POS: BOTTOM	Z-POS: Bottom
Z-POS: CELL	Z-POS: Cell
Z-POS: CUSTOM	Z-POS: Custom
Z-POS: OVERFLOW	Z-POS: Overflow
Z-POS:MOVE CUST.	Z-POS: Move customer
Z-POS:MOVE OVER.	Z-POS: Move overflow
Z-User Def #	Z-User Defined #

## Defining Custom Wash Programs

The following instructions are for defining custom programs. The programs needed for Bio-Plex or other xMAP assays are pre-installed on your wash station. No further programs are needed unless your assay has unique needs. Access the pre-loaded programs as described on pages 18 and 19.

The operating procedure is dependent on the instrument options and the program settings.



### Caution

Be careful that the plates are positioned in the microplate reader as selected in the program, otherwise spilling can occur and the instrument may become contaminated.



### WARNING

When the instrument is busy, do not touch the manifold!  
After the instrument has been used, the manifold and prime tray may be infectious!

## Wash Modes

The instrument can wash a microplate using the following wash modes:

<b>Plate Mode</b>	Each program step is performed on all of the selected strips of a microplate sequentially, before proceeding to the next step. The entire plate or the defined plate range is processed for the defined soaking time.
<b>Strip Mode</b>	The entire wash program is performed on one strip of a microplate before proceeding to the next strip. The strip is processed for the defined soaking time, before proceeding to the next strip or group of strips.



## Washing Positions

Wash, dispense, and aspirate steps can be defined in a wash program with the following Z-positions:

<b>Overflow</b>	For ELISA assays and cellular assays. Overflow washing consists of a simultaneous aspiration and dispense step. It creates a circular flow of wash buffer in the well and ensures that the topmost parts of the well are also washed.
<b>Bottom</b>	For ELISA assays.
<b>Custom</b>	Any necessary washing position can be selected; the custom positions are not saved as *.pdf files in comparison to the overflow and bottom position.
<b>Move Overflow</b>	If Move Overflow (MOVE OVER) is selected, the manifold moves step-wise from the bottom position to the Overflow position during dispensing. It is recommended for cell wash applications or any applications which must be treated with care.
<b>Move Custom</b>	If Move Custom (MOVE CUST.) is selected, the manifold moves step-wise from the bottom position to the user-defined Custom Z- position during dispensing. It is recommended for cell wash applications or any applications which must be treated with care.

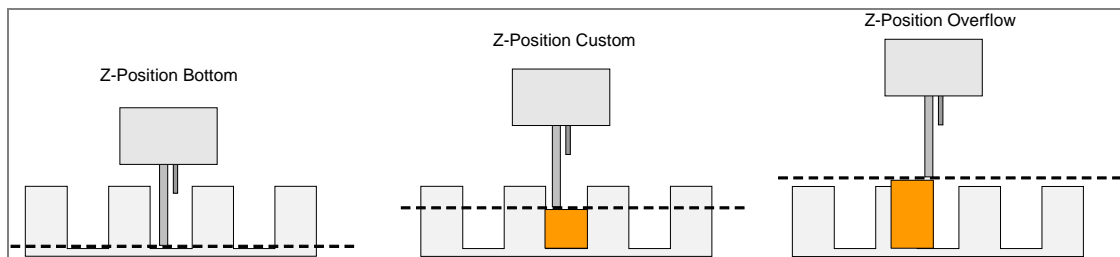

Wash Position Diagrams

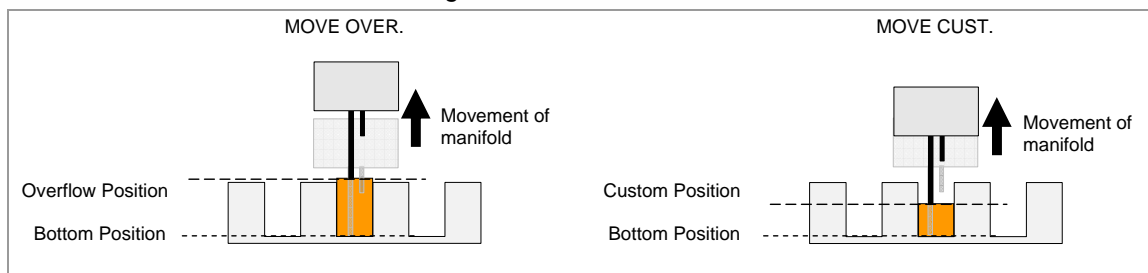

Movement Diagrams for Z-positions with MOVE

## Aspirating Modes

To improve wash efficiency and reduce the residual volume, the manifold must be positioned so that the aspirating needles are correctly positioned in the wells for round-bottom, V-shaped bottom, or flat-bottom well microplates.

### Normal Aspiration Mode

For round-bottom or V-shaped bottom wells, the aspirating needles are placed in the middle of the wells. Only one aspiration position can be selected.

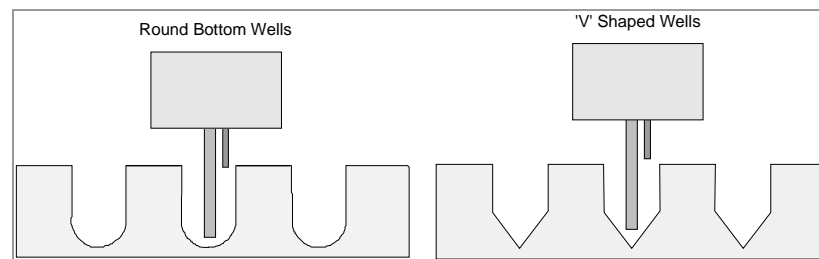

Normal Aspirating Positions

### Crosswise Aspiration Mode

With flat bottom wells, the instrument can perform crosswise aspiration using two aspiration positions per well.

The aspirating needles are set at two positions on the bottom of the wells (front edge and back edge).

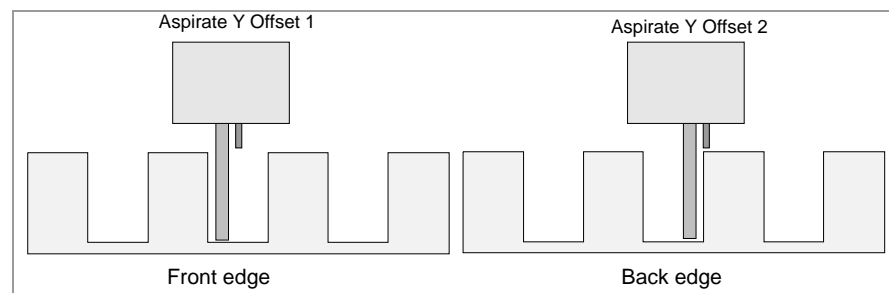

Crosswise Aspiration for Flat Bottom Wells

## Drip Mode

The slowest dispensing mode is the drip mode. This mode is not recommended for xMap or Bio-Plex applications.

Drip mode is used for very sensitive applications, e.g. washing cell layers, because the instrument offers the possibility to dispense liquid in small drops. This minimizes the detachment of cells and increases the remaining cell percentage at the bottom of the wells.

The following example shows a typical wash program for working with adherent cells as it would appear in the Define/Edit menu. See Define/Edit a Program on page 49 for further information about defining programs.



**Note**

***The following example program should not be used as a standard wash procedure for cell washing as it is necessary to adjust the wash parameters, such as Z-position "MOVE CUST.", dispensing and aspirating rates, head speed, etc., according to the cell type used.***

## Defining New Programs

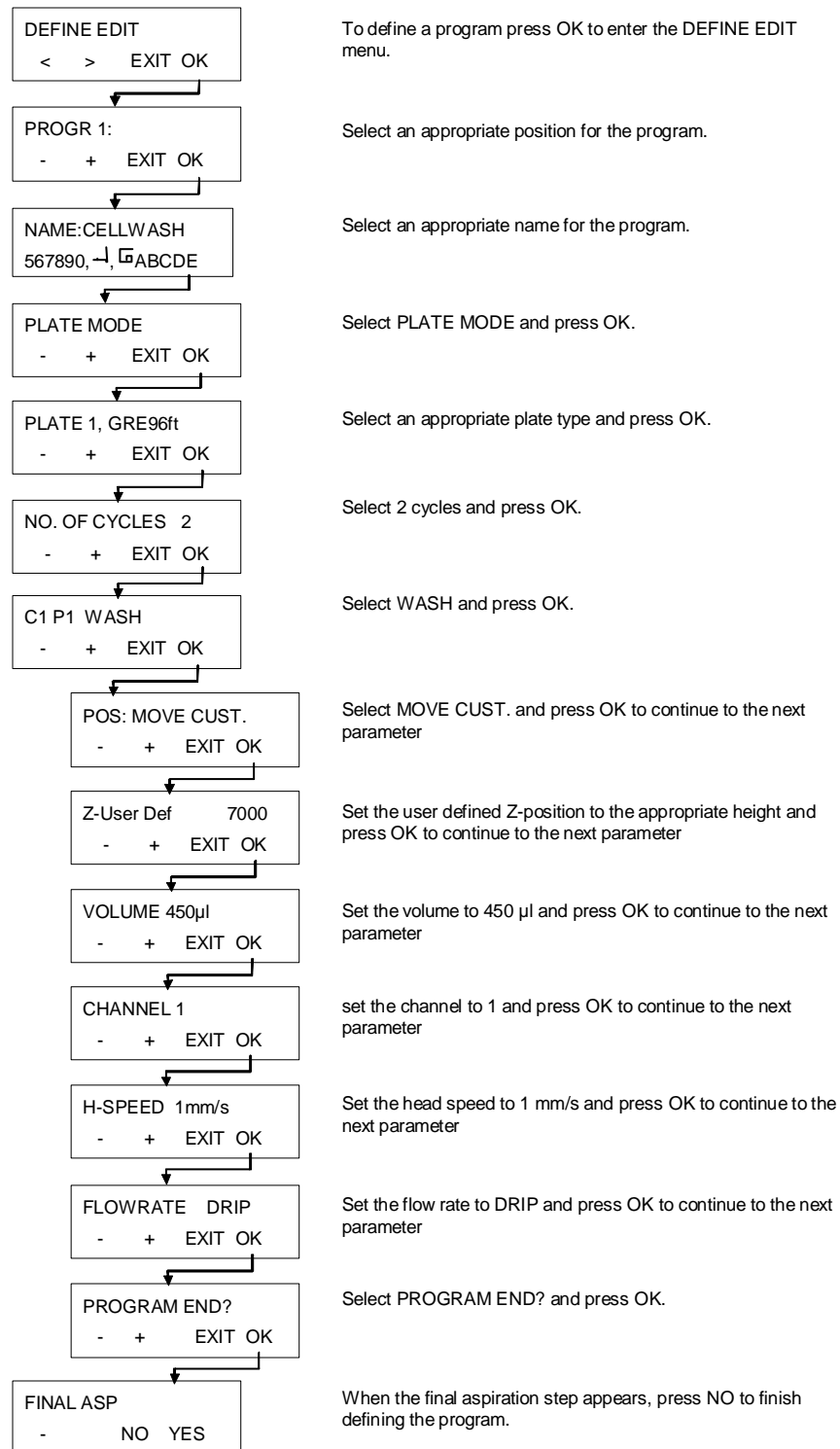

Example of a typical wash program for working with adherent cells

# Defining New Programs

## Introduction

The following program items are available:

<b>CYCLE:</b>	The number of cycles the subsequent processing steps should be performed
<b>ASP:</b>	An aspirate step removes liquid from the wells
<b>DISP:</b>	A dispense step fills the wells with liquid
<b>WASH:</b>	Liquid is dispensed and aspirated simultaneously creating a circular flow with a maximum volume of 3000 µl in one wash step for increased wash efficiency
<b>SOAK:</b>	During a soak step the liquid remains in the wells for the set time (with or without shaking)
<b>VAC:</b>	For collecting desired substances by vacuum filtration using filtration plates
<b>USER PROMPT:</b>	User interaction is requested
<b>FINAL ASPIRATE:</b>	An aspirate step at the end of a program
<b>END PROGRAM:</b>	The program finishes

## Program Menu

The **Program** menu has the following options:

<b>Start</b>	Run a defined wash program
<b>Define/Edit</b>	Define or edit a program on the instrument
<b>Show</b>	View the parameters of a defined program
<b>Clear</b>	Clear a wash program from the instrument's menu

The **Program** menu has the following structure:

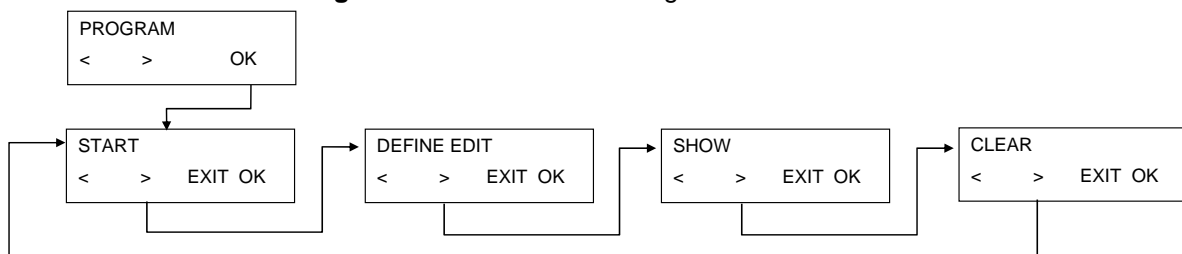

## Define/Edit a Program

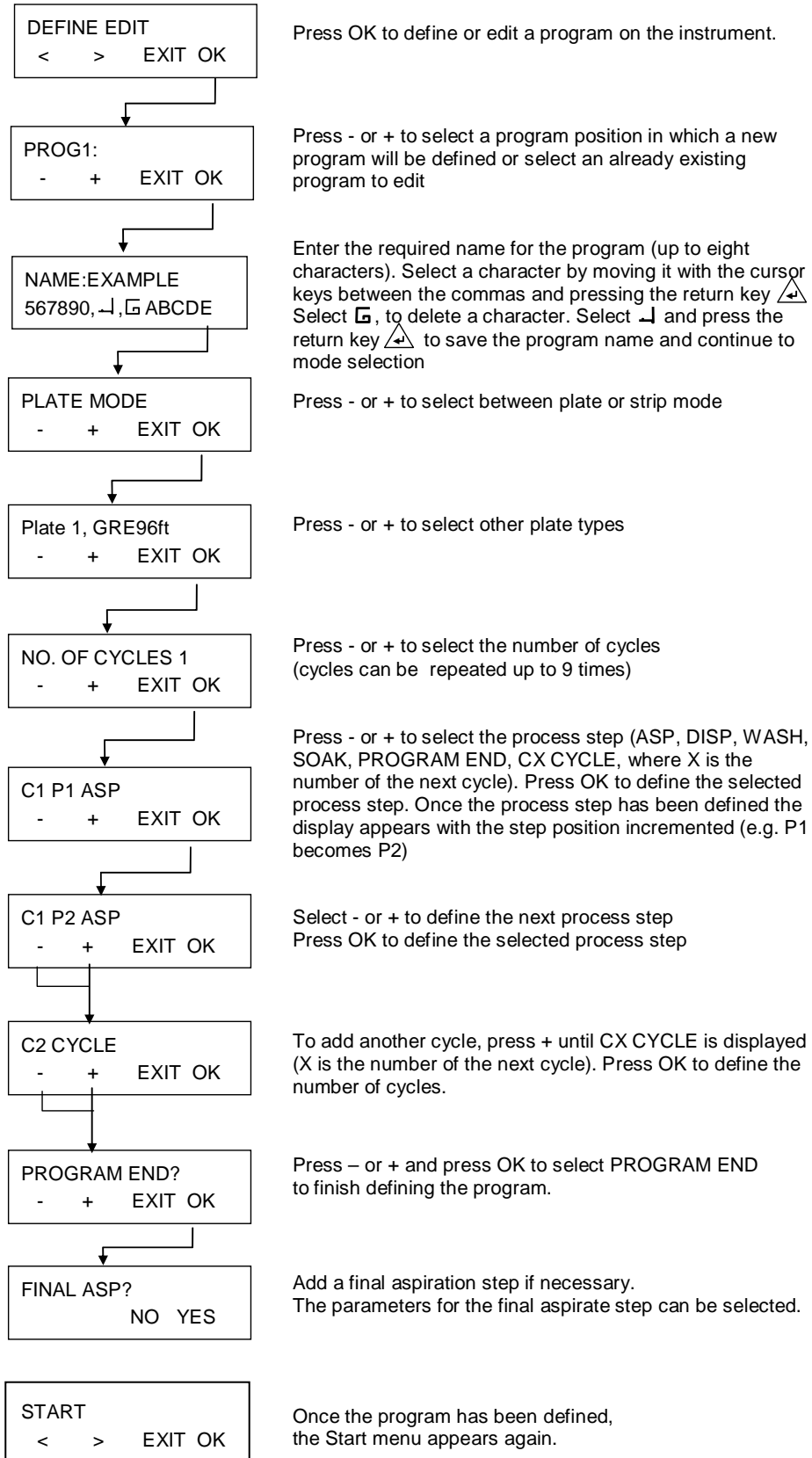

## Process Step: Aspirate

CX PX ASP  
- + EXIT OK

Select and confirm aspirating step (ASP)  
CX = Cycle Number  
PX = Program Step Number

Crossw.Asp YES  
- + EXIT OK

Select YES using – or + to perform crosswise aspiration or select NO to perform normal aspiration.

POS: BOTTOM  
- + EXIT OK

Press – or + to select the aspiration position (BOTTOM; OVERFLOW or CUSTOM).

TIME: 4 s  
- + EXIT OK

Select required aspirating time (1 - 20 seconds).

H-SPEED10mm/s  
- + EXIT OK

Select required aspirating speed (1 - 20 mm/sec).

ASP.RATE 2  
- + EXIT OK

Select required aspirating rate (1 - 3), where 1 is the weakest and 3 the strongest rate.

CX PY ASP  
- + EXIT OK

After the process step has been defined the initial display appears.  
CX = Cycle Number  
PY = Program Step Number incremented by 1  
Press OK to define another aspiration step or press – or + to select the next program step, Program End or a new cycle.



**Note**

**Low residual volumes cannot be guaranteed if not all wells in a strip are filled with liquid. To prevent cross contamination, the head speed should be lowered.**

## Aspiration Position Diagrams

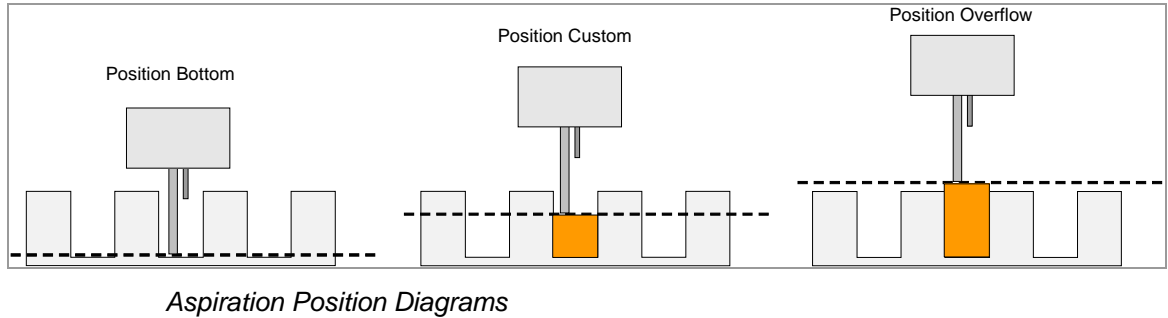

## Process Step: Dispense

CX PX DISP  
- + EXIT OK

Select and confirm dispensing step (DISP)  
CX = Cycle Number  
PX = Program Step Number

Z-POS: OVERFLOW  
- + EXIT OK

Select required dispensing position  
(OVERFLOW, CUSTOM, MOVE OVER.,  
MOVE CUST. or BOTTOM).

VOLUME 300µl  
- + EXIT OK

Select the volume of solution to be used  
(50 - 400 µl in increments of 50 µl).

CHANNEL 1  
- + EXIT OK

Select the channel to be used (1 - 4)  
depending on instrument configuration.

FL.RATE 300 µl/s  
- + EXIT OK

Select required flow rate (drip to 500µl/sec).

CX PY DISP  
- + EXIT OK

After the process step has been defined the initial display appears.  
CX = Cycle Number  
PY = Program Step Number incremented by 1  
Press OK to define another dispense step  
or press - or + to select the next program step,  
Program End or a new cycle.



## Dispensing Position Diagrams

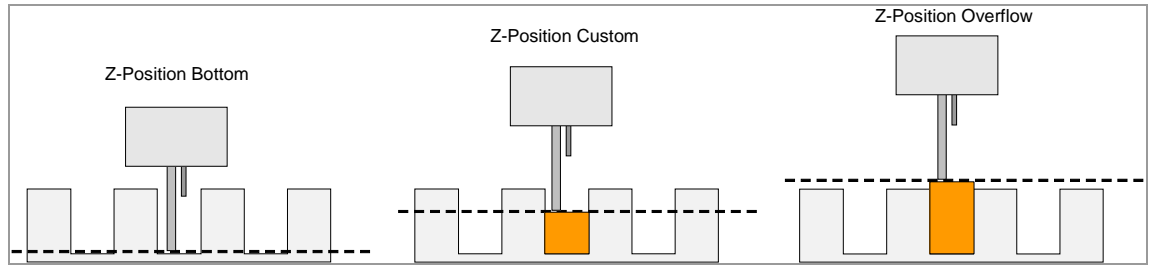

*Position Diagrams*

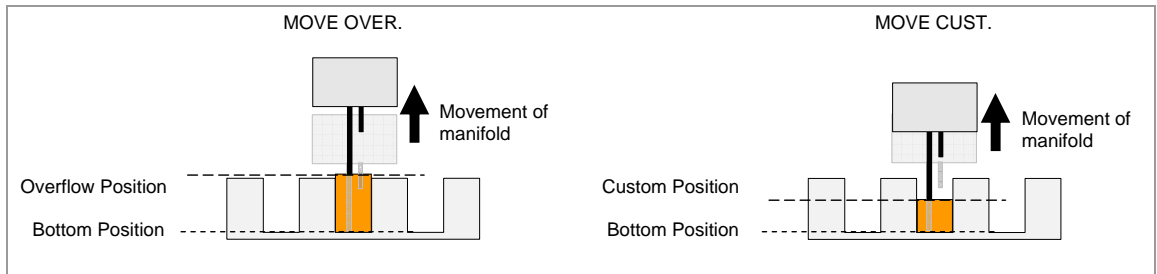

*Movement Diagrams for Z-positions with MOVE*

## Process Step: Wash

This process step is used to aspirate solution out of the wells and simultaneously dispense and aspirate the solution.

CX PX WASH  
- + EXIT OK

Select and confirm wash step (WASH)  
CX = Cycle Number  
PX = Program Step Number

CROSSW. ASP. NO  
- + EXIT OK

Select **Yes** using – or + to perform aspiration of wash crosswise or select **No** to perform normal aspiration.

POS: OVERFLOW  
- + EXIT OK

Select required dispensing position (OVERFLOW, CUSTOM, MOVE OVER., MOVE CUST. or BOTTOM).

VOLUME 300µl  
- + EXIT OK

Select the volume of solution to be used (50 - 3000 µl in increments of 50 µl)

CHANNEL 1  
- + EXIT OK

Select the channel to be used (1 - 4) depending on instrument configuration.

H-SPEED 10 mm/s  
- + EXIT OK

Select required aspirating speed (1 - 20 mm/sec).

FL.RATE 200 µl/s  
- + EXIT OK

Select required flow rate (drip to 500µl/sec).

ASP. RATE 2  
- + EXIT OK

Select required aspirating rate (1 – 3).

TIME 1 s  
- + EXIT OK

Select required aspirating time (1 – 20 mm/s).

CX PY WASH  
- + EXIT OK

After the process step has been defined the initial display appears.  
CX = Cycle Number  
PY = Program Step Number incremented by 1  
Press OK to define another wash step or press – or + to select the next program step, Program End or a new cycle.

## Process Step: Soak

CX PX SOAK  
- + EXIT OK

Select and confirm soak step (SOAK).  
CX = Cycle Number  
PX = Program Step Number

TIME: 0 min 10 s  
- + Chg. OK

Select required soaking time using +/- keys  
(0 – 60 min; 1 - 59 seconds )  
Press Chg. to select minutes or seconds.

SHAKE OFF  
- + EXIT OK

The shaking speed can be selected  
(OFF, LOW, MEDIUM or HIGH).

CX PY SOAK  
- + EXIT OK

After the process step has been defined the initial display appears.  
CX = Cycle Number  
PY = Program Step Number incremented by 1  
Press OK to define another soak step or press – or + to select the next program step, Program End or a new cycle.

## Process Step: User Prompt

CX PX USER PR.  
- + EXIT OK

Select and confirm User Prompt strip on required position in current program.

## Process Step: Vacuum Filtration

CX PX VAC  
- + EXIT OK

Select and confirm Vacuum Filtration step (VAC).  
CX = Cycle Number  
PX = Program Step Number

VAC. -100.0 mBar  
- + EXIT OK

Select required vacuum pressure using the -/+ keys.

TIME: 0 min 10 s  
- + Chg. OK

Select required soaking time using the -/+ keys  
(0 – 60 min; 1 - 59 seconds )  
Press Chg. to select minutes or seconds.

CX PX ASP  
- + EXIT OK

After the process step has been defined the initial display appears.  
CX = Cycle Number  
PY = Program Step Number incremented by 1  
Press OK to define another vacuum filtration step or press – or + to select the next program step, Program End or a new cycle.



**Note-Adjust parameters for filtration plates only when vacuum filtration is enabled!**

## Show Program

This submenu is used to display the parameters that have been defined for a program. An example wash program containing one cycle, one wash step, and a final aspiration step will be used to demonstrate this menu.

The displayed parameter settings cannot be altered in this submenu.

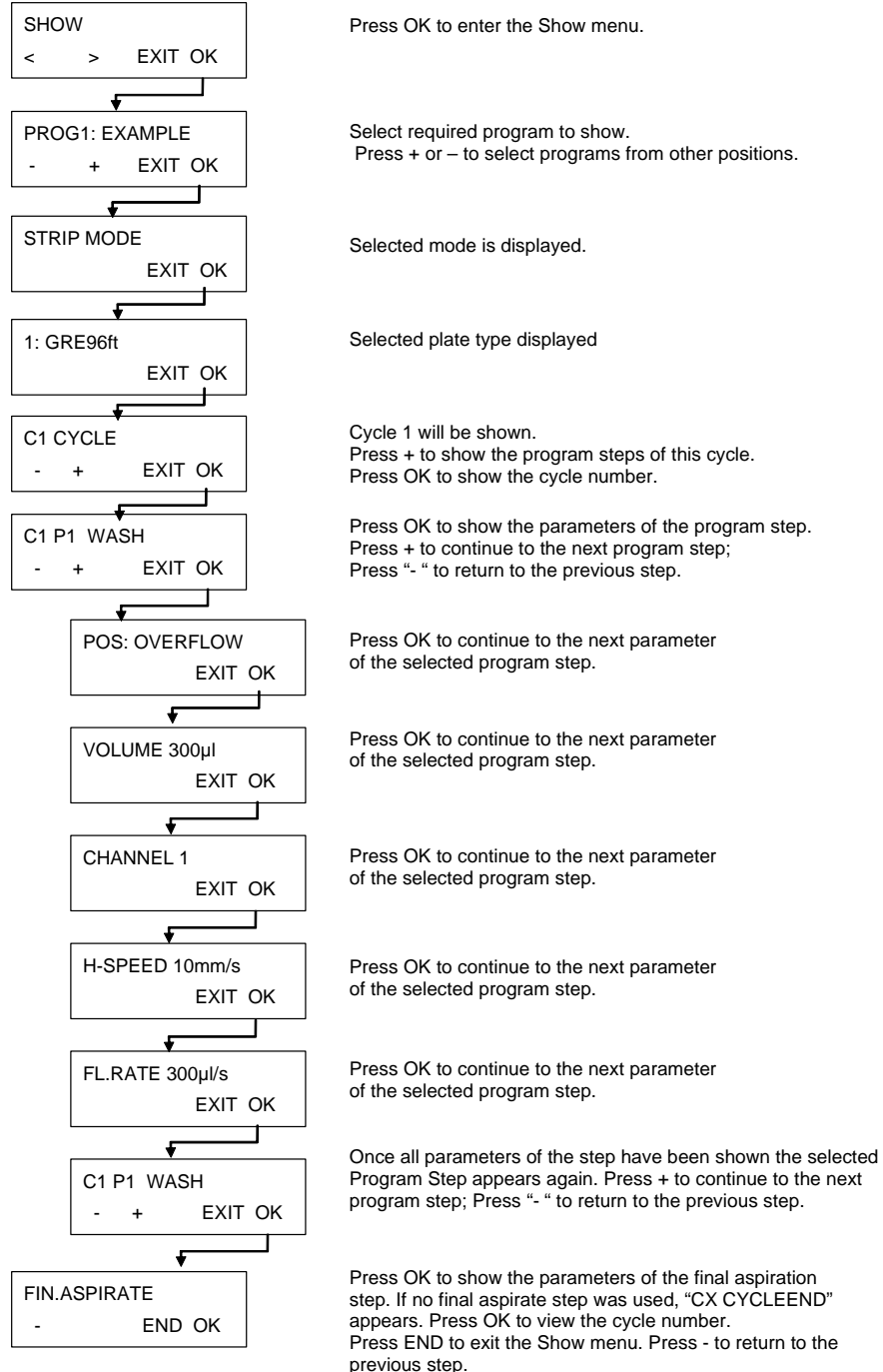

## Clear Program

This submenu is used to clear a program from the instrument's memory.

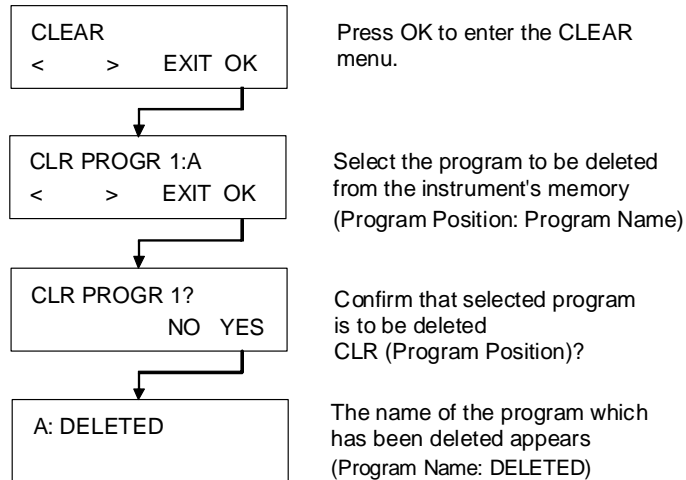

If the program is locked it cannot be cleared and the following message is displayed:

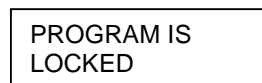

The program can only be unlocked via the HydroControl software, by users with the appropriate rights.

## Settings Menu

The Settings menu has the following options:

- Edit Plates** Adjustment procedure for setting the parameters for up to 20 different microplates.
- Options** The **Settings** menu contains the following submenus: **Edit LLD Channels, Vacuum Filtration, Process Control.**
- Bubble Sensor** The **Bubble Sensor** sensitivity can be set to **Low, Medium,** or **High** depending on liquids used (if this option is installed). If very foamy liquids are used the bubble sensor should be switched **OFF**.

The **Settings** menu has the following structure:

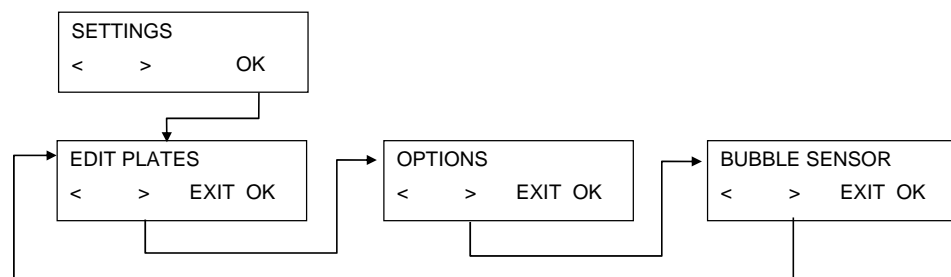

## Edit Plates

**Predefined Bio-Plex plate definitions should not be edited!**



Press OK to continue.

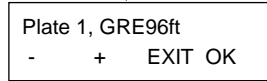

Press – or + to select the plate (1-20) and press OK to edit the plate parameters.



Use the cursor keys to select the position to be defined (OVERFLOW, BOTTOM, ASP1 or ASP2) and press OK. For round and V-shaped bottom plates, only one aspiration can be defined.

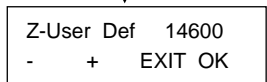

The instrument moves to the predefined position. Use the – and + keys to change the position. Confirm with OK. The next position can then be selected.

Press OK to save the defined position; Press EXIT to leave the menu without saving the position. The instrument moves to the home position and the firmware returns to the Edit Plates menu.

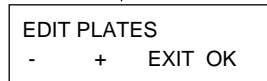

## Options Submenu

The **Options** submenu has the following structure:

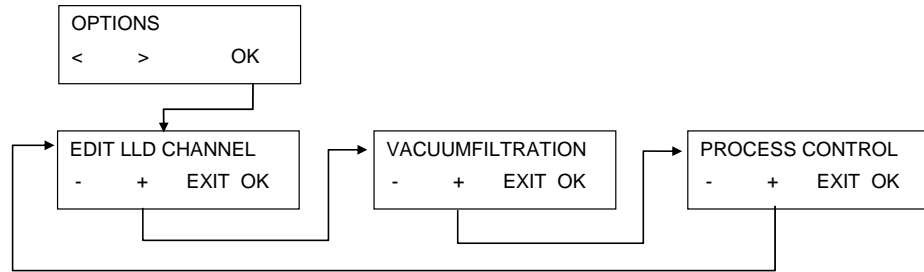

## Vacuum Filtration

See Page 18. Enabling/Disabling Vacuum.



**Note**

**Make sure that the vacuum transport is mounted when the vacuum filtration option is enabled.**

## Bubble Sensor

It is recommended that the Bubble Sensor be left off.

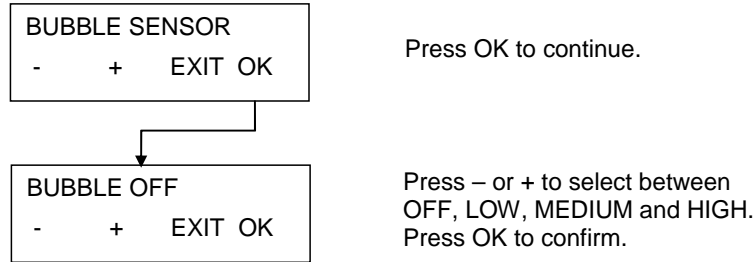

## Procedures Menu

The **Procedures** menu has the following options:

<b>Rinse</b>	Start rinse procedures.
<b>Prime</b>	Start prime procedures.
<b>Empty Prime Tray</b>	Aspirate liquid out of the prime tray.
<b>Vacuum Filtration</b>	Prepare the vacuum pressure to prevent delays during the running of a wash program.

The **Procedures** menu has the following structure:

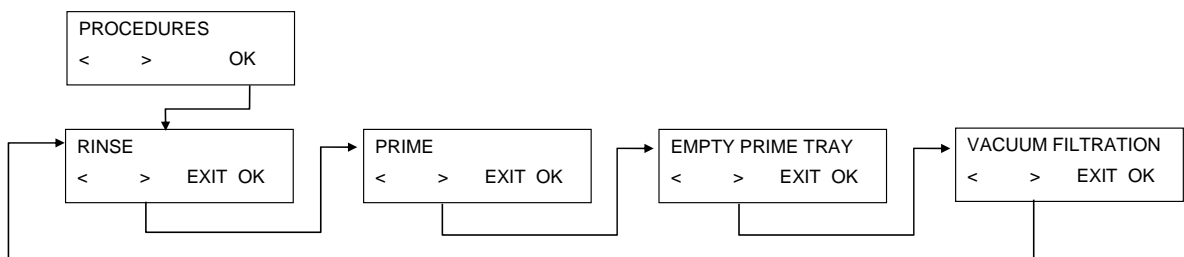

### Rinse

For details, see the Rinse section on page 24.

### Prime

For details, see Priming the Instrument on page 20.

### Empty Prime Tray

Navigate to empty EMPTY PRIME TRAY in the Procedures and Press OK. The prime tray will be aspirated.





# Maintenance and Cleaning

## *Cleaning Procedures*



### **WARNING**

All parts of the instrument that come into contact with potentially infectious material must be treated as potentially infectious areas.

It is advisable to adhere to applicable safety precautions, (including the wearing of powder-free gloves, safety glasses and protective clothing) to avoid potential infectious disease contamination when performing cleaning procedures and also when making adjustments to the instrument.

The most important cleaning procedure for this instrument is to rinse the liquid system with distilled water before the instrument is left to stand, or switched off at the end of each day.

The manifold should be removed and cleaned thoroughly at least once every six months, or whenever one or more of the needles are blocked.

## *Cleaning the Cover and Display*

The outer surface of the instrument and the display may be cleaned periodically using a tissue moistened with a mild detergent solution.



### **Caution**

Never use acetone, as it will damage the covers.

## *Cleaning the Liquid System*

To clean the liquid system, perform Rinse and Prime procedures as described in the Basic Operation and Maintenance section.



### **Caution**

If the manifold is not rinsed, the needles will become blocked. If this occurs, the manifold will need expensive repairs or will have to be replaced.

### ***Cleaning the Manifold***

**The manifold can be cleaned using:**

- The supplied cleaning needles (accessory box). The small cleaning needle is for the dispensing needles, and the large cleaning needle is for the aspirating needles. Carefully push the cleaning needles into the aspirating and dispensing needles. Rinse the manifold block with distilled water to ensure that all particles have been removed.
- A gentle ultrasonic bath of warm distilled water for 15 minutes (max. five times, manifold must be removed from the instrument).
- Autoclaving (max. 130°C, max. five times, manifold must be removed from the instrument.)

**Do not autoclave manifolds with the Process Control option!**

- Reinstall the manifold if necessary (see page 66).
- After the manifold has been cleaned, switch the instrument on and perform the priming procedure using distilled water.

### ***Cleaning Waste Bottles***

Before cleaning the waste bottles, empty the bottles according to local disposal regulations.

The bottles must be cleaned regularly depending on the applications, using a mild detergent.



**WARNING**

**When handling waste bottles, it is advisable to adhere to applicable safety precautions (including wearing powder-free gloves, safety glasses, and protective clothing) to avoid potential infectious disease contamination.**

## Liquid or Foam Spills



### WARNING

Always switch off the instrument before removing any kind of spills on the Instrument.

All spills (liquid or foam) must be treated as potentially infectious. Therefore, always adhere to applicable safety precautions, (ncluding wearing powder-free gloves, safety glasses and protective clothing) to avoid potential infectious disease contamination.

Additionally, all resulting waste from the clean-up must be treated as potentially infectious and the disposal must be performed according to local regulations.

If the spill occurs in the instrument, a service technician is required.

Spilling of liquid or foam may occur when the Instrument is operated improperly, such as:

- Microplate used does not match installed manifold.
- The strip plate positions do not match the positions defined in the program used for processing.
- Plate parameters are not properly adjusted.
- Waste bottle not emptied when liquid level or foam level reaches maximum filling level.
- No anti-foaming agent used with wash buffers showing strong tendency to foam.
- Always remove spills immediately after they have occurred. Use paper tissue to soak-up spills and wipe surface dry.



### WARNING

#### WASTE BOTTLE - LIQUID LEVEL

Make sure that the liquid level of the waste bottle is always kept below the maximum level indicated on the bottle to avoid potential overflow.

The contents of waste bottle are potentially infectious, so it is important to wear protective clothing (gloves, lab coat, and safety glasses) when emptying OR handling a waste bottle.

## Replacing the Manifold

The Instrument is delivered with the manifold already installed. The manifold drawing below shows the basic components.

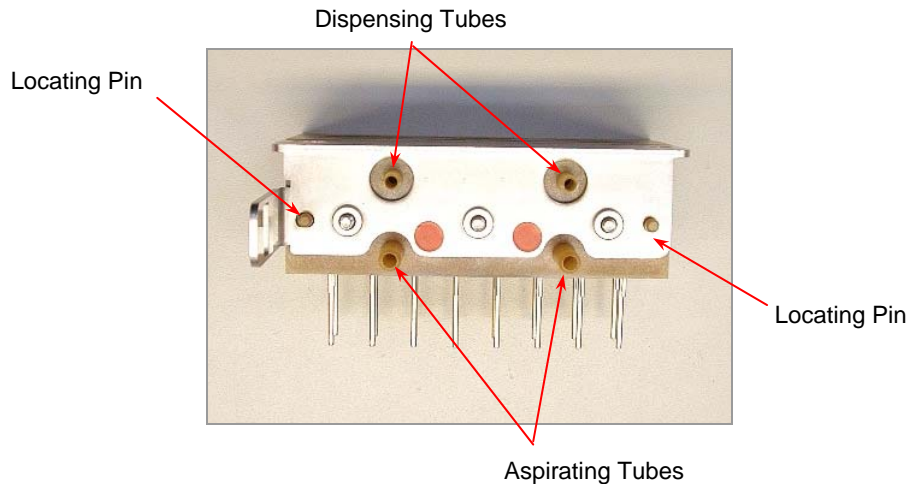

*The Rear of the Manifold*



**Note**

*Always wear powder-free gloves when handling the manifold.*



**WARNING**

**After the instrument has been used, the manifold may be infectious!**

**Before the manifold is removed it must be thoroughly disinfected.**

**It is advisable to adhere to applicable safety precautions, (including the wearing of powder-free gloves, safety glasses, and protective clothing) to avoid potential infectious disease contamination.**



**WARNING**

**Prime the instrument without liquid to empty all liquid from the system, before removing the manifold.**

## Removing the Manifold



### WARNING

Prime without liquid to remove liquids from the tubing system.

The manifold should be removed and thoroughly cleaned at least once every 6 months or whenever needles become blocked.

1. Lift the manifold arm and remove the black manifold arm guard plate by removing the three screws using the Allen key provided.

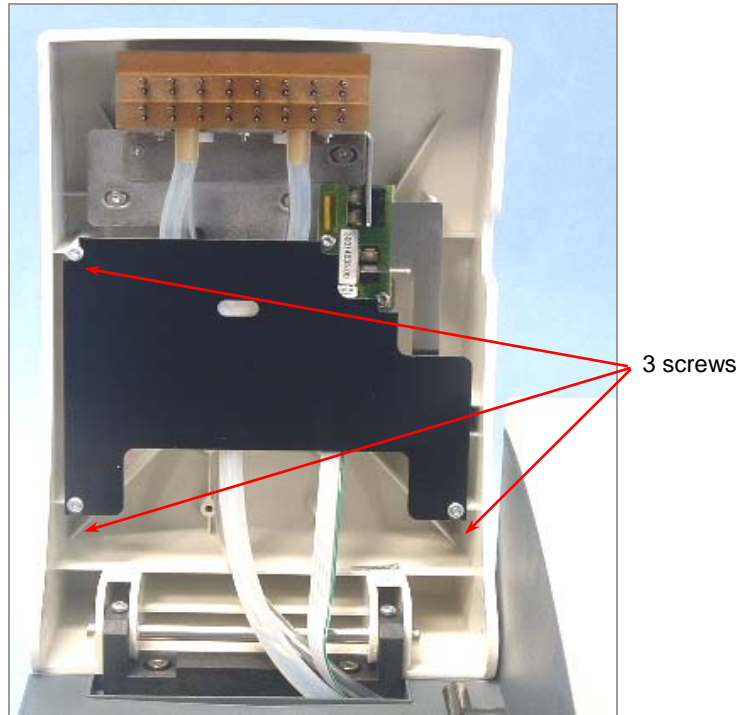

2. Lift the manifold arm and remove the two screws that attach the manifold to the instrument using the Allen key provided.

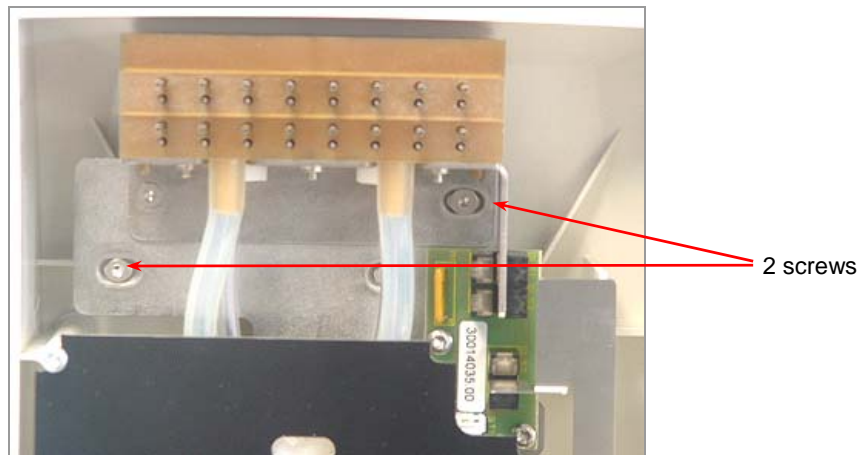

3. Carefully pull the tubing off the connectors on the rear of the manifold and remove the manifold.

### ***Installing the Manifold***

The standard manifolds are installed using the following procedure:

1. Lift the manifold arm.
2. Carefully fit the manifold onto the manifold arm and ensure that the locating pins are correctly inserted through the holes in the bracket.

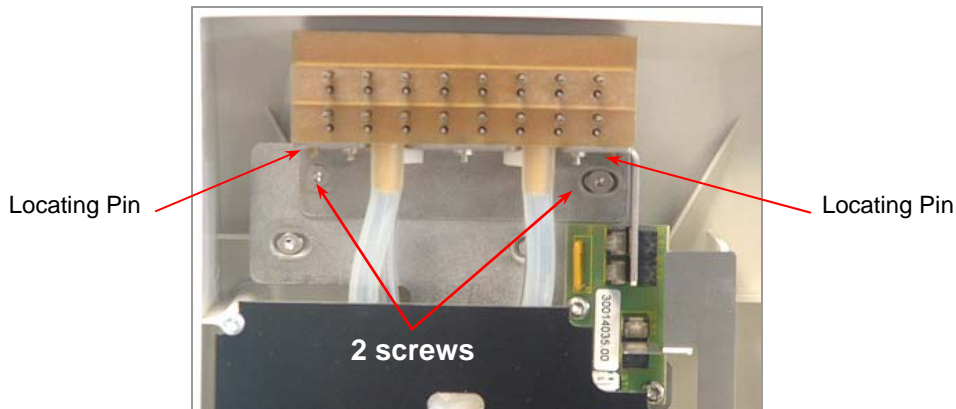

3. Tighten the manifold into place using the two screws using the Allen key provided.
4. Fit the dispensing tubes (marked blue) onto the top connector on the rear of the manifold.
5. Fit the aspirating tubes (marked red) onto the two bottom connectors on the rear of the manifold (marked with red labels).
6. Attach the black manifold guard plate with the 3 screws using the Allen key provided.

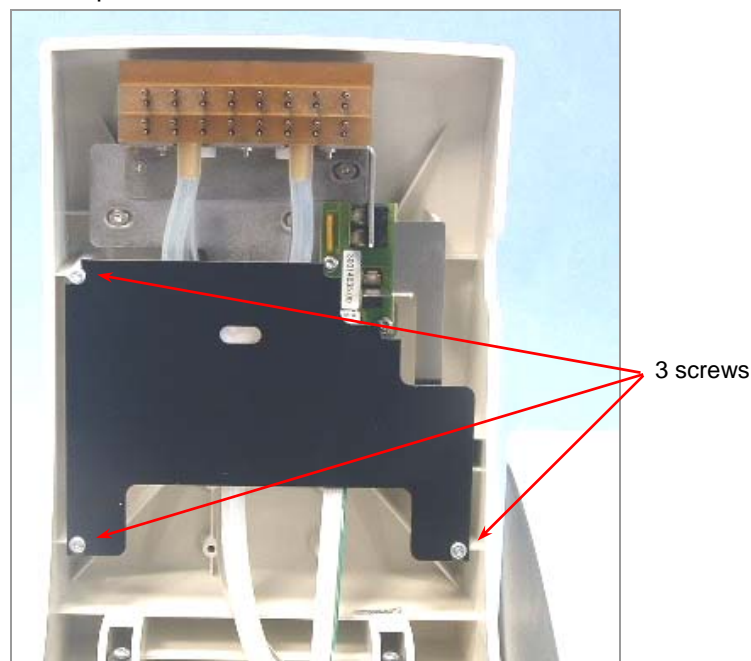

7. Lower the manifold arm and prime the instrument before starting a wash program.

## Instrument Disinfection



### WARNING

The disinfection procedure should be performed according to national, regional, and local regulations.



### WARNING

All parts of the instrument that come into contact with potentially infectious material must be treated as potentially infectious.

It is advisable to adhere to applicable safety precautions, (including the wearing of powder-free gloves, safety glasses, and protective clothing) to avoid potential infectious disease contamination when performing the disinfection procedure.

It is very important that the instrument is thoroughly disinfected before it is removed from the laboratory or any servicing is performed on it.

Before the instrument is returned to the service center for service or repair, it must be disinfected and a disinfection certificate completed by the operating authority. If a disinfection certificate is not supplied, the instrument may not be accepted by the service center or it may be held by the customs authorities.

## Disinfection Solutions

Use the following disinfection solutions for the disinfection procedure:

- Decon 90 (Decon Laboratories Limited)
- Decon Neutracon (Decon Laboratories Limited)
- Microcide SQ (Global Biotechnologies)
- Ethanol



### WARNING

**Risk of fire and explosion!**

Ethanol is flammable and when improperly handled can lead to explosions. Proper laboratory safety precautions must be observed.

### Disinfection Procedure

The instrument should be disinfected using one of the solutions mentioned previously.



#### **WARNING**

**Risk of fire and explosion!**

**Prior to cleaning the outer surface of the instrument and the display, switch off the instrument and disconnect it from the main power supply!**



#### **Caution**

**Before starting the disinfection procedure use a rinse procedure (Rinse Day) with distilled or deionized water (lab quality) to flush the system.**



#### **WARNING**

**The disinfection procedure should be performed in a well-ventilated room by authorized trained personnel wearing disposable powder-free gloves, protective glasses and protective clothing.**

Please note that the disinfectant can influence the performance of your instrument, if it comes into contact with the electronics! Wear protective powder-free gloves, protective glasses, and protective clothing.

The following procedure should be used to disinfect the instrument:

1. Prepare an autoclave bag for all disposables used during the disinfection procedure, label it with autoclave tape and disinfect the material using the autoclave, or follow the local regulations for decontamination of this material.
2. Prime the liquid system with disinfectant. Perform the Rinse Night procedure with disinfectant solution and stop the procedure after five hours.
3. Switch off the instrument and disconnect the instrument from the power supply.
4. Disconnect the instrument from any accessories that are used, for example: Liquid Level Detection System, computer, etc. Accessories that should be shipped together with the instrument have to be included in the disinfection procedure.
5. Carefully spray the disinfectant solution on all outer instrument surfaces, or wipe with a disposable soft tissue paper towel soaked in the disinfectant.
6. After a minimum contact time of 10 minutes, repeat step 5 of this procedure.
7. Wipe the outer surfaces of the instrument dry.
8. Pack the instrument and its accessories.
9. Wash your hands with a mild detergent, and then disinfect them.



- If returning the wash station to Bio-Rad for servicing, contact your local Bio-Rad service office to obtain the appropriate documents. Failure to do so may result in significant delays.

## Disposal of Instrument

This chapter gives instructions on how to lawfully dispose of waste material accumulating in connection with the instrument.



### Caution

Observe all federal, state, and local environmental regulations.



### ATTENTION

European Directive 2002/96/EC on waste electrical and electronic equipment (WEEE) has disposal rules which attempt to avoid negative environmental impacts associated with the treatment of electrical and electronic equipment waste.

Do not treat electrical and electronic equipment as unsorted municipal waste.

Collect waste from electrical and electronic equipment separately.

## Disposal of Operating Material



### WARNING

Chemical and Biological hazards can be associated with the waste material (Microplate) of processes run on the Instrument.

Treat the used Microplate, Waste Bottle, Prime tray on the Plate carrier, disposables and all substances used, in accordance with good laboratory practice guidelines.

Inquire about appropriate collecting points and approved methods of disposal in your country, state, or region.

## Disposal of the Instrument

Please contact your local service representative before disposing of the instrument.



### Caution

Always disinfect the instrument before disposal.

Pollution degree

2 (IEC/EN 61010-1)

Method of Disposal

Contaminated Waste



### **WARNING**

Depending on the applications, parts of the Instrument may have been in contact with biohazardous material.

- Make sure to treat this material according to the applicable safety standards and regulations.
- Always clean and disinfect all parts before disposal.

Dispose of packaging material according to local regulations.

# Troubleshooting and Error Messages

## *Errors Without Messages*

The following errors will not yield an error message from the instrument's firmware:

Error Description	Possible Causes	See
Display and LED dark	Fuse is defective.	Contact your local Service Representative
No or incorrect dispensing	Dispensing needles blocked.	Cleaning the Manifold on page 62
No or incorrect aspirating	Aspirating needles blocked.	Cleaning the Manifold on page 62

## *Error Messages*

### *Plate Error*

If the plate sensor does not recognize the plate or no plate is inserted on the plate carrier, the following message is displayed:

NO PLATE OK
----------------

Press **OK** and insert the plate correctly on the plate carrier

### *Program Too Big Error*

If the program has been defined with more than 60 process steps (each cycle is worth 2 steps), the following message is displayed:

PROGR: TOO BIG OK
----------------------

Press **OK** and define a program with less than 60 process steps.

### *Transport Error*

If the instrument cannot move the plate carrier, the following message is displayed:

INIT ERROR OK
------------------

Press **OK** to remove the error message and the instrument returns to the standby mode.

Check that the plate carrier is correctly inserted and that the plate carrier system is clear.

### **Manifold Arm Error**

If the manifold arm cannot be lowered correctly due to obstruction of its normal movement, the following message is displayed:

MANIFOLD HEAD UP EXIT
--------------------------

Press **EXIT** to remove the error message and to return to the standby mode.

Check that the microplate is correctly inserted into the plate carrier.

Check that the VACUUM FILTR setting is set appropriately for the plate carrier being used, as described on page 25.

Check that the manifold arm is not blocked.

Check if the needles are catching on the side of the microplate; use the Settings menu to adjust the positions for that particular type of microplate.

### **Sensor Defect Error**

The following message error is displayed when the dispensing pump or the dispensing sensor is defective.

SENSOR DEFECT OK
---------------------

Press **OK** to remove the error message and to return to the standby mode.

Make sure that drip mode has not been selected using distilled water. Change the program parameters.

If the program parameters are correct and the error continues, call the service technician.

### **RS485 Error**

This error is displayed if vacuum filtration is activated in the instrument settings on a Bio-Plex Pro instrument. (A different message will be displayed on a Bio-Plex Pro II.)

RS485 TIME OUT OK
----------------------

Press **OK** to remove the error message and to return to the standby mode.

Disable vacuum setting as outlined on page 24.



#### **Caution**

**The instrument cannot end the wash procedure. Please end the test manually or dispose of the microplate!**

## PC (Process Control) System Error

If the Process Control board does not respond, the following error message is displayed:

Examples of Error Messages: PC SYS ERROR  
PC FUNCT. ERR  
PC ASP ERROR

Process Control functionality has been inadvertently activated for your system. Your system is not equipped for process control, so it must be deactivated. The following directions describe how to check and disable a PC setting.

Remember to exit to the Primary Menu before performing this procedure. (Press Exit until the word EXIT disappears.)

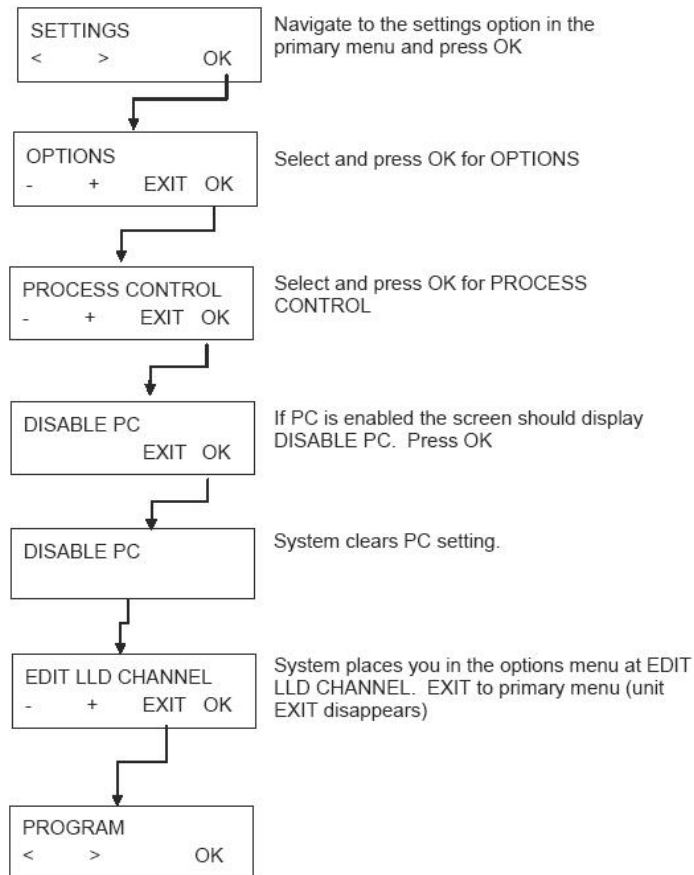

**Turn instrument off and back on for change to take effect.** If the error continues, call the service technician.

## No Aspiration at Vacuum Filtration Error

The following error message appears on the display:

NO ASP AT VACFIL  
OK

Press **OK** to remove the error message and to return to the standby menu.

## LLD Errors

Examples:

LLD ERROR L

LLD ERROR W

LLD has been inadvertently activated for one channel in your system. This is an advanced function for which your system is not equipped. All channels should be deactivated for LLD. The following directions describe how to check and clear all channels of an LLD setting.

Remember to exit to the Primary Menu before performing this function. (Press EXIT until the word EXIT disappears.) If this does not solve the problem, please contact technical support.

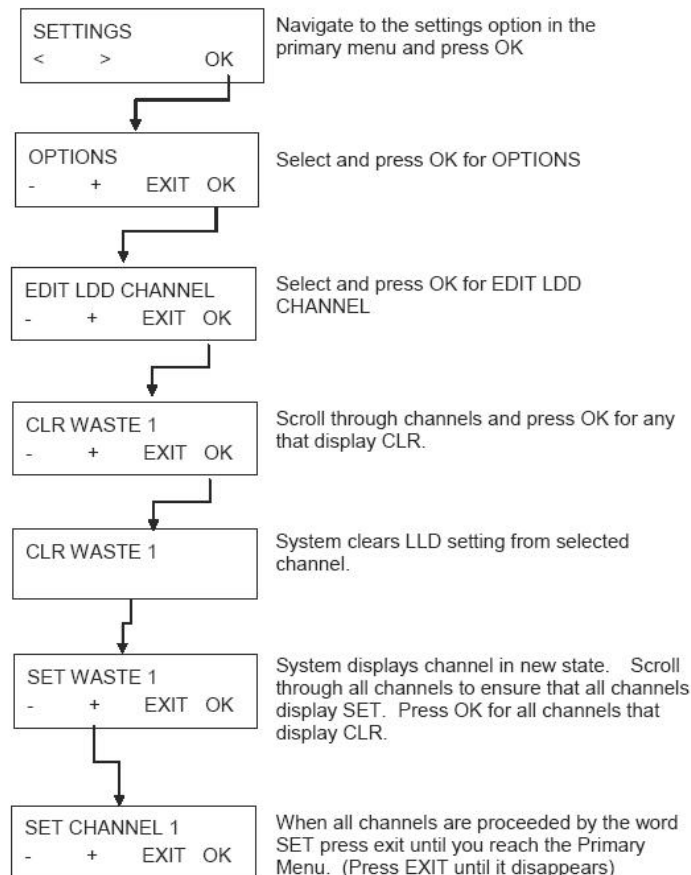

Make sure all channels are preceded by the word Set  
WASTE  
CHANNEL 1  
CHANNEL 2

# Declaration of Conformity

TECAN AUSTRIA GMBH, Untersbergstrasse 1a, A-5082 Grödig / Salzburg, Austria  
T +43 62 46 09 33, F +43 62 46 72 770, office.austria@tecan.com, www.tecan.com



## Declaration of Conformity

We, TECAN Austria GmbH herewith declare that the product identified as:

**Product Type:** Microplate Wash Station  
**Model Designation:** Bio-Plex Pro<sup>™</sup>, Bio-Plex Pro<sup>™</sup> II  
**Article Number(s):** 30034376, 30034377

**Placed into market by:** Bio-Rad Laboratories  
6000 Alfred Nobel Drive  
Hercules, CA 94547

**Produced by:** Tecan Austria  
Untersbergstr.1A  
5082 Grödig  
Austria

is in conformity with the provisions of the following EC Directive(s) when installed in accordance with the installation instructions contained in the product documentation:

**2006/95/EC – Low Voltage Directive**  
**2004/108/EC – EMC Directive**

and that the standards referenced below were taken in consideration:

EN 61010-1:2001	Safety requirements for electrical equipment for measurement, control, and laboratory use - Part 1: General requirements
EN 61010-2-081:2002 + A1:2003	Safety requirements for electrical equipment for measurement, control and laboratory use – Part 2-081: Particular requirements for automatic and semi-automatic laboratory equipment for analysis and other purposes
EN 61326:1997 + A1:1998 + A2:2001 + A3:2003	Electrical Equipment for Measurement, Control, and Laboratory Use - EMC Requirements

Year of CE-marking: 08

Place, Date: Grödig, 2008-03-03

Legally binding signature:

Name:  Harald Negele

Function: Head of Finance and Administration

 Siegfried Sasshofer

Head of Sales and Marketing

---

# Index

Aspiration.....	50	Secondary .....	20
of Prime Tray .....	63	Settings .....	61
Bubble Sensor .....	63	Microplates	
Checklists		Installation .....	19
Unpacking.....	40	Recommended .....	12
Cleaning		On/off switch.....	19, 42
Cover and Display .....	65	Plate Carriers .....	17
Liquid System .....	65	Images.....	17
Manifold .....	66	Removal, Replacement .....	17
Waste Bottles.....	66	Selecting.....	17
Configuration		Power Requirements .....	40
and plate carriers .....	33	<b>Precautions</b>	
Options .....	11	When using vacuum plate carrier .....	24
Custom Wash Programs.....	48, 53	Prime Tray	
Diagram		Emptying .....	63
Back Panel .....	39	Priming	
Installation of Bio-Plex Pro.....	14	Failures.....	21
Installation of Bio-Plex Pro II.....	15	How to .....	21
Key Pad .....	20	When to .....	20
Liquid System .....	36	Rinsing .....	25
Dimensions		Leaving instrument off .....	26
Bio-Plex Pro.....	37	Leaving instrument on .....	26
Bio-Plex Pro II.....	38	Rinse Day.....	25
Disinfection .....	71	Rinse Night.....	26
Procedure .....	72	Serial number .....	39
Solutions.....	71	Spills.....	67
Keypad .....	20	<b>Tubing Bracket</b> .....	16
Maintenance .....	28	Unpacking .....	40
Menus		Vacuum Filtration	
and the keypad .....	20	Disable .....	18
Navigating.....	20	Enable .....	18
Options .....	62	Wash Programs	
Overview.....	20	Quick Guide.....	23
Primary .....	20	Running.....	22
Procedures .....	63	Selecting.....	23
Program .....	53	Working Area Requirements .....	40
Quick Guide .....	24		







**Bio-Rad  
Laboratories, Inc.**

Life Science  
Group

Web site [www.bio-rad.com](http://www.bio-rad.com) **USA** 800 4BIORAD **Australia** 61 02 9914 2800 **Austria** 01 877 89 01 **Belgium** 09 385 55 11 **Brazil** 55 21 3237 9400  
**Canada** 905 364 3435 **China** 86 21 6426 0808 **Czech Republic** 420 241 430 532 **Denmark** 44 52 10 00 **Finland** 09 804 22 00 **France** 01 47 95 69 65  
**Germany** 089 318 84 0 **Greece** 30 210 777 4396 **Hong Kong** 852 2789 3300 **Hungary** 36 1 455 8800 **India** 91 124 4029300 **Israel** 03 963 6050  
**Italy** 39 02 216091 **Japan** 03 6361 7000 **Korea** 82 2 3473 4460 **Mexico** 52 555 488 7670 **The Netherlands** 0318 540666 **New Zealand** 0508 805 500  
**Norway** 23 38 41 30 **Poland** 48 22 331 99 99 **Portugal** 351 21 472 7700 **Russia** 7 495 721 14 04 **Singapore** 65 6415 3188 **South Africa** 27 861 246 723  
**Spain** 34 91 590 5200 **Sweden** 08 555 12700 **Switzerland** 061 717 95 55 **Taiwan** 886 2 2578 7189 **United Kingdom** 020 8328 2000