

# 2KW USER'S MANUAL

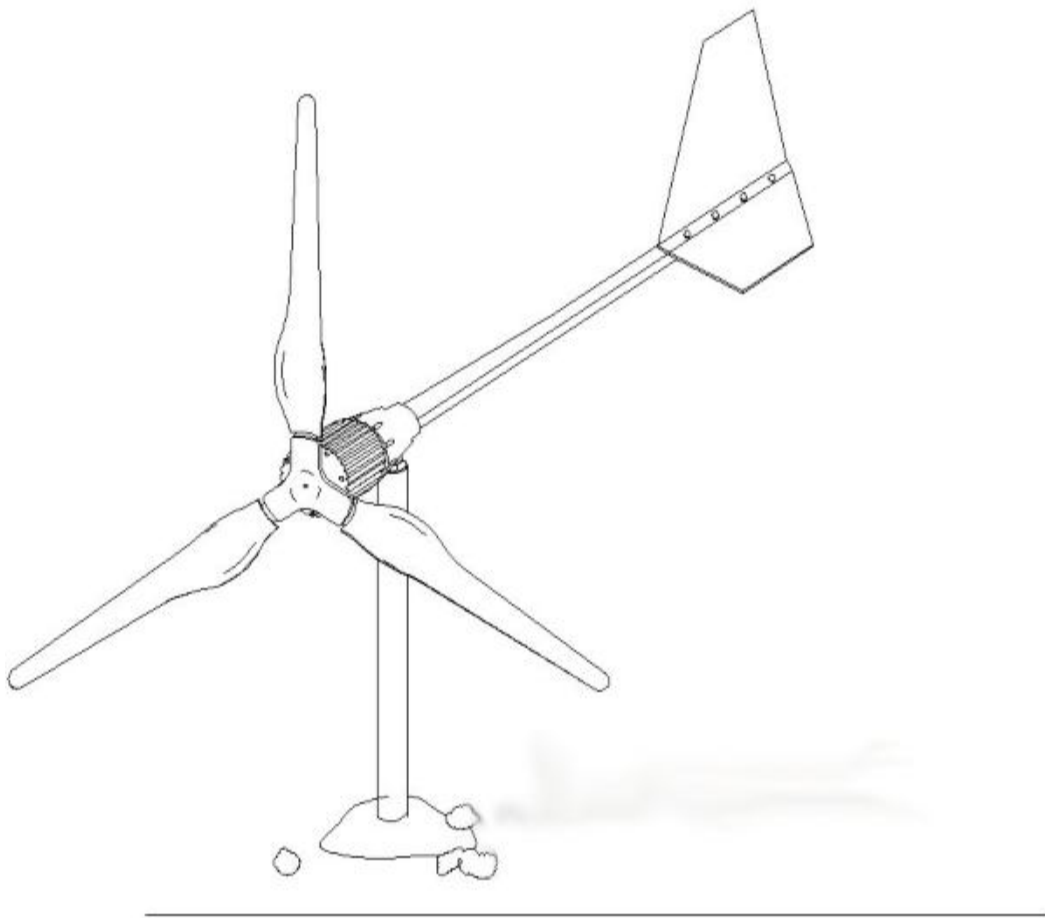

## **Distinguished Users:**

We are very glad that you choose our company's products and feel sure that you will find the convenience that our products bring to you and the joy of promoting the policy of "low carbon and environmental protection".

Please do not forget to read the "User Installation Manual" before installing of the products.

## **Catalogue**

<b>Part1. Safety Warning and Attentions -----</b>	<b>3</b>
<b>Part2. Product Description-----</b>	<b>6</b>
<b>Part3. Product Structure and Features-----</b>	<b>7</b>
<b>Part4. The Wind Turbine Installation Steps-----</b>	<b>7</b>
<b>4.1. Tower base, anchors making and installation</b>	
<b>4.2. Assembling of wind turbine and tower</b>	
<b>4.3. Battery installation and connection</b>	
<b>4.4. Connection of controller and inverter</b>	
<b>Part 5. Maintenance and Attentions-----</b>	<b>11</b>
<b>Part 6. Packing List-----</b>	<b>12</b>
<b>Part 7. Quality Guarantee-----</b>	<b>13</b>
<b>Part 8. Maintenance Records -Table-----</b>	<b>14</b>

## **Part1. Safety Warning and Attentions :**



For correct installation and use of this equipment, please read carefully the safety warning and attention and strictly follow the instructions.

### **Basic requirements:**

- Do not disassemble the equipment by you. Please contact the specified maintenance department when the equipment is out of order.
- Without authority, no company or individual are allowed to change the equipment structure, safety and performance design.
- please obey local laws and regulations when using this product

### **Assembling requirements:**

1. Before the assembly of the wind generator or in the process of maintenance, please be sure to read the users manual first.
2. Please don't install the wind turbines in rainy days or when the wind scale is at Level 3 or above.
3. After opening the package, it is advised to short circuit the three leads of the wind turbines (the exposed copper parts should be screwed together).
4. Before the installation of the wind turbine, lightning grounding must be prepared. You can arrange the facilities according to national standards, or you may arrange them according to the local environment and soil condition. Table 1 is for reference.
5. When assembling the Wind turbine, all the parts should be fastened with fasteners specified in table2.

**Table 1**

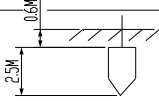
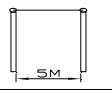
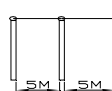
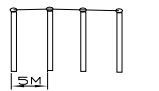
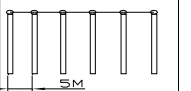
型式	简图	材料尺寸 (MM) 及用量 (M)				土壤电阻率 欧·米		
		圆钢 Ø20	钢管 Ø50	角钢 50*50*5	扁钢 40*4	100	250	500
						工频接地电阻 欧		
单根		2.5	2.5	2.5		30.2 37.2 32.4	75.4 92.9 81.0	151 186 162
2根			5	5	2.5 2.5	10.0 10.5	25.1 26.2	50.2 52.5
3根			7.5	7.5		6.65 6.92	16.6 17.3	33.2 34.6
4根			10	10	7.5 7.5	5.08 5.29	12.7 13.2	25.4 26.5
6根			15	15	25 25	3.58 3.73	8.95 9.32	17.9 18.6

**Table2**

Serial#	Fasteners	spec	qty	tightening torque (N*M)	remarks	Executive standard
1	Bolts for blades	M10*50	12	≥41		
2	Lock nut on shaft	M24	1	≥156		
3	Tail bolts	M8*45	4	≥19		
4	Tail nut	M8	4	≥19		
5	Flange nuts	M16*60	4	≥116		
6	Tail board nut	M16*170	1	≥116		

6. Before hoisting the wind turbines, the end (which should be connected with controller) of the tower lead should be cut away the insulating layer for 10mm or so. Then screw the three exposed leads (short circuit) together.

7. Before the connection between the wind turbine flange and the tower flange, please connect the three leads of the wind turbine to the three leads of the tower accordingly. When using the hinge method, every pair of wires should be no less than 30mm in length and be wrapped with Acetate cloth tape for three layers, then sheathed with spun glass paint tube. With this method, connect the three pairs of wires (attention: the joint of the wires can't bear the weight of the tower leads directly, so wires 100mm downward from the joint should be wrapped with adhesive tape and then stuffed into the steel pipe. After that, wind turbine flange and tower flange can be connected.

8. During the installation, it is prohibited to revolve the rotor blades roughly (the ends of wind turbine leads or the tower leads are short-circuited at this moment). Only after all the installation and the examination is finished and the security of the erection crew is guaranteed, it is allowed to dismantle short circuited leads and then connect with controller and battery before running.

**Attention:**

**Battery should be connected with controller before wind turbine connected with controller**

**If above stated instruction are not followed when assembling and installing the wind turbines, we are sorry that any problem or failure resulted are not to be covered by warranty.**

## Part2. Product Description

1. Low start up speed; high wind energy utilization; beautiful appearance; low vibration
2. Human friendly design, easy installation, maintenance and repair.
3. Precise injection molding blades together with the optimized design of aerodynamic contour and structure, the blades have such advantages: high utilization of wind energy which contributes to the annual energy output.
- 4.the generators, adopting patented permanent magnet rotor alternator, with a special kind of stator design, efficiently decrease resistance torque. Meanwhile, it makes the wind turbines match the generators quite well and increase its reliability.

Model	NE-2000
Rated power (W)	2000
Rated voltage (V)	48/96
Wheel diameter (m)	3.2
Start up wind speed (m/s)	3
Rated wind speed (m/s)	11
Survival wind speed (m/s)	45
TOP NG (kg)	<b>43</b>
Body material	Casting aluminum
Blades material	glass fiber reinforced plastics
generator	Three phase ac permanent magnet generator
Blades number	3
protection	Electronic magnet/mechanic furling
lubrication	Lubrication grease
Working temperature	-40°C-80°C
Suggest Tower height (m)	6
Suggest Tower type	Guyed tower

## **Part 3 Product Structure and Features**

**The wind turbine consist of wind wheel, generator set( generator and swivel),tail, guyed tower, controller inverter,maintain-ance free lead acid battery.**

1. Wind wheel: 3 blades wheel, Laminar flow type, high lift-drag ratio, good performance. Nylon fiber blades using precision injection, strong toughness and perfect dynamic nature.
2. Generator and swivel are designed in a complete body, a close compact structure which enhances toughness, reduce weight of the generator set, and thus make it rotate more easily and safely.
3. Tail, using molding, spined with swivel shaft ,tail furls to protect wind turbine in strong wind.
4. Controller converts ac current produced by wind turbine to be dc current to charge battery
5. Battery, lead acid maintenance free battery

## **Part 4. The Wind Turbine Installation Steps**

Wind turbine should be installed on a pole as high as possible, and be clear of obstacles (refer to pic 1-1) to capture big wind turbine. The soil condition should be taken into consideration; those conditions are not recommended, sand land, ruggy places or places vulnerable to climate. The distance from the wind generator to the battery is suggested to be as short as possible to save cables and lessen power losses over transmission, if long distance can not be avoided, please choose thick standard cables.

### **4.1. Tower base, anchors making and installation**

1. Layout of tower base and anchor (pic 1-2). Attention: the connection line from anchor A to B should be parallel to the connection line of the two pin holes on the base, which is to ensure the tension of lasso balanced and adjustable; and keep the anchors and tower base of same height, otherwise the tension of lasso might be too loose or too tight, tower might be bent or down.

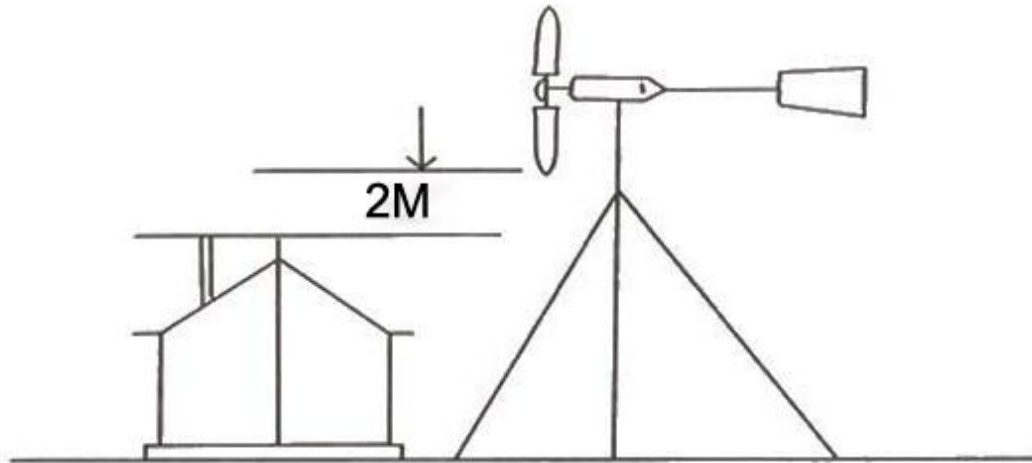

Pic 1-1

2. Dig holes for cement block following the layout, the center holes edge length is suggested to be 0.7m, depth 0.8m, and holes for the anchors edge length is suggested to be 0.6m, depth 0.8m.
3. Pour cement block, and mix it with some steel bar and 4 anchor bolts, please make sure the base hole align with the anchor bolts
4. The 4 ring shape anchor installed toward tower base, adjust the distance of 4 anchor from the center of tower base to make even distance
5. Fix the tower base on the concrete block with bolts



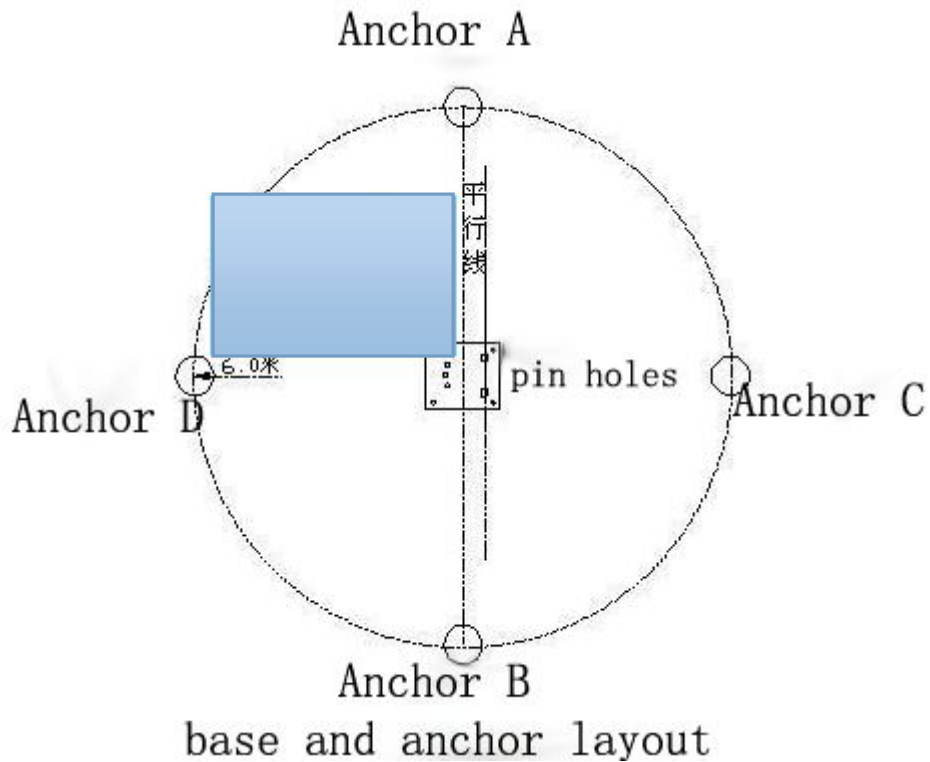

#### 4.2. Assembling of wind turbine and tower

1. First put the bottom section of tower into the tower base, then thrust the pin shafts into the spin holes on the tower base
2. Connect the middle and upper section of tower orderly, and then place it onto a wood stand
3. Pull the cables of wind generator through the tower pipe, and led out from the hole on the bottom section of tower.
4. Fasten the tower flange and the wind turbine flange with bolts; please make sure the wind generator is placed in a proper position to make easy blades installation.
5. Blades installation, put the windward side upward (pic 2-1), screw the bolt (not to screw it tight), adjust the blades ends distance to be balanced, then screw tight bolts, make sure  $L1=L2=L3$ , allowance within 5mm (please refer to pic 2-2)

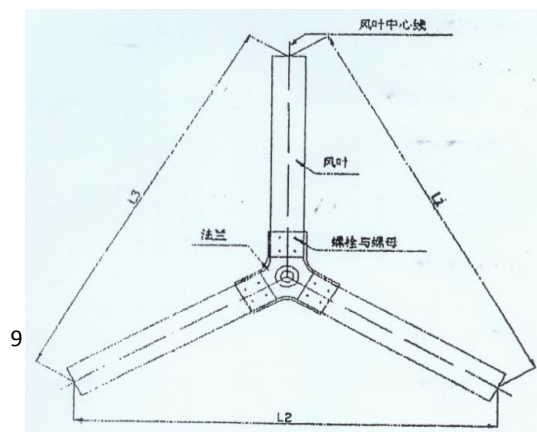

**Pic 2-1**

**Pic 2-2**

6. Install the blades flange onto the generator shaft, then covered with dome.
7. Tail installation, the side with buffering rightward (pic 2-3), the tail board fix on the left of tail (pic2-4) with the sharp end upward (pic2-5)
8. Pull the steel lasso through the holes on the upper tower (pic 2-6), the left and right lasso connected to the side anchors with Turnbuckle, the back lasso fixed with the back anchor with the same length as left and right lasso, please make sure the three lasso does not wrap together, the front lasso fixed with front anchor after the tower hoisted vertically.
9. Check the tension of lasso, adjust its tension by rotating the Turnbuckles to make sure tower not bent when too tight or shake when too loose.

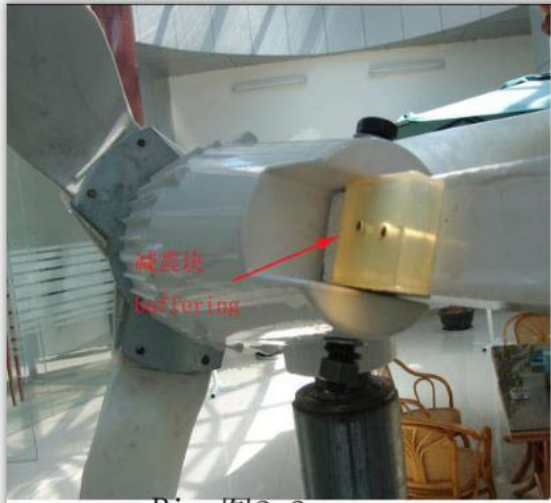

Pic 图2-3



Pic 图2-4



Pic 图2-5



Pic 图2-6

### 4.3. Battery installation and connection

1. The battery should be placed in a dry, ventilated place; a wood stand is suggested to hold batteries, controller and inverters.
2. Connect batteries in series, connect the positive electrode of the first battery to the negative electrode of the second batteries, same is to be followed with other batteries.
3. Lubricate all the terminals with grease or other anti-corrosion materials, install fuse on the positive terminals of batteries and keep the cables between controller and batteries within 3m to avoid possible electronic magnet interference.

### 4.4 Connection of controller and inverter

1. The controller should be placed in dry, well ventilated place, moisture and dust-protected, inverter shell should be kept grounded and more than 1.5 meters away from the batteries to avoid acid gas pollution.
2. The positive terminal of battery indicator on the controller should be connected with the positive electrode of last battery and negative terminal with negative electrode on the first battery

3. Connect the three wires of wind turbine correspondingly with the wind turbine terminals on the controller.
4. Please be noted that the input voltage of inverter should equate with the batteries voltage in series.
5. It is prohibited to run the wind turbine without load to avoid blades damage when high speed rotation



## Part 5. Maintenance and Attentions

1. wind turbine is generally worked in windy areas, please check it 3 months after installation, fasten bolts,nuts,check whether the tower shaking, lasso loose, if anything amiss, please solve it immediately
2. Please check wind turbine right before or after storm, if anything amiss, it is advised to lay down slowly wind turbine to do inspection or repair. If inspection needs to be done on the tower, make sure wind turbine have been short circuited and protection measures taken before and election climb up.
3. The free maintenance batteries should be kept externally clear.
4. Do not disassemble the equipment by yourself. Please contact sales department when the equipment is out of order.

## Part6. Packing list

Serial #	Item	Quantity	Remarks
1	generator	1	
2	Main shaft nut (M24)	1	
3	Flat washer/elastic washer	1	
4	hub	1	
5	blades	3	
6	Blades bolt (M10*50)	12	Refer to pic 2-1
7	dome	1	
8	Blades bolt (M6*55)	1	
9	tail	1	
10	Tail board	1	
11	Tail spin	1	
12	tail nuts and bolts	1	
13	(M16*60) flange bolts	4	optional
14	(M16*60) flange nuts	4	optional
15	controller inverters	1	optional
16	tower	1	optional
17	battery	1	optional
18	installation guide	1	

## Part7. Quality Guarantee

1.The company guarantees customers that generator is of excellent quality,function is good, the body is complete,rigorously checked before delivery,

2.The wind turbine should be maintained by professional person regularly, the problems resulted from irregular maintain-ance or without maintain-ance are not to be covered by the warranty

2,We provide 2 year's warranty for wind generator since the date of sale, damages occurred in the following situation:dismantle optionally by yourself or seriously violate operation (not according to instructions use) are not covered by warranty, in such case cost to be charged when repair at our designated shop.

3. We offer maintain-ance and repair then products warranty expires at cost.

4, The documents are as a product warranty certificate, please keep it properly.

### User information table:

Sales company:	Purchase company:
Purchase time:	Contact person:
SBBH:	Contact:
Model:	Zip code:

### Maintenance records:

Date	Maintenance species	Summary	SMT rework

## Part 8. Maintenance Records-table

maintenance	Time after installation	Items	SMT rework	Date
First time	3 months	<p>Check blades and main shaft bolt, wind generator and tower, see if loose or any damage, check the tail spin and connectors ,see if any friction damages, check and see if anything amiss on the wind generator and tower, accessories</p>		
2 <sup>nd</sup> time	6months			
3 <sup>rd</sup> time	1 year			
4 <sup>th</sup> time	2 year			
5 <sup>th</sup> time	3 year			
6 <sup>th</sup> time	3 year and 6 months			
7 <sup>th</sup> time	4 year			
8 <sup>th</sup> time	4 year and 6 months			
9 <sup>th</sup> time	5 year			
10th time	5 year and 6 months			
11th time	6 year			
12th time	6 year and 6 months			
13th time	7 year			

14th time	7 year and 6 months			
15th time	8 year			
16th time	8 year and 6 month			
17th time	9 year			
18th time	9 year and 6 months			
19th time	10 year			

A whole complete inspection and repair should be made, and records remade again.